



US 20040142654A1

(19) **United States**

(12) **Patent Application Publication**
Stammer et al.

(10) **Pub. No.: US 2004/0142654 A1**

(43) **Pub. Date: Jul. 22, 2004**

(54) **ACOUSTICAL SMOKE VENT**

Publication Classification

(76) Inventors: **Scott D. Stammer**, Minneapolis, MN (US); **Michael J. Carroll**, St. Paul, MN (US)

(51) **Int. Cl.7** **F24F 7/00**

(52) **U.S. Cl.** **454/357**

Correspondence Address:

PATTERSON, THUENTE, SKAAR & CHRISTENSEN, P.A.
4800 IDS CENTER
80 SOUTH 8TH STREET
MINNEAPOLIS, MN 55402-2100 (US)

(57) **ABSTRACT**

A single layer sound insulated door assembly, and automatically releasing latch to open the door assembly in response to predetermined indicators of fire in the structure and a labyrinthine seal mechanism which limits sound transmission through the door assembly. An acoustical smoke vent is sound insulated and the doors are sealed to the curb by means of a unique labyrinthine gasket assembly effective at limiting sound transmission through the vent. The acoustical smoke vent of the present invention achieves a sound transmission class of STC 45 or better without the need for double layer door assemblies.

(21) Appl. No.: **10/755,022**

(22) Filed: **Jan. 8, 2004**

Related U.S. Application Data

(60) Provisional application No. 60/439,044, filed on Jan. 8, 2003.

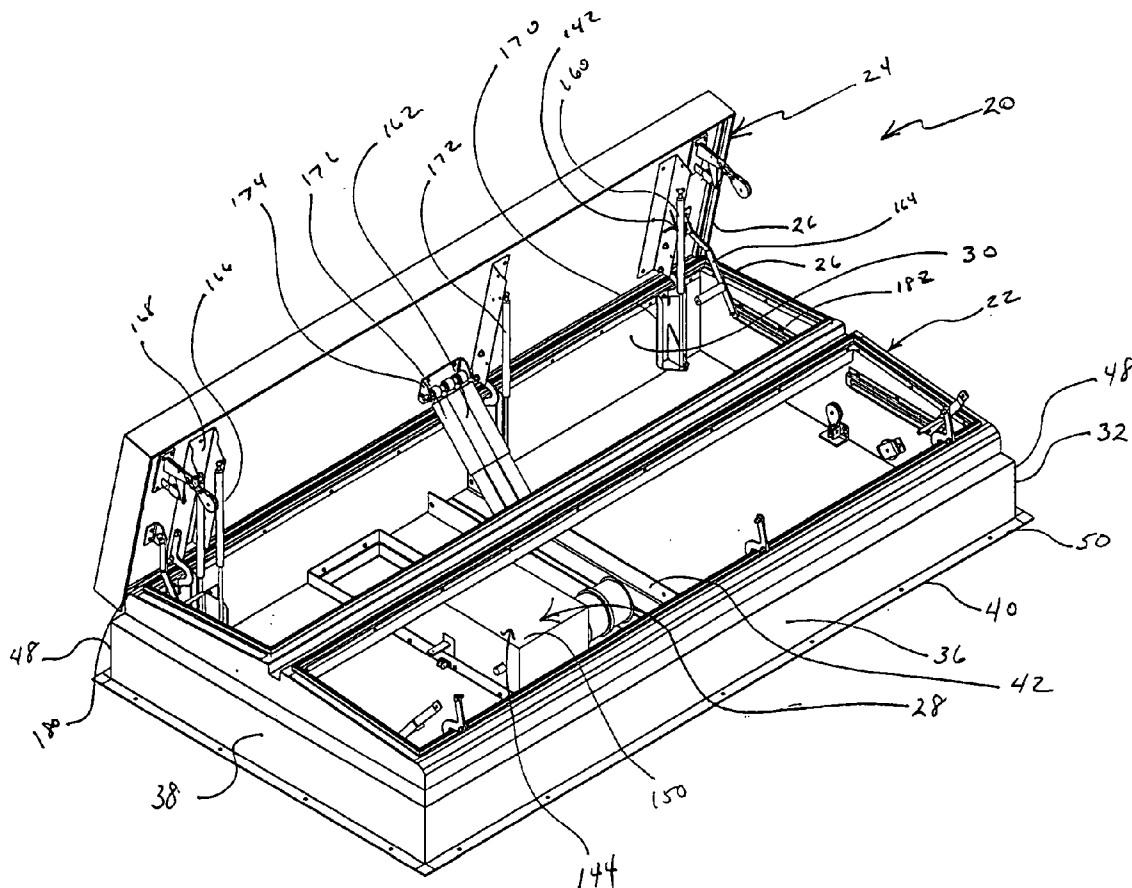

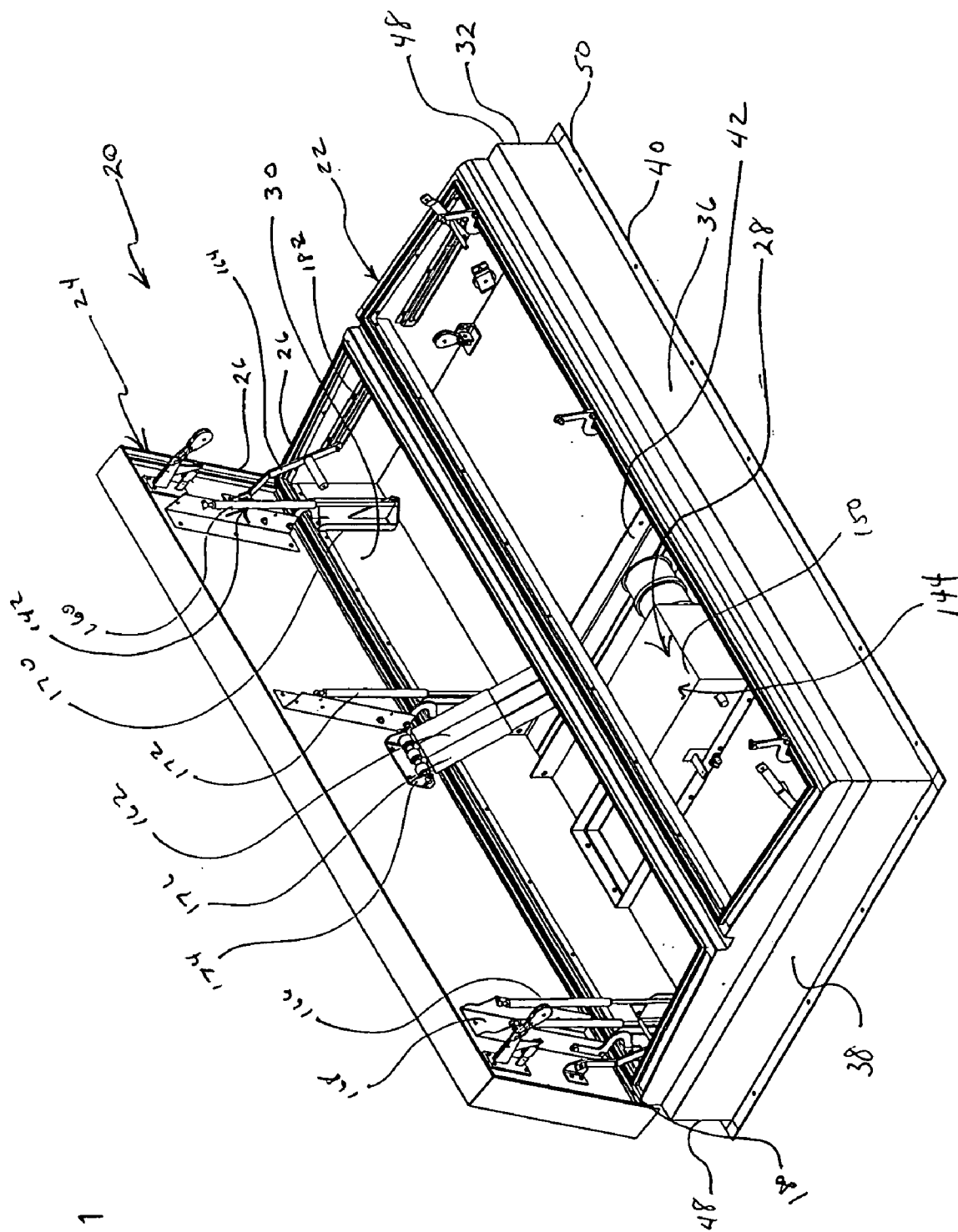

FIG. 1

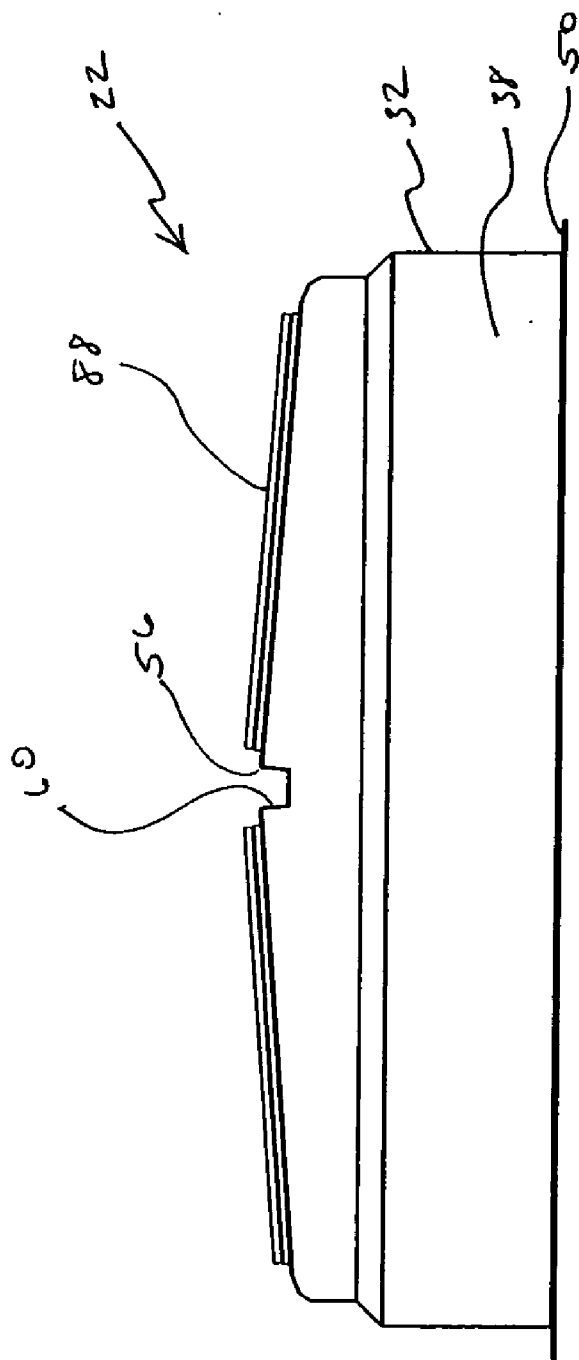
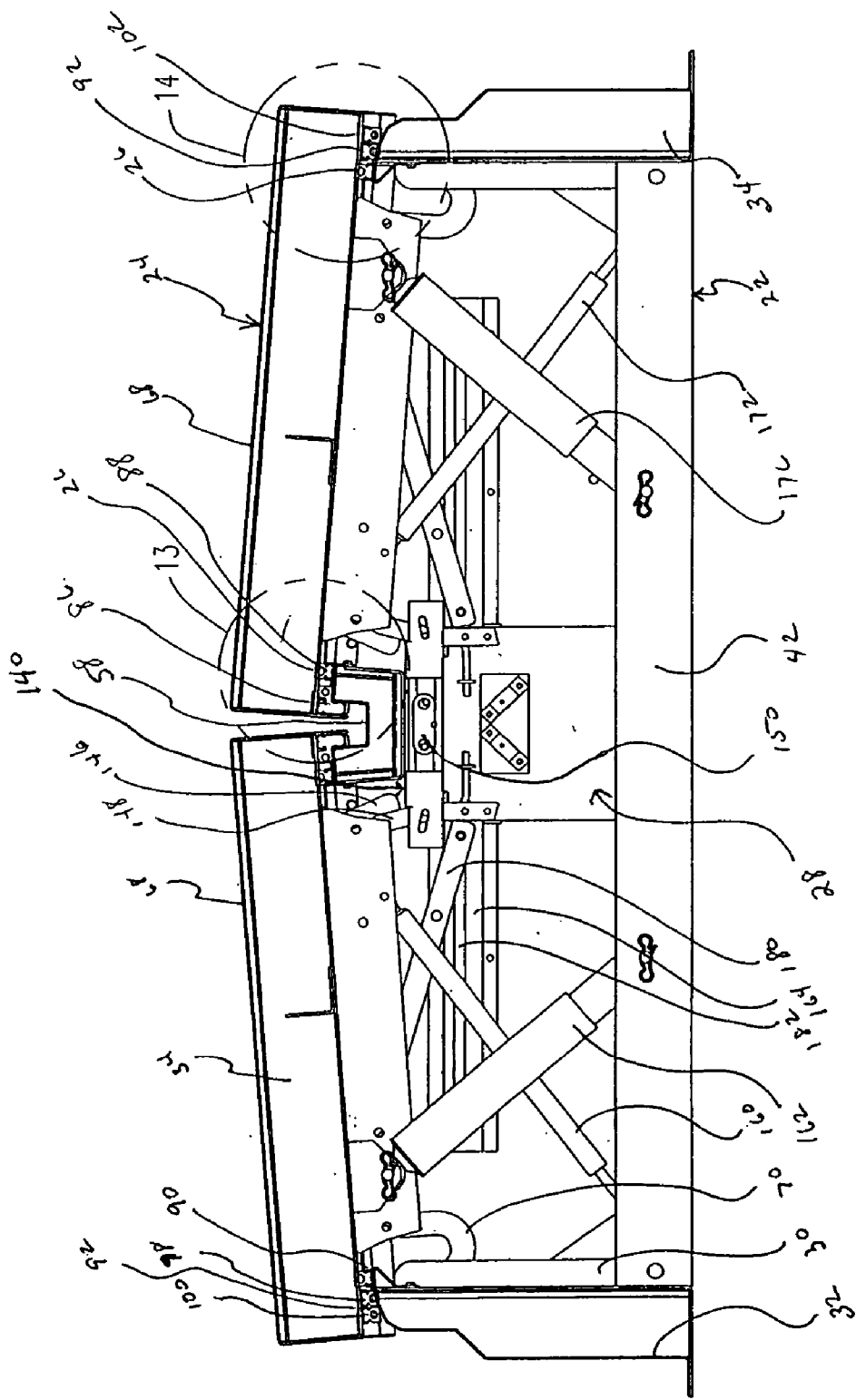

FIG. 2

FIG. 3



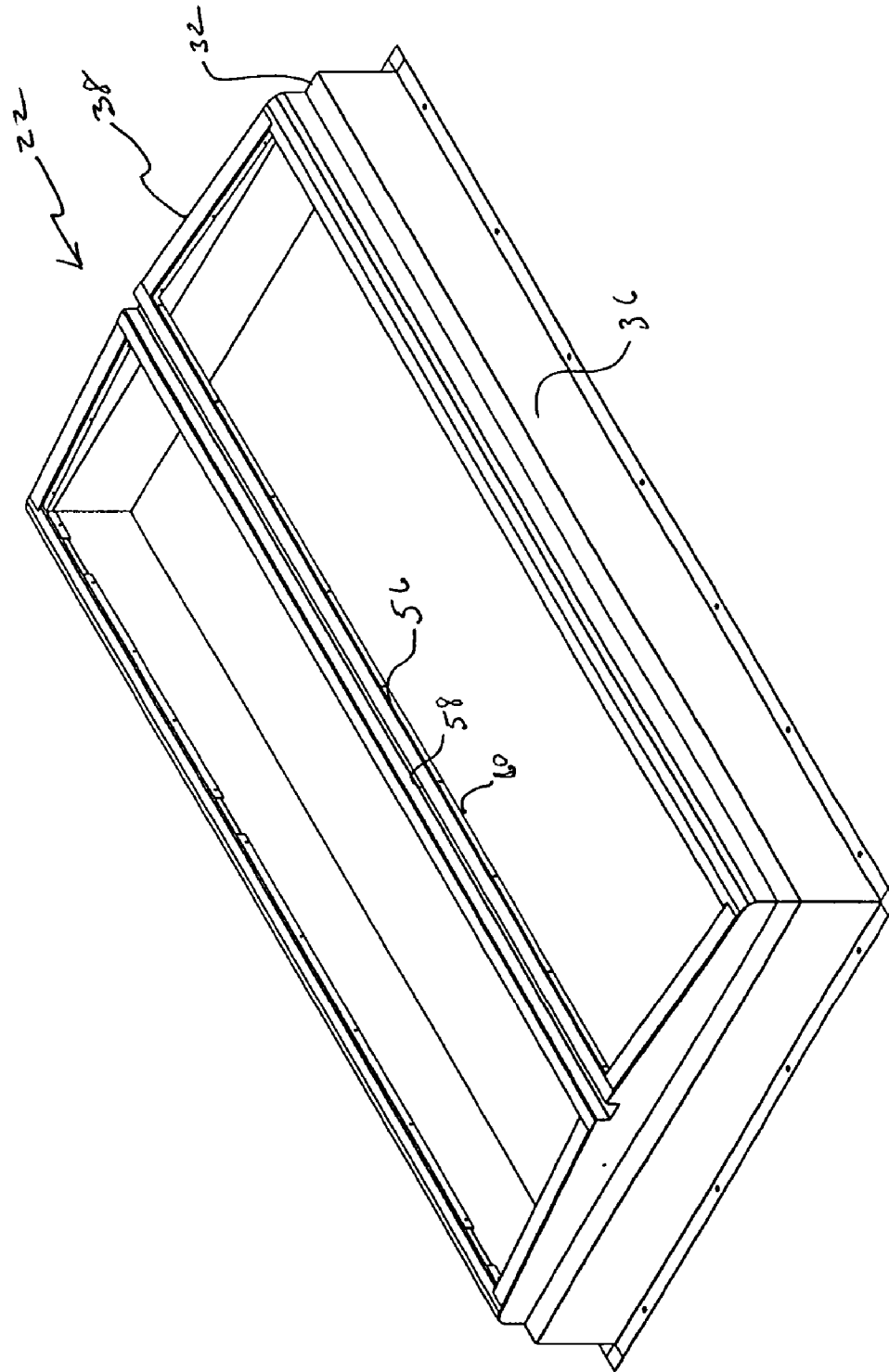
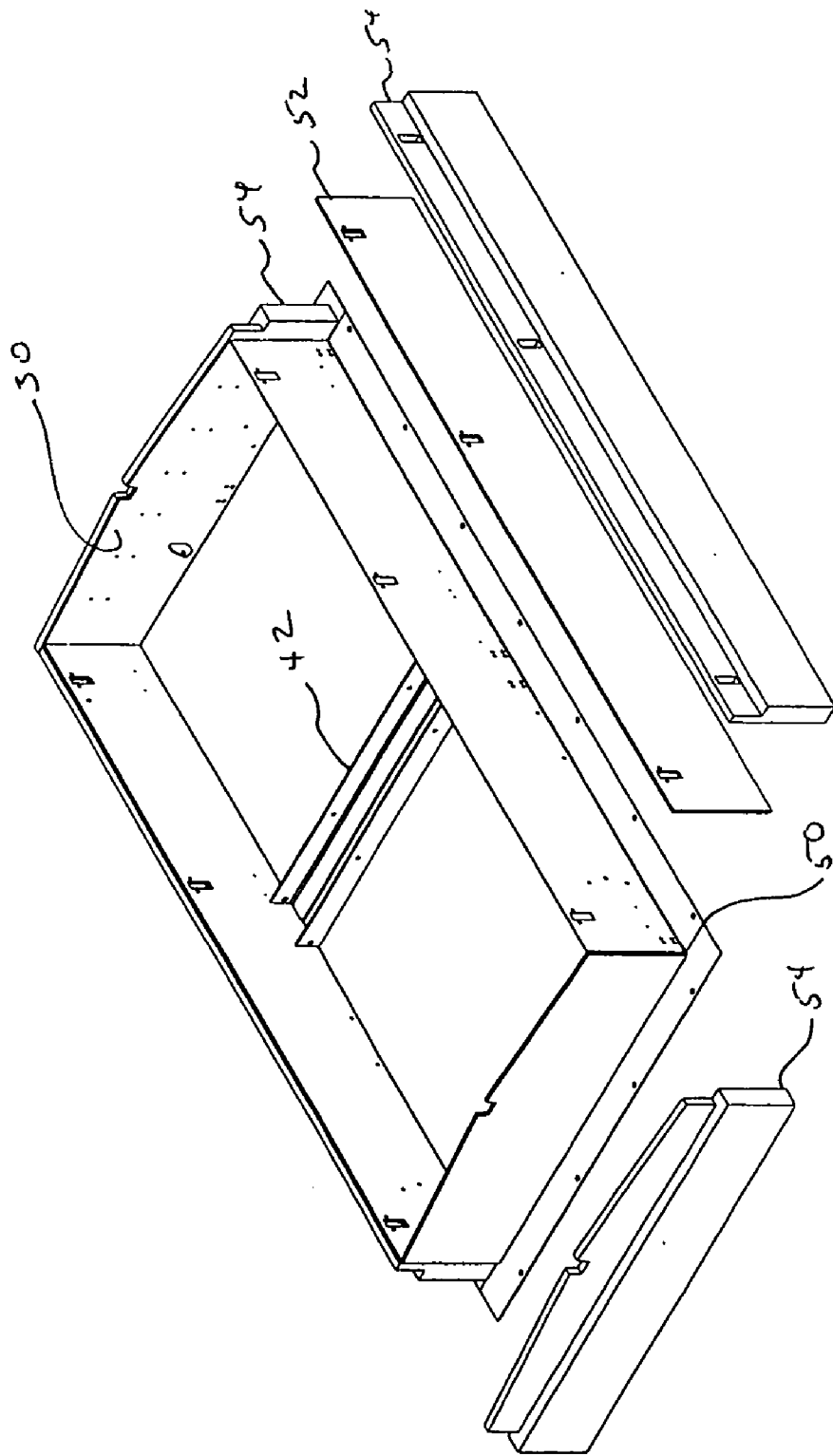

FIG. 4

FIG. 5



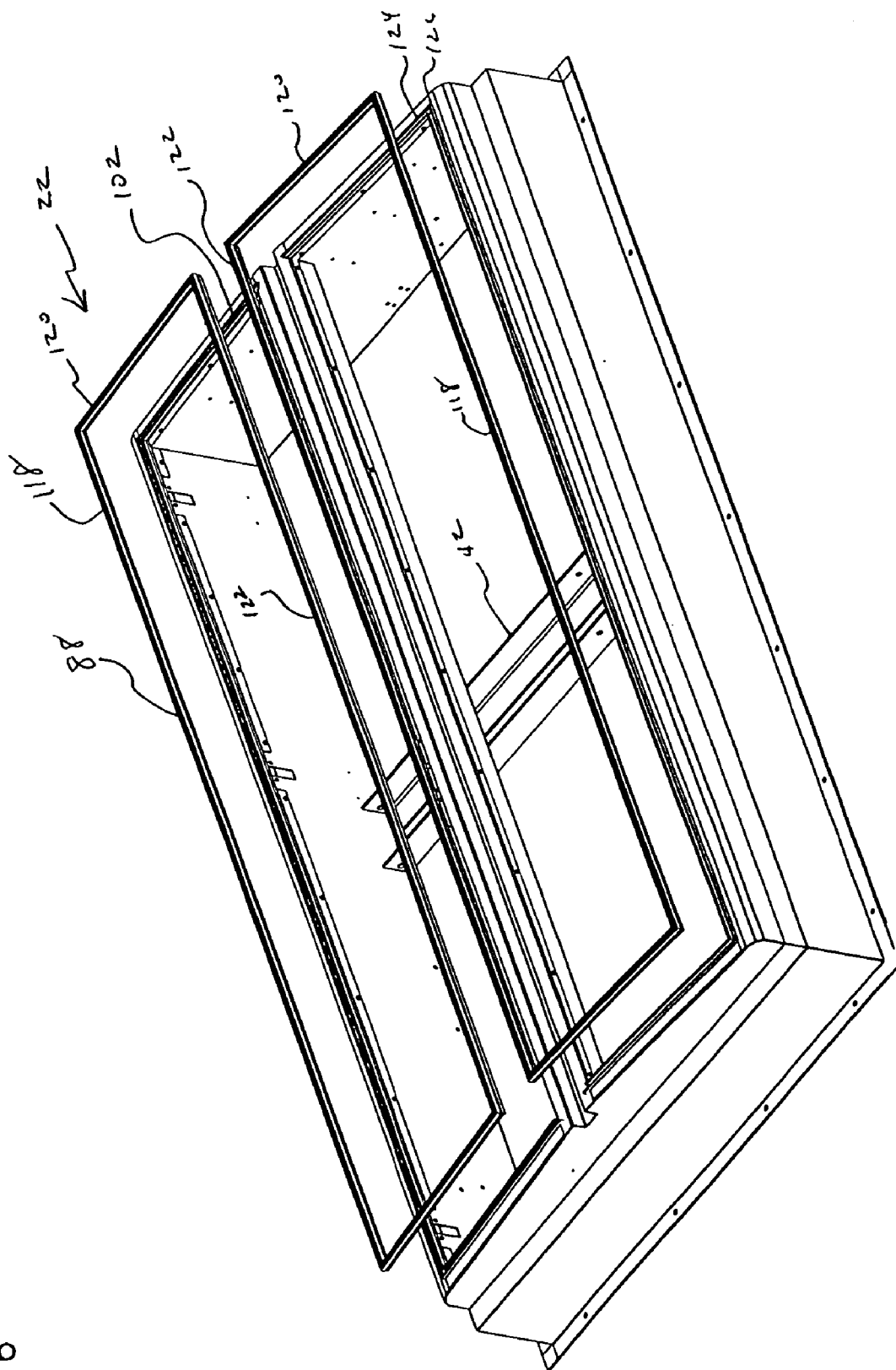

FIG. 6

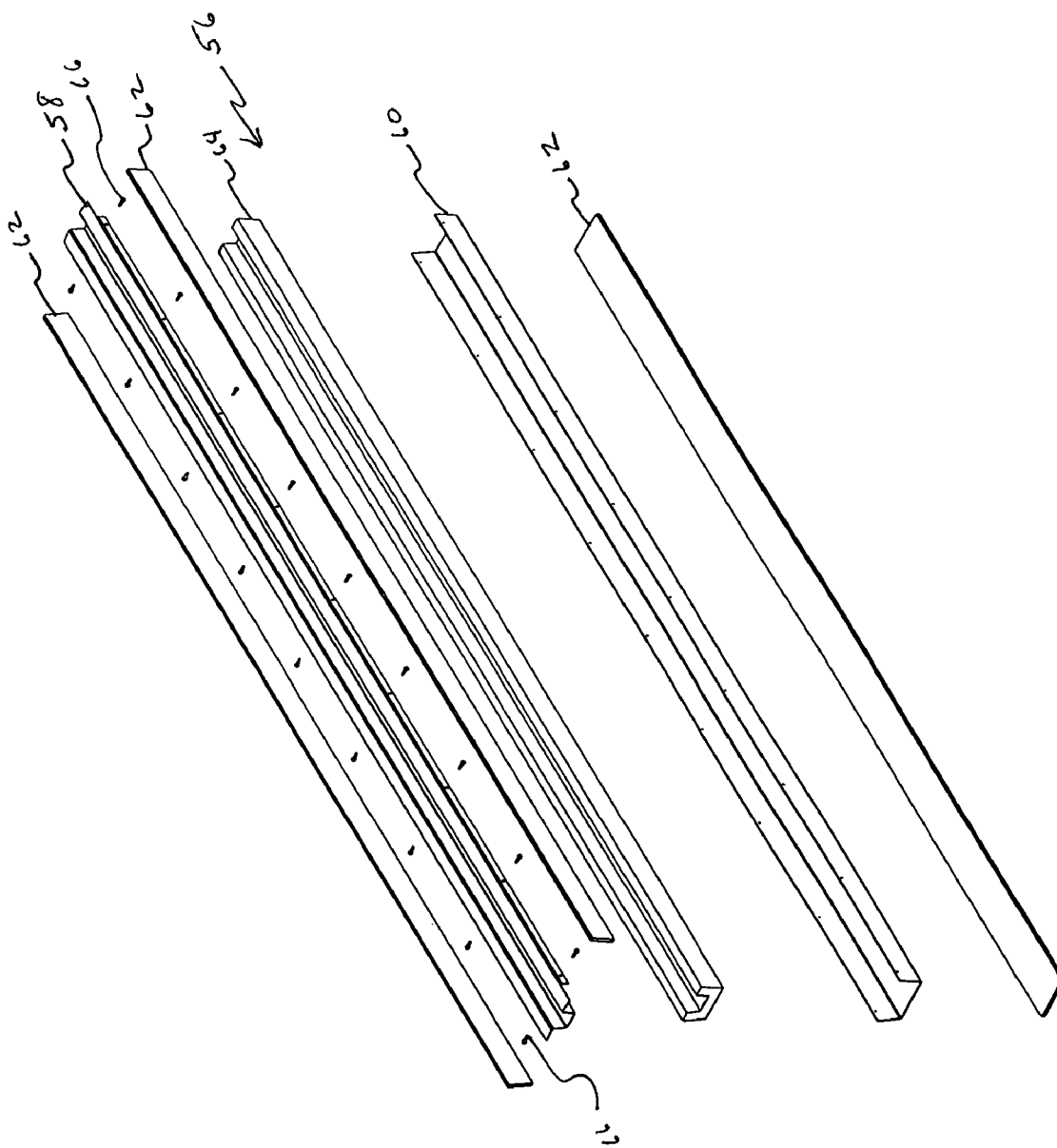
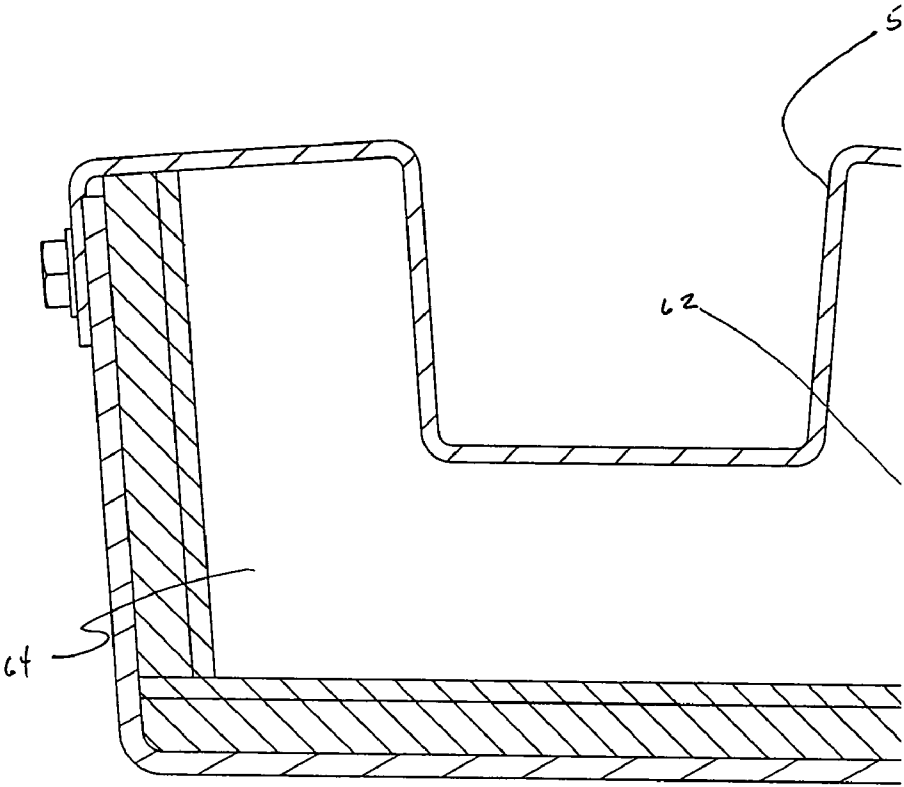

FIG. 7

FIG. 8



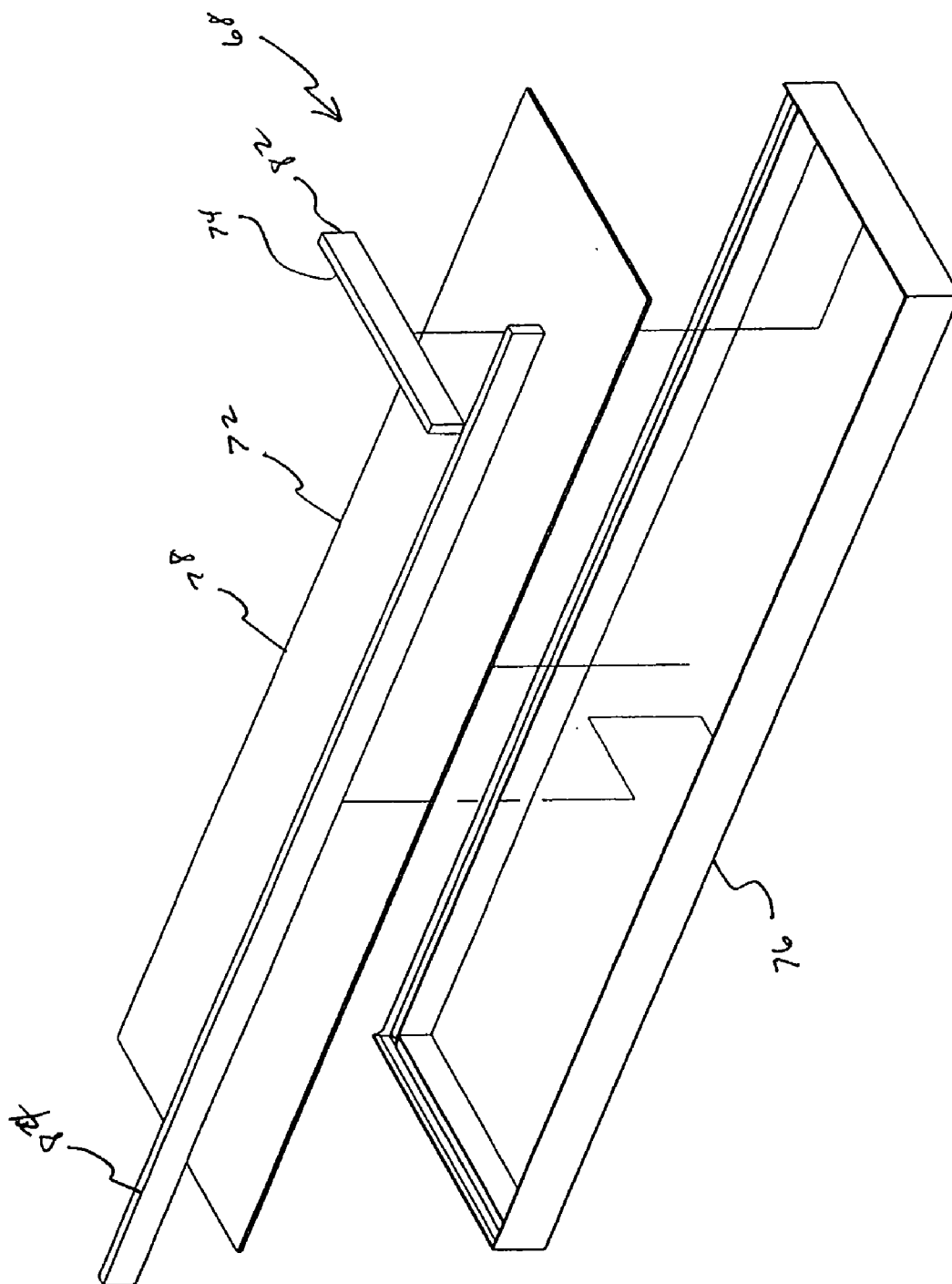

FIG. 9

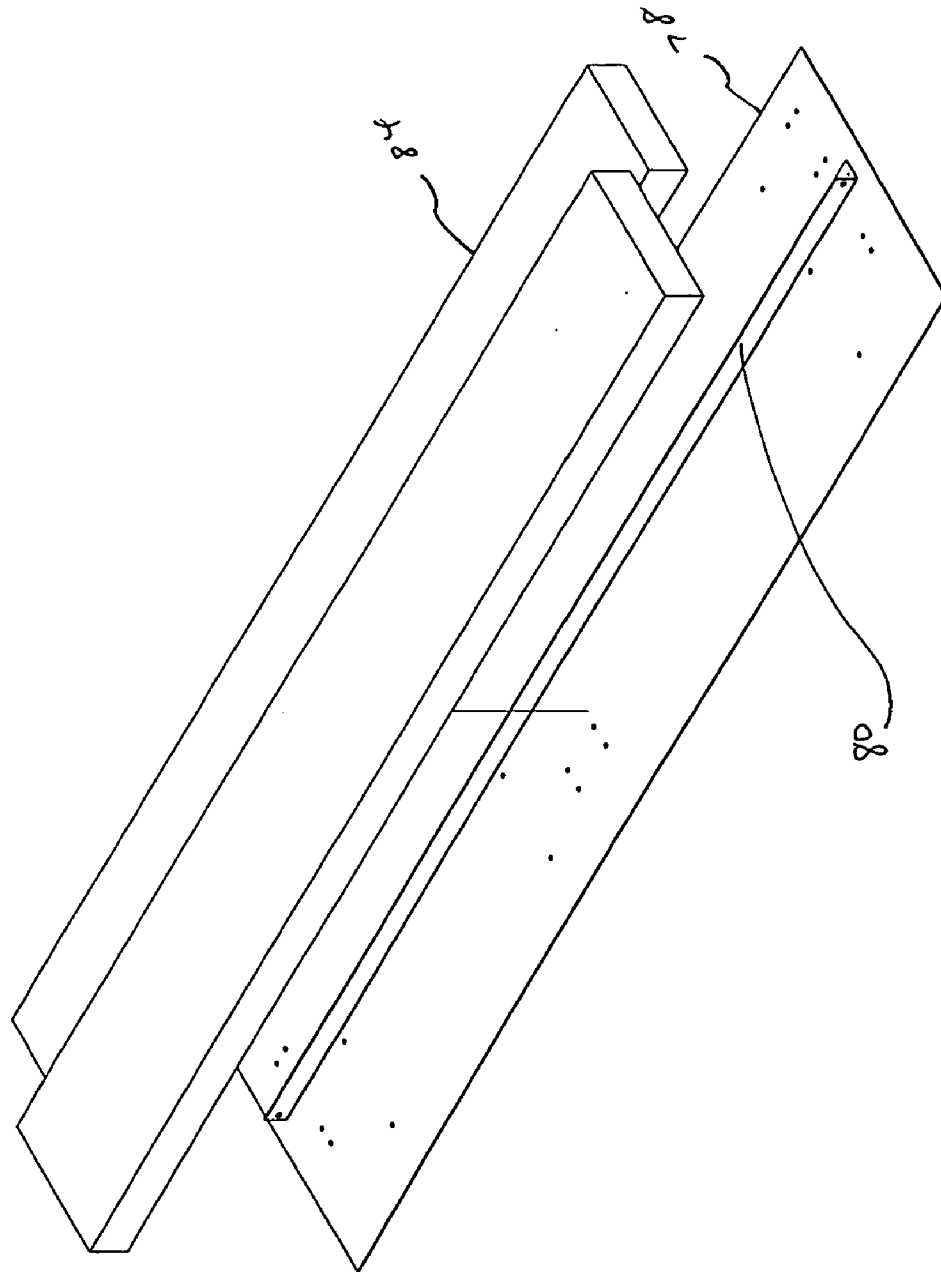

FIG. 10

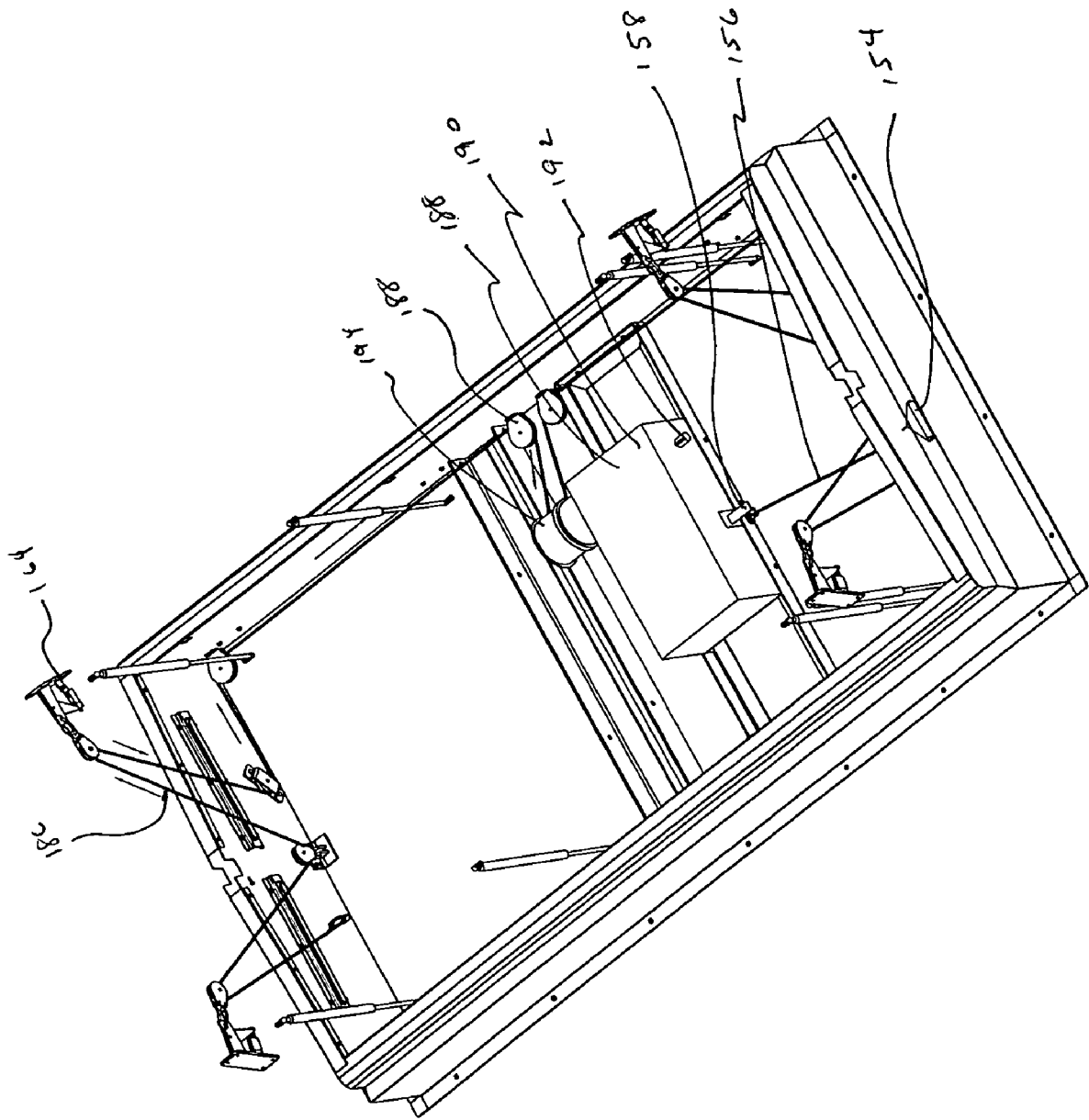

FIG. 12

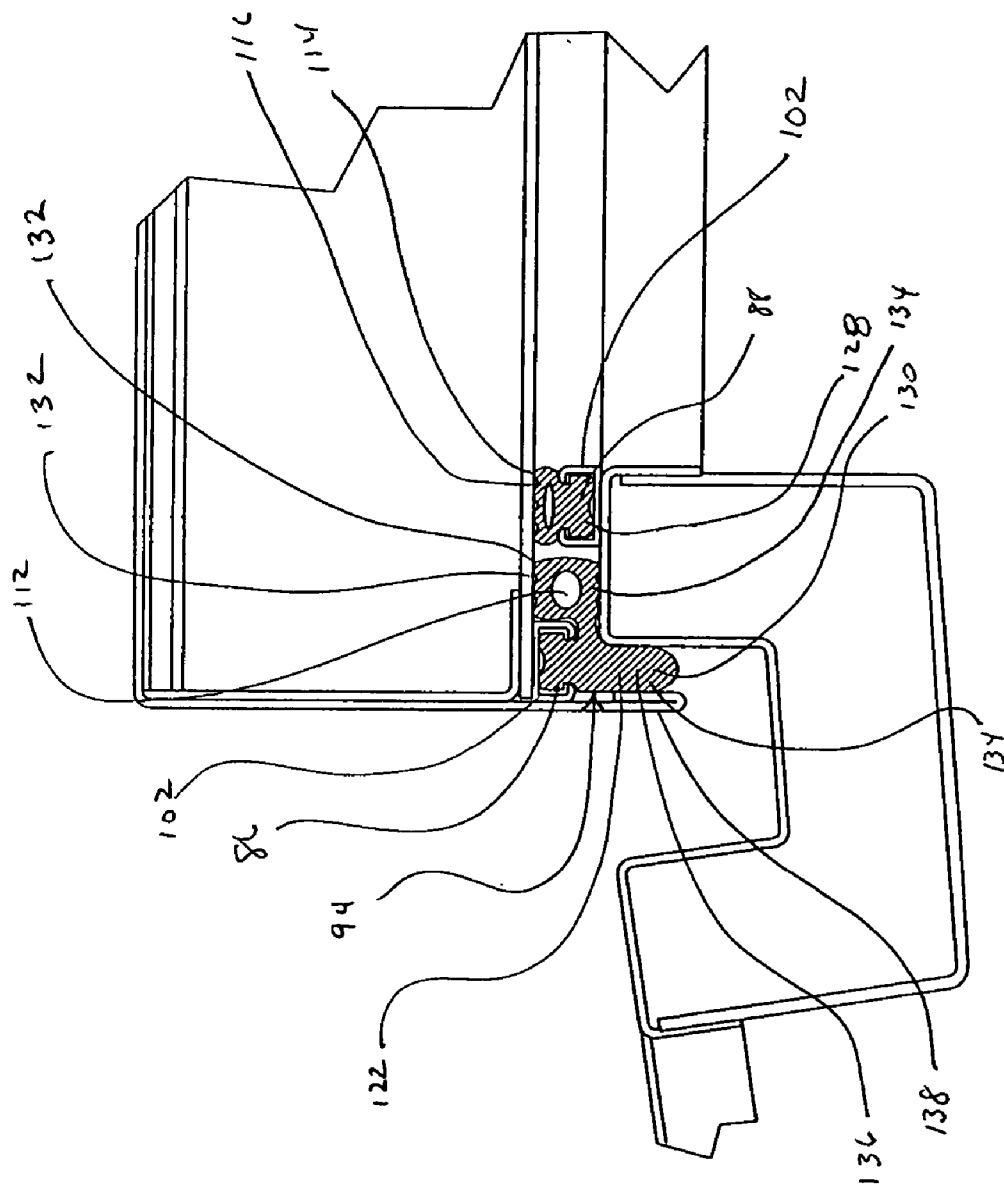

FIG. 13

ACOUSTICAL SMOKE VENT

CLAIM TO PRIORITY

[0001] This application claims priority to U.S. Provisional Patent Application Serial No. 60/439,044 entitled "Acoustical Smoke Vent," filed on Jan. 8, 2003.

FIELD OF THE INVENTION

[0002] The invention relates to roof mounted smoke vents for venting heat, pressure and smoke from a structure during a fire. More particularly, the invention relates to a sound insulated smoke vent with improved acoustical properties for inhibiting sound transmission through the vent when it is in a closed position.

BACKGROUND OF THE INVENTION

[0003] It has been common practice for a long period of time for firefighters to create openings in the upper portions of burning structures in order to vent smoke, heat and pressure. Virtually everyone has seen the image of firefighters breaking upper story windows in buildings to allow the release of the products of combustion. Particularly when dealing with very tall structures, it can be at least inconvenient and often dangerous for firefighters to gain access to the upper parts of a building in order to create ventilation.

[0004] Thus, it has been common for decades in larger structures to provide automatically opening smoke vents on the roof or upper stories of large structures. Roof mounted smoke vents are essentially a door or opening on the roof of a structure. These vents are configured to open automatically upon the occurrence of increased temperature pressure or presence of smoke within the building. In its most basic form, a smoke vent is a spring-loaded door, with the spring-load biased toward an open position. The door is held closed by a fusible link. When the fusible link melts due to excessive heat, the door is released and the spring bias opens the door automatically. More sophisticated release mechanisms have been developed over the years, but this is the basic principle of an automatic smoke vent has remained the same.

[0005] As discussed above, smoke vents are generally equipped with an automated instantaneous opening mechanism. The opening mechanism may be controlled by a fusible link, a remote electrical control or a pneumatic control. These controls are activated by melting of the fusible link, or sensing of an abnormal condition by a temperature sensor, a pressure sensor, a smoke detector or some other similar sensor.

[0006] Conventional smoke vents typically have a door or doors that open directly from the interior of a structure to the ambient atmosphere. A common problem with such smoke vents is that the vent, even when closed, provides an inlet for ambient noise from outside the building. In the case of a structure that includes a theatre or auditorium, this outside noise can create significant distraction and disruption for occupants of the building. This is particularly true if the structure is located near a busy street, a construction site, an airport or another source of chronic noise.

[0007] In addition, the design of some conventional smoke vents causes vibration or interaction, either between the components of the smoke vent itself or between the vent and

the surrounding roof where the smoke vent is mounted. Vibration of this kind is highly disruptive and unwelcome, and is often more disturbing than the noise that triggers it, especially during a concert or performance in an auditorium or theatre.

[0008] When sound waves come into contact with a barrier, some of the energy from the vibrating air molecules transfers to the barrier. This causes the barrier itself to vibrate, which then causes air on the other side of the barrier to be set into motion creating sound waves. The transmission of sound waves through barriers can be reduced in a number of ways. The greater the mass of the barrier, the less sound energy is transmitted through the barrier. In addition, sound transmission can be reduced by the use of sound damping materials. Damping materials are typically limp masses that dampen the sound energy passing through them. Further, sound absorbing materials absorb and trap sound energy. Sound absorbing materials include insulation batts and the like. Finally, the stiffness of the barriers also is a factor in sound transmission. A barrier such as steel may be stiffened to reduce sound transmission.

[0009] The sound transmission of a barrier is commonly rated in terms of Sound Transmission Class, also referred to as Sound Transmission Coefficient (STC). STC is a single-figure rating derived in a prescribed manner from sound transmission loss values. The rating provides an estimate of the performance of a component in common sound insulating situations.

[0010] The higher the STC value, the better the sound deadening performance. For example, an STC 45 barrier will reduce the level of sound heard on the quieter side of the barrier by approximately forty-five decibels from that heard on the noisy side of the barrier. STC values are used to define the sound deadening qualities of a barrier between a sound source area and a sound receiving area.

[0011] A two room test is generally used to determine the sound insulation effectiveness of a construction component. In this test, the component is mounted on a heavily insulated wall. A steady sound is generated on one side of the wall and the sound that passes through the component is measured on the other side. The measurement of sound levels is then recorded at several different frequencies over a range of 125 to 4000 Hz. The difference in sound levels (in dB) between the two sides of the component determines the transmission loss level. For instance, if an 80 dB signal is reduced to 10 dB on the other side of the wall, the transmission loss is 70 dB.

[0012] As an example, an STC value of 50-60 is considered excellent for most structural needs. A barrier having an STC value of 50-60 will prevent most loud sounds from being heard on the other side. An STC value of 40-50 is considered to be very good. On the quiet side of an STC 50 barrier, loud speech will be heard only faintly. At an STC level of 20-25, sound insulation is considered to be very poor, with even quiet speech being audible on the other side of a barrier.

[0013] Sound insulated smoke vents have been developed in an effort to resolve the problem of noise leakage. Commonly, sound insulated smoke vents utilize double layer door designs to minimize acoustic transmission. These acoustical smoke vents will have a door or doors opening

above roof level outside a structure and another set of doors that open at ceiling level inside the structure with a sound insulating space between the doors. Typically the upper set of doors opens outwards at the roof level and the lower set of doors opens into the building space at the ceiling level though other configurations are possible.

[0014] Double layer door designs require more complex opening mechanisms than single layer door designs, and the greater complexity make them more likely to require field adjustment and more prone to jamming and failure. They also require greater maintenance because of the more complex mechanisms.

[0015] When maintenance or testing of such double layer door arrangements is necessary, a maintenance person must often reach down through the open upper level doors to grasp the inner doors to pull them closed to reset them. This can create a significant risk that the maintenance person may fall through the door opening into the building. Theatres and auditoriums where sound insulated smoke vents are typically used, often also have very high ceilings. The combination of these factors can create a risk of serious injury if a maintenance person falls through the door opening.

[0016] Thus, there is a need for an acoustical smoke vent that effectively muffles external noise and increases safety while being simple in operation and construction. In addition, there is a need for an acoustical smoke vent that eliminates the need to have double layer door systems in the smoke vent. Such a smoke vent would be simpler, safer and more reliable than those currently available.

SUMMARY OF THE INVENTION

[0017] The present invention solves most of the above-discussed problems by providing an effective acoustical smoke vent including a single layer door assembly. The acoustical smoke vent of the present invention is sound insulated and the doors are sealed to the curb by a unique labyrinthine gasket assembly effective at limiting sound transmission through the vent. The use of a single layer door system increases safety and reliability and allows for the use of a simple latching and release system.

[0018] The acoustical smoke vent disclosed herein is simpler and safer to reset and close than conventional double layer door smoke vents.

[0019] The acoustical smoke vent of the present invention generally includes a sound insulated curb assembly which is attached to the roof, a single layer sound insulated door assembly, an automatically releasing mechanism to open the door assembly in response to predetermined indicators of fire in the structure, and a labyrinthine seal mechanism which limits sound transmission through the door assembly. The acoustical smoke vent utilizes acoustical materials as well as structural geometry in which the material is located to minimize sound transmission.

[0020] The acoustical smoke vent may also be attached to a wall near the top of a structure. The acoustical smoke vent of the present invention achieves a sound transmission class of STC 45 or better without the need for a double layer door assembly.

[0021] The labyrinthine gasket generally includes a door portion and a curb portion. The door portion of the labyrinthine

gasket runs around and is attached to the inside perimeter of the doors. The curb portion of the gasket surrounds the edge of the curb opening. The door gasket may include double rows of elastomeric gasket material. The hinge side door gasket desirably includes an inner gasket and an outer gasket. The door portion of the labyrinthine gasket is secured to the doors by gasket retainer extrusions.

[0022] In cross-section, the gaskets include an extrusion portion and a sealing portion and define a lumen. The sealing portion desirably defines a series of peaks and troughs to facilitate sealing with the edge surface of the curb.

[0023] The labyrinthine gasket also has a curb portion. The curb portion is desirably secured to the perimeter of the curb opening by gasket retainer extrusions in a fashion similar to the door portion.

[0024] The gasket on the latch side and end sides of the door is unique in construction as compared to the other parts of the labyrinthine gasket. Latch side gasket includes an inner portion and outer portion. The outer portion is secured to the doors via gasket retainer extrusions. The inner portion is integrally formed, as a unit, along with the outer portion but is not otherwise directly secured to the doors. The inner portion includes a door sealing portion and gutter sealing portion. The gutter separates the two doors in a two door embodiment of the invention.

[0025] The door sealing portion and gutter sealing portion include peaks and troughs and define a lumen similar to other parts of the labyrinthine gasket. The outer portion of latch side gasket further includes a cylindrical extension. The cylindrical extension is adapted to overhang into the gutter and over the sides of the curb assembly and to seal thereto. The cylindrical extension may be protected by an overhang of the latch side of the door.

BRIEF DESCRIPTION OF THE DRAWINGS

[0026] FIG. 1 is a perspective view of a partially assembled acoustical smoke vent in accordance with the present invention;

[0027] FIG. 2 is a side elevational view of a curb assembly in accordance with the present invention;

[0028] FIG. 3 is a side sectional view of an acoustical smoke vent in accordance with the present invention;

[0029] FIG. 4 is a perspective view of a curb assembly in accordance with the present invention;

[0030] FIG. 5 is a partially exploded view of a curb assembly;

[0031] FIG. 6 is a perspective partially exploded view of the curb assembly in accordance with the present invention indicating the location of a portion of a labyrinthine gasket;

[0032] FIG. 7 is an exploded perspective view of a gutter assembly;

[0033] FIG. 8 is cross-sectional view of the gutter assembly;

[0034] FIG. 9 is an exploded perspective view of a door;

[0035] FIG. 10 is a partially exploded perspective view of a door assembly;

[0036] FIG. 11 is a partially exploded perspective view of the door assembly;

[0037] FIG. 12 is a partial perspective view of the curb assembly and operating mechanism;

[0038] FIG. 13 is a detailed sectional view of a latch portion of a labyrinthine gasket; and

[0039] FIG. 14 is a detailed sectional view of a hinge portion of the labyrinthine gasket.

DETAILED DESCRIPTION OF THE INVENTION

[0040] Acoustical smoke vent 20 generally includes curb assembly 22, door assembly 24, labyrinthine gasket 26 and actuator assembly 28. Acoustical smoke vent 20 is intended for attachment to the upper portion of a structure. Typically acoustical smoke vent 20 will be secured to the roof of a structure via curb assembly 22. Acoustical smoke vent 20 may also be adapted to be secured to a wall or other part of the upper portion of a structure in order to vent smoke, heat and pressure in the event of a fire or explosion.

[0041] Referring particularly to FIGS. 1, 2, 3 and 5, curb assembly 22 generally includes internal frame 30, exterior flashing 32 and sound insulation 34. As best seen in FIG. 5, frame 30 is a generally rectangular topless and bottomless box including long sides 36 and short sides 38. Long sides 36 and short sides 38 are interconnected and connected to attachment flange 40. Frame 30 may further include angle braces 42. Frame 30 may be assembled from any strong rigid material, but desirably is formed from welded steel or aluminum sheet metal. Frame 30 supports other structures that make up acoustical smoke vent 20.

[0042] Flashing 32 generally covers and surrounds frame 30, leaving an air space in between. Flashing 32 generally includes long sides 44 and short sides 46 joined at comers 48. Preferably, long sides 44 and short sides 36 are joined by welding or other highly weather resistant methods. Flashing 32 further includes flange 50 and is made from a weather resistant material such as aluminum or galvanized steel. Desirably frame 30 and flashing 32 are formed of sheet metal of unequal thickness.

[0043] Referring to FIG. 5, sound insulation 34 for curb assembly 22 typically includes composite acoustic barrier 52 and insulation 54. Composite acoustic barrier 52 is, for example, a composite of loaded vinyl attached to an open cell foam decoupling layer. Insulation 54 is typically R-13 fiberglass or mineral wool.

[0044] Referring to FIGS. 7 and 8, curb assembly 22 may further include counter flash gutter 56. Counter flash gutter 56 includes gutter 58, trough 60, acoustic barrier 62 and insulation 64. Composite acoustic barrier 62 lines the interior of trough 60 and is further separated from gutter 58 by insulation 64. Desirably, counter flash gutter 56 is assembled with rust resistant screws 66. Composite acoustic barrier 62 and insulation 64 are similar to that used in the remainder of acoustical smoke vent 20. Note that gutter 58 and trough 60 are desirable formed of sheet metal of unequal thickness. An internal layer of a first thickness and an external layer of a second thicknesses tend to cancel out resonant frequencies between the layers and to reduce sound transmission.

[0045] Referring to FIGS. 3, 9, 10 and 11, door assembly 24 generally includes one or two doors 68. A larger number of doors 68 may be included. However, two is the most commonly utilized number. Doors 68 are operably connected to curb assembly 22 by hinges 70.

[0046] Referring to FIGS. 3, 9 and 10 doors 68 generally include cover 72 and sound deadening 74. Cover 72 generally includes door pan 76, liner 78 and support angle 80. Door pan 76 and liner 78 serve to completely enclose doors 68 structure. Support angle 80 desirably runs lengthwise through doors 68 and is secured to liner 78 desirably by welding. Referring particularly to FIGS. 9 and 10, door pan 76 and liner 78 surround composite acoustic barrier 82 and insulation 84.

[0047] Door pan 76 is formed from sheet metal of a different thickness from liner 78. For example, door pan 76 may be formed from fourteen gauge (0.079 inch) sheet steel and liner may be formed from twelve gauge (0.108 inch) sheet steel. The difference in thickness of the layers tends to create unequal resonant frequencies between the two structures and to minimize sound transmission. In addition, door pan 76 desirably is isolated from liner 78 as much as possible to minimize sound transmission. Still further, the thickness of the air cavity enclosed by door pan 76 and liner 78 should be maximized as much as practical to reduce sound transmission. For example, a three-inch air space between door pan 76 and liner 78 is desirable. These principles apply to the construction of curb assembly 22 as well.

[0048] Referring to FIGS. 6, 11 and 13 labyrinthine gasket 26 generally includes door portion 86 and curb portion 88. Labyrinthine gasket 26 is formed of a resilient elastomeric material. For example, a suitable elastomeric material is a soft grade closed cell EPDM (ethylene propylene diene monomer) material. Referring particularly to FIG. 11, door portion 86 of labyrinthine gasket 26 runs around perimeter 90 of doors 68. Door portion 86 includes hinge side gasket 92, latch side gasket 94 and end gasket 96. Hinge side gasket 92 desirably includes an inner gasket 98 and an outer gasket 100. Hinge side gasket 92, latch side gasket 94 and end gaskets 96 are all desirably secured to doors 68 by gasket retainer extrusions 102.

[0049] Gasket retainer extrusions 102 are a generally U shaped channel secured to perimeter 90. Gasket retainer extrusions 102 grip labyrinthine gasket 26 and secure it in place. Gasket retainer extrusions 102 may be riveted through liner 78 to fasten them to doors 68.

[0050] Hinge side gasket 92, latch side gasket 94 and end gaskets 96 meet at comers 104. At comers 104 latch side gasket 94 is joined to end gaskets 96 desirably at a 45° mitered joint secured using an adhesive such as Lock-tite 401®. Hinge side gasket 92 is joined to end side gaskets 96 at the hinge side comers in a ninety degree butt joint also joined with an adhesive such as Lock-tite 401®. Desirably, hinge side gasket 92, is of a hollow cross-sectional construction. As best seen in FIG. 3, cross-section 106 includes extrusion portion 108, sealing portion 110 and encloses lumen 112. Sealing portion 110 desirably defines a series of peaks 114 and troughs 116. Extrusion portion 108 is shaped to fit into gasket retainer extrusion 102. Desirably, hinge side gasket 92 is formed of grade zero closed cell EPDM foam. Latch side gasket 94 and end gaskets 96 preferably are grade zero closed cell EPDM foam.

[0051] Referring particularly to FIGS. 6 and 14, curb portion 88 of labyrinthine gasket 26 includes curb hinge side gasket 118, curb end gaskets 120 and gutter gasket 122. Curb hinge side gasket 118, curb end gasket 120 and gutter gasket 122 are desirably secured to opening perimeter 124 by gasket retainer extrusions 102 in a fashion similar to door portion 86. Curb hinge side gasket 118 meets curb end gaskets 120 at opening comers 126. At this joint, curb hinge side gasket 118 is desirably joined to curb end gaskets 120 at a forty five degree miter joint glued together with an adhesive such as Lock-tite 401®. Curb portion 88 of labyrinthine gasket 26 is preferably formed from grade zero closed cell EPDM foam.

[0052] Latch side gasket 94 and end gaskets 96 on door 68 are different in construction as compared to hinge side gasket 92, curb hinge side gasket 118, curb end gasket 120 and gutter gasket 122. Latch side gasket 94 and end gaskets 96 includes inner portion 128 and outer portion 130. Outer portion 130 is secured to doors 68 via gasket retainer extrusions 120. Inner portion 128 is integrally formed along with outer portion 130 but is not otherwise directly secured to doors 68. Inner portion 128 includes door sealing portion 132 and gutter sealing portion 134. Door sealing portion 132 and gutter sealing portion 134 desirably include peaks 114 and troughs 116 and define lumen 112 similar to hinge side gasket 92, end gaskets 96, curb hinge side gaskets 118 and curb end gasket 120. However, inner portion 128 defines door sealing portion 132 and gutter sealing portion 134 on opposed sides of lumen 112. Outer portion 130 of latch side gasket 94 further includes cylindrical extension 136. Cylindrical extension 136 is adapted to overhang into gutter 58 and around opening perimeter 124 of curb assembly 24 to seal thereto. Desirably cylindrical extension 136 is protected by overhang 138 of door 68.

[0053] Referring particularly to FIGS. 1, 3, 11 and 12, actuator 28 generally includes release mechanism 140, opening mechanism 142 and closing mechanism 144. Actuator 28 is connected to sensors (not shown) which sense predetermined indicia of a fire within a structure. Indicia may include smoke, heat or pressure. Such sensors are well known in the art and need not be discussed further here. Release mechanism 140 may commonly include a motor and winch located within acoustical smoke vent 20, a remotely located connected to the acoustical smoke vent 20 by cables or a fusible link based latch mechanism, sometimes known as a pyrolatch.

[0054] In one embodiment, release mechanism 140 includes hook 146, catch 148 and opening controller 150. As best seen in FIG. 3, hook 146 engages catch 148 to hold doors 68 in a closed position. Opening controller 150 controls the operation of catch 148 to automatically open doors 68 in response to predetermined criteria indicating fire within a structure. Opening controller may take the form of a fusible link 151. When exposed to a predetermined elevated temperature fusible link 151 melts and releases hook 146 from catch 148. Other methods of accomplishing this function will be apparent to those skilled in the art. Mechanisms like opening controller 150 are well known in the art and will not be further described here.

[0055] In another embodiment, release mechanism 140 may further include manual release 152. Manual release 152 includes pull handle 154, cable 156 and controller lug 158.

Pull handle 154 is located for convenient access on the exterior of acoustical smoke vent 20. Cable 156 interconnects pull handle 154 with controller lug 158. If it is necessary to manually open acoustical smoke vent 20, a user, such as a firefighter, can grasp and pull pull handle 154, tensioning cable 156, which in turn moves controller lug 158 which releases doors 68 to open acoustical smoke vent 20 overriding automatic systems.

[0056] Opening mechanism 142 generally includes biasing member 160, damping member 162 and hold open 164. Biasing member 160 serves to bias doors 68 toward an open orientation. Biasing member 160 may include springs, weights or systems utilizing compressed gas as well as any other means of biasing doors 68 toward an open position. Desirably, as best seen in FIGS. 1 and 3, biasing member 160 is a gas spring assembly 166. Gas spring assembly 166 includes door bracket 168, curb bracket 170 and gas strut 172. Gas strut 172 interconnects door bracket 168 and curb bracket 170 and provides a biasing force to open doors 68. This arrangement is exemplary and other structures for biasing member 160 will be apparent to individuals skilled in the art.

[0057] Damping member 162 generally includes door bracket 174, shock absorber 176 and attachment 178. Shock absorber 176 interconnects door bracket 174 and attachment 178. Attachment 178 is supported by angle brace 42. Shock absorber 176 is desirably a hydraulic shock absorber or shock absorbers as needed to counteract the biasing force applied by gas spring assembly 166 and allowed doors 68 to open slowly. Damping member 162 counters the tendency of biasing mechanism to slam doors 68 open abruptly. This arrangement is exemplary and other structures for damping member 162 will be apparent to individuals skilled in the art.

[0058] Hold open 164 includes hold open arm 180 and guide track 182. Hold open arm 180 is hingedly attached to doors 68 and slidingly attached to guide track 182. Hold open 164 serves to support door in an open position once it is fully open to prevent unintended closure thereof. Hold open 164 latches in the open position and can be manually released. This arrangement is exemplary and other structures for hold open 164 will be apparent to individuals skilled in the art.

[0059] In another embodiment, opening mechanism 164 and closing mechanism 144 may be combined as best seen in FIG. 12 generally including motor assembly 184, cable 186 and sheaves 188.

[0060] Motor assembly 184 includes motor box 190, shaft 192 and winch drums 194. Motor box houses motor 196 and supports shaft 192. Shaft 192 supports winch drums 194. Winch drums 194 desirably are keyed to shaft 192. In this embodiment opening controller 150 controls motor 196.

[0061] Cables 186 are disposed around winch drums 194 and may be wound onto and paid out from winch drums 194 by motor 196 as commanded by opening controller 150.

[0062] Cables 186 are fed over sheaves 188. Sheaves 188 are located in multiple pulleys 198 as necessary to interconnect cable 186 between winch drums 194 and doors 68 in order to pull doors 68 to a closed position when motor 196 is actuated to turn shaft 192 and winch drums 194. One exemplary configuration for motor 196, winch drums 194, cables 186 and sheaves 188 is shown in FIG. 12. One skilled

in the art can make multiple other arrangements of cables and pulleys in order to accomplish the same task.

[0063] Additionally, closing mechanism 144 may be omitted from acoustical smoke vent 20 and acoustical smoke vent 20 may be manually reclosed as needed.

[0064] In operation, acoustical smoke vent 20 is secured to a structure by attachment flange 40. An opening is made in the roof of the structure appropriately sized to accommodate acoustical smoke vent 20 and attachment flange 40 is secured around the perimeter of the opening. Attachment flange 40 may be secured to the structure by bolts, rivets, nails or other appropriate fasteners depending upon the construction of the structure.

[0065] In the event of a structural fire, actuator 28 is connected to sensors (not shown) which sense predetermined indicia of a fire within a structure. Indicia may include smoke, heat or pressure. Actuator 28 then commands opening mechanism 142 to open doors 68. In one embodiment, opening mechanism 142 moves catch 148 to release hook 146. At which point biasing member 160 which has been applying a biasing force to doors 68 is free to move to open doors 68. Damping member 162, in the form of shock absorbers 176, resists and the force applied by biasing member 160 and slows the motion of doors 68 in order that doors not spring or slam open which could cause potential harm to an individual in the area of acoustical smoke vent 20 or damage acoustical smoke vent 20. In another embodiment, motor 184 is actuated to pay out cables 186 from winch drums 194 to allow biasing member 160 to open doors 68.

[0066] In the event that it is necessary to manually open acoustical smoke vent 20, an operator, such as a firefighter, may grasp pull handle 154 to activate manual release 152. Upon pulling handle 154, cable 156's tension causes motion in controller lug 158 which mechanically releases catch 148 to open doors 68.

[0067] In the event that maintenance is necessary for acoustical smoke vent 20, doors 68 may be opened either remotely or by operation of manual release 152. Once doors 68 are opened, hold open 164 prevents door 68 from closing should it be necessary for maintenance personal to disconnect gas struts 172 and/or shock absorbers 176.

[0068] When it is necessary to close acoustical smoke vent 20, a maintenance person may manually release hold open arm 180 from guide track 182 and manually closed door 68. Alternately, in some embodiments, doors 68 may be closed remotely by actuating motor assembly 184. When motor assembly 184 is actuated, shaft 192 is turned by motor 196 causing winch drums 194 to take up cables 186. Cables 186 pass over a series of sheaves 188 to pull doors 68 closed. In embodiments equipped with a fusible link based latch 151, upon closing, catch 148 engages hook 146 securing doors in a closed position.

[0069] Sound insulation of acoustical smoke vent 20 is achieved by a combination of sound insulation enclosed within doors 68, curb assembly 22, the structure of the acoustical smoke vent 20 and the qualities of labyrinthine gasket 26 as described above. Labyrinthine gasket 26 provides a multilayered acoustic seal between door assembly 24 and curb assembly 22, thus sealing out unwanted acoustic energy that might leak in through gaps between doors 68 and

curb assembly 22. In addition, the thickness of the sheet metal and structure of door assembly 24 and curb assembly 22 in combination with the above discussed factors combine to achieve an STC of forty five or better.

[0070] Further, door assembly 24 is interconnected with curb assembly 22 via hinges 70. Hinges 70 are acoustically isolated from curb assembly 22 by composite acoustic barrier 52 and insulation 54. This contributes further to the sound deadening qualities of the acoustical smoke vent 20. Thus, acoustical smoke vent 20 can achieve a sound transmission class of 45 or better without the need for having a double layer door assembly.

[0071] The present invention may be embodied in other specific forms without departing from the spirit of the essential attributes thereof; therefore, the illustrated embodiments should be considered in all respects as illustrative and not restrictive, reference being made to the appended claims rather than to the foregoing description to indicate the scope of the invention.

What is claimed is:

1. An acoustical smoke vent, comprising:

a curb assembly attachable to a structure

a single layer door assembly operably coupled to the curb assembly;

an automatically releasing latch to secure the single layer door assembly in a closed orientation and to open the single layer door assembly in response to detection of predetermined indicators of fire in the structure; and

wherein the acoustical smoke vent, when in the closed orientation achieves a sound transmission class of STC-45 or better.

2. The acoustical smoke vent as claimed in claim 1, further comprising a labyrinthine seal interposed between the single layer door assembly and the curb assembly.

3. The acoustical smoke vent as claimed in claim 2, the labyrinthine seal comprising a door portion and a curb portion.

4. The acoustical smoke vent as claimed in claim 2, the labyrinthine seal comprising an elastomeric gasket, the door assembly comprising a door having a perimeter and the curb assembly having a rim, a first portion of the elastomeric gasket being disposed about the perimeter and a second portion of the elastomeric gasket being disposed about the rim.

5. The acoustical smoke vent as claimed in claim 2, the labyrinthine seal comprising an elastomeric gasket, the door assembly comprising a door having a perimeter and the curb assembly having a rim, a first portion of the elastomeric gasket being disposed about the perimeter and a second portion of the elastomeric gasket being disposed about the rim, the door portion having two rows of elastomeric gasket on a hinge side thereof.

6. The acoustical smoke vent as claimed in claim 2, the labyrinthine seal comprising an elastomeric gasket, the door assembly comprising a door having a perimeter and the curb assembly having a rim, a first portion of the elastomeric gasket being disposed about the perimeter and a second portion of the elastomeric gasket being disposed about the rim, the door portion having an inner portion and an outer portion.

7. The acoustical smoke vent as claimed in claim 2, the labyrinthine seal comprising an elastomeric gasket, the door assembly comprising a door having a perimeter and the curb assembly having a rim, a first portion of the elastomeric gasket being disposed about the perimeter and a second portion of the elastomeric gasket being disposed about the rim, the door portion having an inner portion and an outer portion, the inner portion having two opposed surfaces, each said surface having peaks and troughs.

8. The acoustical smoke vent as claimed in claim 2, the labyrinthine seal comprising an elastomeric gasket, the door assembly comprising a door having a perimeter and the curb assembly having a rim, a first portion of the elastomeric gasket being disposed about the perimeter and a second portion of the elastomeric gasket being disposed about the rim, the door portion having an inner portion and an outer portion, the inner portion having two opposed surfaces, each said surface having peaks and troughs.

9. The acoustical smoke vent as claimed in claim 2, the labyrinthine seal comprising an elastomeric gasket, the door assembly comprising a door having a perimeter and the curb assembly having a rim, a first portion of the elastomeric gasket being disposed about the perimeter and a second portion of the elastomeric gasket being disposed about the rim, the door portion having an inner portion and an outer portion, the outer portion having a cylindrical extension and being secured to the door.

10. The acoustical smoke vent as claimed in claim 1, further comprising composite acoustic barrier material and insulation disposed within the door assembly and the curb assembly.

11. The acoustical smoke vent as claimed in claim 1, further comprising an inner sheet material layer and an outer sheet material layer separated by an airspace.

12. The acoustical smoke vent as claimed in claim 11 the inner sheet material layer and the outer sheet material layer being of unequal thickness.

13. The acoustical smoke vent as claimed in claim 11 the inner sheet material layer and the outer sheet material layer being acoustically isolated from each other.

14. A method of acoustically insulating a smoke vent, the smoke vent comprising a single layer door assembly and a curb assembly, the single layer door assembly being shiftable between a closed position and an open position, the method comprising the steps of:

interposing a labyrinthine seal between the door assembly and the curb assembly; and

disposing composite acoustic barrier material and insulation within the door assembly and the curb assembly wherein the combination of the labyrinthine seal and composite acoustic barrier material and insulation acoustically insulate the smoke vent, when said door is in said closed position, to a level of STC-45 or better.

15. The method as claimed in claim 14, further comprising the step of securing a first portion of elastomeric gasket to a perimeter of the door assembly and securing a second portion of elastomeric gasket to a rim of the curb assembly.

16. The method as claimed in claim 15, further comprising the step of securing a double row of elastomeric gasket material on a hinge side of the door assembly.

17. The method as claimed in claim 15, further comprising the step of securing a latch side elastomeric gasket to a latch side of the door assembly and forming the latch side

elastomeric gasket to have an inner portion and an outer portion, the inner portion having two opposed surfaces, each said surface having peaks and troughs.

18. The method as claimed in claim 15, further comprising the step of securing a latch side elastomeric gasket to a latch side of the door assembly and forming the latch side elastomeric gasket to have an inner portion and an outer portion, the outer portion having a cylindrical extension and being secured to the door.

19. The method as claimed in claim 14, further comprising the step of forming the door assembly and the curb assembly from an inner sheet material layer and an outer sheet material layer separated by an airspace.

20. The method as claimed in claim 19, further comprising the step of forming the inner sheet material layer and the outer sheet material layer of unequal thickness.

21. The method as claimed in claim 19, further comprising the step of acoustically isolating the inner sheet material layer and the outer sheet material layer from each other.

22. An acoustical smoke vent, comprising:

a curb assembly attachable to a structure

a single layer door assembly;

means for securing the single layer door assembly in a closed orientation and automatically releasing the single layer door assembly in response to detection of predetermined indicators of fire in the structure; and

means for acoustically insulating the smoke vent, when in the closed orientation to a sound transmission class rating of STC-45 or better.

23. The acoustical smoke vent as claimed in claim 22, further comprising means for acoustically sealing between the curb assembly and the door assembly.

24. The acoustical smoke vent as claimed in claim 22, further comprising means for acoustically sealing between the curb assembly and the door assembly and additional means for acoustically sealing around non-hinged edges of the curb assembly.

25. An acoustical smoke vent, comprising:

a curb assembly attachable to a structure, the curb assembly comprising an inner layer, an outer layer, sound insulation and further comprising an opening perimeter;

a door assembly operably coupled to the curb assembly, the door assembly comprising an inner layer, an outer layer, sound insulation and a door perimeter;

an automatically releasing device to secure the door assembly in a closed orientation and to open the door assembly in response to detection of predetermined indicators of smoke or fire in the structure; and

a labyrinthine seal comprising a door portion operably coupled to the door assembly and a curb portion operably coupled to the curb assembly, the door portion being in compressive contact with the opening perimeter when the door is closed and the curb portion being in compressive contact with the door perimeter when the door is closed.

26. The acoustical smoke vent as claimed in claim 25, the labyrinthine seal comprising an elastomeric gasket.

27. The acoustical smoke vent as claimed in claim 25, the door assembly having a hinge side, the labyrinthine seal comprising two rows of elastomeric gasket on the hinge side of the door assembly.

28. The acoustical smoke vent as claimed in claim 25, the labyrinthine seal comprising an elastomeric gasket, the door portion having an inner portion and an outer portion, the inner portion having two opposed surfaces, each said surface having peaks and troughs.

29. The acoustical smoke vent as claimed in claim 25, the labyrinthine seal comprising an elastomeric gasket, the door portion having an inner portion and an outer portion, the outer portion having a cylindrical extension and being secured to the door.

30. The acoustical smoke vent as claimed in claim 25, further comprising a gutter, the gutter comprising composite acoustic barrier material and insulation disposed within.

31. The acoustical smoke vent as claimed in claim 25, the inner layer comprising an inner sheet material layer and the outer layer comprising an outer sheet material layer, the inner sheet material layer and the outer sheet material layer being separated by an airspace.

32. The acoustical smoke vent as claimed in claim 31 the inner sheet material layer and the outer sheet material layer being of unequal thickness.

33. The acoustical smoke vent as claimed in claim 31 the inner sheet material layer and the outer sheet material layer being acoustically isolated from each other.

* * * * *