



(51) International Patent Classification:

A61Q 5/10 (2006.01) *A61K 8/81* (2006.01)
A61K 8/02 (2006.01) *A61K 8/11* (2006.01)
A61K 8/22 (2006.01) *A45D 33/00* (2006.01)

(21) International Application Number:

PCT/EP2017/083442

(22) International Filing Date:

19 December 2017 (19.12.2017)

(25) Filing Language:

English

(26) Publication Language:

English

(30) Priority Data:

1662928 20 December 2016 (20.12.2016) FR

(71) Applicant: L'OREAL [FR/FR]; 14, Rue Royale, 75008 PARIS (FR).

(72) Inventors: MIGNON, Marie; c/o L'OREAL, 11-13 rue Dora Maar, 93400 SAINT OUEN (FR). POURILLE, Chrystel; c/o L'OREAL, 11-13 rue Dora Maar, 93400 SAINT OUEN (FR).

(74) Agent: CASALONGA; 8 avenue Percier, 75008 Paris (FR).

(81) Designated States (unless otherwise indicated, for every kind of national protection available): AE, AG, AL, AM, AO, AT, AU, AZ, BA, BB, BG, BH, BN, BR, BW, BY, BZ, CA, CH, CL, CN, CO, CR, CU, CZ, DE, DJ, DK, DM, DO, DZ, EC, EE, EG, ES, FI, GB, GD, GE, GH, GM, GT, HN, HR, HU, ID, IL, IN, IR, IS, JO, JP, KE, KG, KH, KN, KP, KR, KW, KZ, LA, LC, LK, LR, LS, LU, LY, MA, MD, ME, MG, MK, MN, MW, MX, MY, MZ, NA, NG, NI, NO, NZ, OM, PA, PE, PG, PH, PL, PT, QA, RO, RS, RU, RW, SA,

SC, SD, SE, SG, SK, SL, SM, ST, SV, SY, TH, TJ, TM, TN, TR, TT, TZ, UA, UG, US, UZ, VC, VN, ZA, ZM, ZW.

(84) Designated States (unless otherwise indicated, for every kind of regional protection available): ARIPO (BW, GH, GM, KE, LR, LS, MW, MZ, NA, RW, SD, SL, ST, SZ, TZ, UG, ZM, ZW), Eurasian (AM, AZ, BY, KG, KZ, RU, TJ, TM), European (AL, AT, BE, BG, CH, CY, CZ, DE, DK, EE, ES, FI, FR, GB, GR, HR, HU, IE, IS, IT, LT, LU, LV, MC, MK, MT, NL, NO, PL, PT, RO, RS, SE, SI, SK, SM, TR), OAPI (BF, BJ, CF, CG, CI, CM, GA, GN, GQ, GW, KM, ML, MR, NE, SN, TD, TG).

Published:

— with international search report (Art. 21(3))

(54) Title: ANHYDROUS SOLID COMPOSITION FOR DYEING KERATIN FIBRES COMPRISING A POLYMER COMPRISING AT LEAST ONE HETEROCYCLIC VINYL MONOMER

FIG. 1a

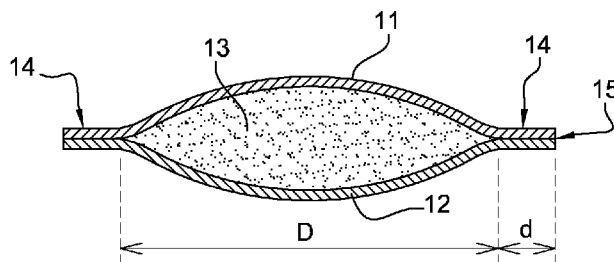

(57) Abstract: The present invention relates to an anhydrous solid composition for dyeing keratin fibres, in particular human keratin fibres such as the hair, comprising a particular chemical oxidizing agent and a polymer comprising at least one heterocyclic vinyl monomer. The present invention also relates to a packaging article containing said composition. The present invention also relates to processes for dyeing keratin fibres using said composition or said packaging article. Finally, the present invention relates to the use of said composition or of said packaging article for dyeing keratin fibres, and in particular human keratin fibres such as the hair.



Anhydrous solid composition for dyeing keratin fibres comprising a polymer comprising at least one heterocyclic vinyl monomer

5 The present invention relates to an anhydrous solid composition for dyeing keratin fibres, in particular human keratin fibres such as the hair, comprising a particular chemical oxidizing agent and a polymer comprising at least one heterocyclic vinyl monomer.

10 The present invention also relates to a packaging article containing said composition.

The present invention also relates to processes for dyeing keratin fibres using said composition or said packaging article.

15 Finally, the present invention relates to the use of said composition or of said packaging article for dyeing keratin fibres, and in particular human keratin fibres such as the hair.

For a long time, hair dyeing, and in particular the masking of grey hair, has been desired by numerous individuals.

20 It is known practice to dye keratin fibres, in particular human keratin fibres such as the hair, to obtain "permanent" colourations with dyeing compositions containing oxidation dye precursors, which are generally known as oxidation bases, such as ortho- or para-phenylenediamines, ortho- or para-aminophenols, or heterocyclic compounds such as pyrazoles, pyrazolinones or pyrazolo-pyridines. These oxidation bases are colourless or weakly coloured compounds, 25 which, when combined with oxidizing products, may give rise to coloured compounds via a process of oxidative condensation.

30 It is also possible to vary the shades obtained with these oxidation bases by combining them with couplers or colour modifiers. The variety of molecules used as oxidation bases and couplers allows a wide range of colours to be obtained on the keratin fibres.

The oxidation dyeing process thus consists in applying to keratin fibres a dyeing composition comprising oxidation bases or a mixture of oxidation bases and couplers with hydrogen peroxide (H_2O_2

or aqueous hydrogen peroxide solution), as oxidizing agent, in leaving it to diffuse, and then in rinsing the fibres thus treated.

5 The colourings resulting therefrom have the advantage of being permanent, strong and resistant to external agents, in particular to light, bad weather, washing, perspiration and rubbing.

10 Although dyeing compositions can be in various galenic forms, such as powders, granules, pastes or creams, they are generally packaged in liquid form. However, solid dyeing compositions bring many advantages compared with liquid dyeing compositions. The process for producing them does not require water, thereby making it possible to adopt a more eco-friendly behaviour, and can also be miniaturized.

The formulations in solid form also make it possible to use raw materials that are unstable or have low stability in liquid formulation.

15 However, the solid dyeing compositions currently on the market exhibit, after several weeks of storage, problems of stability which result in a premature oxidation of the dyes and a decrease in dyeing performance qualities once the composition is used. Moreover, once oxidized, the composition has a tendency to turn dark, which is not popular with consumers.

20 In order to overcome this stability problem, dyeing compositions in solid form, comprising oxidation dye precursors and sodium percarbonate stabilized by coatings, have been proposed. These coatings make the powder water-insoluble. The user is then provided with a foaming lotion with the dyeing composition in order to enable redispersion of the powder.

However, the final mixture exhibits residual grains and is difficult to apply to keratin fibres, which results in unsatisfactory colourings.

30 In other solid dyeing compositions, sodium percarbonate has been replaced with sodium perborate, which is easier to stabilize. However, sodium perborate is less well-tolerated by consumers than sodium percarbonate, and has a worse toxicological profile.

At the current time, there is no dyeing composition in solid form that is satisfactory in terms of stability and that has a degree of dyeing quality similar to liquid dyeing compositions.

Thus, there is a real need to provide solid dyeing compositions which do not have the abovementioned drawbacks, *i.e.* which remain stable over time and which retain their dyeing properties.

These compositions must also lead to chromatic, powerful, intense and sparingly selective colourings, that is to say colourings that are uniform along the length of the keratin fibre.

The applicant has discovered, surprisingly, that a solid dyeing composition comprising one or more oxidation bases, one or more particular chemical oxidizing agents, and one or more polymers comprising at least one heterocyclic vinyl monomer makes it possible to achieve the objectives set out above, in particular to obtain a solid dyeing composition that is stable over time, and the dyeing properties of which are maintained even after several months of storage.

A subject of the present invention is in particular an anhydrous solid composition for dyeing keratin fibres, in particular human keratin fibres such as the hair, comprising:

- (a) one or more oxidation bases,
- (b) one or more chemical oxidizing agents chosen from alkali metal percarbonates, alkaline-earth metal percarbonates and mixtures thereof,
- (c) one or more polymers comprising at least one heterocyclic vinyl monomer, and
- (d) optionally one or more oxidation couplers.

The presence of a polymer comprising at least one heterocyclic vinyl monomer makes it possible to limit the oxidation of the composition, thus improving its stability over time. The composition thus stabilized retains its dyeing properties.

Moreover, the presence of this polymer makes it possible to avoid coating the oxidizing agent. The ready-to-use composition, resulting from the mixing of the anhydrous solid dyeing composition according to the invention with a cosmetically acceptable medium,

then has a uniform texture with no residual grains. It can then be more easily applied to keratin fibres and enables a uniform coverage of the fibres.

5 Thus, the anhydrous solid dyeing composition according to the invention makes it possible to produce chromatic, powerful, intense and sparingly selective colourings, even after several months of storage.

A subject of the present invention is also a packaging article comprising:

- 10 i) an envelope defining at least one cavity, the envelope comprising water-soluble and/or liposoluble fibres, preferably water-soluble fibres; and
- ii) an anhydrous solid dyeing composition as defined previously; it being understood that the anhydrous solid dyeing composition is in
- 15 one of the cavities defined by the envelope i).

The present invention also relates to a process for dyeing keratin fibres, in particular human keratin fibres such as the hair, comprising the following successive steps:

- 20 - applying to said keratin fibres a ready-to-use composition resulting from the mixing of an anhydrous solid dyeing composition, as defined previously, and of a cosmetically acceptable medium,
- leaving the ready-to-use composition on said keratin fibres,
- rinsing said keratin fibres, and
- optionally shampooing said keratin fibres, rinsing them and drying
- 25 them.

A subject of the present invention is also a process for dyeing keratin fibres, in particular human keratin fibres such as the hair, comprising the following successive steps:

- 30 - mixing a packaging article, as defined previously, with a composition that is capable of dissolving the envelope of said packaging article,
- applying the resulting composition to said keratin fibres,
- leaving said resulting composition on said keratin fibres,
- rinsing said keratin fibres, and

- optionally shampooing said keratin fibres, rinsing them and drying them.

5 The present application also relates to the use of an anhydrous solid dyeing composition, as defined previously, for dyeing keratin fibres, and in particular human keratin fibres such as the hair.

The present invention also relates to the use of a packaging article, as defined previously, for dyeing keratin fibres, and in particular human keratin fibres such as the hair.

10 Other subjects, characteristics, aspects and advantages of the invention will emerge even more clearly on reading the description and the examples that follow.

In the text hereinbelow, and unless otherwise indicated, the limits of a range of values are included within that range, especially in the expressions “between” and “ranging from ... to ...”.

15 Moreover, the expressions “at least one” and “at least” used in the present description are equivalent to the expressions “one or more” and “greater than or equal to”, respectively.

20 The term “keratin materials” preferably denotes human keratin materials, such as the skin, the scalp and keratin fibres that are human, and more preferentially the hair.

25 The term “anhydrous composition” is intended to mean a composition comprising a water content of less than 3% by weight, preferably less than 1% by weight, relative to the weight of the composition. Preferably, this water content is less than 0.5% by weight relative to the weight of the composition. More particularly, the water content ranges from 0 to 1% by weight and preferably from 0 to 0.5% by weight relative to the total weight of the composition. Finally, more particularly, it does not comprise water.

30 The term “solid composition” is intended to mean a composition that can be in powder, paste or particle form (for example spherical particles such as small balls).

The term “powder” is intended to mean a composition in pulverulent form, which is preferably essentially free of dust (or fine particles). In other words, the particle size distribution of the particles

is such that the weight ratio of particles less than or equal to 100 micrometres in size (fines content) and preferably less than or equal to 65 micrometres in size (fines content) is advantageously less than or equal to 5%, preferably less than 2% and more particularly less than 5
1 1% (particle size evaluated using a Retsch AS 200 Digit particle size analyser; oscillation height: 1.25 mm/screening time: 5 minutes). Advantageously, the particle size is between 100 μm and 3 mm and more particularly between 65 μm and 2 mm.

10 The term "paste" is intended to mean a composition with a viscosity of greater than 5 poises and preferably greater than 10 poises, measured at 25°C and at a shear rate of 1s^{-1} ; this viscosity may be determined using a cone-plate rheometer.

15 The term "particles" is intended to mean small fractionated objects formed from solid particles aggregated together, of variable shapes and sizes. They may have a regular or irregular shape. They may in particular have a spherical shape (such as granules, granular material, balls), a square shape, a rectangular shape, or an elongated shape such as rods. Spherical particles are quite particularly preferred.

20 The size of the particles can be, in the largest dimension thereof, between 0.01 and 5 mm, preferably between 0.1 and 2.5 mm, and better still between 0.5 and 2 mm.

The anhydrous solid composition according to the invention can be in the form of a compressed solid composition, in particular compressed using a manual or mechanical press.

25

Anhydrous solid dyeing composition

Oxidation bases (a)

30 The anhydrous solid dyeing composition according to the present invention comprises one or more oxidation bases. Preferably, the oxidation bases are chosen especially from heterocyclic bases and benzene-based bases, the addition salts thereof, the solvates thereof, and mixtures thereof.

The oxidation bases that may be used in the composition of the invention are chosen especially from para-phenylenediamines,

bis(phenyl)alkylenediamines, para-aminophenols, ortho-aminophenols and heterocyclic bases, the addition salts thereof, the solvates thereof, and mixtures thereof.

Among the para-phenylenediamines that may be mentioned are,
5 for example, para-phenylenediamine, para-toluenediamine, 2-chloro-para-phenylenediamine, 2,3-dimethyl-para-phenylenediamine, 2,6-dimethyl-para-phenylenediamine, 2,6-diethyl-para-phenylenediamine, 2,5-dimethyl-para-phenylenediamine, N,N-dimethyl-para-phenylenediamine, N,N-diethyl-para-phenylenediamine, N,N-dipropyl-para-phenylenediamine, 4-amino-N,N-diethyl-3-methylaniline, N,N-
10 bis(β -hydroxyethyl)-para-phenylenediamine, 4-N,N-bis(β -hydroxyethyl)amino-2-methylaniline, 4-N,N-bis(β -hydroxyethyl)amino-2-chloroaniline, 2- β -hydroxyethyl-para-phenylenediamine, 2-methoxymethyl-para-phenylenediamine, 2-fluoro-para-phenylenediamine, 2-isopropyl-para-phenylenediamine, N-(β -hydroxypropyl)-para-phenylenediamine, 2-hydroxymethyl-para-phenylenediamine, N,N-dimethyl-3-methyl-para-phenylenediamine, N-ethyl-N-(β -hydroxyethyl)-para-phenylenediamine, N-(β,γ -dihydroxypropyl)-para-phenylenediamine, N-(4'-aminophenyl)-para-phenylenediamine, N-phenyl-para-phenylenediamine, 2- β -hydroxyethyloxy-para-phenylenediamine, 2- β -acetaminoethyloxy-para-phenylenediamine, N-(β -methoxyethyl)-para-phenylenediamine, 4-aminophenylpyrrolidine, 2-thienyl-para-phenylenediamine, 2- β -hydroxyethylamino-5-aminotoluene and 3-hydroxy-1-(4'-aminophenyl)pyrrolidine and the corresponding addition salts with an
25 acid.

Among the abovementioned para-phenylenediamines, preference is more particularly given to para-phenylenediamine, para-toluenediamine, 2-isopropyl-para-phenylenediamine, 2- β -hydroxyethyl-para-phenylenediamine, 2- β -hydroxyethyloxy-para-phenylenediamine, 2,6-dimethyl-para-phenylenediamine, 2,6-diethyl-para-phenylenediamine, 2,3-dimethyl-para-phenylenediamine, N,N-bis(β -hydroxyethyl)-para-phenylenediamine, 2-chloro-para-

phenylenediamine and 2- β -acetylaminoethoxy-para-phenylenediamine and the corresponding addition salts with an acid.

Among the bis(phenyl)alkylenediamines that may be mentioned are for example N,N'-bis(β -hydroxyethyl)-N,N'-bis(4'-aminophenyl)-
5 1,3-diaminopropanol, N,N'-bis(β -hydroxyethyl)-N,N'-bis(4'-aminophenyl)ethylenediamine, N,N'-bis(4-aminophenyl)tetramethylenediamine, N,N'-bis(β -hydroxyethyl)-N,N'-bis(4-aminophenyl)tetramethylenediamine, N,N'-bis(4-methylaminophenyl)tetramethylenediamine, N,N'-bis(4-methylaminophenyl)tetramethylenediamine, N,N'-bis(ethyl)-N,N'-
10 bis(4'-amino-3'-methylphenyl)ethylenediamine and 1,8-bis(2,5-diaminophenoxy)-3,6-dioxaoctane and the corresponding addition salts.

Among the para-aminophenols that are mentioned are for example para-aminophenol, 4-amino-3-methylphenol, 4-amino-3-
15 fluorophenol, 4-amino-3-chlorophenol, 4-amino-3-hydroxymethylphenol, 4-amino-2-methylphenol, 4-amino-2-hydroxymethylphenol, 4-amino-2-methoxymethylphenol, 4-amino-2-aminomethylphenol, 4-amino-2-(β -hydroxyethylaminomethyl)phenol and 4-amino-2-fluorophenol and the corresponding addition salts with
20 an acid.

Among the ortho-aminophenols that may be mentioned, for example, are 2-aminophenol, 2-amino-5-methylphenol, 2-amino-6-methylphenol and 5-acetamido-2-aminophenol, and the corresponding addition salts.

25 Among the heterocyclic bases that may be mentioned, for example, are pyridine, pyrimidine and pyrazole derivatives.

Among the pyridine derivatives that may be mentioned are the compounds described, for example, in patents GB 1 026 978 and GB 1 153 196, for example 2,5-diaminopyridine, 2-(4-methoxyphenyl)amino-3-aminopyridine and 3,4-diaminopyridine, and
30 the corresponding addition salts.

Other pyridine oxidation bases that are useful in the present invention are the 3-aminopyrazolo[1,5-a]pyridine oxidation bases or the corresponding addition salts described, for example, in patent

application FR 2 801 308. Examples that may be mentioned include pyrazolo[1,5-a]pyrid-3-ylamine, 2-acetylamino pyrazolo[1,5-a]pyrid-3-ylamine, 2-(morpholin-4-yl)pyrazolo[1,5-a]pyrid-3-ylamine, 3-aminopyrazolo[1,5-a]pyridine-2-carboxylic acid, 2-methoxy pyrazolo[1,5-a]pyrid-3-ylamine, (3-aminopyrazolo[1,5-a]pyrid-7-yl)methanol, 2-(3-aminopyrazolo[1,5-a]pyrid-5-yl)ethanol, 2-(3-aminopyrazolo[1,5-a]pyrid-7-yl)ethanol, (3-aminopyrazolo[1,5-a]pyrid-2-yl)methanol, 3,6-diaminopyrazolo[1,5-a]pyridine, 3,4-diaminopyrazolo[1,5-a]pyridine, pyrazolo[1,5-a]pyridine-3,7-diamine, 7-(morpholin-4-yl)pyrazolo[1,5-a]pyrid-3-ylamine, pyrazolo[1,5-a]pyridine-3,5-diamine, 5-(morpholin-4-yl)pyrazolo[1,5-a]pyrid-3-ylamine, 2-[(3-aminopyrazolo[1,5-a]pyrid-5-yl)(2-hydroxyethyl)amino]ethanol, 2-[(3-aminopyrazolo[1,5-a]pyrid-7-yl)(2-hydroxyethyl)amino]ethanol, 3-aminopyrazolo[1,5-a]pyridin-5-ol, 3-aminopyrazolo[1,5-a]pyridin-4-ol, 3-aminopyrazolo[1,5-a]pyridin-6-ol, 3-aminopyrazolo[1,5-a]pyridin-7-ol, 2- β -hydroxyethoxy-3-aminopyrazolo[1,5-a]pyridine and 2-(4-dimethylpiperazinium-1-yl)-3-aminopyrazolo[1,5-a]pyridine, and the corresponding addition salts.

More particularly, the oxidation bases that are useful in the present invention are chosen from 3-aminopyrazolo[1,5-a]pyridines and are preferably substituted on carbon atom 2 with:

- a) a (di)(C₁-C₆)(alkyl)amino group, said alkyl group possibly being substituted with at least one hydroxyl, amino or imidazolium group;
- b) an optionally cationic 5- to 7-membered heterocycloalkyl group comprising from 1 to 3 heteroatoms, optionally substituted with one or more (C₁-C₆)alkyl groups such as a di(C₁-C₄)alkylpiperazinium group; or
- c) a (C₁-C₆)alkoxy group optionally substituted with one or more hydroxyl groups, such as a β -hydroxyalkoxy group, and the corresponding addition salts.

Among the 3-aminopyrazolo[1,5-a]pyridine bases, it will in particular be preferred to use 2[(3-aminopyrazolo[1,5-a]pyridin-2-yl)oxy]ethanol, and/or 4-(3-aminopyrazolo[1,5-a]pyridin-2-yl)-1,1-

dimethylpiperazin-1-ium chloride and/or the corresponding addition salts or solvates thereof.

Among the pyrimidine derivatives that may be mentioned are the compounds described, for example, in patents DE 2359399; JP 88-169571; JP 05-63124; EP 0770375 or patent application WO 96/15765, such as 2,4,5,6-tetraaminopyrimidine, 4-hydroxy-2,5,6-triaminopyrimidine, 2-hydroxy-4,5,6-triaminopyrimidine, 2,4-dihydroxy-5,6-diaminopyrimidine, 2,5,6-triaminopyrimidine and the addition salts thereof and the tautomeric forms thereof, when a tautomeric equilibrium exists.

Among the pyrazole derivatives that may be mentioned are the compounds described in patents DE 3843892 and DE 4133957 and patent applications WO 94/08969, WO 94/08970, FR-A-2 733 749 and DE 195 43 988, for instance 4,5-diamino-1-methylpyrazole, 4,5-diamino-1-(β -hydroxyethyl)pyrazole, 3,4-diaminopyrazole, 4,5-diamino-1-(4'-chlorobenzyl)pyrazole, 4,5-diamino-1,3-dimethylpyrazole, 4,5-diamino-3-methyl-1-phenylpyrazole, 4,5-diamino-1-methyl-3-phenylpyrazole, 4-amino-1,3-dimethyl-5-hydrazinopyrazole, 1-benzyl-4,5-diamino-3-methylpyrazole, 4,5-diamino-3-tert-butyl-1-methylpyrazole, 4,5-diamino-1-tert-butyl-3-methylpyrazole, 4,5-diamino-1-(β -hydroxyethyl)-3-methylpyrazole, 4,5-diamino-1-ethyl-3-methylpyrazole, 4,5-diamino-1-ethyl-3-(4'-methoxyphenyl)pyrazole, 4,5-diamino-1-ethyl-3-hydroxymethylpyrazole, 4,5-diamino-3-hydroxymethyl-1-methylpyrazole, 4,5-diamino-3-hydroxymethyl-1-isopropylpyrazole, 4,5-diamino-3-methyl-1-isopropylpyrazole, 4-amino-5-(2'-aminoethyl)amino-1,3-dimethylpyrazole, 3,4,5-triaminopyrazole, 1-methyl-3,4,5-triaminopyrazole, 3,5-diamino-1-methyl-4-methylaminopyrazole and 3,5-diamino-4-(β -hydroxyethyl)amino-1-methylpyrazole, and the corresponding addition salts. Use may also be made of 4,5-diamino-1-(β -methoxyethyl)pyrazole.

A 4,5-diaminopyrazole will preferably be used and even more preferentially 4,5-diamino-1-(β -hydroxyethyl)pyrazole and/or a corresponding salt.

The pyrazole derivatives that may also be mentioned include diamino-N,N-dihydropyrazolopyrazolones and in particular those described in patent application FR-A-2 886 136, such as the following compounds and the corresponding addition salts: 2,3-diamino-6,7-dihydro-1H,5H-pyrazolo[1,2-a]pyrazol-1-one, 2-amino-3-ethylamino-6,7-dihydro-1H,5H-pyrazolo[1,2-a]pyrazol-1-one, 2-amino-3-isopropylamino-6,7-dihydro-1H,5H-pyrazolo[1,2-a]pyrazol-1-one, 2-amino-3-(pyrrolidin-1-yl)-6,7-dihydro-1H,5H-pyrazolo[1,2-a]pyrazol-1-one, 4,5-diamino-1,2-dimethyl-1,2-dihydropyrazol-3-one, 4,5-diamino-1,2-diethyl-1,2-dihydropyrazol-3-one, 4,5-diamino-1,2-bis(2-hydroxyethyl)-1,2-dihydropyrazol-3-one, 2-amino-3-(2-hydroxyethyl)amino-6,7-dihydro-1H,5H-pyrazolo[1,2-a]pyrazol-1-one, 2-amino-3-dimethylamino-6,7-dihydro-1H,5H-pyrazolo[1,2-a]pyrazol-1-one, 2,3-diamino-5,6,7,8-tetrahydro-1H,6H-pyridazino[1,2-a]pyrazol-1-one, 4-amino-1,2-diethyl-5-(pyrrolidin-1-yl)-1,2-dihydropyrazol-3-one, 4-amino-5-(3-dimethylaminopyrrolidin-1-yl)-1,2-diethyl-1,2-dihydropyrazol-3-one and 2,3-diamino-6-hydroxy-6,7-dihydro-1H,5H-pyrazolo[1,2-a]pyrazol-1-one.

Use will preferably be made of 2,3-diamino-6,7-dihydro-1H,5H-pyrazolo[1,2-a]pyrazol-1-one and/or a corresponding salt.

Use will preferably be made of 4,5-diamino-1-(β -hydroxyethyl)pyrazole and/or 2,3-diamino-6,7-dihydro-1H,5H-pyrazolo[1,2-a]pyrazol-1-one and/or 2[(3-aminopyrazolo[1,5-a]pyridin-2-yl)oxy]ethanol and/or 4-(3-aminopyrazolo[1,5-a]pyridin-2-yl)-1,1-dimethylpiperazin-1-ium chloride and/or the corresponding salts or solvates thereof as heterocyclic bases.

In general, the addition salts of oxidation bases that may be used in the composition according to the invention are chosen in particular from the addition salts with an acid such as the hydrochlorides, hydrobromides, sulfates, citrates, succinates, tartrates, lactates, tosylates, benzenesulfonates, phosphates and acetates.

Moreover, the solvates of the oxidation bases more particularly represent the hydrates of said bases and/or the combination of said bases with a linear or branched C₁ to C₄ alcohol such as methanol,

ethanol, isopropanol or n-propanol. Preferably, the solvates are hydrates.

Preferably, the oxidation base(s) are chosen from para-phenylenediamines, bis(phenyl)alkylenediamines, para-aminophenols, 5 bis-para-aminophenols, ortho-aminophenols and heterocyclic bases, the addition salts thereof, the solvates thereof, and mixtures thereof.

More preferentially, the oxidation base(s) are chosen from para-phenylenediamines, the addition salts thereof, the solvates thereof, and mixtures thereof.

10 The total amount of oxidation base(s) present in the anhydrous solid dyeing composition according to the present invention preferably ranges from 0.1% to 30% by weight, more preferentially from 0.5% to 15% by weight and better still from 1% to 10% by weight, relative to the total weight of the anhydrous solid dyeing composition.

15 *Chemical oxidizing agents (b)*

The anhydrous solid dyeing composition according to the present invention also comprises one or more chemical oxidizing agents chosen from alkali metal percarbonates, alkaline-earth metal percarbonates and mixtures thereof.

20 Preferably, the chemical oxidizing agents present in the anhydrous solid dyeing composition according to the invention are anhydrous, and more preferentially anhydrous and solid, that is to say in the form of a powder, of a paste or of particles (such as balls).

25 Preferably, the chemical oxidizing agent is sodium percarbonate.

The total amount of chemical oxidizing agent(s), chosen from alkali metal percarbonates, alkaline-earth metal percarbonates and mixtures thereof, present in the anhydrous solid dyeing composition according to the present invention, preferably ranges from 30% to 55% 30 by weight and more preferentially from 35% to 50% by weight, relative to the total weight of the anhydrous solid dyeing composition.

The composition according to the invention may optionally also comprise one or more additional chemical oxidizing agents that are

different from the chemical oxidizing agents (b), as defined previously.

5 The term “chemical oxidizing agent” is intended according to the invention to mean an oxidizing agent other than atmospheric oxygen.

10 The additional chemical oxidizing agent(s), optionally present in the anhydrous solid dyeing composition according to the invention, are preferably anhydrous, and more preferentially anhydrous and solid, that is to say in the form of a powder, of a paste or of particles (such as balls).

15 More particularly, the additional anhydrous chemical oxidizing agent(s) are chosen from (i) peroxygenated salts, for instance persulfates, perborates, peracids and precursors thereof; (ii) alkali metal bromates or ferricyanides; (iii) solid hydrogen peroxide-generating chemical oxidizing agents such as urea peroxide and polymer complexes that can release hydrogen peroxide, especially those comprising a heterocyclic vinyl monomer such as polyvinylpyrrolidone/H₂O₂ complexes, in particular in powder form, which are different from the polymer comprising at least one
20 heterocyclic vinyl monomer (c), as defined below; (iv) oxidases that produce hydrogen peroxide in the presence of a suitable substrate (for example glucose in the case of glucose oxidase or uric acid with uricase); and mixtures thereof.

25 According to one particular embodiment, the additional chemical oxidizing agent(s) are chosen from complexes of hydrogen peroxide and of polymer containing as monomer at least one heterocyclic vinyl monomer different from the polymer comprising at least one heterocyclic vinyl monomer (c) as defined below.

30 More particularly, the heterocyclic vinyl monomer is chosen from monomers comprising a 4- to 6-membered heterocycle, optionally fused to a benzene ring and comprising from 1 to 4 identical or different intracyclic heteroatoms; the number of intracyclic heteroatoms being less than the number of ring members of the

heterocycle. Preferably, the number of intracyclic heteroatoms is 1 or 2.

5 More particularly, the heteroatom(s) are chosen from sulfur, oxygen and nitrogen, preferably from nitrogen and oxygen. In accordance with an even more advantageous embodiment of the invention, the monomer comprises at least one intracyclic nitrogen atom.

The vinyl heterocycle may optionally be substituted with one or more C₁ to C₄ and preferably C₁ to C₂ alkyl groups.

10 Preferably, the heterocyclic monomer is chosen from N-vinyl monomers.

Among the monomers that may be envisaged, mention may be made of the following optionally substituted monomers: N-vinylpyrrolidone, vinylcaprolactam, N-vinylpiperidone, N-vinyl-3-morpholine, N-vinyl-4-oxazolinone, 2-vinylpyridine, 4-vinylpyridine, 2-vinylquinoline, 1-vinylimidazole and 1-vinylcarbazole. Preferably, the monomer is optionally substituted N-vinylpyrrolidone.

In accordance with one particularly advantageous embodiment of the invention, the polymer is a homopolymer.

20 However, it is not excluded to use a copolymer. In such a case, the comonomer(s) are chosen from vinyl acetate, (meth)acrylic acids, (meth)acrylamides and C₁ to C₄ alkyl esters of (meth)acrylic acid, which may be substituted or unsubstituted.

The polymer participating in this complex is preferably water-soluble. It may have variable average molecular weights, preferably between 10³ and 3×10⁶ g/mol, and more preferentially between 10³ and 2×10⁶ g/mol. It is also possible to use mixtures of such polymers.

25 Advantageously, said complex comprises from 10% to 30% by weight, preferably from 13% to 25% by weight and more preferentially from 18% to 22% by weight of hydrogen peroxide relative to the total weight of the complex.

30 According to an even more advantageous variant of the invention, in this complex, the mole ratio between the heterocyclic

vinyl monomer(s) and the hydrogen peroxide ranges from 0.5 to 2 and preferably from 0.5 to 1.

This complex is advantageously in the form of a substantially anhydrous powder.

5 Complexes of this type are especially described in US 5 008 106, US 5 077 047, EP 832 846, EP 714 919, DE 4344131 and DE 195 45 380 and the other polymer complexes described in US 5 008 093, US 3 376 110 and US 5 183 901.

10 Examples of complexes that may be mentioned include products such as Peroxydone K-30, Peroxydone K-90 and Peroxydone XL-10 and also complexes formed with hydrogen peroxide and one of the following polymers such as Plasdone K-17, Plasdone K-25, Plasdone K-29/32, Plasdone K-90, Polyplasdone INF-10, Polyplasdone XL-10, Polyplasdone XL, Plasdone S-630, Styleze 2000 Terpolymer
15 and the series of Ganex copolymers, sold by the company ISP.

 Preferably, the composition according to the present invention can comprise one or more anhydrous solid additional chemical oxidizing agents, which are different from the chemical oxidizing agents (b), chosen from urea peroxide, perborates, persulfates and
20 mixtures thereof.

 According to one particularly preferred embodiment, the anhydrous solid dyeing composition according to the present invention does not comprise any additional chemical oxidizing agent which is different from the oxidizing agents (b).

25 *Polymers comprising at least one heterocyclic vinyl monomer (c)*

 The anhydrous solid dyeing composition according to the present invention also comprises one or more polymers comprising at least one heterocyclic vinyl monomer.

30 More particularly, the heterocyclic vinyl monomer is chosen from monomers comprising a 4- to 7-membered heterocycle, and comprising from 1 to 4 identical or different intracyclic heteroatoms, which is optionally fused to a benzene ring and/or optionally

substituted; the number of intracyclic heteroatoms being less than the number of ring members of the heterocycle.

Preferably, the number of intracyclic heteroatoms is 1 or 2.

5 More particularly, the heteroatom(s) are chosen from sulfur, oxygen and nitrogen, and preferably from nitrogen and oxygen.

In accordance with an even more advantageous embodiment of the invention, the monomer comprises at least one intracyclic nitrogen atom.

10 The vinyl heterocycle may optionally be substituted with one or more C₁ to C₄ and preferably C₁ to C₂ alkyl groups.

Preferably, the heterocyclic monomer is chosen from N-vinyl monomers.

15 Among the heterocyclic vinyl monomers that may be envisaged, mention may advantageously be made of the following optionally substituted monomers: N-vinylpyrrolidone, vinylcaprolactam, N-vinylpiperidone, N-vinyl-3-morpholine, N-vinyl-4-oxazolinone, 2-vinylpyridine, 4-vinylpyridine, 2-vinylquinoline, 1-vinylimidazole and 1-vinylcarbazole. Preferably, the monomer is optionally substituted N-vinylpyrrolidone.

20 In accordance with one particularly advantageous embodiment of the invention, the polymer is a homopolymer.

25 However, it is not excluded to use a copolymer. The copolymer can comprise at least two distinct heterocyclic vinyl monomers as described previously, or else at least one heterocyclic vinyl monomer, as described previously, and at least one monomer that is different from the heterocyclic vinyl monomers, as described previously.

30 In the latter case, the comonomer(s) are preferably chosen from vinyl acetate, (meth)acrylic acids, (meth)acrylamides and C₁ to C₄ alkyl esters of (meth)acrylic acid, which may be substituted or unsubstituted.

The polymer comprising at least one heterocyclic vinyl monomer may be crosslinked or non-crosslinked.

The polymer comprising at least one heterocyclic vinyl monomer according to the invention is preferably water-soluble. It

may have variable average molecular weights, preferably between 10^3 and 3×10^6 g/mol, and more preferentially between 10^3 and 2×10^6 g/mol. It is also possible to use mixtures of such polymers.

5 Preferably, the polymer comprising at least one heterocyclic vinyl monomer is the crosslinked or non-crosslinked vinylpyrrolidone homopolymer.

The total amount of polymer(s) comprising at least one heterocyclic vinyl monomer, present in the anhydrous solid dyeing composition according to the present invention, preferably ranges from 10 5% to 70% by weight, more preferentially from 10% to 60% by weight and better still from 10% to 35% by weight, relative to the total weight of the anhydrous solid dyeing composition.

Oxidation couplers (d)

15 The anhydrous solid dyeing composition according to the present invention can optionally also comprise one or more oxidation couplers conventionally used for dyeing keratin fibres.

Among these oxidation couplers, mention may be made in particular of meta-phenylenediamines, meta-aminophenols, meta-diphenols, naphthalene-based couplers and heterocyclic couplers, the 20 addition salts thereof, the solvates thereof, and mixtures thereof.

Examples that may be mentioned include resorcinol, 2-methyl-5-hydroxyethylaminophenol, 2,4-diaminophenoxyethanol, 1,3-dihydroxybenzene, 1,3-dihydroxy-2-methylbenzene, 4-chloro-1,3-dihydroxybenzene, 2,4-diamino-1-(β -hydroxyethyloxy)benzene, 2-amino-4-(β -hydroxyethylamino)-1-methoxybenzene, 1,3-diaminobenzene, 1,3-bis(2,4-diaminophenoxy)propane, 3-ureidoaniline, 3-ureido-1-dimethylaminobenzene, sesamol, 1- β -hydroxyethylamino-3,4-methylenedioxybenzene, α -naphthol, 2-methyl-1-naphthol, 6-hydroxyindole, 4-hydroxyindole, 4-hydroxy-N-methylindole, 2-amino-3-hydroxypyridine, 6-hydroxybenzomorpholine, 3,5-diamino-2,6-dimethoxypyridine, 1-N-(β -hydroxyethyl)amino-3,4-methylenedioxybenzene, 2,6-bis(β -hydroxyethylamino)toluene, 6-hydroxyindoline, 2,6-dihydroxy-4-methylpyridine, 1-H-3-methylpyrazol-5-one, 1-phenyl-3-methylpyrazol-5-one, 2,6-

5 dimethylpyrazolo[1,5-b]-1,2,4-triazole, 2,6-dimethyl[3,2-c]-1,2,4-triazole and 6-methylpyrazolo[1,5-a]benzimidazole, 2-methyl-5-aminophenol, 5-N-(β -hydroxyethyl)amino-2-methylphenol, 3-aminophenol (or meta-aminophenol) and 3-amino-2-chloro-6-methylphenol, the corresponding addition salts with an acid and the corresponding mixtures.

10 Preferably, the coupler(s) are chosen from meta-phenylenediamines, meta-aminophenols, the addition salts thereof, and mixtures thereof, and more preferentially from 2,4-diaminophenoxyethanol, resorcinol, meta-aminophenol, the addition salts thereof, the solvates thereof, and mixtures thereof.

15 The addition salts of the oxidation couplers optionally present in the composition according to the invention are chosen especially from the addition salts with an acid, such as the hydrochlorides, hydrobromides, sulfates, citrates, succinates, tartrates, lactates, tosylates, benzenesulfonates, phosphates and acetates, and the addition salts with a base such as sodium hydroxide, potassium hydroxide, ammonia, amines or alkanolamines.

20 Moreover, the solvates of the oxidation couplers more particularly represent the hydrates of said couplers and/or the combination of said couplers with a linear or branched C₁ to C₄ alcohol such as methanol, ethanol, isopropanol or n-propanol. Preferably, the solvates are hydrates.

25 The total amount of oxidation coupler(s), when they are present in the anhydrous solid dyeing composition according to the invention, preferably ranges from 0.1% to 25% by weight, more preferentially from 0.5% to 20% by weight and better still from 1% to 19% by weight, relative to the total weight of the anhydrous solid dyeing composition.

30 *Surfactants*

The anhydrous solid dyeing composition according to the present invention can optionally also comprise one or more surfactants, preferably chosen from anionic surfactants, amphoteric or

zwitterionic surfactants, non-ionic surfactants, cationic surfactants and mixtures thereof.

For the purposes of the present invention, the term “surfactant” is intended to mean an agent comprising at least one hydrophilic group and at least one lipophilic group in its structure, and which is preferably capable of reducing the surface tension of water, and comprising in its structure, as optional repeating units, only alkylene oxide units and/or sugar units and/or siloxane units. Preferably, the lipophilic group is a fatty chain comprising from 8 to 30 carbon atoms.

Preferably, the anhydrous solid dyeing composition according to the present invention comprises one or more surfactants chosen from anionic surfactants.

The term “anionic surfactant” is intended to mean a surfactant comprising, as ionic or ionizable groups, only anionic groups. These anionic groups are preferably chosen from the groups $-C(O)OH$, $-C(O)O^-$, $-SO_3H$, $-S(O)_2O^-$, $-OS(O)_2OH$, $-OS(O)_2O^-$, $-P(O)OH_2$, $-P(O)_2O^-$, $-P(O)O_2^-$, $-P(OH)_2$, $=P(O)OH$, $-P(OH)O^-$, $=P(O)O^-$, $=POH$ and $=PO^-$, the anionic parts comprising a cationic counterion such as those derived from an alkali metal, an alkaline-earth metal, an amine or an ammonium.

As examples of anionic surfactants that may be used in the composition according to the invention, mention may be made of alkyl sulfates, alkyl ether sulfates, alkylamido ether sulfates, alkylaryl polyether sulfates, monoglyceride sulfates, alkylsulfonates, alkylamidesulfonates, alkylarylsulfonates, α -olefin sulfonates, paraffin sulfonates, alkyl sulfosuccinates, alkyl ether sulfosuccinates, alkylamide sulfosuccinates, alkyl sulfoacetates, acylsarcosinates, acylglutamates, alkyl sulfosuccinamates, acylisethionates and N-acyltaurates, polyglycoside-polycarboxylic acid and alkyl monoester salts, acyl lactylates, salts of D-galactoside uronic acids, salts of alkyl ether carboxylic acids, salts of alkylaryl ether carboxylic acids, salts of alkylamido ether carboxylic acids; and the corresponding non-salified forms of all these compounds; the alkyl and acyl groups of all

these compounds comprising from 6 to 24 carbon atoms and the aryl group denoting a phenyl group.

These compounds may be oxyethylenated and then preferably comprise from 1 to 50 ethylene oxide units.

5 The salts of C₆ to C₂₄ alkyl monoesters of polyglycoside-polycarboxylic acids may be chosen from C₆ to C₂₄ alkyl polyglycoside-citrates, C₆ to C₂₄ alkyl polyglycoside-tartrates and C₆ to C₂₄ alkyl polyglycoside-sulfosuccinates.

10 When the anionic surfactant(s) are in salt form, they may be chosen from alkali metal salts such as the sodium or potassium salt and preferably the sodium salt, ammonium salts, amine salts and in particular amino alcohol salts or alkaline-earth metal salts such as the magnesium salts.

15 Examples of amino alcohol salts that may in particular be mentioned include monoethanolamine, diethanolamine and triethanolamine salts, monoisopropanolamine, diisopropanolamine or triisopropanolamine salts, 2-amino-2-methyl-1-propanol salts, 2-amino-2-methyl-1,3-propanediol salts and tris(hydroxymethyl)aminomethane salts.

20 Use is preferably made of alkali metal or alkaline-earth metal salts, and in particular sodium or magnesium salts.

25 Among the anionic surfactants mentioned, use is preferably made of (C₆-C₂₄)alkyl sulfates, (C₆-C₂₄)alkyl ether sulfates comprising from 2 to 50 ethylene oxide units, especially in the form of alkali metal, ammonium, amino alcohol and alkaline-earth metal salts, or a mixture of these compounds.

30 In particular, it is preferred to use (C₁₂-C₂₀)alkyl sulfates, (C₁₂-C₂₀)alkyl ether sulfates comprising from 2 to 20 ethylene oxide units, especially in the form of alkali metal, ammonium, amino alcohol and alkaline-earth metal salts, or a mixture of these compounds. Even better still, it is preferred to use sodium lauryl ether sulfate, in particular those containing 2.2 mol of ethylene oxide, more preferentially (C₁₂-C₂₀)alkyl sulfates such as an alkali metal lauryl sulfate such as sodium lauryl sulfate.

Preferably, the anhydrous solid dyeing composition according to the present invention comprises one or more surfactants chosen from amphoteric or zwitterionic surfactants.

5 The amphoteric or zwitterionic surfactant(s) of the invention are preferably non-silicone, and are in particular derivatives of optionally quaternized aliphatic secondary or tertiary amines, in which derivatives the aliphatic group is a linear or branched chain comprising from 8 to 22 carbon atoms, said amine derivatives containing at least one anionic group, for instance a carboxylate, 10 sulfonate, sulfate, phosphate or phosphonate group. Mention may be made in particular of (C₈-C₂₀)alkyl betaines, sulfobetaines, (C₈-C₂₀)alkylamido(C₃-C₈)alkyl betaines and (C₈-C₂₀)alkylamido(C₆-C₈)alkyl sulfobetaines.

15 Among the amphoteric or zwitterionic surfactants mentioned above, use is preferably made of (C₈-C₂₀)alkyl betaines such as coco betaine, and (C₈-C₂₀)alkylamido(C₃-C₈)alkyl betaines such as cocamidopropyl betaine, and mixtures thereof. More preferentially, the amphoteric or zwitterionic surfactant(s) are chosen from cocamidopropyl betaine and coco betaine.

20 Preferably, the anhydrous solid dyeing composition according to the present invention comprises one or more surfactants chosen from cationic surfactants.

The cationic surfactant(s) that may be used in the composition according to the invention comprise, for example, optionally 25 polyoxyalkylenated primary, secondary or tertiary fatty amine salts, quaternary ammonium salts, and mixtures thereof.

30 Among the cationic surfactants that may be present in the composition according to the invention, it is more particularly preferred to choose cetyltrimethylammonium, behenyltrimethylammonium and dipalmitoylethylhydroxyethylmethylammonium salts, and mixtures thereof, and more particularly behenyltrimethylammonium chloride, cetyltrimethylammonium chloride, and dipalmitoylethylhydroxyethylammonium methosulfate, and mixtures thereof.

Preferably, the anhydrous solid dyeing composition according to the present invention comprises one or more surfactants chosen from non-ionic surfactants.

5 Examples of non-ionic surfactants that may be used in the composition according to the invention are described, for example, in the "Handbook of Surfactants" by M.R. Porter, published by Blackie & Son (Glasgow and London), 1991, pp. 116-178.

Examples of non-ionic surfactants that may be mentioned include:

- 10 - oxyalkylenated (C₈-C₂₄)alkylphenols;
- saturated or unsaturated, linear or branched, oxyalkylenated or glycerolated C₈ to C₃₀ alcohols;
- saturated or unsaturated, linear or branched, oxyalkylenated C₈ to C₃₀ amides;
15 - esters of saturated or unsaturated, linear or branched, C₈ to C₃₀ acids and of polyethylene glycols;
- polyoxyethylenated esters of saturated or unsaturated, linear or branched, C₈ to C₃₀ acids and of sorbitan;
- esters of fatty acids and of sucrose;
20 - (C₈-C₃₀)alkylpolyglycosides, (C₈-C₃₀)alkenylpolyglycosides, optionally oxyalkylenated (0 to 10 oxyalkylene units) and comprising 1 to 15 glucose units, (C₈-C₃₀)alkylglucoside esters;
- saturated or unsaturated oxyethylenated plant oils;
- condensates of ethylene oxide and/or of propylene oxide, *inter alia*,
25 alone or as mixtures;
- N-(C₈-C₃₀)alkylglucamine and N-(C₈-C₃₀)acylmethylglucamine derivatives;
- aldobionamides;
- amine oxides; and
30 - oxyethylenated and/or oxypropylenated silicones.

The surfactants contain a number of moles of ethylene oxide and/or of propylene oxide ranging advantageously from 1 to 100, more particularly from 2 to 100, preferably from 2 to 50 and more

advantageously from 2 to 30. Advantageously, the non-ionic surfactants do not comprise any oxypropylene units.

In accordance with a preferred embodiment of the invention, the non-ionic surfactants are chosen from oxyethylenated C₈ to C₃₀ alcohols comprising from 1 to 100 mol and more particularly from 2 to 100 mol of ethylene oxide; polyoxyethylenated esters of saturated or unsaturated, linear or branched C₈ to C₃₀ acids and of sorbitan comprising from 1 to 100 mol and better still from 2 to 100 mol of ethylene oxide.

As examples of monoglycerolated or polyglycerolated non-ionic surfactants, monoglycerolated or polyglycerolated C₈ to C₄₀ alcohols are preferably used.

In particular, the monoglycerolated or polyglycerolated C₈ to C₄₀ alcohols preferably correspond to formula (A8) below:



in which:

- R₂₉ represents a linear or branched C₈ to C₄₀ and preferably C₈ to C₃₀ alkyl or alkenyl radical; and

- m represents a number ranging from 1 to 30 and preferably from 1 to 10.

As examples of compounds of formula (A8) that are suitable for use in the context of the invention, mention may be made of lauryl alcohol containing 4 mol of glycerol (INCI name: Polyglyceryl-4 Lauryl Ether), lauryl alcohol containing 1.5 mol of glycerol, oleyl alcohol containing 4 mol of glycerol (INCI name: Polyglyceryl-4 Oleyl Ether), oleyl alcohol containing 2 mol of glycerol (INCI name: Polyglyceryl-2 Oleyl Ether), cetearyl alcohol comprising 2 mol of glycerol, cetearyl alcohol comprising 6 mol of glycerol, oleocetyl alcohol comprising 6 mol of glycerol and octadecanol comprising 6 mol of glycerol.

The alcohol of formula (A8) may represent a mixture of alcohols in the same way that the value of m represents a statistical value, which means that, in a commercial product, several species of polyglycerolated fatty alcohols may coexist in the form of a mixture.

Among the monoglycerolated or polyglycerolated alcohols, it is more particularly preferred to use the C₈ to C₁₀ alcohol containing 1 mol of glycerol, the C₁₀ to C₁₂ alcohol containing 1 mol of glycerol and the C₁₂ alcohol containing 1.5 mol of glycerol.

5 Preferentially, the non-ionic surfactant used in the process of the invention in the composition is a monooxyalkylenated or polyoxyalkylenated, particularly monooxyethylenated or polyoxyethylenated, or monooxypropylenated or polyoxypropylenated, non-ionic surfactant, or a combination thereof, more particularly
10 monooxyethylenated or polyoxyethylenated, monoglycerolated or polyglycerolated surfactants and alkylpolyglucosides.

More preferably still, the non-ionic surfactants are chosen from polyoxyethylenated sorbitan esters, polyoxyethylenated fatty alcohols and alkylpolyglucosides, and mixtures thereof.

15 More preferentially, the anhydrous solid dyeing composition according to the present invention comprises one or more surfactants chosen from anionic surfactants, non-ionic surfactants and mixtures thereof, and more preferentially from anionic surfactants and mixtures thereof.

20 *Alkaline agents*

The anhydrous solid dyeing composition according to the present invention may optionally also comprise one or more alkaline agents.

25 The alkaline agent(s) can be chosen from silicates and metasilicates such as alkali metal metasilicates, carbonates or hydrogen carbonates of alkali metals or alkaline-earth metals, such as lithium, sodium, potassium, magnesium, calcium or barium, and mixtures thereof.

30 The alkaline agent(s) can also be chosen from ammonium salts, and in particular inorganic ammonium salts.

Preferably, the ammonium salt(s) are chosen from ammonium halides, such as ammonium chloride, ammonium sulfate, ammonium phosphate, ammonium nitrate and mixtures thereof.

More preferentially, the ammonium salt is ammonium chloride or ammonium sulfate.

5 In one preferred embodiment, the anhydrous solid dyeing composition according to the present invention comprises one or more alkaline agents.

Even more preferentially, the anhydrous solid dyeing composition according to the present invention comprises one or more ammonium salts, preferably chosen from ammonium chloride or ammonium sulfate, better still ammonium sulfate.

10 *Thickening polymers*

The anhydrous solid dyeing composition according to the present invention may optionally also comprise one or more thickening polymers.

15 Advantageously, the thickening polymer(s) are chosen from the following polymers:

- (a) non-ionic amphiphilic polymers comprising at least one fatty chain and at least one hydrophilic unit;
- (b) anionic amphiphilic polymers comprising at least one hydrophilic unit and at least one fatty-chain unit;
- 20 (c) crosslinked acrylic acid homopolymers;
- (d) crosslinked homopolymers of 2-acrylamido-2-methylpropanesulfonic acid, and crosslinked acrylamide copolymers thereof which are partially or totally neutralized;
- (e) ammonium acrylate homopolymers or copolymers of ammonium acrylate and of acrylamide;
- 25 (f) dimethylaminoethyl methacrylate homopolymers quaternized with methyl chloride or dimethylaminoethyl methacrylate copolymers quaternized with methyl chloride and acrylamide; and
- (g) polysaccharides such as:
 - 30 (g1) scleroglucan gums (biopolysaccharide of microbial origin);
 - (g2) gums derived from plant exudates, such as gum arabic, ghatti gum, karaya gum or gum tragacanth;
 - (g3) celluloses and derivatives;
 - (g4) guar gums and derivatives; or

(g5) starches or derivatives.

It should be noted that, in the case of the present invention, the thickening polymers act on the viscosity of the ready-to-use composition, that is to say of the composition comprising the anhydrous solid dyeing composition according to the present invention and a cosmetically acceptable medium.

According to the invention, amphiphilic polymers are more particularly hydrophilic polymers that are capable, in the medium of the composition, and more particularly in an aqueous medium, of reversibly combining with each other or with other molecules.

Their chemical structure more particularly comprises at least one hydrophilic group and at least one hydrophobic group. The term "hydrophobic group" is intended to mean a radical or polymer bearing a saturated or unsaturated, linear or branched hydrocarbon-based chain, comprising at least 8 carbon atoms, preferably at least 10 carbon atoms, more preferentially from 10 to 30 carbon atoms, in particular from 12 to 30 carbon atoms and even better still from 18 to 30 carbon atoms. Preferably, the hydrocarbon-based group is derived from a monofunctional compound. By way of example, the hydrophobic group may be derived from a fatty alcohol such as stearyl alcohol, dodecyl alcohol or decyl alcohol. It may also denote a hydrocarbon-based polymer, such as, for example, polybutadiene.

Metabisulfites

The anhydrous solid dyeing composition according to the present invention may optionally also comprise one or more metabisulfites.

The metabisulfite(s) according to the invention can preferably be chosen from alkali metal or alkaline-earth metal metabisulfites and mixtures thereof, more preferentially from alkali metal metabisulfites and mixtures thereof, and better still from sodium or potassium metabisulfites and mixtures thereof.

Particularly preferably, the metabisulfite is sodium metabisulfite.

The total amount of metabisulfite(s), when they are present in the anhydrous solid dyeing composition according to the invention, preferably ranges from 0.1% to 30% by weight, relative to the total weight of the anhydrous solid dyeing composition.

5 More particularly, the total amount of metabisulfite(s) may range from 0.2% to 20% by weight, more preferentially from 1% to 20% by weight and better still from 3% to 10% by weight, relative to the total weight of the anhydrous solid dyeing composition.

10 More particularly, when the metabisulfite is sodium metabisulfite, the total amount of sodium metabisulfite present in the anhydrous solid dyeing composition according to the invention preferably ranges from 0.1% to 30% by weight, relative to the total weight of the anhydrous solid dyeing composition.

15 More preferentially when the metabisulfite is sodium metabisulfite, the total amount of sodium metabisulfite present in the anhydrous solid dyeing composition according to the invention may range from 0.2% to 20% by weight, better still from 1% to 20% by weight and still from 3% to 10% by weight, relative to the total weight of the anhydrous solid dyeing composition.

20 *The additives*

The anhydrous solid dyeing composition according to the present invention may also optionally comprise one or more additives, different from the compounds of the invention and among which mention may be made of cationic, anionic, non-ionic or amphoteric
25 polymers or mixtures thereof, antidandruff agents, anti-seborrhoea agents, agents for preventing hair loss and/or for promoting hair regrowth, vitamins and provitamins including panthenol, sunscreens, mineral or organic pigments, sequestrants, plasticizers, solubilizers, acidifying agents, mineral or organic thickeners, in particular
30 polymeric thickeners, opacifiers or nacreous agents, antioxidants, hydroxy acids, fragrances, preservatives, pigments and ceramides.

Needless to say, those skilled in the art will take care to select this or these optional additional compound(s) such that the advantageous properties intrinsically associated with the anhydrous

solid dyeing composition in accordance with the invention are not, or are not substantially, adversely affected by the envisaged addition(s).

The above additives may generally be present in an amount, for each of them, of between 0 and 20% by weight relative to the total weight of the anhydrous solid dyeing composition.

Ready-to-use composition

The present invention also relates to a ready-to-use composition comprising an anhydrous solid dyeing composition, as defined above, and a cosmetically acceptable medium. In other words, the ready-to-use composition results from the mixing of an anhydrous solid dyeing composition, as defined previously, and of a cosmetically acceptable medium.

The term “ready-to-use composition” is intended to mean a composition intended to be applied directly to the keratin fibres without being premixed with another composition. The keratin fibres on which said ready-to-use composition is applied may be dry or wet.

The total amount of oxidation base(s) present in the ready-to-use composition according to the present invention preferably ranges from 0.05% to 30% by weight, and more preferentially from 0.1% to 10% by weight, relative to the total weight of the ready-to-use composition.

The total amount of chemical oxidizing agent(s), chosen from alkali metal percarbonates, alkaline-earth metal percarbonates and mixtures thereof, present in the ready-to-use composition according to the invention, preferably ranges from 5% to 50% by weight and more preferentially from 10% to 43% by weight, relative to the total weight of the ready-to-use composition.

The total amount of polymer(s) comprising at least one heterocyclic vinyl monomer, present in the ready-to-use composition according to the invention, preferably ranges from 1% to 40% by weight, more preferentially from 2.5% to 35% by weight, and even better still from 2.5% to 25% by weight, relative to the total weight of the ready-to-use composition.

The total amount of coupler(s), when they are present in the ready-to-use composition according to the invention, preferably ranges from 0.01% to 25% by weight, and more preferentially from 0.1% to 20% by weight, relative to the total weight of the ready-to-use composition.

5

Cosmetically acceptable medium

The term “cosmetically acceptable medium” is intended to mean, according to the present application, a medium that is compatible with keratin fibres, in particular human keratin fibres such as the hair.

10

The cosmetically acceptable medium is constituted of water or of a mixture of water and of one or more organic solvents.

Examples of organic solvents that may be mentioned include linear or branched C₂ to C₄ alkanols, such as ethanol, isopropanol, tert-butanol or n-butanol; glycerol; polyols and polyol ethers, for instance 2-butoxyethanol, propylene glycol, hexylene glycol, dipropylene glycol, propylene glycol monomethyl ether, diethylene glycol monomethyl ether and monoethyl ether, and also aromatic alcohols or ethers, for instance benzyl alcohol or phenoxyethanol, and mixtures thereof.

15

20

Packaging article

A subject of the present invention is also a packaging article comprising:

25

i) an envelope defining at least one cavity, the envelope comprising water-soluble and/or liposoluble fibres, preferably water-soluble fibres; and

ii) an anhydrous solid dyeing composition as defined previously; it being understood that the anhydrous solid dyeing composition is in one of the cavities defined by the envelope i).

30

The term “water-soluble” is intended to mean soluble in water, in particular in a proportion of at least 10 grams per litre of water, preferably at least 20 g/l and better still at least 50 g/l, at a temperature of less than or equal to 35°C.

The term “liposoluble” is intended to mean soluble in a liquid fatty substance as defined below, in particular in a proportion of at least 10 grams per litre of liquid fatty substance, in particular in a plant oil or mineral oil such as liquid petroleum jelly, preferably at least 20 g/l in a liquid fatty substance, better still at least 50 g/l in a fatty substance, at a temperature of less than or equal to 35°C.

The term “temperature of less than or equal to 35°C” is intended to mean a temperature not exceeding 35°C but greater than or equal to 0°C, for example ranging from more than 1 to 35°C, better still from 5 to 30°C and even better still from 10 to 30°C or 10 to 20°C. It is understood that all the temperatures are given at atmospheric pressure.

The packaging article according to the invention is preferably water-soluble or liposoluble at a temperature of less than or equal to 35°C.

The packaging article can comprise one or more cavities, at least one of which contains the anhydrous solid dyeing composition as defined previously.

The packaging article preferably comprises only one cavity.

The envelope may be constituted of a sheet constituted of water-soluble and/or liposoluble fibres, which is folded on itself, or of a first sheet constituted of water-soluble and/or liposoluble fibres and covered with a second sheet also constituted of water-soluble and/or liposoluble fibres. The sheet folded on itself or the two sheets are then assembled hermetically in such a way that the anhydrous solid dyeing composition according to the present invention cannot diffuse to the exterior. The anhydrous solid dyeing composition is thus hermetically enveloped by the envelope i). The anhydrous solid dyeing composition is distinct from the sheet or from the envelope.

Such an envelope is different from water-soluble or liposoluble thin films in which the anhydrous solid dyeing composition would be incorporated in the sheet(s) forming the envelope. Relative to these water-soluble or liposoluble thin films, the envelope according to the invention has the advantage of allowing the incorporation of

constituents that are incompatible therewith, and of being simpler to use since it does not require any premixing or any dissolution of the constituents in a solvent, or any heating to evaporate the solvent. The process for manufacturing the packaging article of the invention is also faster and less expensive than the process for manufacturing thin films.

Furthermore, when the active agents, in this case in particular the oxidation bases and the couplers, are used in dispersion to form a thin film, this may give rise to compatibility problems and mechanical problems (breaking of the film) and may impose limits on the concentration of active agents. In addition, the envelope and the sheets that are useful for the invention have the advantage of allowing wider diversity in the choice of the shape and appearance of the article, since the water-soluble and/or liposoluble sheet(s) may have a variable thickness and a variable density, giving access to a wide variety of shapes and sizes, whereas the thin film is difficult to dry if the thickness is too large, and it is fragile and difficult to manipulate if the size is too large.

Advantageously, the envelope or the sheets are “touch-deformable”, which in particular means that the envelope and the sheets become deformed when they are held and pinched between a user's fingers.

Preferably, the anhydrous solid dyeing composition is present in a cavity generated by at least two sheets constituting the envelope and defining between them a cavity, said sheets preferably comprising water-soluble fibres.

According to a particular embodiment of the invention, at least one of the sheets of the packaging article is constituted exclusively of water-soluble fibres, and more preferentially all the sheets of the packaging article of the invention are constituted exclusively of water-soluble fibres, preferably water-soluble at a temperature of less than or equal to 30°C.

The term “fibre” is intended to mean any object of which the length is greater than its cross section. In other words, it should be

understood as meaning an object of length L and of diameter D such that L is greater and preferably very much greater (i.e. at least three times greater) than D , D being the diameter of the circle in which the cross section of the fibre is inscribed. In particular, the ratio L/D (or aspect ratio) is chosen in the range from 3.5 to 2500, preferably from 5 to 500 and better still from 5 to 150. The cross section of a fibre may have any round, toothed or fluted shape, or alternatively a bean shape, but also multilobate, in particular trilobate or pentalobate, X-shaped, ribbon-shaped, square, triangular, elliptical or the like. The fibres of the invention may or may not be hollow. The fibres used according to the present invention may be of natural, synthetic or even artificial origin. Advantageously, said fibres are of synthetic origin.

A “natural fibre” is by definition a fibre that is naturally present in nature, directly or after mechanical and/or physical treatment. Fibres of animal origin, such as cellulose fibres, in particular extracted from wood, leguminous plants or algae, and rayon fibres, are collated in this category.

The “artificial fibres” are either totally synthetic or derived from natural fibres that have been subjected to one or more chemical treatments in order in particular to improve their mechanical and/or physicochemical properties.

The “synthetic fibres” collate fibres obtained by chemical synthesis and are generally fibres constituted of one or more mono-component or multi-component, composite or non-composite polymers and/or copolymers, which are generally extruded and/or drawn to the desired diameter of the fibre.

Preferably, the fibres of the invention are constituted of one or more water-soluble polymers.

The water-soluble polymer(s) of the invention contain water-soluble units in their backbones. The water-soluble units are obtained from one or more water-soluble monomers.

The term “water-soluble monomer” is intended to mean a monomer of which the solubility in water is greater than or equal to

1% and preferably greater than or equal to 5% at 25°C and at atmospheric pressure (760 mmHg).

Said synthetic water-soluble polymer(s) used in the context of the present invention are advantageously obtained from water-soluble monomers comprising at least one double bond. These monomers may be chosen from cationic, anionic and non-ionic monomers, and mixtures thereof.

As water-soluble monomers that may be used as precursors of the water-soluble units, alone or as a mixture, examples that may be mentioned include the following monomers, which may be in free or salified form:

- (meth)acrylic acid,
- styrenesulfonic acid,
- vinylsulfonic acid and (meth)allylsulfonic acid,
- vinylphosphonic acid,
- N-vinylacetamide and N-methyl-N-vinylacetamide,
- N-vinylformamide and N-methyl-N-vinylformamide,
- N-vinyl lactams comprising a cyclic alkyl group containing from 4 to 9 carbon atoms, such as N-vinylpyrrolidone, N-butyrolactam and N-vinylcaprolactam,
- maleic anhydride,
- itaconic acid,
- vinyl alcohol of formula $\text{CH}_2=\text{CHOH}$,
- vinyl ethers of formula $\text{CH}_2=\text{CHOR}$ in which R is a linear or branched, saturated or unsaturated hydrocarbon-based radical containing from 1 to 6 carbons,
- dimethyldiallylammonium halides (chloride),
- quaternized dimethylaminoethyl methacrylate (DMAEMA),
- (meth)acrylamidopropyltrimethylammonium halides (chloride) (APTAC and MAPTAC),
- methylvinylimidazolium halides (chloride),
- 2-vinylpyridine and 4-vinylpyridine,
- acrylonitrile,
- glycidyl (meth)acrylate,

- vinyl halides (chloride) and vinylidene chloride,
- vinyl monomers of formula (V) below:

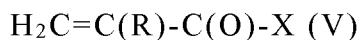

in which:

- 5 - R is chosen from H and (C₁-C₆)alkyl such as methyl, ethyl and propyl;
- X is chosen from:
- alkoxy of -OR' type in which R' is a linear or branched, saturated or unsaturated hydrocarbon-based radical containing from 1 to 6 carbons, optionally substituted with at least one halogen atom (iodine, bromine, chlorine or fluorine); a sulfonic (-SO₃⁻), sulfate (-SO₄⁻), phosphate (-PO₂H₂); hydroxyl (-OH); primary amine (-NH₂); secondary amine (-NHR₆), tertiary amine (-NR₆R₇) or quaternary amine (-N⁺R₆R₇R₈) group with R₆, R₇ and R₈ being, independently of each other, a linear or branched, saturated or unsaturated hydrocarbon-based radical containing 1 to 6 carbon atoms, with the proviso that the sum of the carbon atoms of R' + R₆ + R₇ + R₈ does not exceed 6;
- groups -NH₂, -NHR' and -NR'R'' in which R' and R'' are, independently of each other, linear or branched, saturated or unsaturated hydrocarbon-based radicals containing 1 to 6 carbon atoms, with the proviso that the total number of carbon atoms of R' + R'' does not exceed 6, said R' and R'' being optionally substituted with one halogen atom (iodine, bromine, chlorine or fluorine); a hydroxyl (-OH); sulfonic (-SO₃⁻); sulfate (-SO₄⁻); phosphate (-PO₄H₂); primary amine (-NH₂); secondary amine (-NHR₆), tertiary amine (-NR₆R₇) and/or quaternary amine (-N⁺R₆R₇R₈) group with R₆, R₇ and R₈ being, independently of each other, a linear or branched, saturated or unsaturated hydrocarbon-based radical containing 1 to 6 carbon atoms, with the proviso that the sum of the carbon atoms of R' + R'' + R₆ + R₇ + R₈ does not exceed 6. As compounds corresponding to this formula, examples that may be mentioned include N,N-dimethylacrylamide and N,N-diethylacrylamide; and
- mixtures thereof.

Anionic monomers that may in particular be mentioned include (meth)acrylic acid, acrylamido-2-methylpropanesulfonic acid, itaconic acid and alkali metal, alkaline-earth metal or ammonium salts thereof or salts thereof derived from an organic amine such as an alkanolamine.

Non-ionic monomers that may in particular be mentioned include (meth)acrylamide, N-vinylformamide, N-vinylacetamide, hydroxypropyl (meth)acrylate and the vinyl alcohol of formula $\text{CH}_2=\text{CHOH}$.

The cationic monomers are preferably chosen from quaternary ammonium salts derived from a diallylamine and those corresponding to formula (VI) below:



in which:

- R_1 represents a hydrogen atom or a methyl group,
- R_2 and R_3 , which may be identical or different, represent a hydrogen atom or a linear or branched C_1 to C_4 alkyl group,
- R_4 represents a hydrogen atom or a linear or branched C_1 to C_4 alkyl group or an aryl group,
- D represents the following divalent unit: $\text{-(Y)}_n\text{-(A)-}$ in which:
 - Y represents an amide function, an ester (O-C(O) or C(O)-O), a urethane or a urea,
 - A represents a linear or branched, cyclic or acyclic C_1 to C_{10} alkylene group, which may be substituted or interrupted with a divalent aromatic or heteroaromatic group. The alkylene groups may be interrupted with an oxygen atom, a nitrogen atom, a sulfur atom or a phosphorus atom; the alkylene may be interrupted with a ketone function, an amide, an ester (O-C(O) or C(O)-O), a urethane or a urea,
 - n is an integer ranging from 0 to 1,
- X^- represents an anionic counterion, for instance a chloride or a sulfate.

Examples of water-soluble cationic monomers that may in particular be mentioned include the following compounds, and also

salts thereof: dimethylaminoethyl,
 (meth)acryloyloxyethyltrimethylammonium,
 (meth)acryloyloxyethyltrimethylammonium, N-
 [dimethylaminopropyl](meth)acrylamide,
 5 (meth)acrylamidopropyltrimethylammonium,
 (meth)acrylamidopropyltrimethylammonium,
 dimethylaminohydroxypropyl,
 (meth)acryloyloxyhydroxypropyltrimethylammonium,
 (meth)acryloyloxyhydroxypropyltrimethylammonium and
 10 dimethyldiallylammonium (meth)acrylate.

Preferably, the polymer of use according to the invention is polymerized from at least one cationic monomer as defined above.

Preferably, the polymers are polymerized from the following monomers comprising at least one double bond:

- 15 - 0 to 30 mol% of acrylic acid,
 - 0 to 95.5 mol% of acrylamide, and
 - 0.5 mol% to 100 mol% of at least one cationic monomer represented in formula (VI) as defined above.

As polymers that are particularly preferred in the invention, 20 mention may be made in particular of those polymerized from:

- 10% of acryloyloxyethyltrimethylammonium chloride and 90% of acrylamide,
 - 30% of acryloyloxytrimethylammonium chloride, 50% of acryloyloxyethyltrimethylammonium chloride and 20% of
 25 acrylamide,
 - 10% of acryloyloxyethyltrimethylammonium chloride and 90% of acrylamide,
 - 30% of diallyldimethylammonium chloride and 70% of acrylamide,
 or
 30 - 30% of acrylic acid and 70% of acrylamide.

According to a particular embodiment, the polymers are polymerized from a cationic monomer and acrylic acid, the number of moles of the cationic monomer being greater than the number of moles of acrylic acid.

As water-soluble polymers derived from natural products, mention may be made of polysaccharides, i.e. polymers bearing sugar units.

5 The term "sugar unit" is intended to mean a unit resulting from a carbohydrate of formula $C_n(H_2O)_{n-1}$ or $(CH_2O)_n$, which can be optionally modified by substitution and/or by oxidation and/or by dehydration. The sugar units that may be included in the composition of the polymers of the invention are preferably derived from the following sugars: glucose, galactose, arabinose, rhamnose, mannose,
10 xylose, fucose, fructose, anhydrogalactose, galacturonic acid, glucuronic acid, mannuronic acid, galactose sulfate or anhydrogalactose sulfate.

The polymers having a sugar unit or sugar units according to the invention can be of natural or synthetic origin. They can be non-
15 ionic, anionic, amphoteric or cationic. The base units of the polymers having a sugar unit of the invention can be mono- or disaccharides.

Mention may in particular be made, as polymers capable of being employed, of the following native gums, and also their derivatives:

20 a) tree or shrub exudates, including:

- gum arabic (branched polymer of galactose, arabinose, rhamnose and glucuronic acid);
- ghatti gum (polymer derived from arabinose, galactose, mannose, xylose and glucuronic acid);
- 25 - karaya gum (polymer derived from galacturonic acid, galactose, rhamnose and glucuronic acid);
- gum tragacanth (polymer of galacturonic acid, galactose, fucose, xylose and arabinose);

b) gums resulting from algae, including:

- 30 - agar (polymer derived from galactose and anhydrogalactose);
- alginates (polymers of mannuronic acid and of glucuronic acid);
- carrageenans and furcellerans (polymers of galactose sulfate and of anhydrogalactose sulfate);

c) gums resulting from seeds or tubers, including:

- guar gum (polymer of mannose and galactose);
- locust bean gum (polymer of mannose and galactose);
- fenugreek gum (polymer of mannose and galactose);
- tamarind gum (polymer of galactose, xylose and glucose);
- 5 - konjac gum (polymer of glucose and mannose) in which the main constituent is glucomannan, a polysaccharide of high molecular weight ($500\ 000 < M_{\text{glucomannan}} < 2\ 000\ 000$) composed of D-mannose and D-glucose units with a branch every 50 or 60 units approximately;
- d) microbial gums, including:
- 10 - xanthan gum (polymer of glucose, mannose acetate, mannose/pyruvic acid and glucuronic acid);
- gellan gum (polymer of partially acylated glucose, rhamnose and glucuronic acid);
- scleroglucan gum (glucose polymer);
- 15 - biosaccharide gum (polymer of galacturonic acid, fucose and D-galactose), for example the product sold under the name Fucogel 1.5P from Solabia (polysaccharide rich in fucose (20%) at 1.1% in water and stabilized (1.5% phenoxyethanol));
- e) plant extracts, including:
- 20 - cellulose (glucose polymer);
- starch (glucose polymer);
- inulin (polymer of fructose and glucose).

These polymers can be physically or chemically modified. Mention may in particular be made, as physical treatment, of the
25 temperature. Mention may be made, as chemical treatments, of esterification, etherification, amidation or oxidation reactions. These treatments make it possible to result in polymers which can be non-ionic, anionic, cationic or amphoteric.

Preferably, these chemical or physical treatments are applied to
30 guar gums, locust bean gums, starches and celluloses.

The non-ionic guar gums that may be used according to the invention may be modified with C₁ to C₆ hydroxyalkyl groups. Mention may be made, among the hydroxyalkyl groups, of the

hydroxymethyl, hydroxyethyl, hydroxypropyl and hydroxybutyl groups.

5 These guar gums are well known in the prior art and may be prepared, for example, by reacting the corresponding alkene oxides, for instance, propylene oxides, with the guar gum so as to obtain a guar gum modified with hydroxypropyl groups.

10 The degree of hydroxyalkylation preferably varies from 0.4 to 1.2 and corresponds to the number of alkylene oxide molecules consumed by the number of free hydroxyl functional groups present on the guar gum.

Such non-ionic guar gums optionally modified with hydroxyalkyl groups are sold, for example, under the trade names Jaguar HP8, Jaguar HP60 and Jaguar HP120 by the company Rhodia Chimie.

15 The guar gums modified with cationic groups which can more particularly be used according to the invention are guar gums comprising trialkylammonium cationic groups. Preferably, from 2% to 30% of the number of the hydroxyl functional groups of these guar gums carry trialkylammonium cationic groups. More preferably still, 20 from 5% to 20% of the number of the hydroxyl functional groups of these guar gums are branched with trialkylammonium cationic groups. Mention may very particularly be made, among these trialkylammonium groups, of the trimethylammonium and triethylammonium groups. More preferably still, these groups 25 represent from 5% to 20% by weight, relative to the total weight of the modified guar gum.

According to the invention, use may be made of guar gums modified with 2,3-epoxypropyltrimethylammonium chloride.

30 These guar gums modified with cationic groups are products already known per se and are, for example, described in Patents US 3 589 578 and US 4 031 307. Such products are moreover sold especially under the trade names Jaguar C13 S, Jaguar C 15 and Jaguar C 17 by the company Rhodia Chimie.

Use may be made, as modified locust bean gum, of the cationic locust bean gum containing hydroxypropyltrimonium groups, such as Catinal CLB 200 provided by Toho.

5 The starch molecules used in the present invention can originate from any plant starch source, in particular cereals and tubers; more particularly, they can be starches from maize, rice, cassava, barley, potato, wheat, sorghum, pea, oat or tapioca. It is also possible to use the hydrolyzates of the starches mentioned above. The starch is preferably derived from potato.

10 The starches can be chemically or physically modified, in particular by one or more of the following reactions: pregelatinization, oxidation, crosslinking, esterification, etherification, amidation or heat treatments.

15 More particularly, these reactions may be performed in the following manner:

- pregelatinization by splitting the starch granules (for example drying and cooking in a drying drum);
- oxidation with strong oxidizing agents, resulting in the introduction of carboxyl groups into the starch molecule and in the depolymerization of the starch molecule (for example by treating an aqueous starch solution with sodium hypochlorite);
- crosslinking with functional agents capable of reacting with the hydroxyl groups of the starch molecules, which will thus be bonded together (for example with glyceryl and/or phosphate groups);
- 25 - esterification in alkaline medium for the grafting of functional groups, especially C₁-C₆ acyl (acetyl), C₁-C₆ hydroxyalkyl (hydroxyethyl or hydroxypropyl), carboxymethyl or octenylsuccinic.

30 It is possible in particular to obtain, by crosslinking with phosphorus compounds, monostarch phosphates (of the type St-O-PO-(OX)₂), distarch phosphates (of the type St-O-PO-(OX)-O-St) or even tristarch phosphates (of the type St-O-PO-(O-St)₂) or mixtures thereof, with St meaning starch and X denoting in particular alkali metals (for example sodium or potassium), alkaline-earth metals (for example calcium or magnesium), aqueous-ammonia salts, amine salts, such as

those of monoethanolamine, diethanolamine, triethanolamine or 3-amino-1,2-propanediol, or ammonium salts resulting from basic amino acids, such as lysine, arginine, sarcosine, ornithine or citrulline.

5 The phosphorus compounds can, for example, be sodium tripolyphosphate, sodium orthophosphate, phosphorus oxychloride or sodium trimetaphosphate.

10 Distarch phosphates or compounds rich in distarch phosphate will preferentially be used, for instance the product sold under the references Prejel VA-70-T AGGL (gelatinized hydroxypropyl cassava distarch phosphate), Prejel TK1 (gelatinized cassava distarch phosphate) and Prejel 200 (gelatinized acetyl cassava distarch phosphate) by the company Avebe, or Structure Zea from National Starch (gelatinized corn distarch phosphate).

15 A preferred starch is a starch which has undergone at least one chemical modification, such as at least one esterification.

20 According to the invention, use may also be made of amphoteric starches comprising one or more anionic groups and one or more cationic groups. The anionic and cationic groups can be bonded to the same reactive site of the starch molecule or to different reactive sites; they are preferably bonded to the same reactive site. The anionic groups can be of carboxylic, phosphate or sulfate type, preferably of carboxylic type. The cationic groups may be of primary, secondary, tertiary or quaternary amine type.

25 The amphoteric starches are in particular chosen from the compounds having the following formulae:

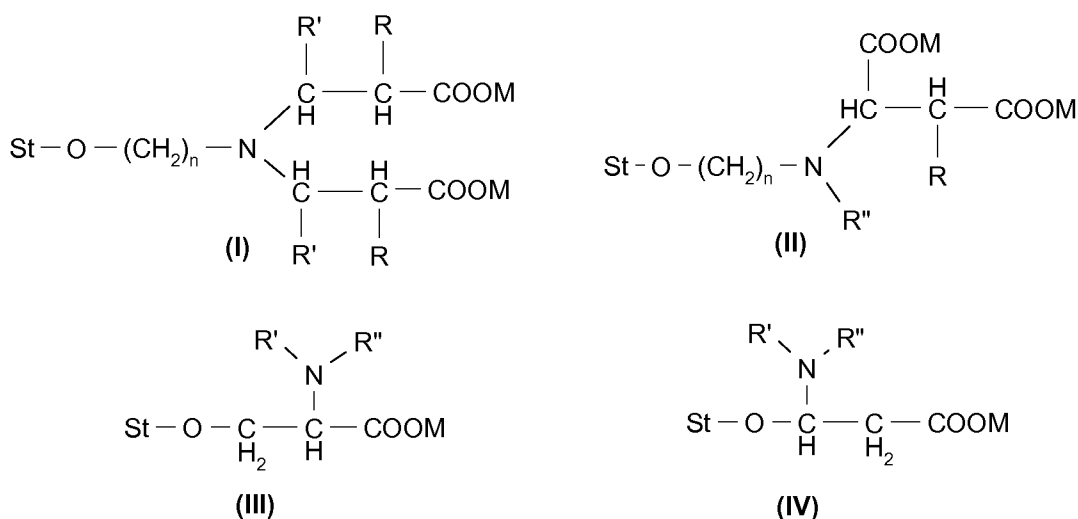

in which:

- St-O represents a starch molecule;
- 5 • R, which may be identical or different, represents a hydrogen atom or a methyl radical;
- R', which may be identical or different, represents a hydrogen atom, a methyl radical or a group -C(O)-OH;
- n is an integer equal to 2 or 3;
- 10 • M, which may be identical or different, denotes a hydrogen atom, an alkali metal or alkaline-earth metal such as Na, K or Li, a quaternary ammonium NH₄, or an organic amine;
- R'' represents a hydrogen atom or a C₁ to C₁₈ alkyl radical.

15 These compounds are especially described in US 5 455 340 and US 4 017 460.

Use is in particular made of the starches of formula (II) or (III); and preferably starches modified with 2-chloroethylaminodipropionic acid, that is to say the starches of formula (II) or (III) in which R, R', R'' and M represent a hydrogen atom and n is equal to 2. The preferred amphoteric starch is a starch 20 chloroethylamidodipropionate.

The celluloses and cellulose derivatives can be anionic, cationic, amphoteric or non-ionic.

Among these derivatives, cellulose ethers, cellulose esters and cellulose ester ethers are distinguished.

5 Mention may be made, among the cellulose esters, of inorganic cellulose esters (cellulose nitrates, sulfates or phosphates), organic cellulose esters (cellulose monoacetates, triacetates, amidopropionates, acetate butyrates, acetate propionates or acetate trimellitates), and mixed organic/inorganic cellulose esters, such as cellulose acetate butyrate sulfates and cellulose acetate propionate sulfates.

10 Mention may be made, among the cellulose ester ethers, of hydroxypropyl methylcellulose phthalates and ethylcellulose sulfates.

 Mention may be made, among the non-ionic cellulose ethers, of alkylcelluloses, such as methylcelluloses and ethylcelluloses (for example Ethocel Standard 100 Premium from Dow Chemical);
15 hydroxyalkylcelluloses, such as hydroxymethylcelluloses and hydroxyethylcelluloses (for example Natrosol 250 HHR provided by Aqualon) and hydroxypropylcelluloses (for example Klucel EF from Aqualon); and mixed hydroxyalkyl alkylcelluloses, such as hydroxypropyl methylcelluloses (for example Methocel E4M from
20 Dow Chemical), hydroxyethyl methylcelluloses, hydroxyethyl ethylcelluloses (for example Bermocoll E 481 FQ from Akzo Nobel) and hydroxybutyl methylcelluloses.

 Among the anionic cellulose ethers, mention may be made of carboxyalkyl celluloses and salts thereof. Examples that may be
25 mentioned include carboxymethyl celluloses, carboxymethyl methyl celluloses (for example Blanose 7M from the company Aqualon) and carboxymethyl hydroxyethyl celluloses, and also the sodium salts thereof.

 Among the cationic cellulose ethers, mention may be made of
30 crosslinked or non-crosslinked quaternized hydroxyethylcelluloses. The quaternizing agent can in particular be diallyldimethylammonium chloride (for example Celquat L200 from National Starch). Mention may be made, as other cationic cellulose ether, of

hydroxyethylcellulose hydroxypropyltrimethylammonium chloride (for example Ucare polymer JR 400 from Amerchol).

Among the associative polymers bearing a sugar unit or sugar units, mention may be made of celluloses or derivatives thereof, modified with groups comprising at least one fatty chain, such as alkyl, arylalkyl or alkylaryl groups or mixtures thereof in which the alkyl groups are of C₈-C₂₂; non-ionic alkylhydroxyethylcelluloses such as the products Natrosol Plus Grade 330 CS and Polysurf 67 (C₁₆ alkyl) sold by the company Aqualon; quaternized alkyhydroxyethylcelluloses (cationic), such as the products Quatrisoft LM 200, Quatrisoft LM-X 529-18-A, Quatrisoft LM-X 529-18-B (C₁₂ alkyl) and Quatrisoft LM-X 529-8 (C₁₈ alkyl) sold by the company Amerchol, the products Crodacel QM and Crodacel QL (C₁₂ alkyl) and Crodacel QS (C₁₈ alkyl) sold by the company Croda, and the product Softcat SL 100 sold by the company Amerchol; non-ionic nonoxynylhydroxyethylcelluloses such as the product Amercell HM-1500 sold by the company Amerchol; non-ionic alkylcelluloses such as the product Bermocoll EHM 100 sold by the company Berol Nobel.

As associative polymers bearing a sugar unit or sugar units derived from guar, mention may be made of hydroxypropyl guar modified with a fatty chain, such as the product Esaflor HM 22 (modified with a C₂₂ alkyl chain) sold by the company Lamberti; the product Miracare XC 95-3 (modified with a C₁₄ alkyl chain) and the product RE 205-146 (modified with a C₂₀ alkyl chain) sold by Rhodia Chimie.

The polymer(s) having a sugar unit or sugar units of the invention are preferably chosen from guar gums, locust bean gums, xanthan gums, starches and celluloses, in their modified form (derivatives) or unmodified form.

Preferably, the polymers bearing a sugar unit or sugar units according to the invention are non-ionic.

More preferably, the polymer(s) bearing a sugar unit or sugar units of the invention are chosen from modified non-ionic guar gums, especially modified with C₁ to C₆ hydroxyalkyl groups.

The polymers described above more particularly have a weight-average molecular weight of greater than 1 000 000 and preferably between 1 000 000 and 50 000 000. The molecular weight is determined by the RSV (Reduced Specific Viscosity) method as defined in "Principles of Polymer Chemistry" Cornell University Press, Ithaca, NY 1953 Chapter VII "Determination of molecular weight" pp. 266-316.

The fibres may be spun, carded or twisted. Advantageously, the fibres used in the context of the present invention are spun. The mean diameter of the fibres used according to the present invention, which may be identical or different, is less than 500 μm . Advantageously, such a diameter is less than 200 μm , preferably less than 100 μm or even less than 50 μm .

Mention may be made more particularly of water-soluble fibres that include fibres based on polyvinyl alcohol, fibres of polysaccharides such as glucomannans, starches or celluloses such as carboxymethylcelluloses, polyalginic acid fibres, polylactic acid fibres and polyalkylene oxide fibres, and also mixtures thereof. More preferentially, the water-soluble fibre(s) used in the invention are chosen from PVA-based fibres.

The fibres of the envelope or of the sheets are generally entangled. As indicated above, the term "envelope or sheet comprising water-soluble fibres" is intended to mean an envelope or sheets which may be constituted entirely of water-soluble fibres or a sheet which may comprise both water-soluble fibres and fibres that are insoluble in water at a temperature of less than or equal to 35°C, the soluble fibres necessarily being in a larger amount than the insoluble fibres. The sheet of fibres should comprise at least 60% by weight, preferably at least 70% by weight and better still at least 80% by weight of soluble fibres relative to the total weight of fibres. It may thus comprise, for example, more than 95% by weight, or even more than 99% by weight and even 100% by weight of water-soluble fibres relative to the total weight of fibres in the envelope or the sheets.

When the sheet of fibres contains insoluble fibres, the latter fibres may be made of any material usually used as insoluble fibres; they may be, for example, silk fibre, cotton fibre, wool fibre, flax fibre, polyamide (Nylon[®]) fibre, polylactic acid fibre, modified cellulose (rayon, viscose or rayon acetate) fibre, poly-p-phenyleneterephthalamide fibre, in particular Kevlar[®] fibre, polyolefin fibre and in particular polyethylene or polypropylene fibre, glass fibre, silica fibre, aramid fibre, carbon fibre, in particular in graphite form, Teflon[®] fibre, insoluble collagen fibre, polyester fibre, polyvinyl or polyvinylidene chloride fibre, polyethylene terephthalate fibre, and fibres formed from a mixture of the compounds mentioned above, for instance polyamide/polyester or viscose/polyester fibres.

In addition, the envelope and the sheets of the invention may be woven or nonwoven.

According to a particular embodiment, the envelope and the sheets of the invention are woven. In the context of the present invention, a “woven” material results from an organized assembly of fibres, in particular of water-soluble polymeric fibres, and more particularly of an intercrossing, in the same plane, of said fibres, arranged in the warp direction and of fibres arranged, perpendicular to the warp fibres, in the weft direction. The binding obtained between these warp and weft fibres is defined by a weave.

Such a woven material results from an operation directed towards assembling the fibres in an organized manner such as weaving per se, but may also result from knitting.

More particularly, the two layers or sheets comprising the woven polymeric water-soluble fibres that constitute the envelope of the packaging article of the invention do not comprise any other additional layer superposed thereon.

According to another particularly advantageous mode of the invention, the envelope and the sheets are nonwoven.

For the purposes of the present invention, the expression “nonwoven” is intended to mean a substrate comprising fibres, in particular water-soluble polymeric fibres, in which substrate the

individual fibres are arranged in a disordered manner in a structure in the form of a sheet and which are neither woven nor knitted. The fibres of the nonwoven are generally bonded together, either under the effect of a mechanical action (for example needle punching, air jet, water jet, etc.), or under the effect of a thermal action, or by addition of a binder.

Such a nonwoven is, for example, defined by standard ISO 9092 as a web or a sheet of directionally or randomly orientated fibres, bonded by friction and/or cohesion and/or adhesion, excluding paper and products obtained by weaving, knitting, tufting or stitching incorporating binding yarns or filaments.

A nonwoven differs from a paper by virtue of the length of the fibres used. In paper, the fibres are shorter. However, there are nonwovens based on cellulose fibre, which are manufactured by a wet-laid process and that have short fibres as in paper. The difference between a nonwoven and a paper is generally the absence of hydrogen bonding between the fibres in a nonwoven.

Very preferentially, the fibres used in the context of the present invention are chosen from synthetic fibres such as PVA fibres. In particular, the envelope and sheets of the invention are nonwovens, and preferentially made of nonwoven PVA fibres.

To produce the nonwoven water-soluble sheet(s) of the envelope of the packaging article, use is preferably made of PVA fibres that are soluble in water at a temperature of less than or equal to 35°C, for instance the fibres sold by the Japanese company Kuraray under the name Kuralon K-II, and particularly the grade WN2 which is soluble at and above 20°C. These fibres are described in document EP-A-636 716 which teaches the manufacture of PVA fibres that are soluble in water at temperatures not exceeding 100°C, by spinning and drawing the polyvinyl alcohol polymer in dry or wet form in the presence of solvents participating in the dissolution and solidification of the fibre. The fibre thus obtained may lead to the production of woven or nonwoven substrates. According to a particular mode of the invention, the PVA fibres of the examples of EP-A-636 716 are used,

in particular Example 2 and Comparative Example 1: commercial product Solvron SS.

5 These fibres may also be prepared from a solution to be spun, by dissolving a water-soluble PVA-based polymer in a first organic solvent, spinning the solution in a second organic solvent to obtain solidified filaments and wet-drawing of the filaments from which the first solvent is removed, and which are then dried and subjected to a heat treatment. The cross section of these fibres may be substantially circular. These fibres have a tensile strength of at least 2.7 g/dtex (3 g/d). Patent application EP-A-0 636 716 describes such PVA-based water-soluble fibres and the process for manufacturing them. For example, the fibres may also be formed by extrusion and deposited on a conveyor to form a sheet of fibres which is then consolidated via a standard fibre bonding technique, for instance needle punching, hot-bonding, calendaring or air-through bonding, in which technique the water-soluble sheet passes through a tunnel in which hot air is blown, or hydroentanglement directed towards bonding the fibres via the action of fine jets of water at very high pressure, which cannot be applied to fibres of which the dissolution temperature is too low pressure.

20 As has been seen previously, the invention is not limited to the use of PVA, and use may also be made of fibres made of other water-soluble materials, provided that these materials dissolve in water having the desired temperature, for example the polysaccharide fibres sold under the name Lysorb by the company Lysac Technologies, Inc. or other fibres based on polysaccharide polymers such as glucomannans or starch.

The sheets of the envelope may comprise a mixture of different fibres that are soluble in water at various temperatures (up to 35°C).

30 The fibres may be composites, and they may comprise, for example, a core and a sheath not having the same nature, for example formed from different grades of PVA.

According to a particular embodiment of the invention, the sheet(s) of the envelope have a nonwoven comprising water-soluble

fibres, alone or as a mixture with insoluble fibres as indicated above, with not more than 40% by weight of insoluble fibres relative to the total weight of the fibres constituting the sheet. Preferably, the nonwoven is constituted essentially of water-soluble fibres, i.e. it does not contain any insoluble fibres.

The envelope may have any shape that is suitable for the intended use, for example a rectangular, circular or oval shape, and it preferably has dimensions that enable it to be held between at least two fingers. Thus, the envelope or the sheets may have, for example, an ovoid shape from about 2 to 10 cm long and from about 0.5 to 4 cm wide, or a circular disc shape from about 2 to 10 cm in diameter, or a square shape with a side length from about 5 to 15 cm, or a rectangular shape with a length from about 5 to 25 cm, it being understood that it may have any other shape and size that are suitable for the desired use.

Advantageously, the envelope and the sheets have a low thickness, the sheets possibly being constituted of several layers. Preferably, the thickness of the envelope and of the sheets ranges from 3% to 99.9% of its other dimensions. This thickness is in particular less than 100 mm. The envelope and the sheets are thus substantially flat, thin slices.

The surface delimiting the cavity(ies) has an area generally less than 625 cm², for example between 400 cm² and 0.025 cm².

Use may be made, for example, of an envelope and sheets as defined in French patent application No. FR 1 261 120 filed on 22 November 2012.

The packaging article according to the present invention may comprise one or more water-soluble nonwoven sheets and envelope.

Preferentially, the amount of envelope present in the packaging article according to the invention is between 0.5% and 20% by weight relative to the total weight of said article, advantageously between 1.0% and 10%, particularly between 2% and 5% and more particularly 3% by weight relative to the total weight of the packaging article.

The packaging article that can contain the composition according to the invention can be illustrated by Figures 1a)-1e).

Figure 1a) is a cross section of a particular embodiment of the packaging article comprising the envelope i) constituted of two sheets, which are preferably water-soluble, 11 and 12, bonded together in a peripheral region 14.

5 Preferably, the two sheets are joined by any suitable fixing means, preferably gluing, welding, in particular heat-welding, and in particular by entanglement.

The first sheet 11 also has a free central region D arranged facing a free central region D of the second sheet 12. These two
10 central regions delimit a central cavity; said cavity contains an anhydrous solid dyeing composition as defined previously 13.

The sheets 11 and 12 have a closed outer perimeter 15. The shape of the outer perimeter 15 is rounded, preferably circular or elliptical, or polygonal, preferably square, rectangular or triangular,
15 and more preferentially circular.

Figure 1b) shows a top view of the packaging article as described in Figure 1a), in which part D corresponds to the cavity or “*central region*” in which is found the anhydrous solid dyeing composition 13, and d corresponds to the peripheral region
20 hermetically joining the two sheets 11 and 12.

Figure 1c) shows a cross section of a particular embodiment of the packaging article, comprising an envelope constituted of two sheets 11 and 12, which are preferably water-soluble, and comprising an additional sheet 16, which is preferably water-soluble, and
25 optionally other additional sheets 17, which are preferably water-soluble, which define several cavities in which are housed the ingredients such as the anhydrous solid dyeing composition 13 as defined previously, one or more additional chemical oxidizing agents, which are different from the chemical oxidizing agents (b), as defined
30 previously, and/or one or more additives, as defined previously, 19, and/or one or more additives which are different from those introduced into the other cavities 20, as defined previously.

The first sheet 11 has a thickness smaller than its other dimensions, for example less than 10% of its maximum transverse dimension $D+2d$.

5 The thickness of the first sheet 11 is, for example, less than 10 mm and in particular between 0.1 mm and 3 mm. Its maximum transverse dimension $D+d$ is, for example, less than 100 mm, and is in particular inclusively between 10 mm and 60 mm.

10 The first sheet 11 thus forms a layer, for example made of nonwoven, which itself may be constituted of several layers of nonwoven that are consolidated together.

The second sheet 12 also has a closed outer perimeter 15. The outer perimeter 15 of the first sheet 11 has a shape identical to the outer perimeter 15 of the second sheet 12.

15 The second sheet 12 has a thickness smaller than its other dimensions, for example less than 10% of its maximum transverse dimension $D+2d$.

20 The thickness of the second sheet 12, which is preferably water-soluble, is, for example, less than 10 mm and in particular between 0.1 mm and 3 mm. Its maximum transverse dimension $D+2d$ is less than 100 mm, and is in particular between 10 mm and 60 mm.

The thickness is advantageously measured according to the standard EDANA WSP 120.1(5).

The second sheet 12 is advantageously a nonwoven.

25 The first sheet 11 and the second sheet 12, which may be identical or of different thicknesses, densities and/or compositions, are preferably nonwovens that are water-soluble at a temperature of less than or equal to 35°C. The sheets and nonwoven envelope are soluble in an aqueous solution, such as water. The nonwoven sheets and envelope are preferentially made of PVA.

30 As a variant, the second sheet may be formed by the first sheet folded on itself 11' shown in Figure 1d) in cross section and Figure 1e) in top view. The sheet is folded on itself along the folding axis, which defines a cavity in which is found the anhydrous solid dyeing composition 13', and optionally one or more additional chemical

oxidizing agents which are different from the chemical oxidizing agents (b), as defined previously, and/or one or more additives, as defined previously, 19', optionally separated by one or more water-soluble sheets 16'. The sheet 11', once filled with the ingredients 19' and with the water-soluble sheet(s) 16', is folded along the axis e, forming a folding zone 15' and then joined at a peripheral region 14, the shaded part of Figure e), preferably via any suitable fixing means such as gluing, welding, in particular heat-welding, and in particular by entanglement. The thickness of the water-soluble sheet 11' and the transverse dimensions satisfy the same criteria as those defined for the sheet 11 or 12 of Figure 1b).

The fibres forming the first sheet 11 or 11' and the second sheet 12, and the additional sheets 16, 16' and 17, are preferably water-soluble, i.e. they are constituted of water-soluble fibres. These fibres are, for example, nonwoven water-soluble fibres such as PVA fibres, polysaccharide fibres such as glucomannans or starches, or any other polymer or compound that is capable of forming water-soluble fibres or yarns, obtained, for example, by extrusion.

The sheets 11, 11' and 12 and the optional additional sheets 16, 16' and 17, which are preferably made of nonwoven, generally have a basis weight of less than or equal to 60 g/m², or even less than or equal to 50 g/m² and even better still less than or equal to 45 g/m². In one variant, the basis weight of at least one layer may be greater than 60 g/m².

The packaging articles comprising water-soluble fibres according to the invention are preferably soluble in water or in an aqueous composition with a dissolution time of the packaging article preferably of not more than one hour.

Process for preparing the packaging article

The envelope i) delimits or defines a cavity which is filled with an anhydrous solid dyeing composition, as defined previously, the article is then closed by folding the envelope i) on itself with its contents, followed by assembly at its periphery, for example by gluing or welding, preferably by heat-welding, or alternatively, if the article

contains an envelope made up of two sheets, the anhydrous solid dyeing composition ii) and optionally one or more additional chemical oxidizing agents, preferably anhydrous solid chemical oxidizing agents, which are different from the chemical oxidizing agents (b) and/or one or more additives iii) are placed on the first sheet, and the article is closed by means of a second sheet which covers the ingredients ii) and iii) placed on the first sheet and which is assembled, for example, by gluing or welding at its periphery, preferably by heat-welding at its periphery, so as to obtain a hermetic article, which does not allow the ingredients ii) and iii) contained in said article to pass into the atmosphere.

When the envelope and the sheets comprise several water-soluble sheets of nonwovens, these nonwovens may be assembled in particular by heat-welding at their periphery. Preferably, the heat-welding is performed with entanglement of the fibres of the parts of the envelope to be welded.

Dyeing method

The present invention also relates to a process for dyeing keratin fibres, in particular human keratin fibres such as the hair, comprising the following successive steps:

- applying to said keratin fibres a ready-to-use composition as defined previously, that is to say resulting from the mixing of an anhydrous solid dyeing composition, as defined previously, and of a cosmetically acceptable medium,
- leaving the ready-to-use composition on said keratin fibres,
- rinsing said keratin fibres, and
- optionally shampooing said keratin fibres, rinsing them and drying them.

The present invention also relates to a process for dyeing keratin fibres, in particular human keratin fibres such as the hair, comprising the following successive steps:

- mixing a packaging article, as defined previously, with a composition that is capable of dissolving the envelope of said packaging article,
- applying the resulting composition to said keratin fibres,
- 5 - leaving said resulting composition on said keratin fibres,
- rinsing said keratin fibres, and
- optionally shampooing said keratin fibres, rinsing them and drying them.

10 It is understood that the composition capable of dissolving the envelope depends on the nature of the envelope. In other words, the composition capable of dissolving the envelope is water or an aqueous composition, when the packaging article contains predominantly or only a hydrophilic envelope. In addition, the composition capable of dissolving the envelope is an organic anhydrous composition or an
15 aqueous composition comprising at least one liquid fatty substance or at least one organic solvent other than the liquid fatty substances, such as lower monoalcohols, for example ethanol, or such as polyols, for example propylene glycol or glycerol, when the packaging article contains predominantly or only a lipophilic envelope.

20 Thus, the aqueous composition may simply be water. The aqueous composition may optionally comprise at least one polar solvent. Among the polar solvents that may be used in this composition, mention may be made of organic compounds that are liquid at ambient temperature (25°C) and at least partially water-
25 miscible.

Examples that may be mentioned more particularly include alkanols such as ethyl alcohol, isopropyl alcohol, aromatic alcohols such as benzyl alcohol and phenylethyl alcohol, or polyols or polyol
30 ethers, for instance ethylene glycol monomethyl, monoethyl or monobutyl ether, propylene glycol or ethers thereof, for instance propylene glycol monomethyl ether, butylene glycol, dipropylene glycol, and also diethylene glycol alkyl ethers, for instance diethylene glycol monoethyl ether or monobutyl ether.

More particularly, if one or more solvents are present, their respective content in the aqueous composition ranges from 0.5% to 20% by weight and preferably from 2% to 10% by weight relative to the weight of said aqueous composition.

5 The dilution ratio (expressed by weight) between one or more packaging articles, as defined previously, and the composition capable of dissolving the packaging article(s) is preferably between 10/90 and 90/10, and more preferentially between 10/90 and 50/50. Even better still, this dilution ratio is 20/80.

10 When the composition capable of dissolving the article is an aqueous hydrogen peroxide solution, it preferably has a pH of less than 7. The acidic pH ensures the stability of the hydrogen peroxide in the composition. It may be obtained using acidifying agents, for instance hydrochloric acid, acetic acid, etidronic acid, phosphoric acid, lactic acid or boric acid, and it may be conventionally adjusted by adding either basifying agents, for instance aqueous ammonia, monoethanolamine, diethanolamine, triethanolamine, isopropanolamine, 1,3-diaminopropane, an alkali metal or ammonium (bi)carbonate, an organic carbonate such as guanidine carbonate, or an alkali metal hydroxide, all these compounds, needless to say, possibly being taken alone or as a mixture.

15 The pH of the ready-to-use composition resulting from the mixing of a packaging article, as defined previously, with a composition capable of dissolving the envelope of the packaging article is preferably between 7 and 12 and more preferentially between 7.5 and 11.

20 In particular, the ready-to-use composition used in the dyeing process according to the invention is applied to dry or wet keratin fibres.

30 The ready-to-use composition is advantageously left to stand on the keratin fibres for a time ranging from 1 minute to 1 hour and more preferentially for a time ranging from 5 to 45 minutes.

The keratin fibres are then rinsed with water. They may optionally be washed with a shampoo, followed by rinsing with water, before being dried or left to dry.

5 The working temperature of the dyeing process according to the invention is preferably between ambient temperature (25°C) and 80°C and more preferentially between ambient temperature and 60°C.

Use

10 The present invention also relates to the use of an anhydrous solid dyeing composition, as defined previously, for dyeing keratin fibres, and in particular human keratin fibres such as the hair.

A subject of the present invention is also the use of a packaging article, as defined previously, for dyeing keratin fibres, and in particular human keratin fibres such as the hair.

15 The examples that follow serve to illustrate the invention without, however, being limiting in nature.

EXAMPLES

20 In the examples which follow, all the amounts are shown as percentage by weight of active material, relative to the total weight of the composition.

A. Example 1

25

I. Preparation of the compositions

30 The dyeing composition (A), according to the invention, and the comparative dyeing compositions (A1) and (A2) that follow, in anhydrous powder form, were prepared from the ingredients of which the contents are indicated in the tables below (% in g of active material).

	A invention	A1 comparative	A2 comparative
2,5-Toluenediamine sulfate	2	2	2
2,4-Diaminophenoxyethanol, HCl	0.029	0.029	0.029
Resorcinol	1	1	1
m-Aminophenol	0.2	0.2	0.2
Sodium percarbonate	42.2	42.2	42.2
Ammonium sulfate	3.6	3.6	3.6
Hydroxypropyl starch phosphate	14.5	14.5	14.5
Sodium metabisulfite	0.4	0.4	0.4
Polyvinylpyrrolidone	17.4	-	-
Cyclodextrin	-	17.4	-
Sorbitol	-	-	17.4
Microcrystalline cellulose	17.7	17.7	17.7
Sodium lauryl sulfate	0.7	0.7	0.7

II. Evaluation of the stability of the dyeing compositions

2.1. Protocol

5 After storage for one month at 45°C, each of the compositions (A) to (A2) was mixed with water.

The stability of each of the compositions (A) to (A2) was then evaluated by measuring the percentage of H₂O₂ loss by oxidation-reduction titration with potassium permanganate.

10

2.2. Results

The percentages of H₂O₂ loss obtained for each of the compositions, according to the invention (A) and comparative compositions (A1) and (A2), are indicated in the table below.

15

	A invention	A1 comparative	A2 comparative
% H ₂ O ₂ loss	4%	21%	100%

The results obtained above show that the dyeing composition (A), prepared according to the present invention, *i.e.* comprising a polymer comprising at least one heterocyclic vinyl monomer (polyvinylpyrrolidone), is more stable over time than the comparative compositions (A1) and (A2) comprising other excipients.

Indeed, after storage for one month at 45°C, an H₂O₂ loss of only 4% is measured in the composition according to the invention.

Conversely, the comparative compositions (A1) and (A2) comprising an excipient other than polyvinylpyrrolidone have respectively lost 21% and 100% of H₂O₂.

III. Dyeing evaluation of the dyeing compositions

3.1. Protocol

Each of the compositions (A) to (A2) obtained previously was mixed with water in order to obtain the respective ready-to-use compositions (A) to (A2), according to the following proportions:

- 27.2 g of composition, and
- water qs 100 g.

The ready-to-use compositions thus obtained were then applied to locks of hair containing 90% grey hairs, in a bath ratio equal to 5:1. After a leave-on time of 30 minutes at 27°C (thermostated plate), the locks of hair were rinsed, shampooed and then dried.

The same protocol was applied using dyeing compositions (A) to (A2) stored for 1 month at 45°C.

The colorimetric measurements of each of the ready-to-use compositions were evaluated in the CIE L*a*b* system by means of a Minolta CM-3600D spectrophotometer.

In this L*a*b* system, L* represents the intensity of the colour, a* indicates the green/red colour axis and b* the blue/yellow colour axis.

The ΔE^* value was calculated from the $L^*a^*b^*$ values according to the following equation:

$$\Delta E^* = \sqrt{(L^* - L_0^*)^2 + (a^* - a_0^*)^2 + (b^* - b_0^*)^2}$$

5

The colour build-up (ΔE^*) was calculated on locks of untreated hair (L_0^* , a_0^* and b_0^*) and on locks of dyed hair (L^* , a^* and b^*). The higher the ΔE^* value, the better the build-up of the colour.

10

Then, the stability of the dyeing performance qualities ($\text{diff}\Delta E$), that is to say the change in the dyeing performance qualities, of the compositions (A) to (A2) was calculated by comparing the build-up of the colouring obtained using fresh dyeing compositions, i.e. applied directly after they have been prepared, ($\Delta E(t_0)$), with the build-up of the colouring obtained using dyeing compositions stored for 1 month at 45°C ($\Delta E(t_{1\text{month}})$) according to the following equation:

15

$$\text{diff}\Delta E = (\Delta E(t_0)) - (\Delta E(t_{1\text{month}}))$$

20

The higher the $\text{diff}\Delta E$ value, the more the dyeing performance qualities of the dyeing composition have been degraded.

3.2. *Results*

25

The $\text{diff}\Delta E$ values obtained for each of the dyeing compositions, according to the invention (A) and comparative compositions (A1) and (A2), are indicated in the table below.

	A invention	A1 comparative	A2 comparative
diff ΔE	3.5	5.2	15.0

30

The results obtained above show that the dyeing properties of the dyeing composition (A), prepared according to the present

invention, *i.e.* comprising a polymer comprising at least one heterocyclic vinyl monomer (polyvinylpyrrolidone), remain more stable over time than the dyeing properties provided by the comparative compositions (A1) and (A2), each comprising an excipient other than polyvinylpyrrolidone.

Even after one month of storage at 45°C, the composition according to the invention retains its dyeing properties, contrary to the comparative compositions.

10 B. Example 2

I. Preparation of the compositions

The dyeing composition (B), according to the invention, and the comparative dyeing compositions (B1) to (B3) that follow, in anhydrous powder form, were prepared from the ingredients of which the contents are indicated in the tables below (% in g of active material).

	B invention	B1 comparative	B2 comparative	B3 comparative
2,5-Toluenediamine sulfate	3.53	3.53	3.53	3.53
2,4-Diaminophenoxyethanol, HCl	0.12	0.12	0.12	0.12
Resorcinol	1.69	1.69	1.69	1.69
m-Aminophenol	0.34	0.34	0.34	0.34
Sodium percarbonate	44.89	44.89	44.89	44.89
Ammonium sulfate	3.68	3.68	3.68	3.68
Hydroxypropyl starch phosphate	14.71	14.71	14.71	14.71
Sodium metabisulfite	1.47	1.47	1.47	1.47
Polyvinylpyrrolidone	29.58	-	-	-
Talc	-	29.58	-	-

Cyclodextrin	-	-	29.58	-
Sodium sulfate	-	-	-	29.58

II. Evaluation of the stability of the dyeing compositions

2.1. Protocol

5 After storage for one month at 45°C, each of the compositions (B) to (B3) was mixed with water.

The stability of each of the compositions (B) to (B3) was then evaluated by measuring the percentage of H₂O₂ loss by oxidation-reduction titration with potassium permanganate.

10

2.2. Results

The percentages of H₂O₂ loss obtained for each of the compositions, according to the invention (B) and comparative compositions (B1) to (B3), are indicated in the table below.

15

	B	B1	B2	B3
	invention	comparative	comparative	comparative
% H ₂ O ₂ loss	1.7%	39%	25%	38%

20

The results obtained above show that the dyeing composition (B), prepared according to the present invention, *i.e.* comprising a polymer comprising at least one heterocyclic vinyl monomer (polyvinylpyrrolidone), is more stable over time than the comparative compositions (B1) to (B3) comprising other excipients.

25

Indeed, after storage for one month at 45°C, an H₂O₂ loss of only 1.7% is measured in the composition according to the invention. Conversely, the comparative compositions (B1) to (B3) comprising an excipient other than polyvinylpyrrolidone have respectively lost 39%, 25% and 38% of H₂O₂.

III. Dyeing evaluation of the dyeing compositions

3.1. Protocol

Each of the compositions (B) to (B3) obtained previously was
5 mixed with water in order to obtain the respective ready-to-use
compositions (B)-(B3), according to the following proportions:

- 27.2 g of composition, and
- water qs 100 g.

The ready-to-use compositions thus obtained were then applied
10 to locks of hair containing 90% grey hairs, in a bath ratio equal to 5:1.
After a leave-on time of 30 minutes at 27°C (thermostated plate), the
locks of hair were rinsed and then dried.

The same protocol was applied using dyeing compositions (B)
to (B3) stored for 1 month at 45°C.

15

The colorimetric measurements of each of the ready-to-use
compositions were evaluated in the CIE L*a*b* system by means of a
Minolta CM-3600D spectrophotometer.

In this L*a*b* system, L* represents the intensity of the
20 colour, a* indicates the green/red colour axis and b* the blue/yellow
colour axis.

The ΔE^* value was calculated from the L*a*b* values
according to the following equation:

$$25 \quad \Delta E^* = \sqrt{(L^* - L_0^*)^2 + (a^* - a_0^*)^2 + (b^* - b_0^*)^2}$$

The colour build-up (ΔE^*) was calculated on locks of untreated
hair (L_0^* , a_0^* and b_0^*) and on locks of dyed hair (L^* , a^* and b^*). The
higher the ΔE^* value, the better the build-up of the colour.

30

Then, the stability of the dyeing performance qualities
(diff ΔE), that is to say the change in the dyeing performance qualities,
of the compositions (B) to (B3) was calculated by comparing the
build-up of the colouring obtained using fresh dyeing compositions,

i.e. applied directly after they have been prepared, ($\Delta E(t_0)$), with the build-up of the colouring obtained using dyeing compositions stored for 1 month at 45°C ($\Delta E(t_{1\text{month}})$) according to the following equation:

$$\text{diff } \Delta E = (\Delta E^*(t_0)) - (\Delta E^*(t_{1\text{month}}))$$

The higher the $\text{diff } \Delta E$ value, the more the dyeing performance qualities of the dyeing composition have been degraded.

10 3.2. *Results*

The $\text{diff } \Delta E$ values obtained for each of the dyeing compositions, according to the invention (B) and comparative compositions (B1) to (B3), are indicated in the table below.

	B invention	B1 comparative	B2 comparative	B3 comparative
$\text{diff } \Delta E$	1.80	17.07	14.75	17.91

15

The results obtained above show that the dyeing properties of the dyeing composition (B), prepared according to the present invention, *i.e.* comprising a polymer comprising at least one heterocyclic vinyl monomer (polyvinylpyrrolidone), remain more stable over time than the dyeing properties provided by the comparative compositions (B1) to (B3), each comprising an excipient other than polyvinylpyrrolidone.

20

Even after one month of storage at 45°C, the composition according to the invention retains its dyeing properties, contrary to the comparative compositions.

25

CLAIMS

1. Anhydrous solid composition for dyeing keratin fibres, in particular human keratin fibres such as the hair, comprising:
- (a) one or more oxidation bases,
 - 5 (b) one or more chemical oxidizing agents chosen from alkali metal percarbonates, alkaline-earth metal percarbonates and mixtures thereof,
 - (c) one or more polymers comprising at least one heterocyclic vinyl monomer, and
 - 10 (d) optionally one or more oxidation couplers.
2. Composition according to Claim 1, characterized in that the oxidation base(s) are chosen from para-phenylenediamines, bis(phenyl)alkylenediamines, para-aminophenols, bis-para-aminophenols, ortho-aminophenols and heterocyclic bases, the addition salts thereof, the solvates thereof, and mixtures thereof, and preferably from para-phenylenediamines, the addition salts thereof, the solvates thereof, and mixtures thereof.
- 15
3. Composition according to Claim 1 or 2, characterized in that the total amount of oxidation base(s) ranges from 0.1% to 30% by weight, preferably from 0.5% to 15% by weight and more preferentially from 1% to 10% by weight relative to the total weight of the anhydrous solid dyeing composition.
- 20
4. Composition according to any one of the preceding claims, characterized in that the total amount of chemical oxidizing agent(s), chosen from alkali metal percarbonates, alkaline-earth metal percarbonates and mixtures thereof, ranges from 30% to 55% by weight, and preferably from 35% to 50% by weight, relative to the total weight of the anhydrous solid dyeing composition.
- 25
- 30

5. Composition according to any one of the preceding claims, characterized in that the heterocyclic vinyl monomer is chosen from monomers comprising a 4- to 7-membered heterocycle, and comprising from 1 to 4 identical or different intracyclic heteroatoms, which is optionally fused to a benzene ring and/or optionally substituted; the number of intracyclic heteroatoms being less than the number of ring members of the heterocycle.

6. Composition according to Claim 5, characterized in that the heterocyclic vinyl monomer is chosen from optionally substituted N-vinyl monomers, preferably from N-vinylpyrrolidone, vinylcaprolactam, N-vinylpiperidone, N-vinyl 3-morpholine, N-vinyl-4-oxazolinone, 2-vinylpyridine, 4-vinylpyridine, 2-vinylquinoline, 1-vinylimidazole and 1-vinylcarbazole, which are optionally substituted, and more preferentially the heterocyclic monomer is optionally substituted N-vinylpyrrolidone.

7. Composition according to any one of the preceding claims, characterized in that the polymer comprising at least one heterocyclic vinyl monomer is the crosslinked or non-crosslinked polyvinylpyrrolidone homopolymer.

8. Composition according to any one of the preceding claims, characterized in that the total amount of polymer(s) comprising at least one heterocyclic vinyl monomer ranges from 5% to 70% by weight, preferably from 10% to 60% by weight and more preferentially from 10% to 35% by weight relative to the total weight of the anhydrous solid dyeing composition.

9. Composition according to any one of the preceding claims, characterized in that the oxidation coupler(s) are chosen from meta-phenylenediamines, meta-aminophenols, meta-diphenols, naphthalene-based couplers and heterocyclic couplers, the addition salts thereof, the solvates thereof, and mixtures thereof.

10. Composition according to any one of the preceding claims, characterized in that it also comprises one or more surfactants, preferably chosen from anionic surfactants, amphoteric or zwitterionic surfactants, non-ionic surfactants, cationic surfactants and mixtures thereof, and more preferentially from anionic surfactants and mixtures thereof.

11. Composition according to any one of the preceding claims, characterized in that it also comprises one or more alkaline agents, preferably chosen from silicates and metasilicates, such as alkali metal metasilicates; alkali metal or alkaline-earth metal carbonates or hydrogen carbonates, ammonium salts, and mixtures thereof.

12. Ready-to-use composition resulting from the mixing of an anhydrous solid dyeing composition, as defined in any one of the preceding claims, and of a cosmetically acceptable medium.

13. Packaging article comprising:

i) an envelope defining at least one cavity, the envelope comprising water-soluble and/or liposoluble fibres, preferably water-soluble fibres; and

ii) an anhydrous solid dyeing composition as defined in any one of Claims 1 to 11;

it being understood that the anhydrous solid dyeing composition is in one of the cavities defined by the envelope i).

14. Packaging article according to Claim 13, characterized in that the envelope i) is constituted of two water-soluble or liposoluble sheets (11, 12), which are preferably water-soluble, joined together at a peripheral region (14), the two sheets preferably being joined by any suitable fixing means, preferably gluing, welding, especially heat-welding, in particular by entanglement; the first sheet (11) also has a free central region (D) arranged facing a free central region (D) of the second sheet (12); these two central regions defining a central cavity, said central cavity containing the anhydrous solid dyeing composition

(13); the sheets (11, 12) having a closed outer periphery (15) of which the shape is rounded, preferably circular or elliptical, or polygonal, preferably square, rectangular or triangular, and more preferentially circular.

5

15. Packaging article according to Claim 14, characterized in that it also comprises a sheet (16), which is preferably water-soluble, and optionally other additional water-soluble or liposoluble sheet(s) (17), which are preferably water-soluble, which define one or more
10 cavities, separating the anhydrous solid dyeing composition (13), one or more additional chemical oxidizing agents which are different from the chemical oxidizing agents (b) and/or one or more additives (19), and/or one or more additives which are different from those introduced into the other cavities (20).

15

16. Packaging article according to either one of Claims 14 and 15, characterized in that the first sheet (11), the second sheet (12) and optionally the additional sheets (16) and (17) have a thickness smaller than their other dimensions, especially less than 10% of their
20 maximum transverse dimensions $D+2d$; preferentially, the thickness of the first sheet (11) and of the second sheet (12) being in particular less than 10 mm and especially between 0.1 mm and 3 mm, and their maximum transverse dimensions $D+2d$ being less than 100 mm, and especially being inclusively between 10 mm and 60 mm, d defining a
25 peripheral region which joins together the two sheets (11) and (12) hermetically.

25

17. Packaging article according to any one of Claims 14 to 16, characterized in that the first sheet (11) is a nonwoven and the second
30 sheet (12) is a nonwoven; said article also has a closed outer periphery (15); the outer periphery (15) of the first layer (11) is identical in shape to the outer periphery (15) of the second layer (12).

30

18. Process for dyeing keratin fibres, in particular human keratin fibres such as the hair, comprising the following successive steps:

- 5 - applying to said keratin fibres a ready-to-use composition as defined in Claim 12,
- leaving the ready-to-use composition on said keratin fibres,
- rinsing said keratin fibres, and
- optionally shampooing said keratin fibres, rinsing them and drying them.

10

19. Process for dyeing keratin fibres, in particular human keratin fibres such as the hair, comprising the following successive steps:

- 15 - mixing a packaging article, as defined in any one of Claims 13 to 17, with a composition capable of dissolving the envelope of said packaging article,
- applying the resulting composition to said keratin fibres,
- leaving said resulting composition on said keratin fibres,
- rinsing said keratin fibres, and
- 20 - optionally shampooing said keratin fibres, rinsing them and drying them.

20. Use of an anhydrous solid dyeing composition, as defined in any one of Claims 1 to 11, for dyeing keratin fibres, and in particular human keratin fibres such as the hair.

25

21. Use of a packaging article, as defined in any one of Claims 13 to 17, for dyeing keratin fibres, and in particular human keratin fibres such as the hair.

30

FIG. 1a

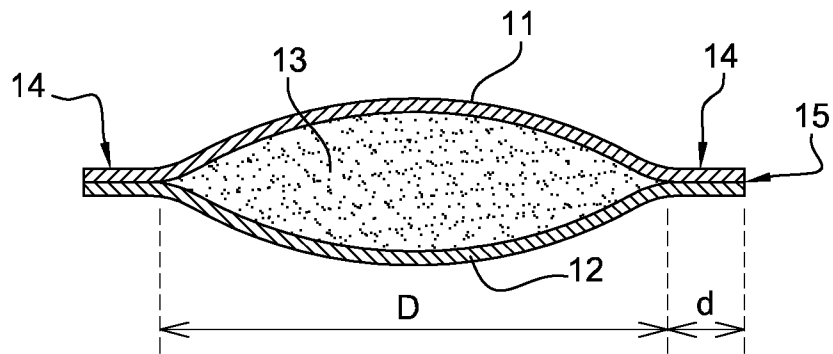

FIG. 1b

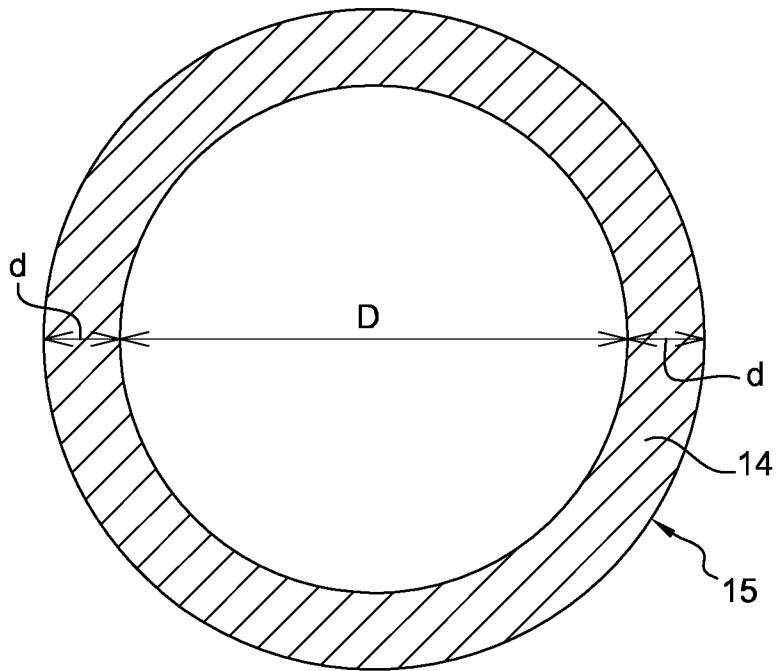
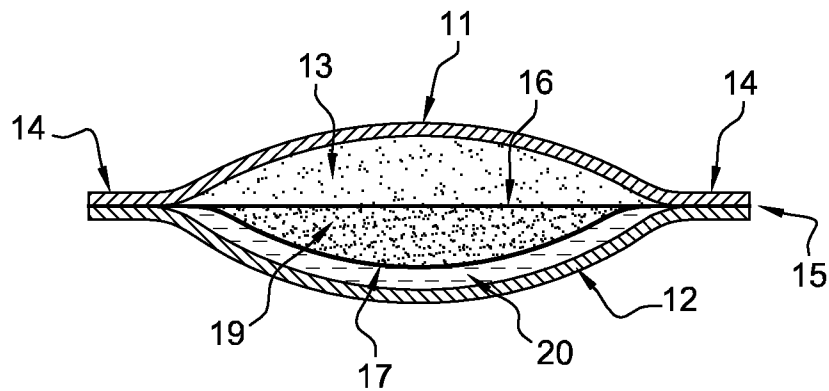

FIG. 1c



2/2
FIG.1d

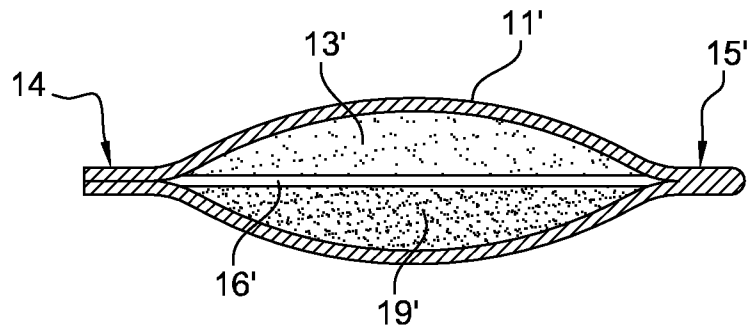
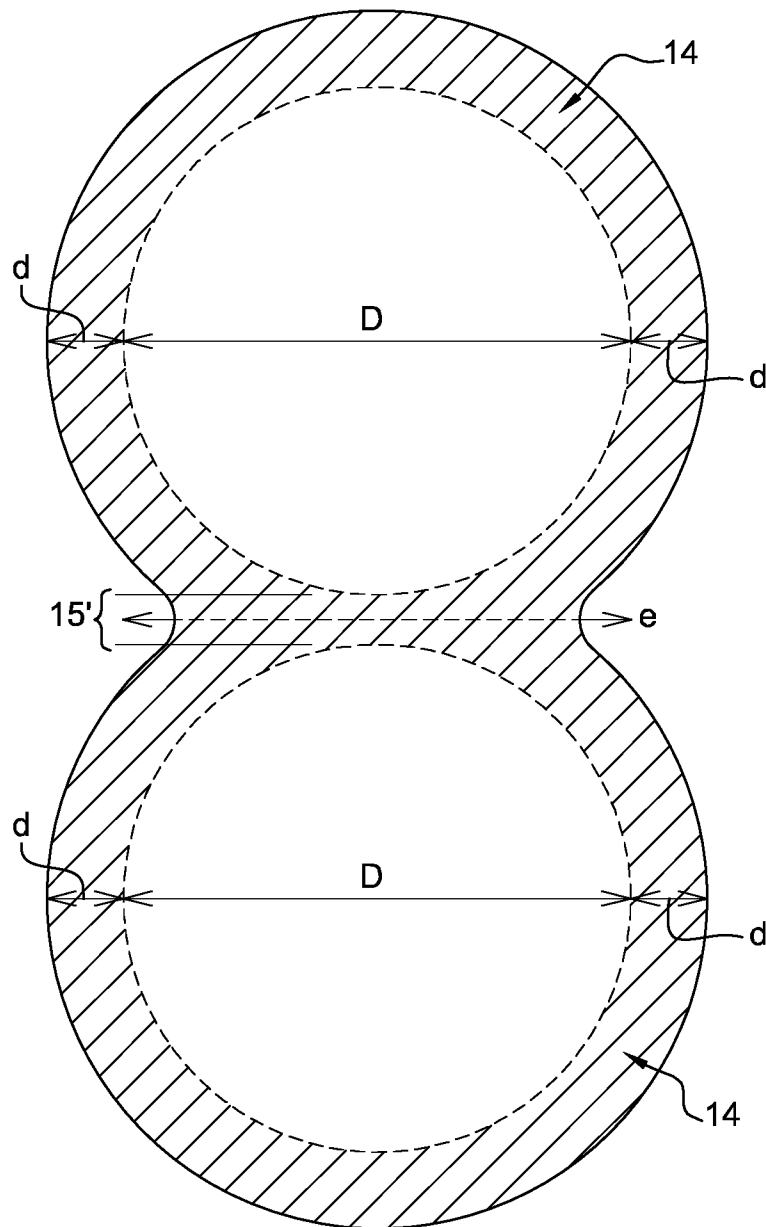

FIG.1e



INTERNATIONAL SEARCH REPORT

International application No
PCT/EP2017/083442

A. CLASSIFICATION OF SUBJECT MATTER
 INV. A61Q5/10 A61K8/02 A61K8/22 A61K8/81 A61K8/11
 A45D33/00
 ADD.
 According to International Patent Classification (IPC) or to both national classification and IPC

B. FIELDS SEARCHED
 Minimum documentation searched (classification system followed by classification symbols)
 A61K A61Q C11D

Documentation searched other than minimum documentation to the extent that such documents are included in the fields searched

Electronic data base consulted during the international search (name of data base and, where practicable, search terms used)
 EPO-Internal, WPI Data

C. DOCUMENTS CONSIDERED TO BE RELEVANT

Category*	Citation of document, with indication, where appropriate, of the relevant passages	Relevant to claim No.
A	FR 3 015 232 A1 (OREAL [FR]) 26 June 2015 (2015-06-26) page 2, line 34 - page 3, line 5 page 21, line 33 - line 36 page 26, line 5 - line 19 Composition C; page 41	1-21
X	FR 2 917 973 A1 (OREAL [FR]) 2 January 2009 (2009-01-02) page 2, line 22 - line 30 page 3, line 10 - line 13 page 10, line 34 - line 37	1,11,12, 18,20
	----- -/--	

Further documents are listed in the continuation of Box C.

See patent family annex.

* Special categories of cited documents :

- "A" document defining the general state of the art which is not considered to be of particular relevance
- "E" earlier application or patent but published on or after the international filing date
- "L" document which may throw doubts on priority claim(s) or which is cited to establish the publication date of another citation or other special reason (as specified)
- "O" document referring to an oral disclosure, use, exhibition or other means
- "P" document published prior to the international filing date but later than the priority date claimed

- "T" later document published after the international filing date or priority date and not in conflict with the application but cited to understand the principle or theory underlying the invention
- "X" document of particular relevance; the claimed invention cannot be considered novel or cannot be considered to involve an inventive step when the document is taken alone
- "Y" document of particular relevance; the claimed invention cannot be considered to involve an inventive step when the document is combined with one or more other such documents, such combination being obvious to a person skilled in the art
- "&" document member of the same patent family

Date of the actual completion of the international search 9 March 2018	Date of mailing of the international search report 19/03/2018
---	--

Name and mailing address of the ISA/ European Patent Office, P.B. 5818 Patentlaan 2 NL - 2280 HV Rijswijk Tel. (+31-70) 340-2040, Fax: (+31-70) 340-3016	Authorized officer Simon, Frédéric
--	---

INTERNATIONAL SEARCH REPORT

International application No
PCT/EP2017/083442

C(Continuation). DOCUMENTS CONSIDERED TO BE RELEVANT		
Category*	Citation of document, with indication, where appropriate, of the relevant passages	Relevant to claim No.
X	FR 2 917 967 A1 (OREAL [FR]) 2 January 2009 (2009-01-02) page 2, line 22 - line 30 page 3, line 10 - line 15 page 8, line 32 - line 34 -----	1,11,12, 18,20
X A	US 2012/317734 A1 (MARTINEZ-SANTIAGO JOSE [US] ET AL) 20 December 2012 (2012-12-20) examples 4-11 paragraphs [0019], [0045], [0062], [0063], [0118] -----	12,18,20 1-11, 13-17, 19,21
X	FR 2 197 950 A2 (OREAL [FR]) 29 March 1974 (1974-03-29) examples 1-7 -----	12,20

INTERNATIONAL SEARCH REPORT

Information on patent family members

International application No

PCT/EP2017/083442

Patent document cited in search report	Publication date	Patent family member(s)	Publication date
FR 3015232	A1	26-06-2015	CN 105828884 A 03-08-2016
			EP 3086859 A1 02-11-2016
			FR 3015232 A1 26-06-2015
			US 2016367447 A1 22-12-2016
			WO 2015097099 A1 02-07-2015

FR 2917973	A1	02-01-2009	NONE

FR 2917967	A1	02-01-2009	NONE

US 2012317734	A1	20-12-2012	NONE

FR 2197950	A2	29-03-1974	BE 801366 R 26-12-1973
			CA 998208 A 12-10-1976
			CH 572964 A5 27-02-1976
			DE 2332157 A1 17-01-1974
			FR 2197950 A2 29-03-1974
			GB 1388240 A 26-03-1975
			IT 1046528 B 31-07-1980
			JP S4952825 A 22-05-1974
			LU 65590 A1 04-01-1974
NL 7308790 A 28-12-1973			
