

C. F. PEASE.
 BLUE PRINT MACHINE.
 APPLICATION FILED JULY 26, 1910.

998,259.

Patented July 18, 1911.

3 SHEETS-SHEET 1.

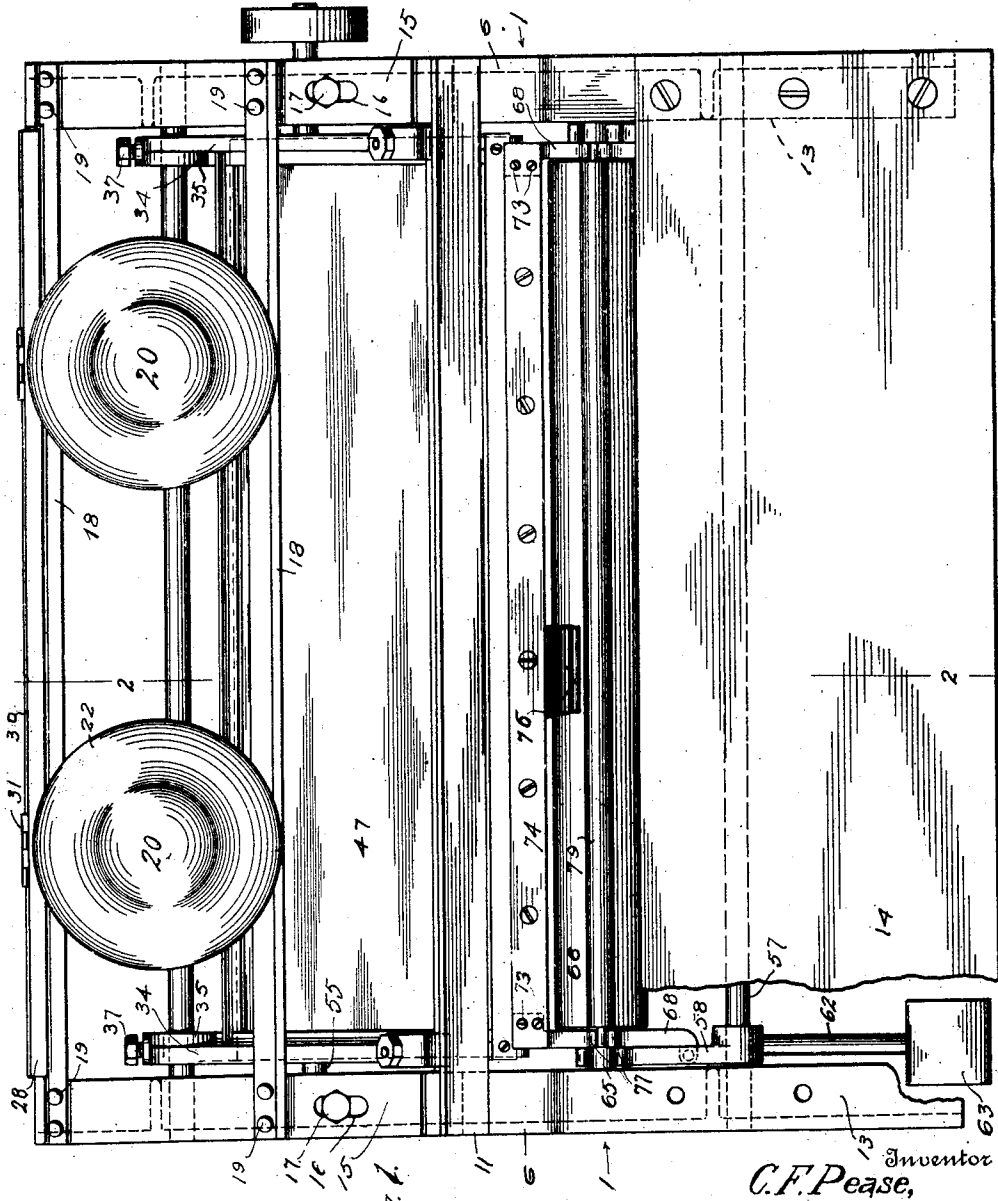

Witnesses
J. S. Freeman.
W. H. Ashburne

Fig. 1.

384 *C. L. Parker,* Attorney

C. F. PEASE.
 BLUE PRINT MACHINE.
 APPLICATION FILED JULY 26, 1910.

998,259.

Patented July 18, 1911.

3 SHEETS—SHEET 2.

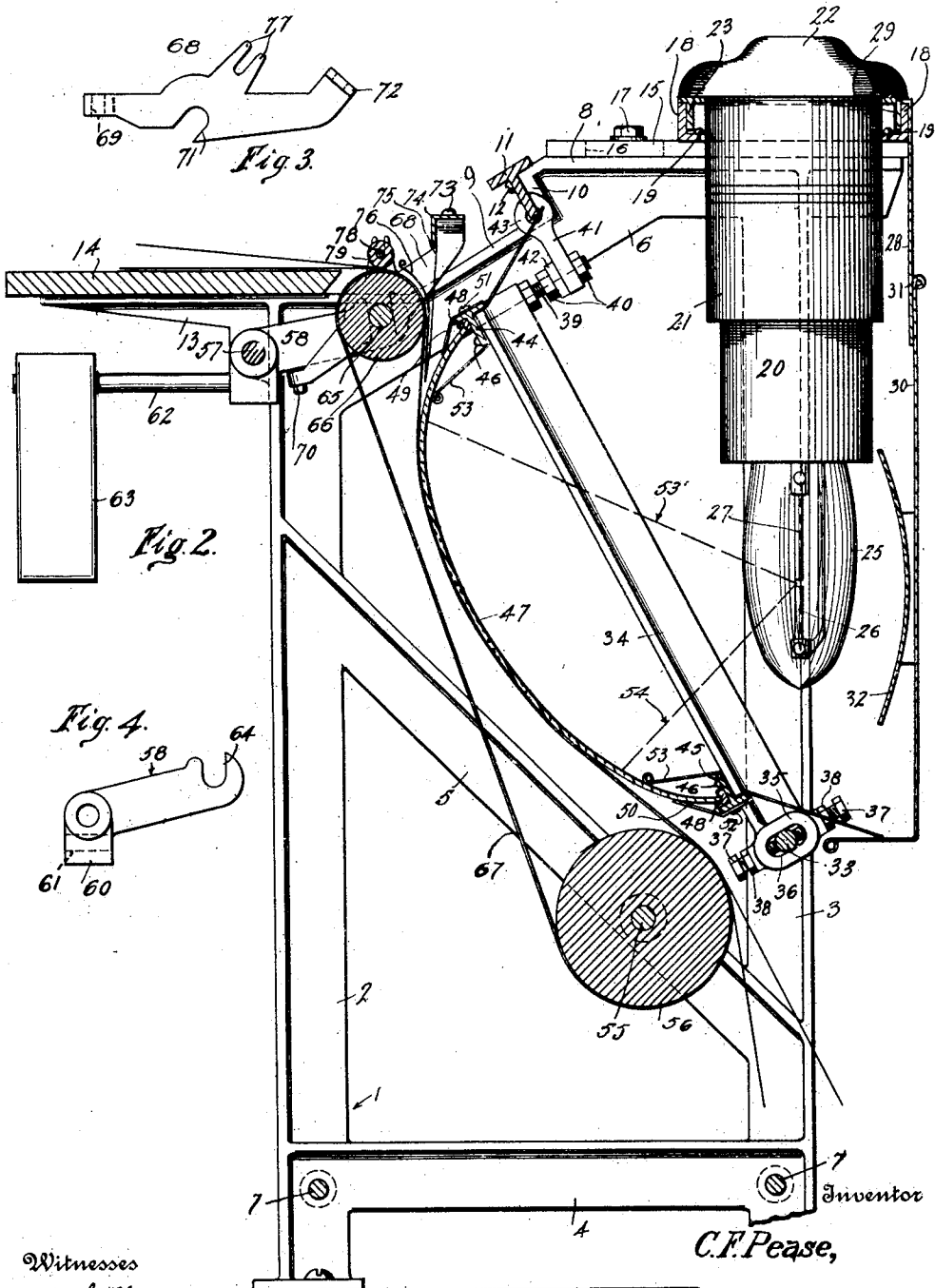

Witnesses
J. S. Freeman.
B. M. Ashburne

By *C. L. Parker,* Attorney

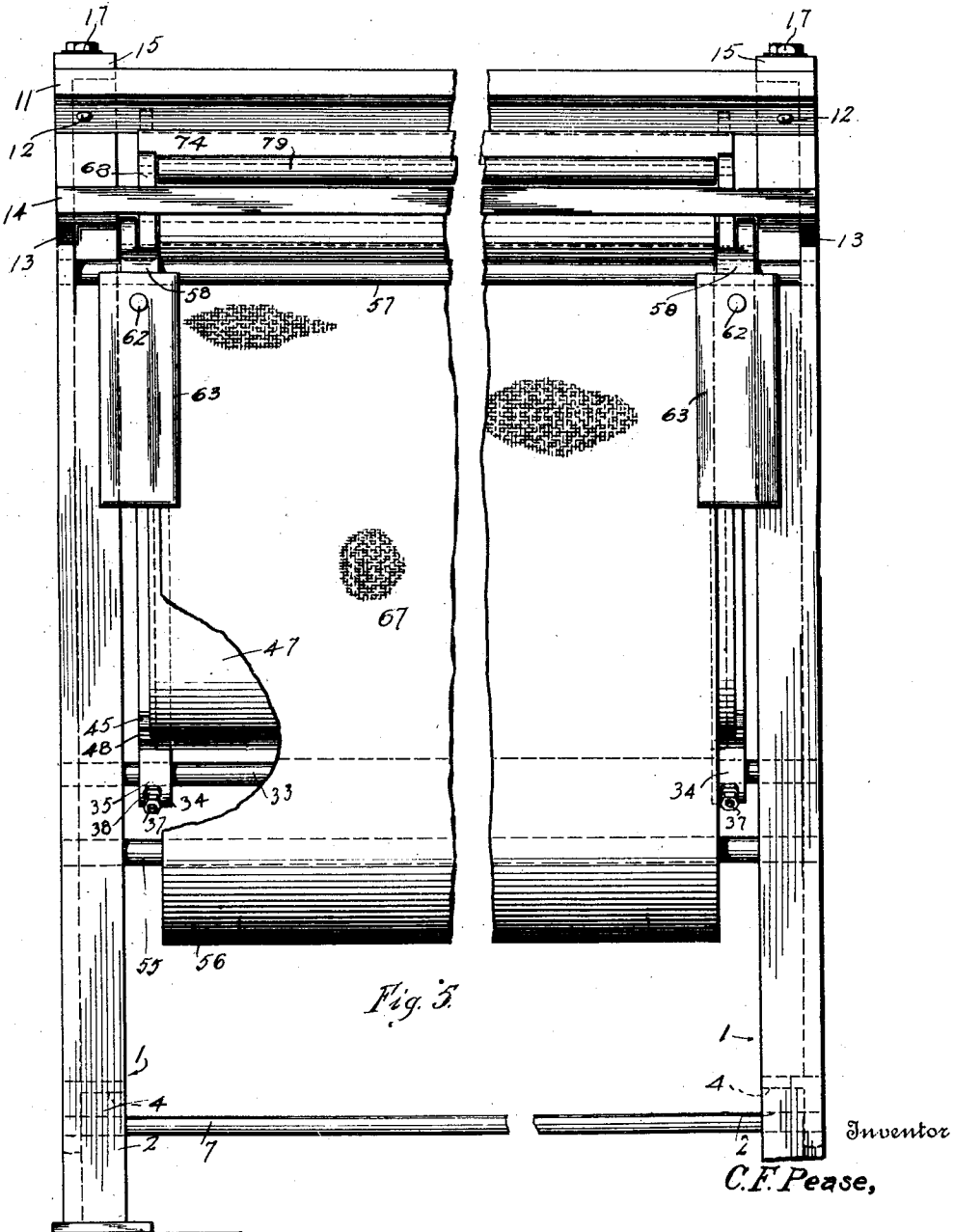

Witnesses,
J. S. Freeman.
B. M. Schuman

By
C. L. Parken.

Attorney

Inventor
C. F. Pease,

UNITED STATES PATENT OFFICE.

CHARLES F. PEASE, OF CHICAGO, ILLINOIS, ASSIGNOR TO THE C. F. PEASE COMPANY,
OF CHICAGO, ILLINOIS, A CORPORATION OF ILLINOIS.

BLUE-PRINT MACHINE.

998,259.

Specification of Letters Patent.

Patented July 18, 1911.

Application filed July 26, 1910. Serial No. 573,959.

To all whom it may concern:

Be it known that I, CHARLES F. PEASE, a citizen of the United States, residing at Chicago, in the county of Cook and State of Illinois, have invented certain new and useful Improvements in Blue-Print Machines, of which the following is a specification.

My invention relates to a machine for making photographic copies of drawings, or the like.

An important object of this invention is to provide a machine of the above character, so constructed that a maximum amount of light may be thrown upon the print and drawing without danger of cracking the transparent printing plate across which such print and drawing are fed.

A further object of this invention is to provide a machine of the above character, including a transparent printing plate across which the print and tracing are fed, said plate being so positioned as to avoid uneven heating from the heat rays of the arc.

A further object of my invention is to provide a machine of the above character including a transparent printing plate across which the print and tracing are fed, such plate being so shaped and positioned that said print and tracing may be easily fed across said plate from the feed table.

A further object of this invention is to provide means for supporting the transparent printing plate, which will permit the plate to be swung toward the lamps, so that said plate may be cleaned without moving the lamps.

A further object of this invention is to provide means whereby the transparent printing plate may be so adjusted that the creeping of the endless belt toward either end of its rollers may be prevented.

Other objects and advantages of this invention will appear in the course of the following description.

In the accompanying drawings forming a part of this specification, and in which like numerals are employed to designate like parts throughout the same, Figure 1 is a top plan view of the machine. Fig. 2 is a central vertical section through the same, taken on line 2—2 of Fig. 1. Fig. 3 is a detail elevation of one of the brackets used upon the machine. Fig. 4 is a similar view of one of

the bell crank levers, and Fig. 5 is a front elevation of the machine.

In the drawings, wherein is illustrated a preferred embodiment of my invention, the numeral 1 designates pairs of castings, which form the supporting means for the other parts of the machine, to be described. Each of the castings 1 comprises uprights 2 and 3, which are connected near their lower ends by a transverse section 4. Each casting further comprises a diagonal section 5 and a section 6, connecting the upper ends of the uprights 2 and 3, as shown. The castings 1 are connected by means of transverse rods 7, which are fixedly secured to the lower ends of the uprights 2 and 3. The section 6 of each of the castings 1 is provided with a horizontal portion 8 and an inclined portion 9, which forms a shoulder 10 with said horizontal portion. A T-iron 11 is connected with the shoulder 10 of each of the sections 6, as shown at 12, for preventing the upper ends of the castings 1 from being moved away from each other. Each of the uprights 2 is extended forwardly at its upper end to form a bracket 13 for supporting a plank 14, constituting a feed table.

Slidably mounted upon the horizontal portions 8 of the sections 6, are pairs of strips 15, having elongated slots 16 formed therethrough, as clearly shown in Fig. 1, for receiving clamping bolts 17. These bolts suitably engage the sections 6, for clamping the strips 15 to the same. These strips 15 are thus adjustable transversely of the castings 1 and may be locked in desired positions. The strips 15 are connected by rails 18, which are L-shaped in cross-section and rigidly secured to said strips, as shown at 19. The strips 15, together with the rails 18, constitute a carriage for supporting arc-lamps 20. These arc-lamps may be of any well known or preferred form, and, as shown, each comprises a cylindrical body casing 21, within which are disposed the ordinary parts of the lamp. The upper end of the casing 21 is provided with a circular cover 22, extending laterally beyond the casing 21 and having an annular T-rail 23 fixedly secured to its lower surface, as shown. This annular T-rail is adapted to fit between the rails 18 and thereby support the arc-lamps. Each of the arc-lamps 20 further comprises a globe 25 formed of suitable

transparent material, within which are disposed the carbons 26 and 27, the same being supported in the usual manner. As is customary, the upper carbon 27 is the positive element and the lower carbon 26 the negative. As no claim will be made to these arc-lamps *per se*, no further description of them will be given. In the drawings, two arc-lamps are shown, but it is to be understood that any number of these lamps may be employed, when necessary. The arc-lamps may be adjusted longitudinally of their carriage, while said carriage may be moved transversely of the machine, as above stated. The rear rail 18 has a section of sheet metal 28 secured thereto, as shown at 29. This section of sheet metal has a lid 30 hinged thereto, as shown at 31, which is provided with reflectors 32. There are a corresponding number of reflectors and lamps. Each reflector may preferably be formed of a concave mirror.

The rear uprights 3 are connected near their centers by a cylindrical rod 33, upon which are pivotally mounted spaced levers 34. Each of the levers 34 has its lower end provided with an enlarged head 35, through which is formed an elongated transverse slot 36 for receiving the shaft 33. The head 35 is provided through its opposite ends, with screw threaded openings for the reception of bolts 37. The lever 34 is capable of oscillating upon the shaft 33 and to be adjusted laterally with relation to said shaft by the proper manipulation of the bolts 37. Each of the bolts 37 is preferably provided with a locking nut 38, which may be rotated to clamp the head 35 and thus prevent the accidental movement of the bolt 37. The upper end of each of the levers 34 has a bolt 39 rigidly connected therewith in any suitable manner, which is provided with nuts 40, between which are disposed a gripping member 41 and a washer 42. The gripping member 41 is provided with spaced jaws 43 for detachable engagement with the T-iron 11. This gripping member may be oscillated to disengage said T-iron, whereby the lever 34 may be oscillated rearwardly toward the arc-lamp. The gripping member 41 may be adjusted longitudinally of the bolt 39, by the proper manipulation of the bolts 40, so that the locked inclined position of the lever 34 may be varied. The levers 34 are connected by T-irons 44 and 45, rigidly secured to the same near their upper and lower ends respectively, as shown at 46. The levers 34, together with the T-irons 44 and 45, constitute an adjustable support for a preferably transparent printing plate 47, which may be formed of glass. This printing plate may be translucent instead of transparent, and will be referred to in the claims as a printing plate. The plate 47 is approximately semi-elliptical in vertical

cross-section and is arranged so that the major axis of the ellipse is disposed at an inclined position with relation to the carbons 26 and 27. The printing plate 47 is supported by the T-irons 44 and 45, and engage suitable shock-absorbing members 48, disposed upon said T-irons. The printing plate 47 is retained in its proper position upon said T-irons by means of brackets 49 and 50, which are rigidly connected with the T-irons 44 and 45, respectively, as shown at 51 and 52. Brackets 53 are also provided which engage the plate 47 upon its concave side and cooperate with brackets 49 and 50 for retaining said plate in its proper position. The printing plate 47 may be removed by taking off the brackets 49 and 50. As clearly illustrated in Fig. 2, the lower end of the printing plate 47 is disposed much nearer the carbons 26 and 27 than the upper end of said plate, and this arrangement affords a decided advantage, to be next described. As heated air rises the upper portion of the printing plate 47 would be subjected to a greater degree of heat than the lower portion if the printing plate were flat and disposed in the same position with relation to the arc. By my arrangement of the transparent printing plate all parts of the same are subjected to substantially the same degree of heat, thus provided for, the printing plate 47 will not be liable to crack, and the arc-lamps may be positioned nearer the same than would otherwise be possible.

The diagonal sections 5 of the castings 1, have a horizontally disposed shaft 55 journaled therethrough, upon which is rigidly mounted a roller 56. Means (not shown) are to be provided to effect the rotation of the shaft 55. A rock shaft 57 is journaled through depending portions of the extensions 13, and extends horizontally for the entire length of the machine. This rock shaft is provided near its ends with levers 58, which are rigidly secured to the same in any desired manner. The levers 58 are bell-crank levers, and each is provided with a vertical arm 60, having a transverse opening 61 formed therethrough, for receiving a shaft 62, upon which is adjustably mounted a weight 63. Each of the levers 58 has its free end provided with an opening 64 for rotatably holding a horizontal shaft 65, upon which is mounted a second roller 66. This roller 66 is disposed in a vertical plane forwardly of the roller 56. Trained about the rollers 66 and 56, is an endless belt 67 formed of canvas, or the like, and which is adapted to engage the plate 47 and conform to the curvature of the same, as clearly illustrated in Fig. 2. Adjacent and inwardly of each of the levers 58, is disposed a bracket 68, which has the shape shown in Fig. 3. This bracket has its lower

end off-set and provided with a transverse opening 69, to receive a bolt 70 for connecting said bracket with the lever 58. The lower edge of the bracket 68 is provided with a cut-out portion 71 to loosely receive the shaft 65. The upper end of each of the brackets 68 is bent at right angles to form a portion 72, which is apertured to receive screws 73, or the like, for securing a rail 74 to said bracket. The rail 74 has a sheet metal guide member 75 suitably secured thereto, which is bent upon itself to form a portion 76, curved in vertical cross-section and disposed near the roller 66, as shown. Each of the brackets 68 is provided upon its upper edge and centrally thereof, with spaced ears 77, to rotatably support a shaft 78, carrying a feed roller 79, which is disposed above and in engagement with the endless belt 67.

In the operation of the machine, the endless belt 67 is set in motion and the print and drawing fed between the roller 79 and the endless belt. The print and drawing are then conducted by the guide member 76, between said endless belt and printing plate 47. The print and drawing travel downwardly and are discharged from the roller 56, as shown. When in operation, should the endless belt 67 move laterally toward one end of either of the rollers 66 and 56, such lateral movement may be controlled or prevented by properly adjusting the lower end of either of the levers 34 with relation to the rod 33, it being understood that the lever toward which the endless belt moves laterally, is adjusted toward said endless belt. The adjustment of the lower ends of the levers 34, is effected by the proper operation of the bolts 37.

I wish it understood that the form of my invention herewith shown and described, is to be taken as a preferred example of the same, and that certain changes in the shape, size and arrangement of parts may be resorted to without departing from the spirit of my invention or the scope of the subjoined claims.

Having thus fully described my invention what I claim as new and desire to secure by Letters Patent, is:—

1. In a machine of the character described, a supporting structure, a source of light, a printing plate disposed near said source of light and so arranged that the distance between the same and said source of light increases toward the upper end thereof, a flexible endless belt to operate in engagement with said printing plate, and means to hold the upper end of said plate in adjustment at different distances from said source of light.

2. In a machine of the character described, a supporting structure, a source of light connected therewith, supporting means having

one end thereof pivotally connected with said supporting structure, means to hold the opposite end of said supporting means in adjustment at different distances from said source of light, a printing plate connected with said supporting means, and an endless belt to operate in engagement with said printing plate.

3. In a machine of the character described, a supporting structure, a source of light, supporting means pivotally connected with said supporting structure, means to change the position of the pivotal axis of said supporting means, a printing plate connected with said supporting means, and an endless belt to operate in engagement with said printing plate and prevented from moving laterally by virtue of the position of said pivotal axis.

4. In a machine of the character described, a supporting structure, a source of light connected therewith, a printing plate, supporting means for said plate having pivotal connection with said supporting structure, paper feeding means to operate in engagement with said printing plate, means to change the position of the pivotal axis of said supporting means, whereby said paper feeding means is prevented from moving laterally, and means to hold said supporting means in adjustment at different distances from said source of light.

5. In a machine of the character described, a supporting structure, a source of light connected therewith, a printing plate disposed near said source of light, an endless belt to operate in engagement with said printing plate, and means to support and hold said printing plate in adjustment at different angles with relation to the portion of said endless belt which is out of engagement with said printing plate, for preventing said endless belt from moving laterally.

6. In a machine of the character described, a supporting structure, a source of light connected therewith, a printing plate disposed near said source of light, paper feeding means to operate in engagement with said printing plate, and means to support and fixedly hold said printing plate in adjustment at different angles with relation to the portion of said feeding means, which is out of engagement with said printing plate.

7. In a machine of the character described, a supporting structure, a source of light connected therewith, a printing plate disposed near said source of light, a plurality of rollers disposed in operative relation to said source of light, an endless belt trained about said rollers, and means to support and hold said printing plate in adjustment at different angles with relation to the portion of said endless belt which is out of engagement with said printing plate, for preventing said endless belt from moving laterally.

8. In a machine of the character described, a support, a source of light, a printing plate arranged near said source of light, supporting means for said printing plate including pivoted levers, an endless belt to operate in engagement with said printing plate, and means to change the pivot point of each of the levers to prevent the lateral movement of said endless belt in that direction.

9. In a machine of the character described, a support, a source of light, a printing plate arranged near said source of light, supporting means for said printing plate including a plurality of levers, an endless belt to operate in engagement with said printing plate, and means to move one end of either lever toward said endless belt to prevent the lateral movement of said endless belt in that direction.

10. In a machine of the character described, a supporting structure, a carriage mounted upon the upper portion of the same in such a manner as to be moved transversely thereof, a source of light connected with said carriage, a printing plate disposed near said source of light, paper feeding means to operate in engagement with said printing plate, and means for pivotally connecting said printing plate with said supporting structure, whereby said printing plate may be oscillated out of engagement with said paper feeding means, when it is desired to clean said printing plate.

11. In a machine of the character described, a supporting structure, a carriage mounted upon the upper portion of the same in such a manner that the same may be moved transversely of said supporting structure, a source of light connected with said carriage, a printing plate disposed near said source of light, paper feeding means to operate in engagement with said printing plate, means pivotally connecting said printing plate with said supporting structure whereby the former may be moved out of engagement with said paper feeding means, and means to hold the upper portion of said printing plate in adjustment at different distances from said source of light.

12. In a machine of the character described, a supporting structure, a carriage mounted upon said supporting structure and normally capable of being moved transversely of the same, a source of light mounted upon said carriage, means to rigidly lock said carriage with said supporting structure, a printing plate disposed near said source of light, paper feeding means to operate in engagement with said printing plate, and means pivotally connecting said printing plate and supporting structure whereby the former may be moved out of engagement with said paper feeding means.

13. In a machine of the character described, a supporting structure, a source of light mounted upon said supporting structure in such a manner that the same may be moved transversely and longitudinally of said supporting structure, a printing plate connected with said supporting structure and disposed near said source of light, and paper feeding means to operate in engagement with said printing plate.

14. In a machine of the character described, a supporting structure, a carriage transversely movably mounted thereon, a source of light longitudinally movably mounted upon said carriage, a printing plate curved in cross-section disposed near said source of light, and paper feeding means operating in engagement with said printing plate.

15. In a machine of the character described, a supporting structure, a carriage mounted upon the upper portion of said supporting structure and movable transversely thereof, said carriage including transverse strips provided with elongated slots formed therethrough, clamping means connected with said supporting structure, and disposed within said slots, a source of light connected with said carriage, a printing plate disposed near said source of light, means pivotally connecting said printing plate and supporting structure, and an endless belt to operate in engagement with said printing plate.

16. In a machine of the character described, a supporting structure, a rotatable shaft, a roller mounted upon the same, swinging brackets for supporting said rotatable shaft, brackets connected with the first named brackets and having openings formed in the lower portions thereof for receiving said rotatable shaft, a feed roller rotatably supported by the second named brackets, a guide member connected with said second named brackets, a roller disposed below the first named roller, an endless belt trained about the first and third named rollers, a printing plate to cooperate with said endless belt, and a source of light arranged near said printing plate.

17. In a machine of the character described, a supporting structure, a source of light connected therewith, a printing plate disposed near said source of light, paper feeding means to cooperate with said printing plate, including upper and lower rollers and an endless belt trained thereabout, swinging means for supporting the upper roller, a feed roller disposed near the upper roller, supporting means for said feed roller, connected with said swinging means, whereby the feed roller and upper roller are moved together by said swinging means, and a weight connected with said swinging means.

18. In a machine of the character described, a supporting structure, a source of light connected therewith, a printing plate disposed near said source of light, paper feeding means to coöperate with said printing plate, including upper and lower rollers and an endless belt trained thereabout, swinging means for supporting the upper roller, a feed roller disposed near the upper roller, and supporting means for said feed roller, connected with said swinging means, whereby said feed roller and upper roller are moved together by said swinging means.

19. In a machine of the character described, a supporting structure, a source of light, a printing plate arranged to coöperate therewith, paper feeding means to coöperate with said printing plate, including upper and lower rollers and an endless belt trained thereabout, a feed roller disposed near the upper roller, and common swinging means for supporting the upper roller and feed roller.

20. In a machine of the character described, a supporting structure, a source of light connected therewith, a printing plate

disposed near the source of light, paper feeding means to coöperate with said printing plate, including upper and lower rollers and an endless belt trained thereabout, a feed roller disposed near the upper roller, a guide member disposed near said upper roller, and common swinging means for supporting the upper roller, feed roller, and guide member.

21. In a machine of the character described, a supporting structure, a source of light, a printing plate arranged to coöperate therewith, paper feeding means to coöperate with said printing plate, including upper and lower rollers and an endless belt trained thereabout, a feed roller disposed near the upper roller, common swinging means for supporting the upper roller and feed roller, and a weight adjustably connected with said swinging means.

In testimony whereof I affix my signature in presence of two witnesses.

CHARLES F. PEASE.

Witnesses:

J. T. HANNA,
S. C. LARSON.