



US00D725768S

(12) **United States Design Patent**  
**Eustis et al.**

(10) **Patent No.:** **US D725,768 S**

(45) **Date of Patent:** **\*\* Mar. 31, 2015**

(54) **FLOW GENERATOR**

(71) Applicant: **Human Design Medical, LLC**, Boston, MA (US)

(72) Inventors: **Thomas Eustis**, Arden, NC (US); **Kevin Scott Librett**, Watertown, MA (US)

(73) Assignee: **Human Design Medical, LLC**, Charlottesville, VA (US)

(\*\*) Term: **14 Years**

(21) Appl. No.: **29/472,662**

(22) Filed: **Nov. 14, 2013**

(51) **LOC (10) Cl.** ..... **24-01**

(52) **U.S. Cl.**  
USPC ..... **24/108; D24/165**

(58) **Field of Classification Search**  
CPC ..... A61B 5/0452; Y10S 128/901; A61M 16/0003; A61M 16/0066; A61M 16/0051; A61M 2205/42; A61M 2016/0027  
USPC ..... D24/108–110.6, 111, 113, 164–166  
See application file for complete search history.

(56) **References Cited**

**U.S. PATENT DOCUMENTS**

D564,087	S	*	3/2008	Yodfat et al.	.....	D24/108
D684,685	S	*	6/2013	Schneider et al.	.....	D24/111
D684,686	S	*	6/2013	Cronenberg	.....	D24/111
D685,083	S	*	6/2013	Schneider et al.	.....	D24/108
D685,084	S	*	6/2013	Guarraia et al.	.....	D24/108
D687,140	S	*	7/2013	Guarraia et al.	.....	D24/108
D695,392	S	*	12/2013	Tani	.....	D24/113
2007/0239058	A1	*	10/2007	Krasilchikov et al.	.....	600/538
2011/0180068	A1	*	7/2011	Kenyon et al.	.....	128/203.26

2012/0145155	A1	*	6/2012	Peake et al.	.....	128/205.12
2013/0066301	A1	*	3/2013	Locke et al.	.....	604/543
2013/0255689	A1	*	10/2013	Kim et al.	.....	128/205.24
2014/0290658	A1	*	10/2014	Schindhelm et al.	.....	128/204.23

\* cited by examiner

*Primary Examiner* — Antoine D Davis

(74) *Attorney, Agent, or Firm* — Raymond I. Bruttomesso, Jr.

(57) **CLAIM**

The ornamental design for a flow generator, as shown and described.

**DESCRIPTION**

FIG. 1 is a front perspective view of a flow generator illustrating the Applicants' new design;  
 FIG. 2 is a front view of the flow generator;  
 FIG. 3 is a right view of the flow generator;  
 FIG. 4 is a top view of the flow generator;  
 FIG. 5 is a back view of the flow generator;  
 FIG. 6 is a left view of the flow generator; and  
 FIG. 7 is a bottom view of the flow generator.  
 FIG. 8 is a front perspective view of another embodiment of a flow generator in accordance with present invention;  
 FIG. 9 is a front view of the flow generator in FIG. 8;  
 FIG. 10 is a right view of the flow generator;  
 FIG. 11 is a top view of the flow generator;  
 FIG. 12 is a back view of the flow generator;  
 FIG. 13 is a left view of the flow generator; and,  
 FIG. 14 is a bottom view of the flow generator.  
 Where included, the use of stippling is intended to denote a difference in materials.  
 The broken lines shown in the figures represent portions of a flow generator that form no part of the claimed design.

**1 Claim, 14 Drawing Sheets**

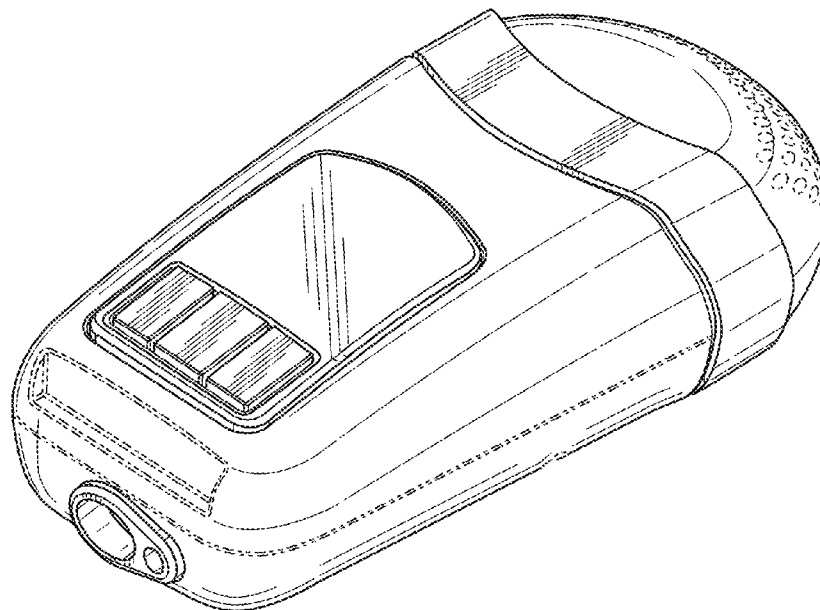

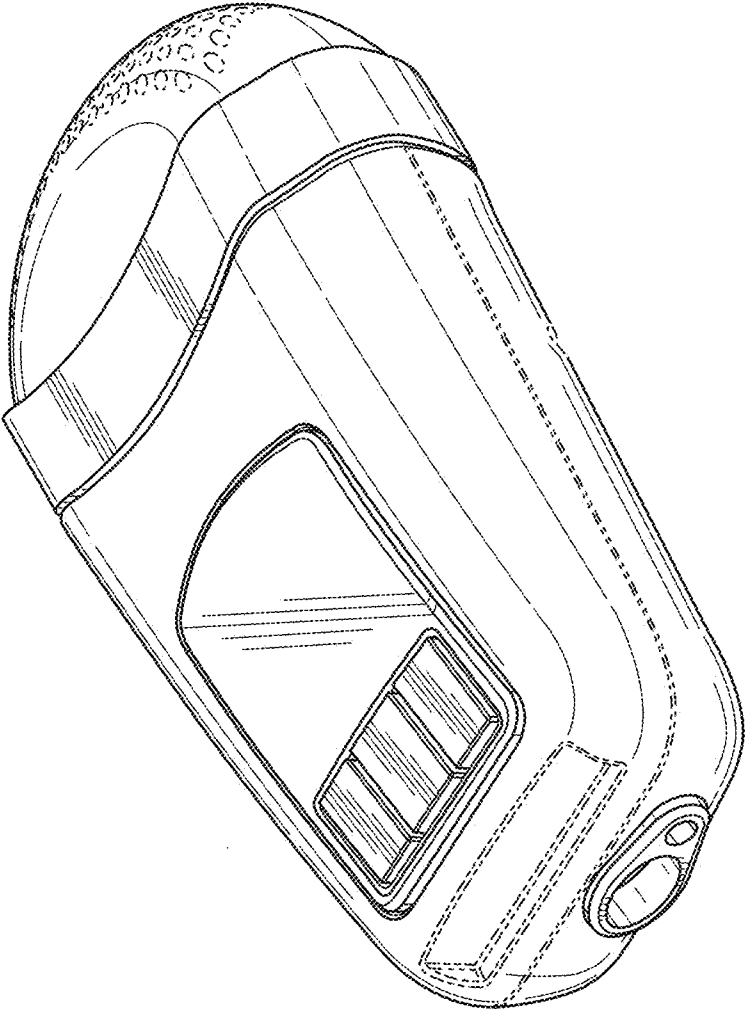

FIG. 1

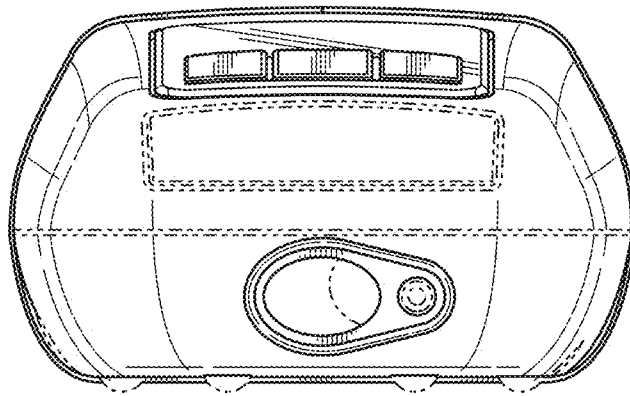

FIG. 2

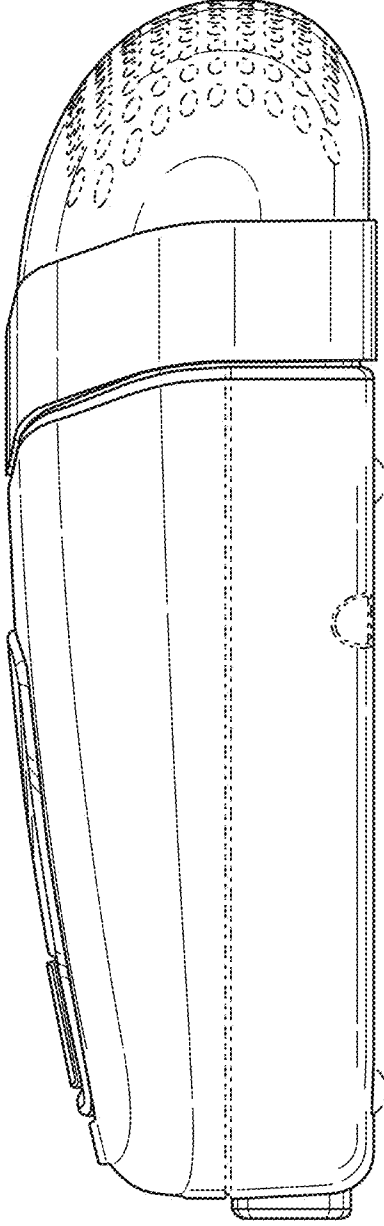

FIG. 3

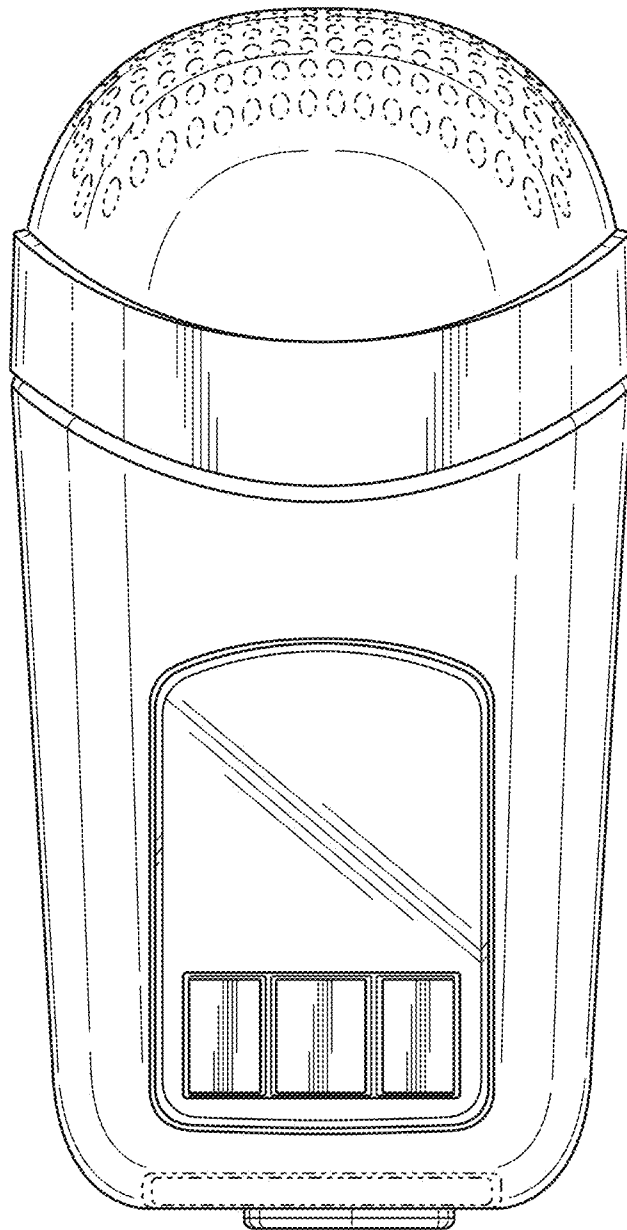

FIG. 4

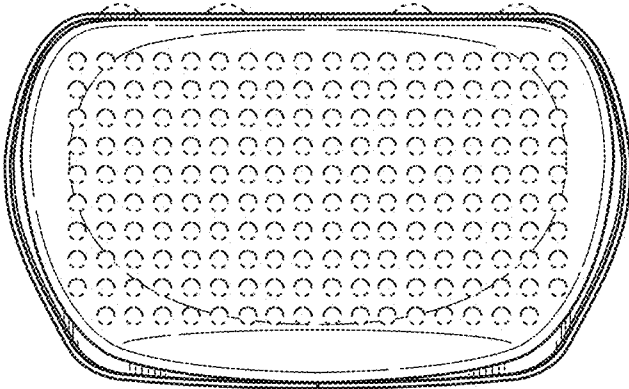

FIG. 5

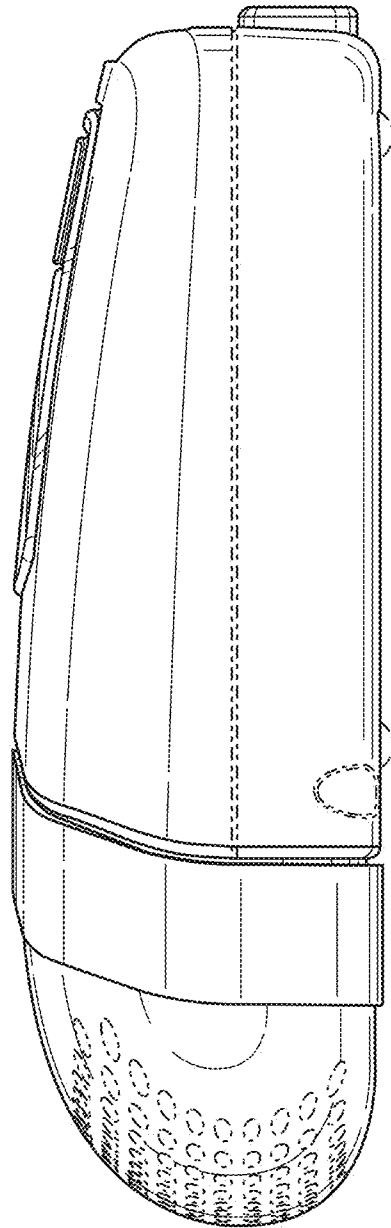

FIG. 6

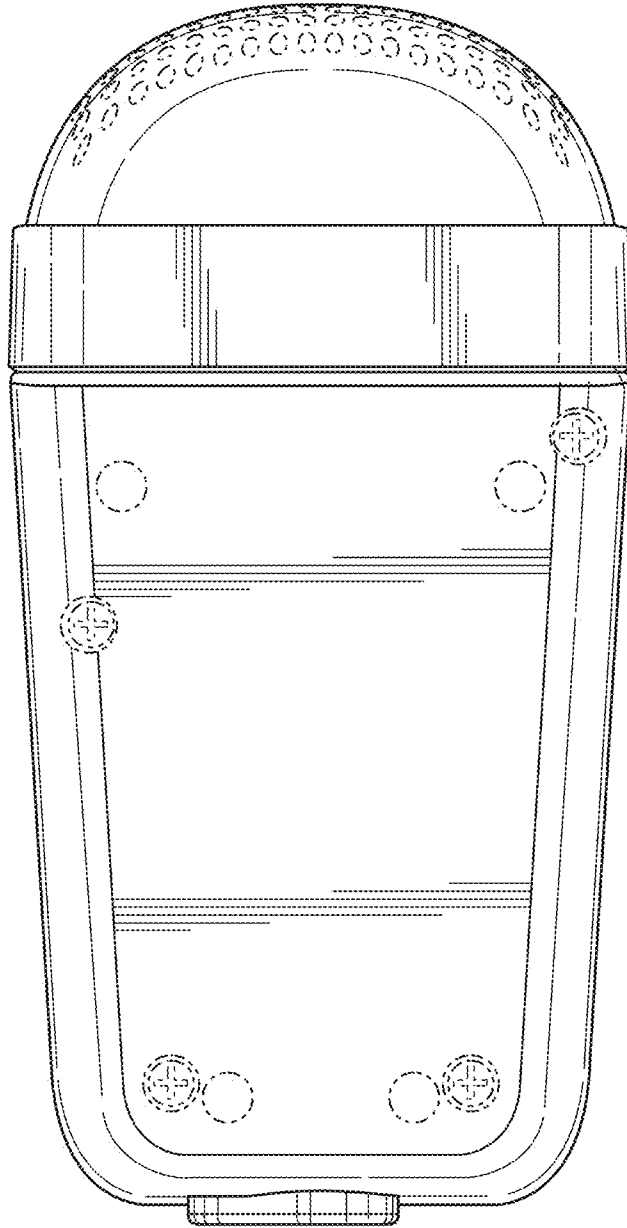

FIG. 7

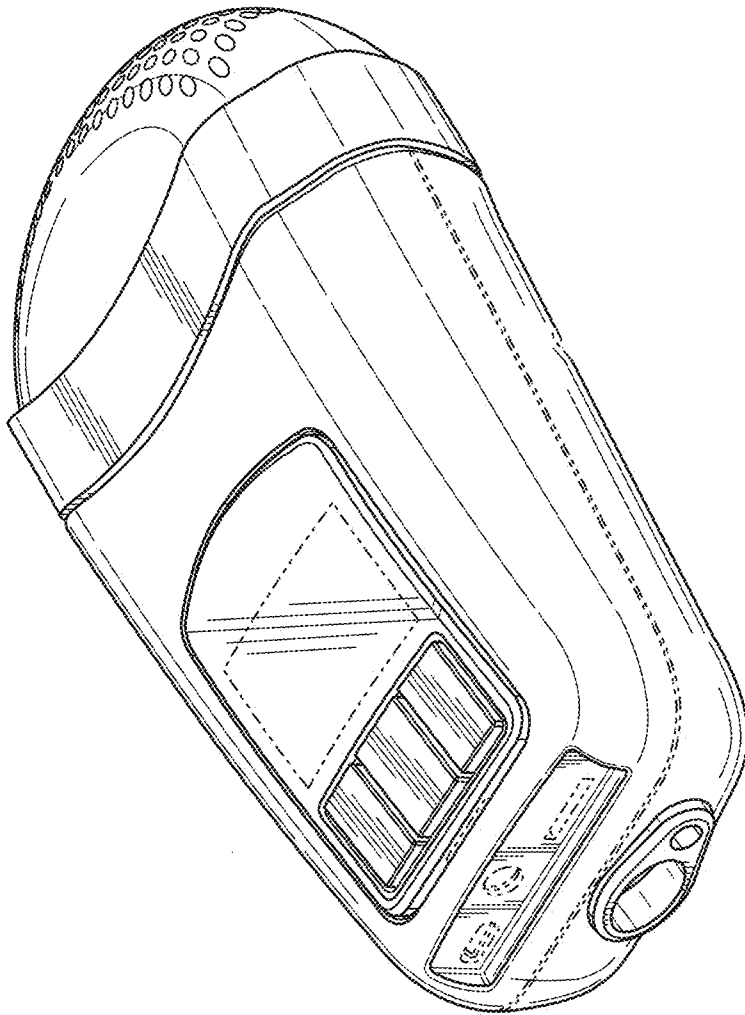

FIG. 8

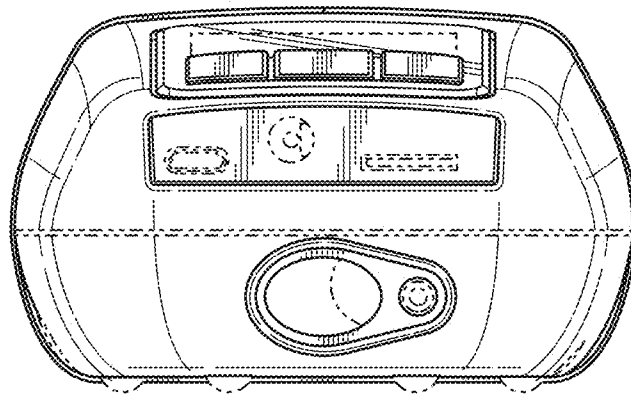

FIG. 9

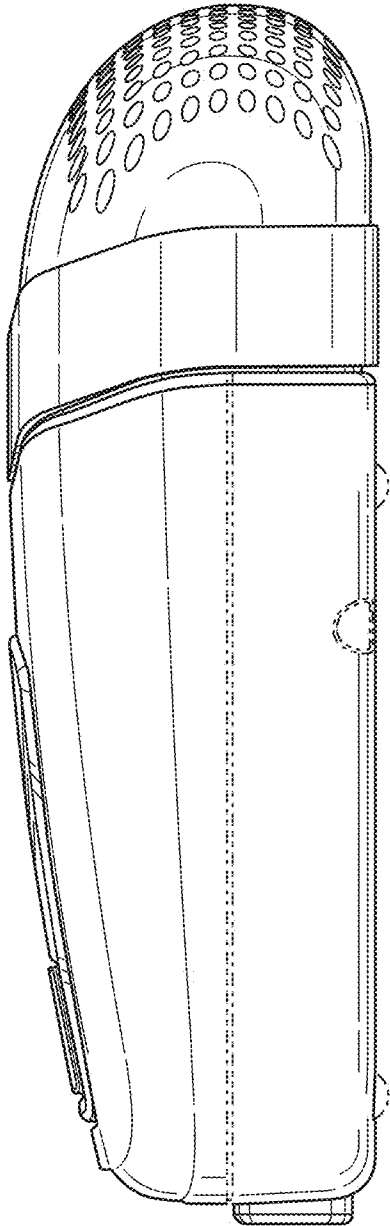

FIG. 10

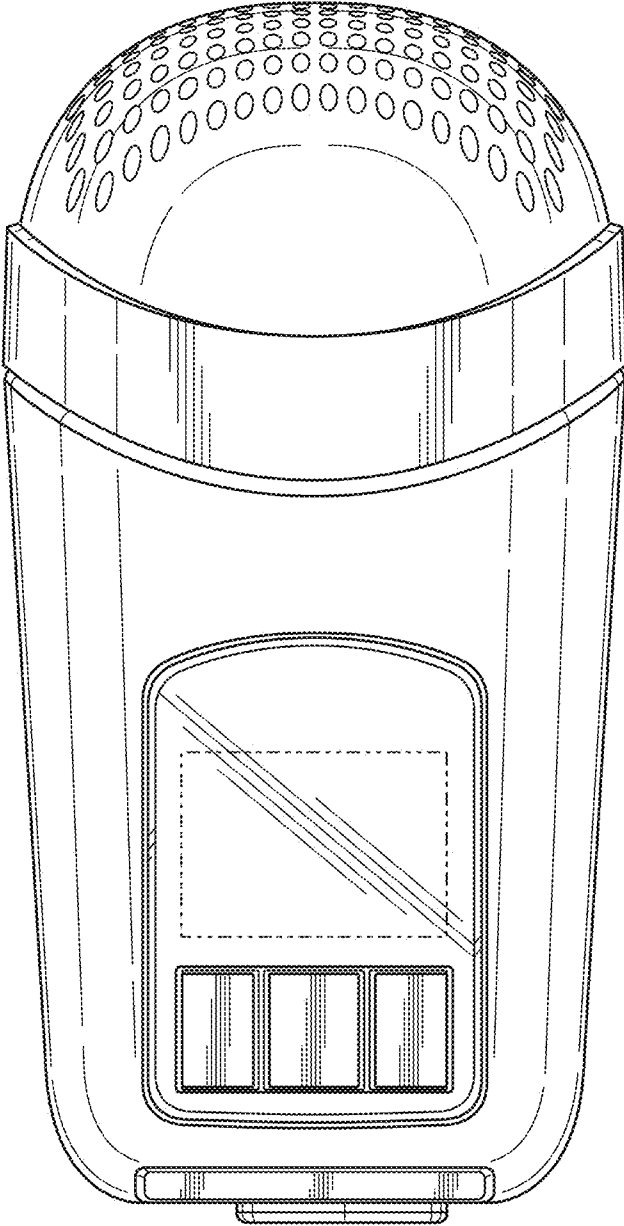

FIG. 11

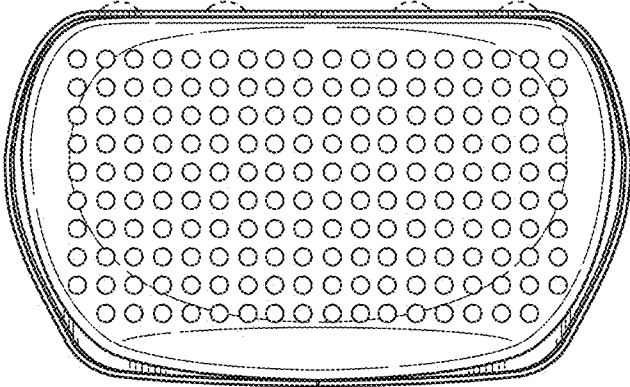

FIG. 12

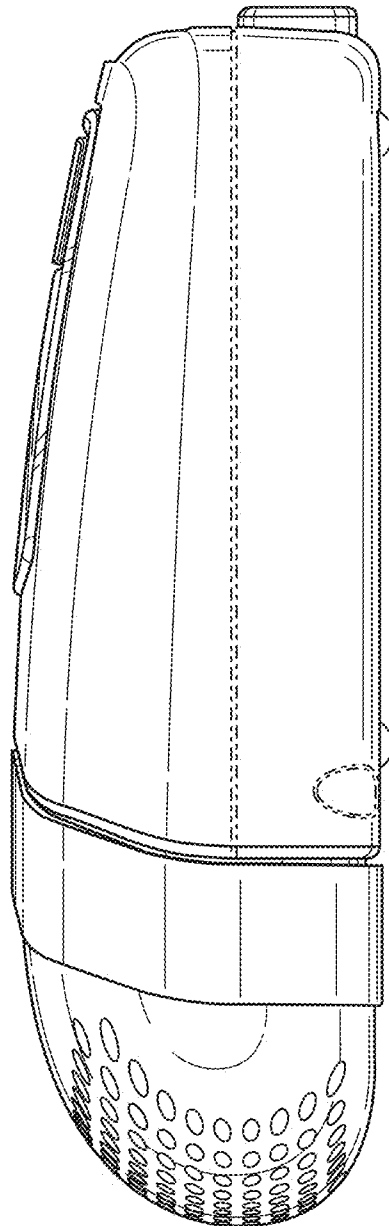

FIG. 13

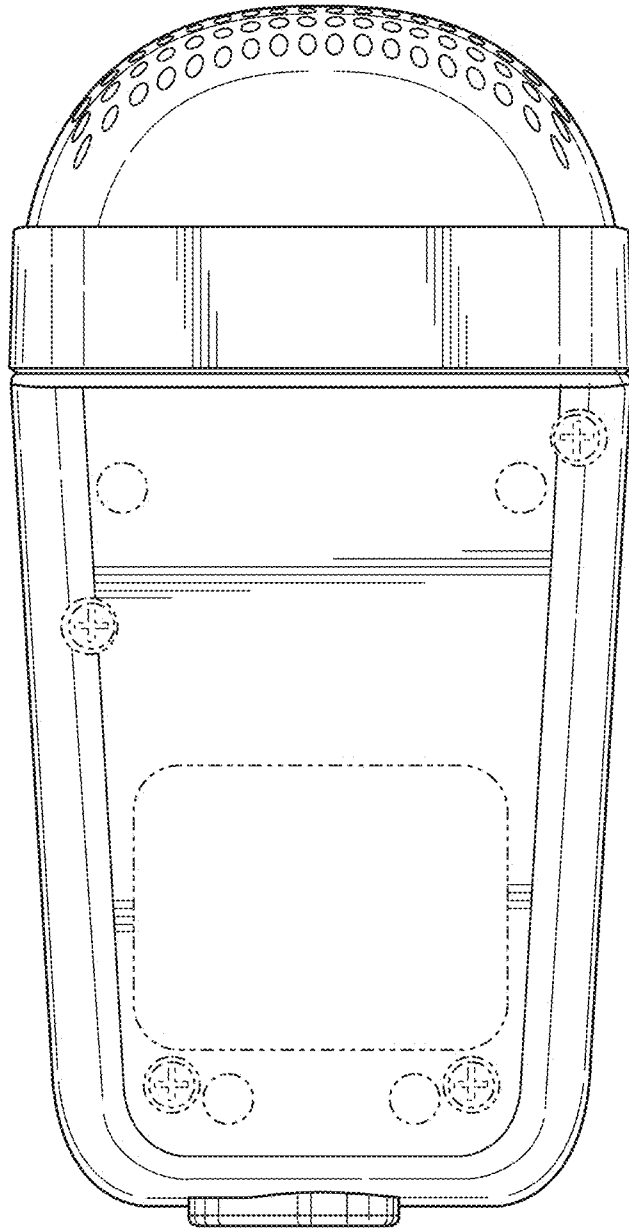

FIG. 14