

INTERNATIONAL APPLICATION PUBLISHED UNDER THE PATENT COOPERATION TREATY (PCT)

<p>(51) International Patent Classification ⁶ : A61F 13/15</p>	<p>A1</p>	<p>(11) International Publication Number: WO 98/24389</p> <p>(43) International Publication Date: 11 June 1998 (11.06.98)</p>
<p>(21) International Application Number: PCT/SE97/01954</p> <p>(22) International Filing Date: 21 November 1997 (21.11.97)</p> <p>(30) Priority Data: 9604480-5 5 December 1996 (05.12.96) SE</p> <p>(71) Applicant (for all designated States except US): SCA MÖLNLYCKE AB [SE/SE]; S-405 03 Göteborg (SE).</p> <p>(72) Inventors; and (75) Inventors/Applicants (for US only): HAGRUD, Ulrika [SE/SE]; Dr. Saléns gata 19, S-413 22 Göteborg (SE). LJUNGGREN, Per [SE/SE]; Starvägen 4, Anneberg, S-434 96 Kungsbacka (SE). NILSSON, Urban [SE/SE]; Pl 3972 Veneröd, S-442 95 Kungälv (SE).</p> <p>(74) Agents: GRAUDUMS, Valdis et al.; Albihn West AB, P.O. Box 142, S-401 22 Göteborg (SE).</p>		<p>(81) Designated States: AL, AM, AT, AU, AZ, BA, BB, BG, BR, BY, CA, CH, CN, CU, CZ, DE, DK, EE, ES, FI, GB, GE, GH, HU, ID, IL, IS, JP, KE, KG, KP, KR, KZ, LC, LK, LR, LS, LT, LU, LV, MD, MG, MK, MN, MW, MX, NO, NZ, PL, PT, RO, RU, SD, SE, SG, SI, SK, SL, TJ, TM, TR, TT, UA, UG, US, UZ, VN, YU, ZW, ARIPO patent (GH, KE, LS, MW, SD, SZ, UG, ZW), Eurasian patent (AM, AZ, BY, KG, KZ, MD, RU, TJ, TM), European patent (AT, BE, CH, DE, DK, ES, FI, FR, GB, GR, IE, IT, LU, MC, NL, PT, SE), OAPI patent (BF, BJ, CF, CG, CI, CM, GA, GN, ML, MR, NE, SN, TD, TG).</p> <p>Published <i>With international search report.</i></p>

(54) Title: ABSORBENT ARTICLE WITH IMPROVED LEAKAGE SECURITY

(57) Abstract

The invention relates to an absorbent article (1), intended for absorption of body fluids, having a longitudinal direction and a transverse direction and exhibiting a liquid-pervious surface (2), a liquid-impervious surface (3), and an absorbent body (4) arranged between the two surfaces (2, 3), and further exhibiting two longitudinal side edges (12, 13) extending in the longitudinal direction of the article and two transverse end edges (10, 11) extending in the transverse direction of the article. A number of air-filled channels (18), or material folds, are arranged on and projecting from the liquid-pervious surface (2) parallel to each other at least along one of the edges (12, 13; 40) of the article. The invention also relates to a method of manufacturing a laminate with air-filled channels.

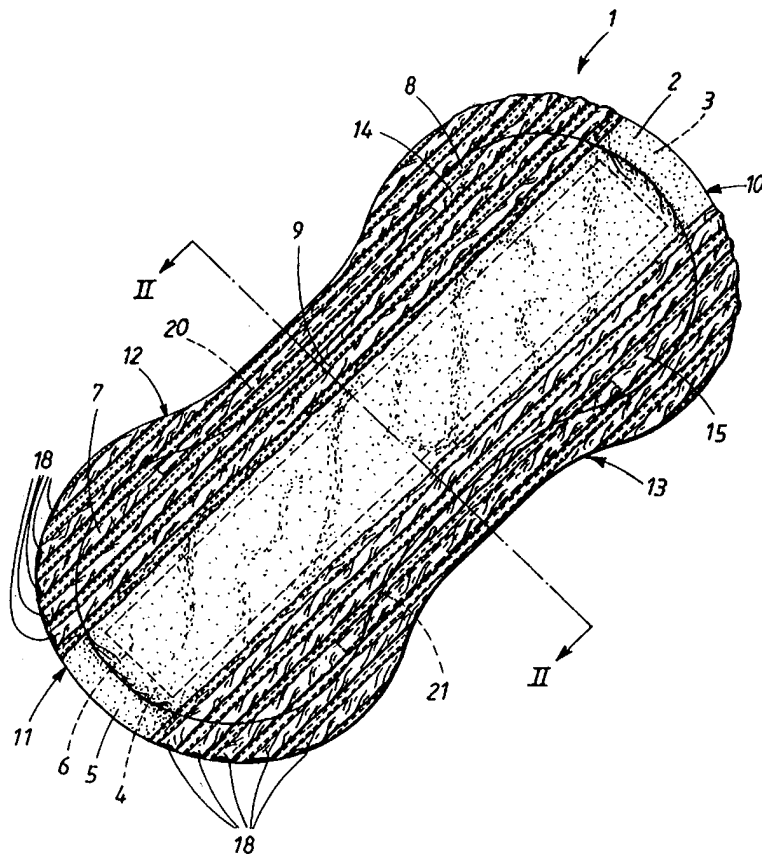

FOR THE PURPOSES OF INFORMATION ONLY

Codes used to identify States party to the PCT on the front pages of pamphlets publishing international applications under the PCT.

AL	Albania	ES	Spain	LS	Lesotho	SI	Slovenia
AM	Armenia	FI	Finland	LT	Lithuania	SK	Slovakia
AT	Austria	FR	France	LU	Luxembourg	SN	Senegal
AU	Australia	GA	Gabon	LV	Latvia	SZ	Swaziland
AZ	Azerbaijan	GB	United Kingdom	MC	Monaco	TD	Chad
BA	Bosnia and Herzegovina	GE	Georgia	MD	Republic of Moldova	TG	Togo
BB	Barbados	GH	Ghana	MG	Madagascar	TJ	Tajikistan
BE	Belgium	GN	Guinea	MK	The former Yugoslav Republic of Macedonia	TM	Turkmenistan
BF	Burkina Faso	GR	Greece			TR	Turkey
BG	Bulgaria	HU	Hungary	ML	Mali	TT	Trinidad and Tobago
BJ	Benin	IE	Ireland	MN	Mongolia	UA	Ukraine
BR	Brazil	IL	Israel	MR	Mauritania	UG	Uganda
BY	Belarus	IS	Iceland	MW	Malawi	US	United States of America
CA	Canada	IT	Italy	MX	Mexico	UZ	Uzbekistan
CF	Central African Republic	JP	Japan	NE	Niger	VN	Viet Nam
CG	Congo	KE	Kenya	NL	Netherlands	YU	Yugoslavia
CH	Switzerland	KG	Kyrgyzstan	NO	Norway	ZW	Zimbabwe
CI	Côte d'Ivoire	KP	Democratic People's Republic of Korea	NZ	New Zealand		
CM	Cameroon		Republic of Korea	PL	Poland		
CN	China	KR	Republic of Korea	PT	Portugal		
CU	Cuba	KZ	Kazakstan	RO	Romania		
CZ	Czech Republic	LC	Saint Lucia	RU	Russian Federation		
DE	Germany	LI	Liechtenstein	SD	Sudan		
DK	Denmark	LK	Sri Lanka	SE	Sweden		
EE	Estonia	LR	Liberia	SG	Singapore		

5 ABSORBENT ARTICLE WITH IMPROVED LEAKAGE SECURITY

TECHNICAL FIELD:

10 The invention pertains to an absorbent article intended for
absorption of body fluids, having a longitudinal direction
and a transverse direction and exhibiting a liquid-pervious
surface, a liquid-impervious surface, and an absorbent body
arranged between the two surfaces, and further exhibiting
15 two longitudinal side edges extending in the longitudinal
direction of the article and two transverse side edges
extending in the transverse direction of the article. The
invention also relates to a method of manufacturing a
material laminate from two material webs.

20 BACKGROUND OF THE INVENTION:

A large problem in connection with absorbent articles, such
as for example incontinence protectors for mildly
incontinent adults, is to achieve an article which is able
25 to receive large quantities of body fluid during a short
period of time without leaking. Above all, there is a large
risk with such articles that the liquid is not immediately
absorbed into the article but instead runs on the surface
of the article and flows out past the longitudinal side
30 edges of the article.

In order to avoid the problem with edge leakage, a number
of different solutions have been proposed. For instance, it
is previously known from SE 9401681-5 to arrange raised
35 barriers along the side edges of an absorbent article. Such
edge barriers, however, are comparatively complicated and
therefore expensive to manufacture, and cannot be combined
with the arrangement of elastic members along the side
edges of the article.

40

A number of further types of side edge barriers are previously known, for example from EP 0 219 326 and SE 9402337-1. These have in common that they are afflicted with disadvantages, for instance, by being of such a complicated construction that they are difficult and expensive to manufacture. Other disadvantages associated with previously known leakage barriers are that they often form hard, chafing edges and therefore cause discomfort to a user of an article provided with such a leakage barrier. Furthermore, a sufficient leakage protection is not achieved with several of the previously known leakage barriers.

Accordingly, there is a great need for an absorbent article with an improved protection against side edge leakage.

SUMMARY OF THE INVENTION:

Where an absorbent article of the type mentioned in the introduction is concerned, however, it is possible to achieve a considerably increased leakage security in accordance with the invention. It is further possible to obtain an absorbent article having soft, skin-friendly edge portions, also in such articles which are provided with elastic members along the side edges.

Thereby, an article in accordance with the invention is primarily characterized in that a number of air-filled material folds are arranged on and projecting from the liquid-pervious surface at least at one of the edges of the article.

Thereby, the material folds may be regularly or irregularly arranged across the material surface, and may vary in shape and size.

In one advantageous embodiment, a number of air-filled, substantially parallel material folds are arranged in the longitudinal direction of the article, inside each side edge. Thereby, it is suitable that the number of material folds is between 4 and 10 along each side edge.

By means of the invention, a number of advantages are obtained. Since the air-filled material folds are slightly raised from the liquid-pervious surface of the article, they constitute an effective protection against liquid flow on the liquid-pervious surface. If the material folds are arranged in the longitudinal direction of the article, they serve as barriers, arranged outside one another, against liquid spreading in the transverse direction of the article and thereby prevent liquid from flowing freely across the surface and out past the side edges of the article. In a corresponding way, the spreading of liquid out past the end edges of the article is prevented by means of material folds arranged in the transverse direction of the article at the end edges.

Furthermore, the channels reduce the contact surface between the article and the body of the user, as a result of which the article is perceived as fluffy and comfortable to wear. A further advantage is that the air-filled material folds are soft and slightly resilient and in this way enhance the comfort to the user and reduce the risk of chafing during use. The enhanced comfort is particularly evident when the article is provided with elastic members along the side edges or, when applicable, at a waist edge formed by the end edges. Thereby, the air-filled material folds hide the elastic members, at the same time as they constitute a soft filling against the body of the user.

Even if it is suitable from a leakage-security point of view to arrange the material folds substantially parallel

to the edges of the article, it has no decisive significance from a comfort point of view how the material folds are oriented. Accordingly, if increased comfort to the user is what is primarily aimed at, it is conceivable
5 to arrange material folds substantially perpendicularly to the edges of the article. There may be advantages from a designing or manufacturing point of view with such a design of an absorbent article. Furthermore, it is of course possible to arrange the material folds obliquely to the
10 edge, as well as to use a barrier material having an irregularly wrinkled surface.

The distance between the air-filled channels, and their height above the surface of the article may be varied in
15 order to achieve the best possible leakage protection and, at the same time, an article that is as comfortable as possible. Furthermore, the number of channels may of course be varied. Where incontinence protectors for mildly incontinent persons are concerned, it has been found to be
20 suitable to arrange the channels at a mutual distance of between 2 and 7 mm. The height of the channels above the surface of the incontinence protector should thereby be between 0.2 and 3 mm. The width of the channels is suitably between 2 and 6 mm and depending on the size of the
25 channels between 2 and 15 channels can be arranged along each side edge of the absorbent article.

According to one embodiment of the invention, longitudinal strips of a material laminate, comprising a first material
30 layer and a second material layer, are arranged along each side edge of the article whereby the air-filled channels are arranged between the two material layers in the longitudinal strips.

35 According to another embodiment of the invention, elastic members are arranged along the longitudinal side edges of

the article, whereby the elastic members are arranged inside the air-filled channels, seen in a direction from the liquid-pervious surface towards the liquid-impervious surface.

5

It is not necessary for the invention that the air-filled channels or material folds are created in a special material laminate. For instance, it is possible to create channels between a liquid-pervious cover layer and a material layer situated outside this. It is further possible to arrange the air-filled channels between the absorbent body and the liquid-pervious cover layer. Such an embodiment, however, requires that the absorbent body has a sufficiently high cohesive ability in order to make it possible to laminate the cover layer together with the absorbent body and thereby obtain channels which do not collapse during use. Suitable absorbent bodies for the purpose are those which consist of absorbent nonwoven materials, absorbent foam layers, bonded layers of absorbent fibre wadding, or the like.

10

15

20

BRIEF DESCRIPTION OF THE DRAWINGS:

25

In the following, the invention will be described in greater detail with reference to the embodiments shown in the attached drawings, wherein

30

Fig. 1 shows a plan view of an incontinence protector according to the invention, seen from the side which is facing towards the user during use;

Fig. 2 shows a section along the line II-II through the incontinence protector in Fig. 1;

- Fig. 3 shows a plan view of a diaper according to the invention, seen from the side which is facing towards the user during use;
- 5 Fig. 4 shows a welding cylinder with guiding fingers for shaping a material layer according to the surface of the welding cylinder;
- 10 Fig. 5 shows a longitudinal section through a part of the welding cylinder in Fig. 4 together with two material layers;
- Fig. 6 shows a schematic illustration of a manufacturing process according to the invention;
- 15 Fig. 7 shows an enlarged part of the manufacturing process shown in Fig. 6;
- Fig. 8 shows a material laminate out of which edge barriers according to the invention may be formed, and
- 20 Fig. 9 shows another material laminate for the formation of edge barriers.

25

DETAILED DESCRIPTION OF EMBODIMENTS:

The incontinence protector 1 shown in Figs. 1 and 2 comprises a liquid-pervious cover layer 2, a liquid-impervious cover layer 3, and an absorbent body 4 enclosed between the cover layers 2, 3. The liquid-pervious cover layer 2 consists of, for example, a layer of nonwoven fibre fabric, so-called nonwoven material, or of a perforated plastic film, a scrim material, or the like. The liquid-impervious cover layer 3 may consist of a liquid-impervious plastic film, a nonwoven layer which has been coated with

30

35

a liquid barrier material, or any other easily pliable material layer which has the ability to withstand liquid penetration. As a rule, it is an advantage if the liquid-impervious cover layer 3 exhibits a certain breathability, i.e. allows passage of water vapour through the layer 3. The two cover layers 2, 3 have a somewhat larger extension in the plane than the absorbent body 4 and extend a distance out past the absorbent body 4 around its entire periphery. The cover layers 2, 3 are mutually connected within the projecting portions 5, for example by means of gluing or welding with heat or ultrasonics.

The absorbent body 4 may be of any type which is suitable for the purpose. Examples of frequently occurring absorption materials are cellulose fluff pulp, tissue layers, highly absorbent polymers, absorbent foam materials, absorbent nonwoven materials and the like. Material mixtures and absorbent bodies built up from materials of different types and with different properties also occur.

On the outside of the liquid-impervious cover layer 3 an attachment member 6 in the form of a longitudinal region of self-adhesive glue is arranged. Before use, the attachment member 6 is suitably covered by a removable protective layer, not shown in the drawing, made of paper treated with release agent, plastic film, or the like. Instead of the shown glue pattern, in the form of a longitudinal glue region, a number of other glue patterns may be used, such as transverse bands, dots, complete coverage etc. Alternatively, other types of attachment means may be utilized, such as hook and loop fastener surfaces, snap fasteners, girdles, special underpants, or the like.

An incontinence protector 1 of the kind shown in Fig. 1 is primarily intended to be used by persons with relatively

mild incontinence troubles and therefore has such a size that it easily can be accommodated inside a pair of normal underpants. Thereby, the attachment member 6 serves to keep the incontinence protector in its place inside the
5 underpants.

The incontinence protector 1 is primarily hourglass-shaped, having wider end portions 7, 8 and a narrower crotch portion 9, located between the end portions 7, 8. The
10 crotch portion 9 is the portion of the incontinence protector 1 which is intended to be applied in the crotch of the user during use and to serve as a reception area for the body fluid which is excreted to the incontinence protector 1. Furthermore, the incontinence protector 1
15 exhibits two transverse, rounded end edges 10, 11, and two longitudinal, curved side edges 12, 13 extending between the end edges 10, 11.

The incontinence protector 1 further exhibits a material strip 14, 15 arranged along each longitudinal side edge. The material strips 14, 15 extend from each respective side edge 12, 13 in across the liquid-pervious cover layer 2 approximately one fourth of the width of the incontinence protector 1 at the crotch portion 9.
20

The material strips 14, 15 consist of a material laminate comprising two layers 16, 17 of nonwoven material, which have been joined in such a way that air-filled channels 18, or material folds, have been created between the nonwoven
30 layers 16, 17. The material strips 14, 15 are arranged on the liquid-pervious cover layer 2 with the air-filled channels 18 extending in the longitudinal direction of the incontinence protector 1. In order to anchor the material strips 14, 15 on the incontinence protector 1, these are
35 bonded to the liquid-pervious cover layer 2, for example by means of gluing, or welding with heat or ultrasonics. It is

suitable that the joint between the material strips 14, 15 and the cover layer 2 is carried out in such a way that liquid may pass in to the absorbent body 4 also within the area of the material strips 14, 15.

5

Longitudinal elastic members 20, 21 are arranged along the two side edges 12, 13 of the incontinence protector. The elastic members 20, 21 are applied under pre-tension and attached between the liquid-pervious cover layer 2 and the liquid-impervious cover layer 3 in the projecting portions 5 of the cover layers 2, 3 at the crotch portion 9 of the incontinence protector. The elastic members 20, 21 may be of any type which is suitable for the purpose, and may consequently be constituted by elastic bands, threads, scrims, or the like.

10
15

The elastic members 20, 21 curve the incontinence protector 1 longitudinally, so that a better adaptation to the body shape of the user is achieved. Furthermore, the elastic members 20, 21 constitute a protection against edge leakage since they raise the projecting portions 5 of the two cover layers 2, 3 in a direction towards the liquid-pervious cover layer 2 of the incontinence protector. Thus, liquid-absorbing ditches are formed on both sides of the absorbent body 4, between the absorbent body and the elastic members 20, 21.

20

25

When arranging elastic members along the side edges on an absorbent article of the shown type, the risk is great that sharp folds are formed in the cover material when the elastic members are contracted. Such folds may cause the user inconvenience by chafing and irritating the skin.

30

Where the incontinence protector in Figs. 1 and 2 is concerned, however, the risk of chafing and skin irritation is very small since the material strips 14, 15 along the

35

side edges 12, 13 form a fluffy padding over the elastic members 20, 21. The material strips 14, 15 create a distance between the elastic members 20, 21 and the body of the user and the air-filled channels 18 allow a certain
5 circulation of air and moisture. By means of this, the incontinence protector 1 is soft and comfortable to wear, and is perceived as being more pleasant and less warm and sweaty than conventional incontinence protectors.

10 The baby diaper 30 shown in Fig. 3 has the same fundamental structure as the incontinence protector in Figs. 1 and 2. Accordingly, the diaper exhibits a liquid-pervious cover layer 32 and a liquid-impervious cover layer 33, which together enclose an absorbent body 34 of conventional type.

15 The diaper 30 has an elongate shape, with wider front and back portions 35, 36 and a narrower crotch portion 37. The front portion 35 is the part of the diaper which is intended to be turned forwards on the user when the diaper
20 is used, and the back portion 36 is the part of the diaper which is turned backwards on the user. Furthermore, the diaper 30 has two longitudinal, concavely-curved side edges 38, 39 and a front edge 40 and a back edge 41.

25 The diaper 30 is of the type which during use is fastened together so that it encloses the lower portion of the trunk of the user in a pant-like way. For this purpose, a tape flap 42, 43 is arranged projecting from each side edge 38, 39, close to the back edge 41 of the diaper. The tape flaps
30 42, 43 are intended to interact with a reception area 44 arranged on the liquid-impervious cover layer 33, on the front portion 35 of the diaper 30. Such a reception area 44 suitably exhibits some kind of reinforcement, for example
35 applied onto the liquid-impervious cover layer 33. Naturally, it is alternatively conceivable to use other

types of fastening devices for the diaper 30, such as buttons and buttonholes, hooks and loops, snap fasteners, hook and loop fastenings or the like.

5 The diaper 30 is further provided with longitudinal elastic members 45, 46, applied under pre-tension, arranged in a substantially V-shaped pattern, with the tip of the V directed towards the front edge 40 of the diaper and the two legs directed towards the back edge 41 of the diaper.
10 The elastic members 45, 46 form the diaper 30 and constitute its leg elastics during the use of the diaper. By this means, the elastic members 45, 46 serve to keep the side edges 38, 39 of the diaper in contact against the legs of the user in order to prevent gaps, through which body
15 fluid may leak out of the diaper, from arising between the diaper and the body of the user during use.

In a corresponding way, an elastic member 47 is arranged along the back edge 41 of the diaper in order to achieve an
20 elastic sealing around the waist of the user.

A strip 48 of a material laminate formed out of two material layers is applied along the front edge 40 of the diaper. The material layers are mutually connected in such
25 a way that air-filled channels 50 are formed between the layers. The air-filled channels 50 extend in the transverse direction of the diaper 30, along the front edge 40. By means of this, the channels 50 constitute a plurality of barriers against liquid passage out past the front edge 40
30 of the diaper. Leakage of body fluid past the front edge 40 on a baby diaper is a common problem, particularly in connection with the baby lying on its stomach when asleep.

The material strip 48 advantageously consists of a laminate
35 of a liquid-impervious layer, for example a plastic film, and a nonwoven layer. The liquid-impervious layer is

arranged inside the nonwoven layer, closest to the liquid-
pervious cover layer 32. In this way a barrier is created
which prevents liquid which already has been absorbed into
the absorbent body 34 of the diaper from penetrating back
5 out from the diaper 30 at the front edge 40. The nonwoven
layer prevents contact between the skin of the user and the
liquid-impervious layer. Furthermore, the nonwoven layer is
pleated in the transverse direction of the diaper and
thereby forms the above mentioned fluffy channels 50 which
10 prevent liquid from flowing out past the front edge 40 on
the surface of the diaper.

Figs. 4-7 illustrate one way of achieving a material
laminate 60 which can be used for manufacturing leakage
preventing barriers in accordance with the invention.
15 During the manufacture, a laminate 60 is formed from a
first material web 61 and a second material web 62 by
feeding the two material webs 61, 62 in between a welding
cylinder 67 and an ultrasonic horn 68 in order to bond them
together. As shown in Fig. 4, the welding cylinder 67 has
20 a number of circular flanges 69, which serve as holding-up
tools for the ultrasonic horn 68 in the bonding process. In
the spaces 70 between the flanges 69, guiding fingers 71
are arranged. The first material web is fed towards the
welding cylinder 67, between this and the guiding fingers
25 71 so that the guiding fingers 71 press the material web 61
down into the spaces 70 between the flanges 69. In this
way, the material web 61 is pleated in the longitudinal
direction, as shown in cross-section in Fig. 5. After the
30 pleating of the first material web 61 this is brought
together with the second material web 62 and the two
material webs 61, 62 are bonded together by means of
ultrasonic bonding between the flanges 69 and the
ultrasonic horn 68.

In Fig. 6, the entire manufacturing process is schematically shown, whereas Fig. 7 shows a magnification of the joining step in the manufacturing process. The circular flanges 69 are shown in Fig. 7 as a plurality of
5 pegs 72, or protuberances, which implies that the joining of the two material webs 61, 62 takes place in an intermittent way. By means of feeding the first material web 61 with a speed which is somewhat higher than the speed of the second material web 62, more precisely with a speed
10 which is 101%-200% of the speed of the second material web 62, a pleating of the first material web 61 is obtained also in the transverse direction, as is evident from Fig. 7.

15 In Figs 8 and 9, pieces of material laminate 80, 90, manufactured according to the method described above, are shown.

The material web 80, shown in Fig. 8, consists of a first
20 material layer 81 and a second material layer 82. The two material layers 81, 82 are mutually connected by welds, arranged in the travel direction of the material web. The welds constitute dot-shaped bonds 84 arranged in double rows 85, alternating with intermediate longitudinal un-
25 bonded portions 86, which form raised material folds on the surface of the laminate 80.

Also the material laminate 90 shown in Fig. 9 exhibits a wrinkled surface and may be used for achieving a liquid
30 flow barrier on an absorbent article. The laminate is manufactured without using the guiding fingers described in connection with the manufacturing process. The degree of wrinkling is thereby determined by the relative speed with which the first material web 91 is fed forwards in relation
35 to the second material web 92, and by the bonding density and the bonding pattern.

Another way of manufacturing a material laminate, for example of the type which is shown in Fig. 8, is by stretching the second material layer 82 in the travel direction of the material web. Thereby, it is essential that the second material layer 82 exhibits a certain elasticity, so that it has the ability to completely or partially return to its original length when the stretching ceases. The two material layers 81, 82 are joined while the second material layer 82 is kept stretched out, whereafter the stretching stops and the second material layer 82 is allowed to contract. Thereby, the un-bonded portions 86 form air-filled, transverse material folds, or channels between the weld rows 85 in the material web 80, since the first material layer 81 is pleated when the material web which has been welded together contracts.

An alternative way of achieving the material laminate 80 shown in Fig.8 is by means of bonding the same two material layers 81, 82, which have been chosen so that one layer 82 shrinks more than the other layer 81 when the layers 81, 82 are subjected to shrink treatment, for example by means of heating. The material layers 81, 82 are bonded together along a number of separated bonding lines, whereafter the material web is shrink treated, so that the second material layer 82 contracts while the first material layer 81 is pleated.

It is of course possible to join the two material layers in another way than by the use of ultrasonics. Accordingly, it is for example possible to weld with heat, or to glue the layers together.

The invention should not be regarded as being limited by the herein described embodiments. Accordingly, the invention includes all types of articles intended for

absorption of body fluids and wherein an improved protection against edge leakage is desired.

5 It is further possible, within the scope of the claims, to conceive variants and combinations of the described embodiments.

10 In the described embodiments, the liquid-pervious surface of the articles, and their liquid-impervious surface, have been described as being separate material layers. Such an arrangement is however not necessary. Accordingly, it is conceivable that one or both cover layers constitute an integral part of the absorbent body of the article. An absorbent body of foam material, for instance, may be
15 formed with a skin-like, liquid-impervious surface which may serve as a liquid-impervious cover layer. In a corresponding way, an absorbent body of foam material or absorbent nonwoven material may have a liquid-pervious surface with suitable properties for being able to replace
20 a special, liquid-pervious cover layer.

5

CLAIMS:

1. Absorbent article (1), intended for absorption of body fluids, having a longitudinal direction and a transverse direction and exhibiting a liquid-pervious surface (2), a liquid-impervious surface (3), and an absorbent body (4) arranged between the two surfaces (2, 3), and further exhibiting two longitudinal side edges (12, 13) extending in the longitudinal direction of the article, and two transverse end edges (10, 11) extending in the transverse direction of the article, characterized in that a number of air-filled material folds (18) are arranged on and projecting from the liquid-pervious surface (2) at least at one of the edges (12, 13; 40) of the article.

2. Absorbent article according to claim 1, characterized in that the air-filled material folds (18) are substantially parallel and are arranged in the longitudinal direction of the article, inside each side edge (12, 13).

3. Absorbent article according to claim 2, characterized in that at least 2 and preferably between 4 and 10 channels (18) are arranged along each side edge (12, 13; 40).

4. Absorbent article according to any one of claims 1-3, characterized in that strips (14, 15) of a material laminate, comprising a first material layer (16) and a second material layer (17), are arranged along each side edge (12, 13) on the article, whereby the air-filled material folds (18) are arranged between the two material layers (16, 17) in the longitudinal strips (14, 15).

40

5. Absorbent article according to claim 1, characterized in that the air-filled material folds (18) are arranged in the transverse direction of the article inside each side edge (12, 13).

5

6. Absorbent article (30) according to claim 1, characterized in that a number of air-filled material folds (50), or channels, are arranged across the liquid-pervious surface (32) of the article along at least one of the end edges (40) of the article (30).

10

7. Absorbent article (30) according to claim 6, characterized in that the air-filled material folds (50) are substantially parallel and are arranged in the transverse direction of the article, inside the end edge (40).

15

8. Absorbent article according to any one of the preceding claims, characterized in that the material folds (18) are arranged at a mutual distance of 2-7 mm across their extension direction.

20

9. Absorbent article according to any one of the preceding claims, characterized in that the material folds (18) have a height above the liquid-pervious surface (2) of the article of 0.2-5 mm.

25

10. Absorbent article according to any one of the preceding claims, characterized in that the material folds (18) have a width of between 2 and 4 mm.

30

11. Absorbent article according to any one of the preceding claims, characterized in that elastic members (20, 21) are arranged along the longitudinal side edges (12, 13) of the article.

35

12. Method of manufacturing a material laminate for use in an absorbent article according to claim 1, whereby a first material web (61) and a second material web (62) are bonded together in an intermittent bonding pattern,

5 c h a r a c t e r i z e d i n that the first material web (61) is caused to pass over a bonding cylinder (67) provided with bonding surfaces (69) in the form of a number of, from the surface of the cylinder, annularly projecting flanges, or rows of protuberances with intermediate spaces
10 (70) in the form of annular grooves or sunk tracks, whereby the first material web (61) is caused to be formed according to the surface of the bonding cylinder (67) by guiding fingers (71) which press the first material web (61) into the intermediate spaces (70) between the bonding
15 surfaces (69), and that the second material web (62) is brought together with the first material web (61), whereafter the two material webs (61, 62) are bonded together at the bonding surfaces (69).

20 13. Method according to claim 12,
c h a r a c t e r i z e d i n that the bonding is done by means of ultrasonics.

14. Method according to claim 12 or 13,
25 c h a r a c t e r i z e d i n that the first material web (61) is fed forwards with a first speed and the second material web (62) is fed forward with a second speed whereby the first speed is 101%-200% of the second speed.

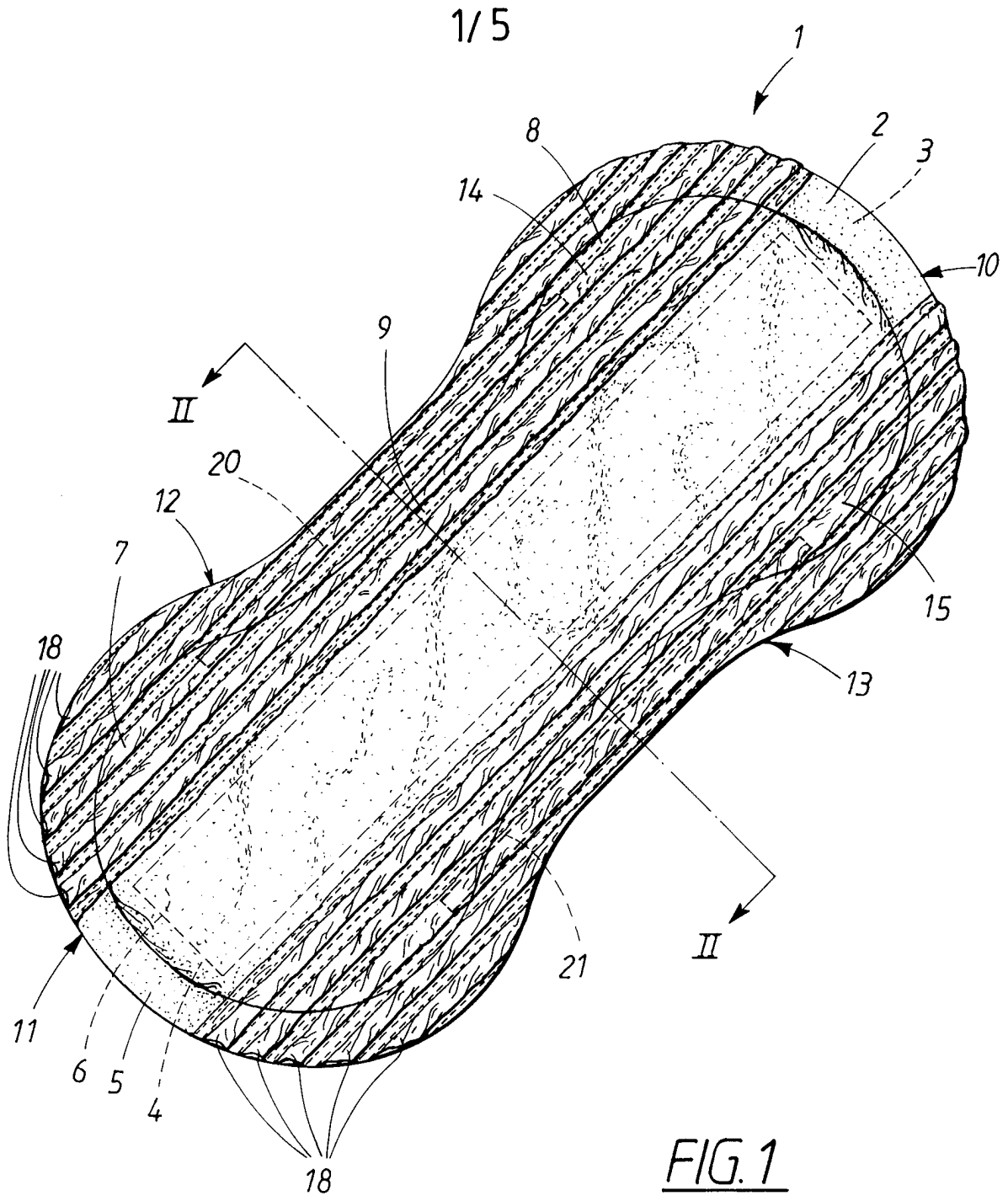

FIG. 1

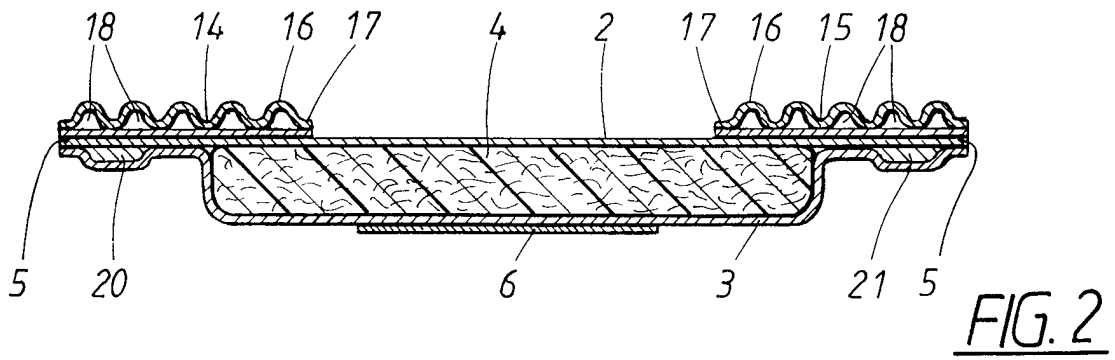

FIG. 2

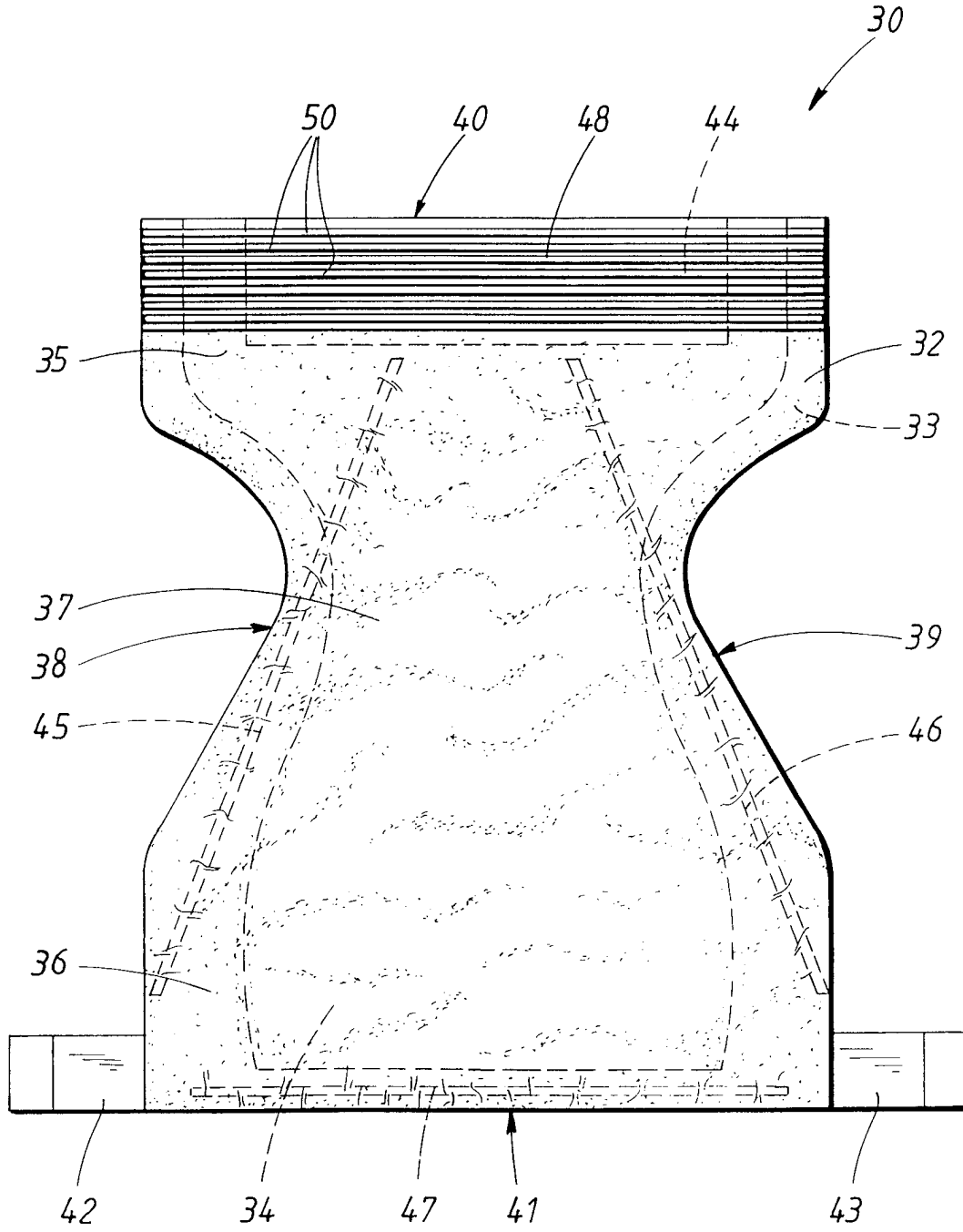

FIG. 3

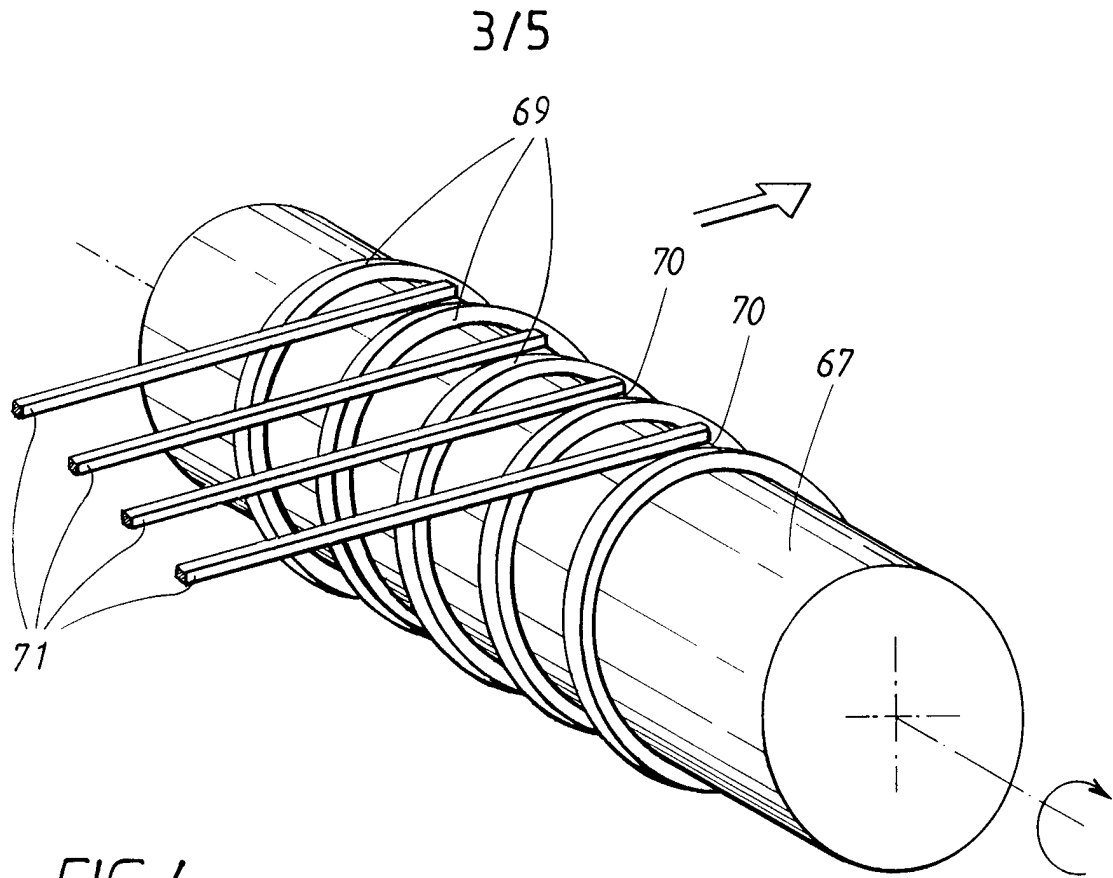

FIG. 4

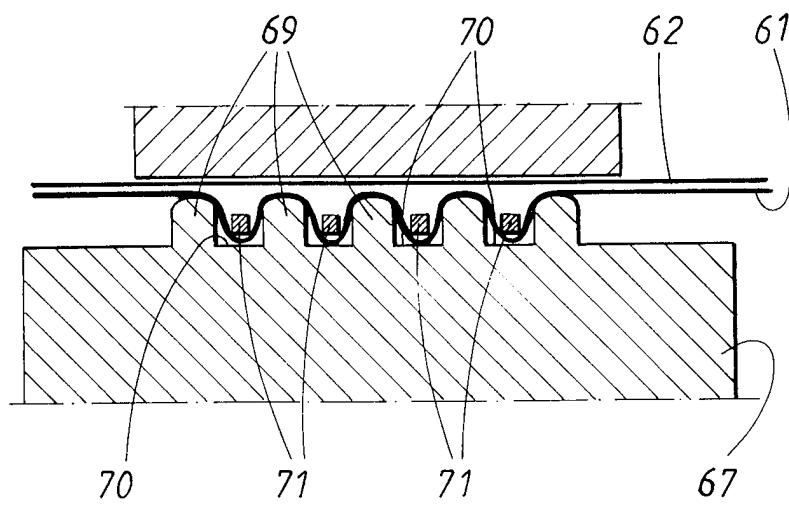

FIG. 5

4/5

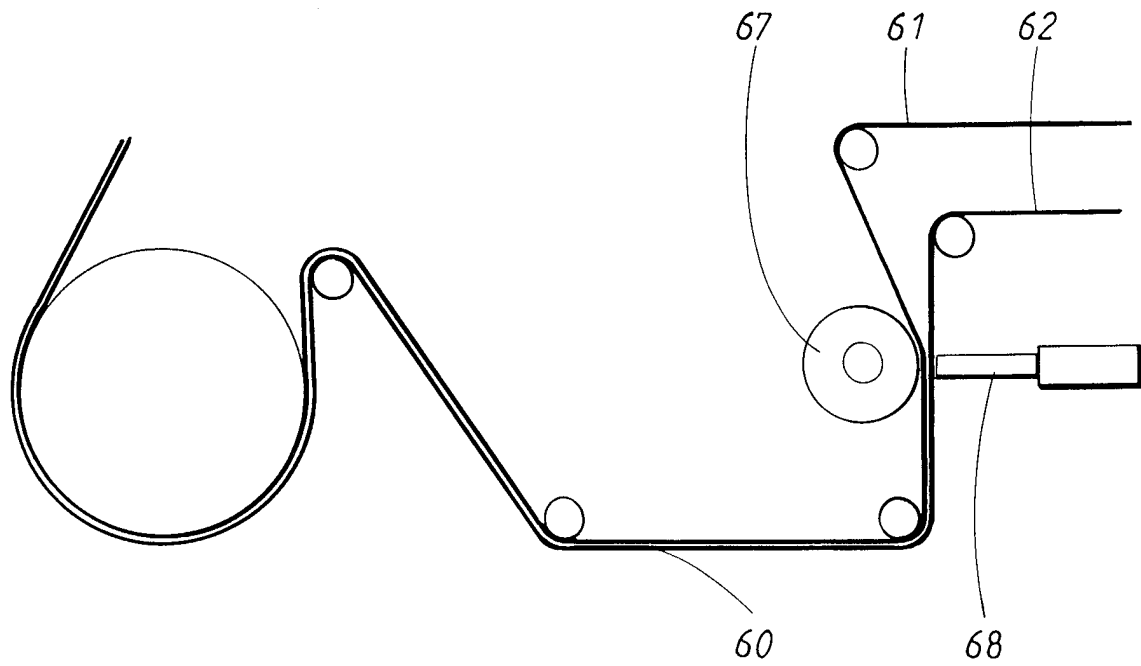

FIG. 6

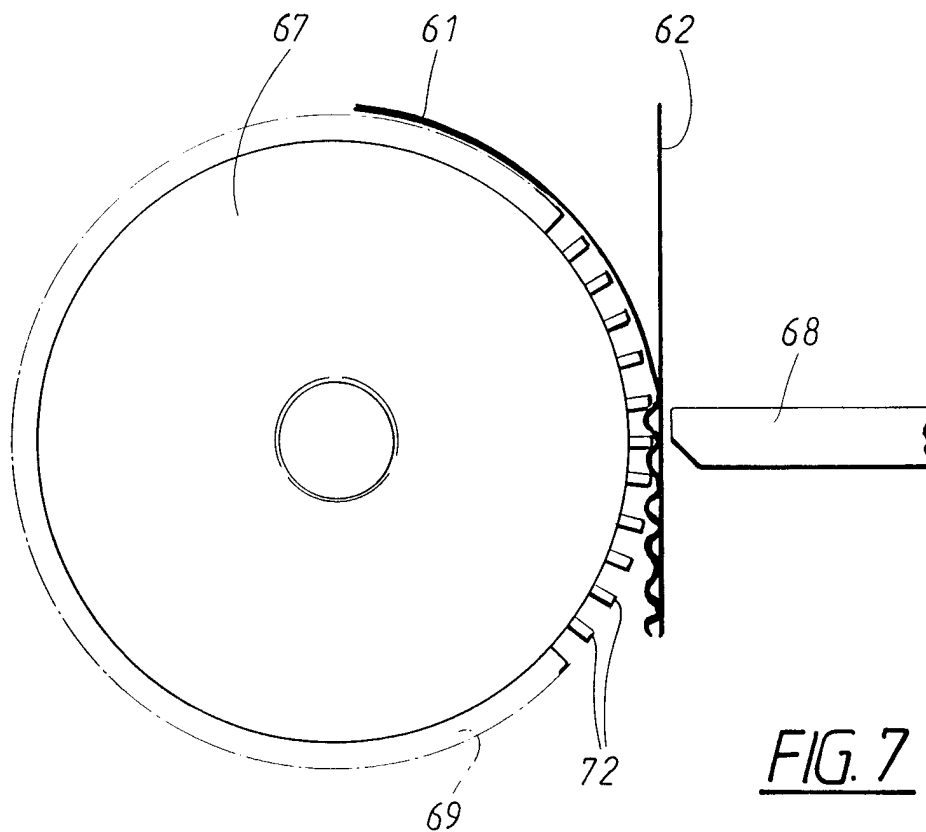

FIG. 7

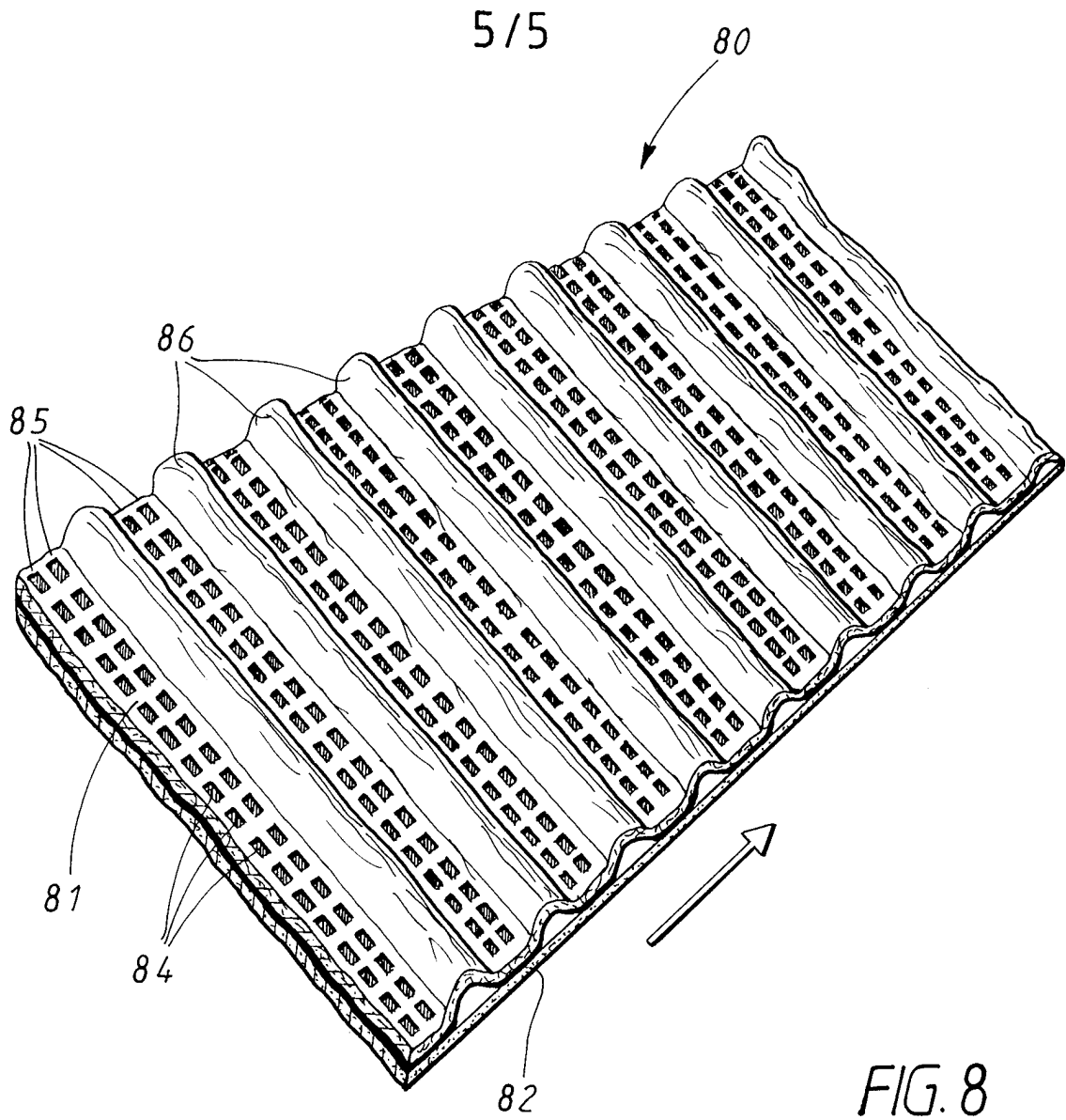

FIG. 8

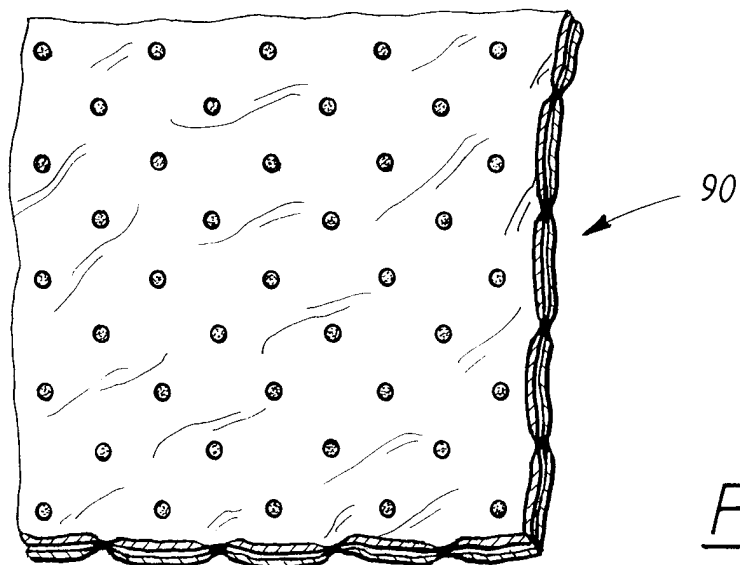

FIG. 9

INTERNATIONAL SEARCH REPORT

International application No.

PCT/SE 97/01954

A. CLASSIFICATION OF SUBJECT MATTER		
IPC6: A61F 13/15 According to International Patent Classification (IPC) or to both national classification and IPC		
B. FIELDS SEARCHED		
Minimum documentation searched (classification system followed by classification symbols)		
IPC6: A61F		
Documentation searched other than minimum documentation to the extent that such documents are included in the fields searched		
SE,DK,FI,NO classes as above		
Electronic data base consulted during the international search (name of data base and, where practicable, search terms used)		
C. DOCUMENTS CONSIDERED TO BE RELEVANT		
Category*	Citation of document, with indication, where appropriate, of the relevant passages	Relevant to claim No.
X	EP 0059014 A2 (THE PROCTER & GAMBLE COMPANY), 1 Sept 1982 (01.09.82), page 3, line 34 - line 37; page 14, line 20 - line 24, figures 5,12, claim 1 --	1-1
X	EP 0601610 A1 (JAPAN ABSORBENT TECHNOLOGY INSTITUTE), 15 June 1994 (15.06.94), column 3, line 45 - column 5, line 8, figures 1,4,5, claim 1 -- -----	1-11
<input type="checkbox"/> Further documents are listed in the continuation of Box C. <input checked="" type="checkbox"/> See patent family annex.		
* Special categories of cited documents: "A" document defining the general state of the art which is not considered to be of particular relevance "E" earlier document but published on or after the international filing date "L" document which may throw doubts on priority claim(s) or which is cited to establish the publication date of another citation or other special reason (as specified) "O" document referring to an oral disclosure, use, exhibition or other means "P" document published prior to the international filing date but later than the priority date claimed "T" later document published after the international filing date or priority date and not in conflict with the application but cited to understand the principle or theory underlying the invention "X" document of particular relevance: the claimed invention cannot be considered novel or cannot be considered to involve an inventive step when the document is taken alone "Y" document of particular relevance: the claimed invention cannot be considered to involve an inventive step when the document is combined with one or more other such documents, such combination being obvious to a person skilled in the art "&" document member of the same patent family		
Date of the actual completion of the international search		Date of mailing of the international search report
9 March 1998		18 -03- 1998
Name and mailing address of the ISA/ Swedish Patent Office Box 5055, S-102 42 STOCKHOLM Facsimile No. +46 8 666 02 86		Authorized officer Ingrid Falk Telephone No. +46 8 782 25 00

INTERNATIONAL SEARCH REPORT

Information on patent family members

03/02/98

International application No.

PCT/SE 97/01954

Patent document cited in search report	Publication date	Patent family member(s)	Publication date
EP 0059014 A2	01/09/82	SE 0059014 T3	
		AU 544422 B	23/05/85
		AU 8072782 A	02/09/82
		BR 8200857 A	28/12/82
		CA 1182602 A	19/02/85
		JP 1587129 C	19/11/90
		JP 2007661 B	20/02/90
		JP 57210003 A	23/12/82
		US 4397645 A	09/08/83

EP 0601610 A1	15/06/94	CA 2103169 A	12/06/94
		JP 6209966 A	02/08/94
