

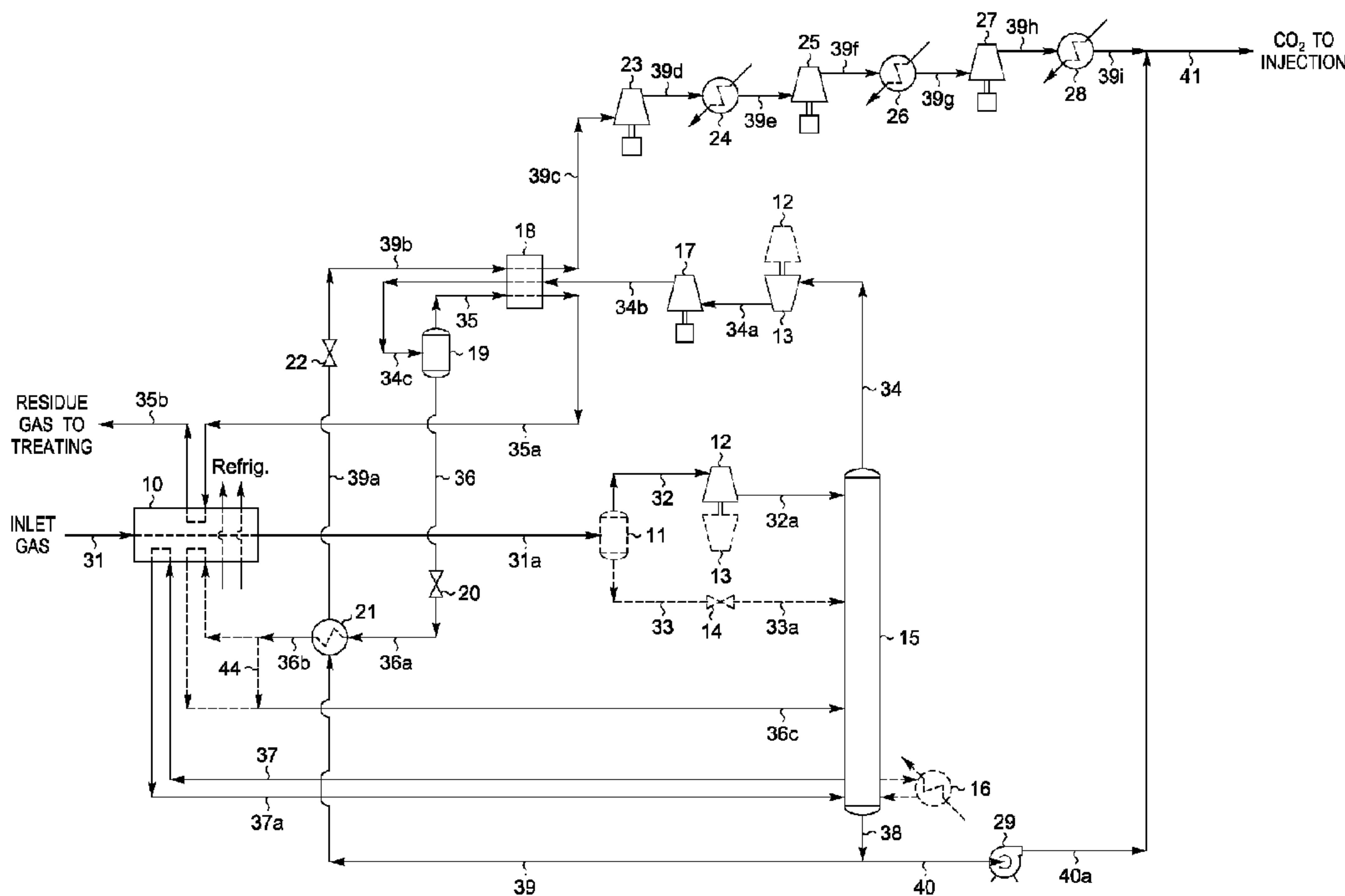

(86) Date de dépôt PCT/PCT Filing Date: 2011/05/27
 (87) Date publication PCT/PCT Publication Date: 2011/12/08
 (45) Date de délivrance/Issue Date: 2016/01/19
 (85) Entrée phase nationale/National Entry: 2012/11/23
 (86) N° demande PCT/PCT Application No.: US 2011/038303
 (87) N° publication PCT/PCT Publication No.: 2011/153087
 (30) Priorités/Priorities: 2010/06/03 (US61/351,059);
 2011/05/27 (US13/117,242)

(51) Cl.Int./Int.Cl. *C07C 7/04* (2006.01),
C01B 3/02 (2006.01), *C01B 3/50* (2006.01),
C01B 31/20 (2006.01), *C07C 9/04* (2006.01)
 (72) Inventeurs/Inventors:
 CUELLAR, KYLE T., US;
 WILKINSON, JOHN D., US;
 HUDSON, HANK M., US
 (73) Propriétaire/Owner:
 ORTLOFF ENGINEERS, LTD., US
 (74) Agent: GOWLING LAFLEUR HENDERSON LLP

(54) Titre : TRAITEMENT D'HYDROCARBURES GAZEUX
 (54) Title: HYDROCARBON GAS PROCESSING



(57) **Abrégé/Abstract:**

A process and an apparatus are disclosed for removing carbon dioxide from a hydrocarbon gas stream. The gas stream is cooled, expanded to intermediate pressure, and supplied to a fractionation tower at a top column feed position. The tower overhead vapor stream is compressed to higher pressure and cooled to partially condense it, forming a condensed stream. The condensed stream is expanded to intermediate pressure, used to subcool a portion of the tower bottom liquid product, then supplied to the tower at a mid-column feed position. The subcooled portion of the tower bottom liquid product is expanded to lower pressure and used to cool the compressed overhead vapor stream. The quantities and temperatures of the feeds to the fractionation tower are effective to maintain the overhead temperature of the fractionation tower at a temperature whereby the major portion of the carbon dioxide is recovered in the tower bottom liquid product.

(12) INTERNATIONAL APPLICATION PUBLISHED UNDER THE PATENT COOPERATION TREATY (PCT)

(19) World Intellectual Property Organization
International Bureau(43) International Publication Date
8 December 2011 (08.12.2011)(10) International Publication Number
WO 2011/153087 A1(51) International Patent Classification:
B01D 19/00 (2006.01)(21) International Application Number:
PCT/US2011/038303(22) International Filing Date:
27 May 2011 (27.05.2011)

(25) Filing Language: English

(26) Publication Language: English

(30) Priority Data:
61/351,059 3 June 2010 (03.06.2010) US
13/117,242 27 May 2011 (27.05.2011) US(71) Applicant (for all designated States except US): **ORT-LOFF ENGINEERS, LTD** [US/US]; 415 West Wall, Suite 2000, Midland, TX 79701 (US).

(72) Inventors; and

(75) Inventors/Applicants (for US only): **CUELLAR, Kyle, T.** [US/US]; 1611 Cottage Point, Katy, TX 77494 (US). **WILKINSON, John, D.** [US/US]; 4113 Tanforan Avenue, Midland, TX 79707 (US). **HUDSON, Hank, M.** [US/US]; 2508 W. Sinclair Avenue, Midland, TX 79705 (US).(74) Agent: **RUSSO, Alicia, A.**; Fitzpatrick, Cella, Harper & Scinto, 1290 Avenue Of The Americas, New York, NY 10104-3800 (US).

(81) Designated States (unless otherwise indicated, for every kind of national protection available): AE, AG, AL, AM, AO, AT, AU, AZ, BA, BB, BG, BH, BR, BW, BY, BZ, CA, CH, CL, CN, CO, CR, CU, CZ, DE, DK, DM, DO, DZ, EC, EE, EG, ES, FI, GB, GD, GE, GH, GM, GT, HN, HR, HU, ID, IL, IN, IS, JP, KE, KG, KM, KN, KP, KR, KZ, LA, LC, LK, LR, LS, LT, LU, LY, MA, MD, ME, MG, MK, MN, MW, MX, MY, MZ, NA, NG, NI, NO, NZ, OM, PE, PG, PH, PL, PT, RO, RS, RU, SC, SD, SE, SG, SK, SL, SM, ST, SV, SY, TH, TJ, TM, TN, TR, TT, TZ, UA, UG, US, UZ, VC, VN, ZA, ZM, ZW.

(84) Designated States (unless otherwise indicated, for every kind of regional protection available): ARIPO (BW, GH, GM, KE, LR, LS, MW, MZ, NA, SD, SL, SZ, TZ, UG, ZM, ZW), Eurasian (AM, AZ, BY, KG, KZ, MD, RU, TJ, TM), European (AL, AT, BE, BG, CH, CY, CZ, DE, DK, EE, ES, FI, FR, GB, GR, HR, HU, IE, IS, IT, LT, LU, LV, MC, MK, MT, NL, NO, PL, PT, RO, RS, SE, SI, SK, SM, TR), OAPI (BF, BJ, CF, CG, CI, CM, GA, GN, GQ, GW, ML, MR, NE, SN, TD, TG).

Published:

— with international search report (Art. 21(3))

(54) Title: HYDROCARBON GAS PROCESSING

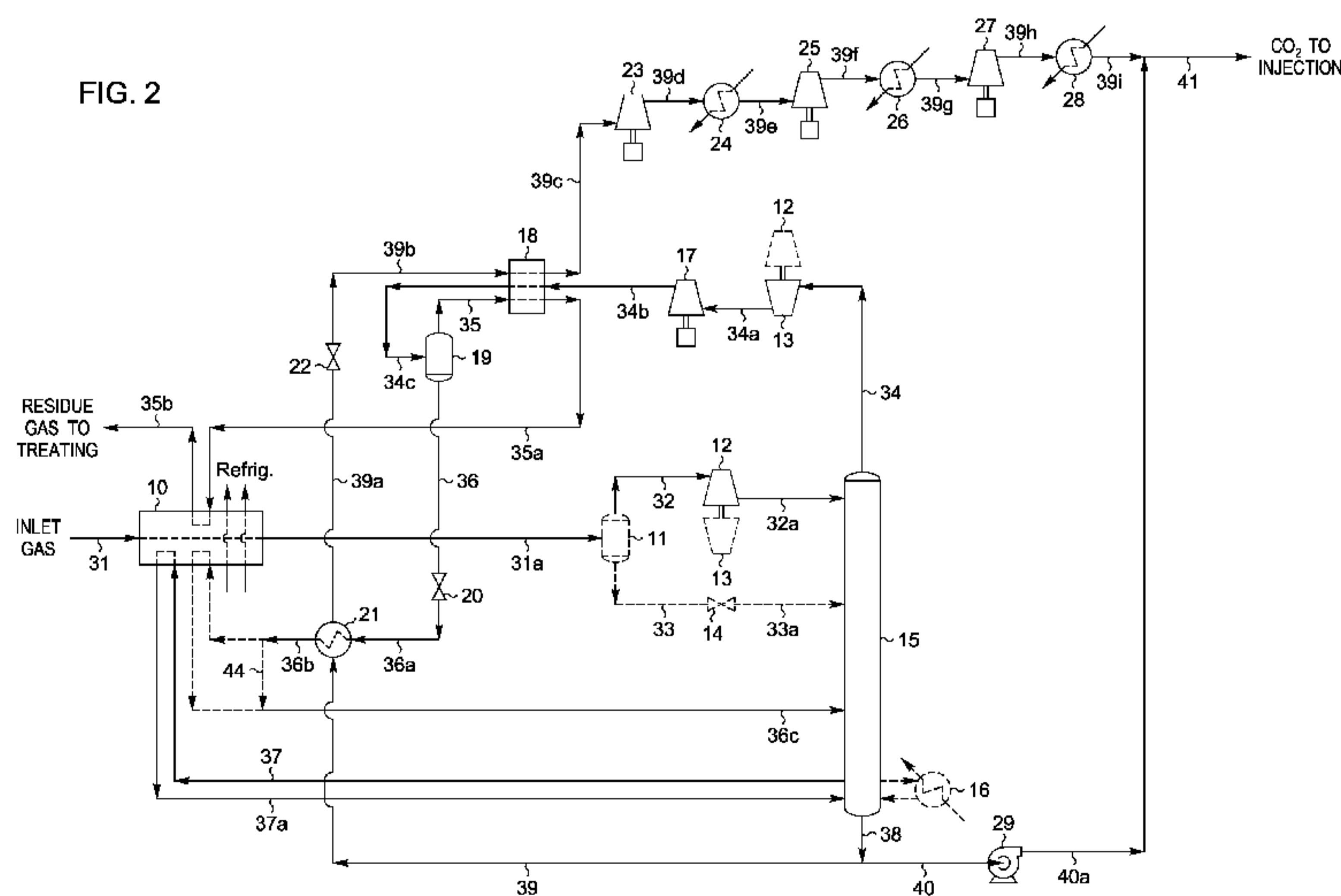

(57) Abstract: A process and an apparatus are disclosed for removing carbon dioxide from a hydrocarbon gas stream. The gas stream is cooled, expanded to intermediate pressure, and supplied to a fractionation tower at a top column feed position. The tower overhead vapor stream is compressed to higher pressure and cooled to partially condense it, forming a condensed stream. The condensed stream is expanded to intermediate pressure, used to subcool a portion of the tower bottom liquid product, then supplied to the tower at a mid-column feed position. The subcooled portion of the tower bottom liquid product is expanded to lower pressure and used to cool the compressed overhead vapor stream. The quantities and temperatures of the feeds to the fractionation tower are effective to maintain the overhead temperature of the fractionation tower at a temperature whereby the major portion of the carbon dioxide is recovered in the tower bottom liquid product.

WO 2011/153087 A1

HYDROCARBON GAS PROCESSING

SPECIFICATION

BACKGROUND OF THE INVENTION

[0001] Hydrocarbons are found in a variety of gases, such as natural gas, refinery gas, and synthetic gas streams obtained from other hydrocarbon materials such as coal, crude oil, naphtha, oil shale, tar sands, and lignite. In many cases, the gas streams from these sources are contaminated with high concentrations of carbon dioxide, making the gas streams unsuitable for use as fuel, chemical plant feedstock, or other purposes. There are a variety of processes that have been developed to remove the carbon dioxide using chemical, physical, and hybrid solvents. Other processes have been developed that use a refrigerated absorbent stream composed of heavy (C₄-C₁₀ typically) hydrocarbons to remove the carbon dioxide in a distillation column, such as the process described in U.S. Patent No. 4,318,723. All of these processes have increasingly higher capital cost and operating cost as the carbon dioxide concentration in the gas stream increases, which often makes processing of such gas streams uneconomical.

[0002] One method for improving the economics of processing gas streams containing high concentrations of carbon dioxide is to provide bulk separation of the carbon dioxide from the gas stream prior to processing with solvents or absorbents, so that only a minor fraction of the carbon dioxide must then be removed from the gas stream. For example, semi-permeable membranes have often been used for bulk removal of carbon dioxide. However, a significant fraction of the lighter hydrocarbons in the gas stream are often "lost" in the carbon dioxide stream that is separated by bulk removal processes of this type.

[0003] A better alternative for bulk removal of carbon dioxide is to use distillation to fractionate the gas stream into a light hydrocarbon stream and a carbon dioxide stream, so that removal of the residual carbon dioxide from the light hydrocarbon stream is all that is required to produce pipeline-quality gas for use as fuel, chemical plant feedstock, etc. The majority of the carbon dioxide that is removed is recovered as a liquid rather than a vapor, allowing the carbon dioxide to be pumped (rather than compressed) for subsequent use in tertiary oil recovery operations or for other purposes, resulting in substantial reductions in capital cost and operating cost.

[0004] The present invention is generally concerned with the removal of the majority of the carbon dioxide from such gas streams. A typical analysis of a gas stream to be processed in accordance with this invention would be, in approximate mole percent, 44.3% hydrogen, 13.0% carbon monoxide, 4.0% methane, and 38.5% carbon dioxide, with the balance made up of nitrogen and argon. Sulfur containing gases are also sometimes present.

[0005] In a typical distillation process for removing carbon dioxide, a feed gas stream under pressure is cooled by heat exchange with other streams of the process and/or external sources of refrigeration such as a propane compression-refrigeration system. The gas is condensed as it is cooled, and the high-pressure liquid is expanded to an intermediate

pressure, resulting in further cooling of the stream due to the vaporization occurring during expansion of the liquids. The expanded stream, comprising a mixture of liquid and vapor, is fractionated in a distillation column to separate residual methane, nitrogen, and other volatile gases as overhead vapor from the carbon dioxide and the heavier hydrocarbon components as bottom liquid product. A portion of the liquid carbon dioxide can be flash expanded to lower pressure and thereafter used to provide low-level refrigeration to the process streams if desired.

[0006] The present invention employs a novel means of condensing the distillation column overhead vapor to increase the carbon dioxide removal efficiency. Instead of cooling the column overhead vapor to condense reflux for the fractionation column, the overhead vapor is compressed to higher pressure and then cooled to partially condense it. The resulting condensate is mostly liquid carbon dioxide, which can be flash expanded to intermediate pressure and used to provide mid-level refrigeration to the process streams before being returned to the distillation column at a mid-column feed point. In addition, the residue gas that remains after the condensate has been removed is suitable to be sent to treating without requiring further compression. Surprisingly, applicants have found that this novel process arrangement not only allows removing more of the carbon dioxide, but also reduces the power consumption required to achieve a given level of carbon dioxide removal, thereby increasing the process efficiency and reducing the operating cost of the facility.

[0007] In accordance with the present invention, it has been found that more than 75% of the carbon dioxide can be removed while leaving more than 99.8% of the methane and lighter components in the residue gas stream. The present invention, although applicable at lower pressures and warmer temperatures, is particularly advantageous when processing feed gases in the range of 400 to 1500 psia [2,758 to 10,342 kPa(a)] or higher under conditions requiring distillation column overhead temperatures of -50°F [-46°C] or colder.

[0008] For a better understanding of the present invention, reference is made to the following examples and drawings. Referring to the drawings:

[0009] FIG. 1 is a flow diagram of a prior art synthesis gas processing plant; and

[0010] FIG. 2 is a flow diagram of a synthesis gas processing plant in accordance with the present invention.

[0011] In the following explanation of the above figures, tables are provided summarizing flow rates calculated for representative process conditions. In the tables appearing herein, the values for flow rates (in moles per hour) have been rounded to the nearest whole number for convenience. The total stream rates shown in the tables include all non-hydrocarbon components and hence are generally larger than the sum of the stream flow rates for the hydrocarbon components. Temperatures indicated are approximate values rounded to the nearest degree. It should also be noted that the process design calculations performed for the purpose of comparing the processes depicted in the figures are based on the assumption of no heat leak from (or to) the surroundings to (or from) the process. The quality of commercially available insulating materials makes this a very reasonable assumption and one that is typically made by those skilled in the art.

[0012] For convenience, process parameters are reported in both the traditional British units and in the units of the Système International d'Unités (SI). The molar flow rates given in the tables may be interpreted as either pound moles per hour or kilogram moles per hour. The energy consumptions reported as horsepower (HP) and/or thousand British Thermal Units per hour (MBTU/Hr) correspond to the stated molar flow rates in pound moles per hour. The energy consumptions reported as kilowatts (kW) correspond to the stated molar flow rates in kilogram moles per hour.

DESCRIPTION OF THE PRIOR ART

[0013] FIG. 1 is a process flow diagram showing the design of a processing plant to remove carbon dioxide from synthesis gas using a prior art process. In this simulation of the process, inlet gas enters the plant at 120°F [49°C] and 1080 psia [7,446 kPa(a)] as stream **31**. The feed stream is usually dehydrated to prevent hydrate (ice) formation under cryogenic conditions. Solid and liquid desiccants have both been used for this purpose.

[0014] The feed stream **31** is cooled to -20°F [-29°C] in heat exchanger **10** by heat exchange with column reboiler liquids at 49°F [9°C] (stream **37**), column side reboiler liquids at 34°F [1°C] (stream **42**), and propane refrigerant. Stream **31a** is further cooled in heat exchanger **50** by heat exchange with cool carbon dioxide vapor at -56°F [-49°C] (stream **43**), cold residue gas at -60°F [-51°C] (stream **35**), and pumped liquid at -60°F [-51°C] (stream **36a**). The further cooled stream **31b** enters separator **11** at -27°F [-33°C] and 1049 psia [7,233 kPa(a)] where the vapor (stream **32**) is separated from the condensed liquid (stream **33**).

[0015] The vapor from separator **11** (stream **32**) enters a work expansion machine **12** in which mechanical energy is extracted from this portion of the high pressure feed. The machine **12** expands the vapor substantially isentropically to the operating pressure (approximately 665 psia [4,583 kPa(a)]) of fractionation tower **15**, with the work expansion cooling the expanded stream **32a** to a temperature of approximately -48°F [-45°C]. The typical commercially available expanders are capable of recovering on the order of 80-88% of the work theoretically available in an ideal isentropic expansion. The work recovered is often used to drive a centrifugal compressor (such as item **13**) that can be used to re-compress the residue gas (stream **35b**), for example. The partially condensed expanded stream **32a** is thereafter supplied to fractionation tower **15** at its top column feed point. The separator liquid (stream **33**) is expanded to the operating pressure of fractionation tower **15** by

expansion valve **14**, cooling stream **33a** to -28°F [-33°C] before it is supplied to fractionation tower **15** at an upper mid-column feed point.

[0016] Overhead vapor stream **34** leaves fractionation tower **15** at -48°F [-45°C] and is cooled and partially condensed in heat exchanger **18**. The partially condensed stream **34a** enters separator **19** at -60°F [-51°C] and 658 psia [4,535 kPa(a)] where the vapor (cold residue gas stream **35**) is separated from the condensed liquid (stream **36**). Liquid stream **36** is pumped to slightly above the operating pressure of fractionation tower **15** by pump **51** before stream **36a** enters heat exchanger **50** and is heated to -26°F [-32°C] by heat exchange with the feed gas as described previously. The heated stream **36b** is thereafter supplied as feed to fractionation tower **15** at a lower mid-column feed point.

[0017] Fractionation tower **15** is a conventional distillation column containing a plurality of vertically spaced trays, one or more packed beds, or some combination of trays and packing. It also includes reboilers (such as the reboiler and the side reboiler described previously) which heat and vaporize a portion of the liquids flowing down the column to provide the stripping vapors which flow up the column to strip the column bottom liquid product (stream **38**) of methane and lighter components. The trays and/or packing provide the necessary contact between the stripping vapors rising upward and cold liquid falling downward, so that the bottom product stream **38** exits the bottom of the tower at 50°F [10°C], based on reducing the methane concentration in the bottom product to 0.47% on a molar basis.

[0018] Column bottom product stream **38** is predominantly liquid carbon dioxide. A small portion (stream **39**) is subcooled in heat exchanger **21** by cool residue gas stream **35a**. The subcooled liquid (stream **39a**) at -20°F [-29°C] is expanded to lower pressure by expansion valve **22** and partially vaporized, further cooling stream **39b** to -65°F [-54°C] before it enters heat exchanger **18**. The residual liquid in stream **39b** functions as refrigerant

in heat exchanger **18** to provide cooling of stream **34** as described previously, with the resulting carbon dioxide vapor leaving at -56°F [-49°C] as stream **43**. Since stream **39b** could contain small amounts of heavier hydrocarbons, a small liquid purge (stream **44**) may be drawn off from heat exchanger **18** to prevent an accumulation of heavier hydrocarbons in the refrigerant liquid that could elevate its boiling point and reduce the cooling efficiency of heat exchanger **18**.

[0019] The cool carbon dioxide vapor from heat exchanger **18** (stream **43**) is heated to -28°F [-33°C] in heat exchanger **50** by heat exchange with the feed gas as described previously. The warm carbon dioxide vapor (stream **43a**) at 74 psia [508 kPa(a)] is then compressed to high pressure in three stages by compressors **23**, **25**, and **27**, with cooling to 120°F [49°C] after each stage of compression by discharge coolers **24**, **26**, and **28**. The remaining portion (stream **40**) of column bottom product stream **38** is pumped to high pressure by pump **29** so that stream **40a** can combine with the high pressure gas (stream **43g**) leaving discharge cooler **28**, forming high pressure carbon dioxide stream **41** which then flows to reinjection at 82°F [28°C] and 1115 psia [7,688 kPa(a)].

[0020] The cool residue gas (stream **35a**) leaves heat exchanger **50** at -28°F [-33°C] after heat exchange with the feed gas as described previously, and is further heated to -8°F [-22°C] in heat exchanger **21** by heat exchange with liquid carbon dioxide stream **39** as described previously. The warm residue gas stream **35b** is then re-compressed in two stages, compressor **13** driven by expansion machine **12** and compressor **17** driven by a supplemental power source. Residue gas stream **35d** then flows to treating at 90°F [32°C] and 1115 psia [7,688 kPa(a)].

[0021] A summary of stream flow rates and energy consumption for the process illustrated in FIG. 1 is set forth in the following table:

Table I

(FIG. 1)

Stream Flow Summary - Lb. Moles/Hr [kg moles/Hr]

<u>Stream</u>	<u>Hydrogen</u>	<u>C. Monoxide</u>	<u>Methane</u>	<u>C. Dioxide</u>	<u>Total</u>
31	22,177	6,499	2,014	19,288	50,115
32	21,992	6,311	1,901	10,700	41,036
33	185	188	113	8,588	9,079
34	22,201	6,535	1,981	9,654	40,509
36	24	36	24	2,536	2,622
38	0	0	57	12,170	12,228
39	0	0	15	3,235	3,250
43	0	0	15	3,235	3,250
44	0	0	0	0	0
40	0	0	42	8,935	8,978
35	22,177	6,499	1,957	7,118	37,887
41	0	0	57	12,170	12,228

Recovery / Removal*

Methane and Lighter	99.34%	(recovered in the Residue Gas)
Carbon Dioxide	63.10%	(removed from the Residue Gas)

Carbon Dioxide Concentrations*

Residue Gas	18.79%
Carbon Dioxide Product	99.50%

Power

Carbon Dioxide Compression	4,955 HP	[8,146 kW]
Residue Gas Compression	5,717 HP	[9,398 kW]
Refrigerant Compression	14,960 HP	[24,594 kW]
Carbon Dioxide Pump	324 HP	[533 kW]
Totals	25,956 HP	[42,671 kW]

* (Based on un-rounded flow rates)

DESCRIPTION OF THE INVENTION

[0022] FIG. 2 illustrates a flow diagram of a process in accordance with the present invention. The feed gas composition and conditions considered in the process presented in FIG. 2 are the same as those in FIG. 1. Accordingly, the FIG. 2 process can be compared with that of the FIG. 1 process to illustrate the advantages of the present invention.

[0023] In the simulation of the FIG. 2 process, inlet gas enters the plant at 120°F [49°C] and 1080 psia [7,446 kPa(a)] as stream **31** and is cooled in heat exchanger **10** by heat exchange with column reboiler liquids at 47°F [8°C] (stream **37**), residue gas at 30°F [-1°C] (stream **35a**), cool expanded liquids at 20°F [-7°C] (stream **36b**), and propane refrigerant.

The cooled stream **31a** enters separator **11** at -30°F [-34°C] and 1049 psia [7,233 kPa(a)] where the vapor (stream **32**) is separated from the condensed liquid (stream **33**).

[0024] The vapor from separator **11** (stream **32**) enters a work expansion machine **12** in which mechanical energy is extracted from this portion of the high pressure feed. The machine **12** expands the vapor substantially isentropically to the operating pressure (approximately 640 psia [4,413 kPa(a)]) of fractionation tower **15**, with the work expansion cooling the expanded stream **32a** to a temperature of approximately -54°F [-48°C]. The partially condensed expanded stream **32a** is thereafter supplied to fractionation tower **15** at its top column feed point. The separator liquid (stream **33**) is expanded to the operating pressure of fractionation tower **15** by expansion valve **14**, cooling stream **33a** to -30°F [-35°C] before it is supplied to fractionation tower **15** at an upper mid-column feed point.

[0025] Overhead vapor stream **34** leaves fractionation tower **15** at -52°F [-47°C] and is compressed in two stages, compressor **13** driven by expansion machine **12** and compressor **17** driven by a supplemental power source. The compressed stream **34b** is then cooled and partially condensed in heat exchanger **18**. The partially condensed stream **34c** enters separator **19** at -60°F [-51°C] and 1130 psia [7,791 kPa(a)] where the vapor (cold residue gas stream **35**) is separated from the condensed liquid (stream **36**). Liquid stream **36** is expanded to slightly above the operating pressure of fractionation tower **15** by expansion valve **20** before stream **36a** enters heat exchanger **21**. The expanded stream **36a** is heated from -59°F [-51°C] to 20°F [-7°C] and partially vaporized by heat exchange with liquid carbon dioxide stream **39** (which is described further below in paragraph [0027]). The partially vaporized stream **36b** is further vaporized in heat exchanger **10** by heat exchange with the feed gas as described previously, and stream **36c** at 38°F [3°C] is thereafter supplied as feed to fractionation tower **15** at a lower mid-column feed point.

[0026] Fractionation tower **15** is a conventional distillation column containing a plurality of vertically spaced trays, one or more packed beds, or some combination of trays and packing. It also includes reboilers (such as the reboiler described previously, and optionally a reboiler **16** heated by an external source of heat) which heat and vaporize a portion of the liquids flowing down the column to provide the stripping vapors which flow up the column to strip the column bottom liquid product (stream **38**) of methane and lighter components. The trays and/or packing provide the necessary contact between the stripping vapors rising upward and cold liquid falling downward, so that the bottom product stream **38** exits the bottom of the tower at 48°F [9°C], based on reducing the methane concentration in the bottom product to 0.30% on a molar basis.

[0027] Column bottom product stream **38** is predominantly liquid carbon dioxide. A minor portion (stream **39**) is subcooled in heat exchanger **21** by flash expanded liquid stream **36a** as described previously. The subcooled liquid (stream **39a**) at -33°F [-36°C] is expanded to lower pressure by expansion valve **22** and partially vaporized, further cooling stream **39b** to -65°F [-54°C] before it enters heat exchanger **18**. The residual liquid in stream **39b** functions as refrigerant in heat exchanger **18** to provide a portion of the cooling of compressed overhead vapor stream **34b** as described previously, with the resulting carbon dioxide vapor leaving at 22°F [-6°C] (stream **39c**).

[0028] The warm carbon dioxide vapor (stream **39c**) at 78 psia [536 kPa(a)] is then compressed to high pressure in three stages by compressors **23**, **25**, and **27**, with cooling to 120°F [49°C] after each stage of compression by discharge coolers **24**, **26**, and **28**. The remaining portion (stream **40**) of column bottom product stream **38** is pumped to high pressure by pump **29** so that stream **40a** can combine with the high pressure gas (stream **39i**) leaving discharge cooler **28**, forming high pressure carbon dioxide stream **41** which then flows to reinjection at 84°F [29°C] and 1115 psia [7,688 kPa(a)].

[0029] The cold residue gas (stream **35**) from separator **19** enters heat exchanger **18** and is heated to 30°F [-1°C] by heat exchange with compressed overhead vapor stream **34b** as described previously. Cool residue gas stream **35a** is further heated to 72°F [22°C] in heat exchanger **10** by heat exchange with the feed gas as described previously. The warm residue gas stream **35b** then flows to treating at 1115 psia [7,688 kPa(a)].

[0030] A summary of stream flow rates and energy consumption for the process illustrated in FIG. 2 is set forth in the following table:

Table II

(FIG. 2)

Stream Flow Summary - Lb. Moles/Hr [kg moles/Hr]

<u>Stream</u>	<u>Hydrogen</u>	<u>C. Monoxide</u>	<u>Methane</u>	<u>C. Dioxide</u>	<u>Total</u>
31	22,177	6,499	2,014	19,288	50,115
32	21,984	6,297	1,892	10,038	40,343
33	193	202	122	9,250	9,772
34	22,256	6,607	2,041	9,052	40,092
36	79	109	71	4,257	4,517
38	0	1	44	14,493	14,540
39	0	0	14	4,493	4,507
40	0	1	30	10,000	10,033
35	22,177	6,498	1,970	4,795	35,575
41	0	1	44	14,493	14,540

Recovery / Removal*

Methane and Lighter	99.85%	(recovered in the Residue Gas)
Carbon Dioxide	75.15%	(removed from the Residue Gas)

Carbon Dioxide Concentrations*

Residue Gas	13.47%
Carbon Dioxide Product	99.69%

Power

Carbon Dioxide Compression	6,742 HP	[11,084 kW]
Overhead Vapor Compression	5,095 HP	[8,376 kW]
Refrigerant Compression	16,184 HP	[26,606 kW]
Carbon Dioxide Pump	378 HP	[621 kW]
Totals	28,399 HP	[46,687 kW]

* (Based on un-rounded flow rates)

[0031] A comparison of Tables I and II shows that, compared to the prior art, the present invention provides better methane recovery (99.85%, versus 99.44% for the prior art), much better carbon dioxide removal (75.15%, versus 63.10% for the prior art), much lower carbon dioxide concentration in the residue gas (13.47%, versus 18.79% for the prior art), and better carbon dioxide purity (99.69%, versus 99.50% for the prior art). In addition, further comparison of Tables I and II shows that this superior process performance was achieved using less power per unit of carbon dioxide removed than the prior art. In terms of the specific power consumption, the present invention represents an 8% improvement over the prior art of the FIG. 1 process, reducing the specific power consumption from 2.13 HP-H/Lb. mole [3.51 kW-H/kg mole] of carbon dioxide removed for the prior art to 1.96 HP-H/Lb. mole [3.22 kW-H/kg mole] for the present invention.

[0032] The improvement in energy efficiency provided by the present invention over that of the prior art of the FIG. 1 process is primarily due to two factors. First, compressing overhead vapor stream **34** from fractionation tower **15** to higher pressure before supplying it to heat exchanger **18** makes it much easier to condense carbon dioxide from the stream. As can be seen by comparing stream **36** in Tables I and II, the carbon dioxide condensed in stream **36** increases from 2,536 Lb. Moles/Hr [2,536 kg moles/Hr] for the prior art to 4,257 Lb. Moles/Hr [4,257 kg moles/Hr] for the present invention. The result is that the residue gas that remains (stream **35**) contains much less carbon dioxide, 4,795 Lb. Moles/Hr [4,795 kg moles/Hr] for the present invention versus 7,118 Lb. Moles/Hr [7,118 kg moles/Hr] for the prior art.

[0033] Second, the greater quantity of liquid condensed in stream **36** for the present invention provides a process stream that can be used more effectively for mid-level refrigeration within the process. The resulting flashed stream **36a** has 72% more flow than pumped stream **36a** in the prior art process, allowing it to subcool a larger quantity of liquid carbon dioxide in stream **39** (39% more than the prior art) to a lower temperature (-33°F [-36°C], versus -20°F [-29°C] for the prior art), so that the resulting flashed carbon dioxide stream **39b** for the present invention contains a much larger quantity of liquid that can be used as refrigerant to condense carbon dioxide from overhead vapor stream **34** in heat exchanger **18**.

[0034] The net result of these two factors is to capture significantly more of the carbon dioxide in column bottom product stream **38** (19% more compared to the FIG. 1 prior art process) at greater efficiency using less specific power. This also means that much less of the carbon dioxide remains in residue gas stream **35**, greatly reducing (or perhaps eliminating entirely) the downstream treating needed to condition the residue gas for subsequent processing or use, further reducing the total treating cost for a given application.

Other Embodiments

[0035] As described earlier for the embodiment of the present invention shown in FIG. 2, feed stream **31** is partially condensed as it is cooled in heat exchanger **10**, and the resulting vapor stream **32** and liquid stream **33** are then expanded to the operating pressure of fractionation column **15**. However, the present invention is not limited to this embodiment. Depending on the quantity of heavier hydrocarbons in the feed gas and the feed gas pressure, the cooled feed stream **31a** may not contain any liquid (because it is above its dewpoint, or because it is above its cricondenbar). In such cases, separator **11** is not required. Some circumstances may favor total condensation of the feed gas, followed by expanding the liquid or dense phase fluid to the operating pressure of fractionation column **15**. Such cases may likewise not require separator **11**.

[0036] Feed gas conditions, plant size, available equipment, or other factors may indicate that elimination of work expansion machine **12**, or replacement with an alternate expansion device (such as an expansion valve), is feasible. Although individual stream expansion is depicted in particular expansion devices, alternative expansion means may be employed where appropriate. For example, conditions may warrant work expansion of liquid streams **33**, **36**, and/or **39a**.

[0037] In accordance with the present invention, the use of external refrigeration to supplement the cooling available to the inlet gas and/or compressed overhead vapor stream **34b** from other process streams may be employed, particularly in the case of a rich inlet gas. The use and distribution of separator liquids and/or demethanizer side draw liquids for process heat exchange, and the particular arrangement of heat exchangers for inlet gas cooling must be evaluated for each particular application, as well as the choice of process streams for specific heat exchange services. For instance, some circumstances may favor supplying partially vaporized stream **36b** directly to fractionation tower **15** (via stream **44** in

FIG. 2) rather than further vaporizing it in heat exchanger 10 and then supplying the resulting stream 36c to fractionation tower 15.

[0038] Depending on the temperature and richness of the feed gas and the amount of methane allowed in liquid product stream 38, there may not be sufficient heating available from feed stream 31 to cause the liquid leaving fractionation column 15 to meet the product specifications. In such cases, the fractionation column 15 may include one or more reboilers (such as reboiler 16) heated by an external source of heat.

[0039] In some circumstances, the portion (stream 39) of column bottom product stream 38 that is used to provide refrigeration may not need to be restored to high pressure after it has been heated (stream 39c). In such cases, the compression and cooling shown (compressors 23, 25, and 27 and discharge coolers 24, 26, and 28) may not be needed, and only stream 40a flows to stream 41.

[0040] The present invention provides improved separation of carbon dioxide from hydrocarbon gas streams per amount of utility consumption required to operate the process. An improvement in utility consumption required for operating the process may appear in the form of reduced power requirements for compression or re-compression, reduced power requirements for pumping, reduced power requirements for external refrigeration, reduced energy requirements for tower reboiling, or a combination thereof.

[0041] While there have been described what are believed to be preferred embodiments of the invention, those skilled in the art will recognize that other and further modifications may be made thereto, e.g. to adapt the invention to various conditions, types of feed, or other requirements.

We claim:

1. A process for the separation of a gas stream containing at least methane and carbon dioxide into a volatile residue gas fraction containing a major portion of said methane and a relatively less volatile fraction containing a major portion of said carbon dioxide wherein

(1) said gas stream is cooled, thereby forming a cooled stream;

(2) said cooled stream is expanded to intermediate pressure whereby it is further cooled;

(3) said expanded cooled stream is supplied as a top feed to a distillation column and fractionated at said intermediate pressure into an overhead vapor stream and said relatively less volatile fraction;

(4) said overhead vapor stream is compressed to higher pressure;

(5) said compressed overhead vapor stream is cooled sufficiently to condense at least a part of it, thereby forming a residual vapor stream and a condensed stream;

(6) said condensed stream is expanded to said intermediate pressure and heated, and thereafter supplied to said distillation column at a mid-column feed position;

(7) said relatively less volatile fraction is divided into at least first and second streams;

(8) said second stream is cooled, thereby to supply at least a portion of the heating of step (6);

(9) said cooled second stream is expanded to lower pressure whereby it is further cooled;

(10) said expanded cooled second stream is heated, thereby to supply at least a portion of the cooling of step (5);

(11) said residual vapor stream is heated, thereby to supply at least a portion of the cooling of steps (1) and (5), and thereafter discharging said heated residual vapor stream as said volatile residue gas fraction; and

(12) the quantities and temperatures of said feed streams to said distillation column are effective to maintain the overhead temperature of said distillation column at a temperature whereby the major portion of said carbon dioxide is recovered in said relatively less volatile fraction.

2. A process for the separation of a gas stream containing at least methane and carbon dioxide into a volatile residue gas fraction containing a major portion of said methane and a

relatively less volatile fraction containing a major portion of said carbon dioxide wherein

- (1) said gas stream is cooled sufficiently to partially condense it;
- (2) said partially condensed gas stream is separated, thereby to provide a vapor stream and at least one liquid stream;
- (3) said vapor stream is expanded to intermediate pressure; (4) said expanded vapor stream is supplied as a top feed to a distillation column and fractionated at said intermediate pressure into an overhead vapor stream and said relatively less volatile fraction;
- (5) said at least one liquid stream is expanded to said intermediate pressure, and thereafter supplied to said distillation column at an upper mid-column feed position;
- (6) said overhead vapor stream is compressed to higher pressure;
- (7) said compressed overhead vapor stream is cooled sufficiently to condense at least a part of it, thereby forming a residual vapor stream and a condensed stream;
- (8) said condensed stream is expanded to said intermediate pressure and heated, and thereafter supplied to said distillation column at a lower mid-column feed position below said upper mid-column feed position;
- (9) said relatively less volatile fraction is divided into at least first and second streams;
- (10) said second stream is cooled, thereby to supply at least a portion of the heating of step (8);
- (11) said cooled second stream is expanded to lower pressure whereby it is further cooled;
- (12) said expanded cooled second stream is heated, thereby to supply at least a portion of the cooling of step (7);
- (13) said residual vapor stream is heated, thereby to supply at least a portion of the cooling of steps (1) and (7), and thereafter discharging said heated residual vapor stream as said volatile residue gas fraction; and
- (14) the quantities and temperatures of said feed streams to said distillation column are effective to maintain the overhead temperature of said distillation column at a temperature whereby the major portion of said carbon dioxide is recovered in said relatively less volatile fraction.

3. An apparatus for the separation of a gas stream containing at least methane and carbon

dioxide into a volatile residue gas fraction containing a major portion of said methane and a relatively less volatile fraction containing a major portion of said carbon dioxide comprising

- (1) first heat exchange means to cool said gas stream, thereby forming a cooled stream;
- (2) first expansion means connected to said first heat exchange means to receive said cooled stream and expand it to intermediate pressure;
- (3) distillation column connected to said first expansion means to receive said expanded cooled stream as a top feed thereto, said distillation column being adapted to fractionate said expanded cooled stream at said intermediate pressure into an overhead vapor stream and said relatively less volatile fraction;
- (4) compressing means connected to said distillation column to receive said overhead vapor stream and compress it to higher pressure;
- (5) second heat exchange means connected to said compressing means to receive said compressed overhead vapor stream and cool it sufficiently to condense at least a part of it;
- (6) separating means connected to said second heat exchange means to receive said partially condensed compressed overhead vapor stream and separate it, thereby forming a residual vapor stream and a condensed stream;
- (7) second expansion means connected to said separating means to receive said condensed stream and expand it to said intermediate pressure;
- (8) third heat exchange means connected to said second expansion means to receive said expanded condensed stream and heat it, said third heat exchange means being further connected to said distillation column to supply said heated expanded condensed stream to said distillation column at a mid-column feed position;
- (9) dividing means connected to said distillation column to receive said relatively less volatile fraction and divide it into at least first and second streams; (10) said third heat exchange means being further connected to said dividing means to receive said second stream and cool it, thereby to supply at least a portion of the heating of element (8); (11) third expansion means connected to said third heat exchange means to receive said cooled second stream and expand it to lower pressure;
- (12) said second heat exchange means being further connected to said third expansion means to receive said expanded cooled second stream and heat it, thereby to supply at least a portion of the cooling of element (5);

(13) said second heat exchange means being further connected to said separating means to receive said residual vapor stream and heat it, thereby to supply at least a portion of the cooling of element (5);

(14) said first heat exchange means being further connected to said second heat exchange means to receive said heated residual vapor stream and further heat it, thereby to supply at least a portion of the cooling of element (1), and thereafter discharging said further heated residual vapor stream as said volatile residue gas fraction; and

(15) control means adapted to regulate the quantities and temperatures of said feed streams to said distillation column to maintain the overhead temperature of said distillation column at a temperature whereby the major portion of said carbon dioxide is recovered in said relatively less volatile fraction.

4. An apparatus for the separation of a gas stream containing at least methane and carbon dioxide into a volatile residue gas fraction containing a major portion of said methane and a relatively less volatile fraction containing a major portion of said carbon dioxide comprising

(1) first heat exchange means to cool said gas stream sufficiently to partially condense it, thereby forming a partially condensed gas stream;

(2) first separating means connected to said first heat exchange means to receive said partially condensed gas stream and separate it into a vapor stream and at least one liquid stream;

(3) first expansion means connected to said first separating means to receive said vapor stream and expand it to intermediate pressure;

(4) distillation column connected to said first expansion means to receive said expanded vapor stream as a top feed thereto, said distillation column being adapted to fractionate said expanded vapor stream at said intermediate pressure into an overhead vapor stream and said relatively less volatile fraction;

(5) second expansion means connected to said first separating means to receive said at least one liquid stream and expand it to said intermediate pressure, said second expansion means being further connected to said distillation column to supply said expanded at least one liquid stream to said distillation column at an upper mid-column feed position;

(6) compressing means connected to said distillation column to receive said overhead vapor stream and compress it to higher pressure;

(7) second heat exchange means connected to said compressing means to receive said compressed overhead vapor stream and cool it sufficiently to condense at least a part of it;

(8) second separating means connected to said second heat exchange means to receive said partially condensed compressed overhead vapor stream and separate it, thereby forming a residual vapor stream and a condensed stream;

(9) third expansion means connected to said second separating means to receive said condensed stream and expand it to said intermediate pressure;

(10) third heat exchange means connected to said third expansion means to receive said expanded condensed stream and heat it, said third heat exchange means being further connected to said distillation column to supply said heated expanded condensed stream to said distillation column at a lower mid-column feed position below said upper mid-column feed position;

(11) dividing means connected to said distillation column to receive said relatively less volatile fraction and divide it into at least first and second streams;

(12) said third heat exchange means being further connected to said dividing means to receive said second stream and cool it, thereby to supply at least a portion of the heating of element (10);

(13) fourth expansion means connected to said third heat exchange means to receive said cooled second stream and expand it to lower pressure;

(14) said second heat exchange means being further connected to said fourth expansion means to receive said expanded cooled second stream and heat it, thereby to supply at least a portion of the cooling of element (7);

(15) said second heat exchange means being further connected to said second separating means to receive said residual vapor stream and heat it, thereby to supply at least a portion of the cooling of element (7);

(16) said first heat exchange means being further connected to said second heat exchange means to receive said heated residual vapor stream and further heat it, thereby to supply at least a portion of the cooling of element (1), and thereafter discharging said further heated residual vapor stream as said volatile residue gas fraction; and

(17) control means adapted to regulate the quantities and temperatures of said feed streams to said distillation column to maintain the overhead temperature of said distillation column at a temperature whereby the major portion of said carbon dioxide is recovered in said

relatively less volatile fraction.

5. The apparatus according to claim 3 wherein said first heat exchange means is further connected to said third heat exchange means to receive said heated expanded condensed stream and further heat it, thereby to supply at least a portion of the cooling of element (1), said first heat exchange means being further connected to said distillation column to supply said further heated expanded condensed stream to said distillation column at said mid-column feed position.

6. The apparatus according to claim 4 wherein said first heat exchange means is further connected to said third heat exchange means to receive said heated expanded condensed stream and further heat it, thereby to supply at least a portion of the cooling of element (1), said first heat exchange means being further connected to said distillation column to supply said further heated expanded condensed stream to said distillation column at said lower mid-column feed position.

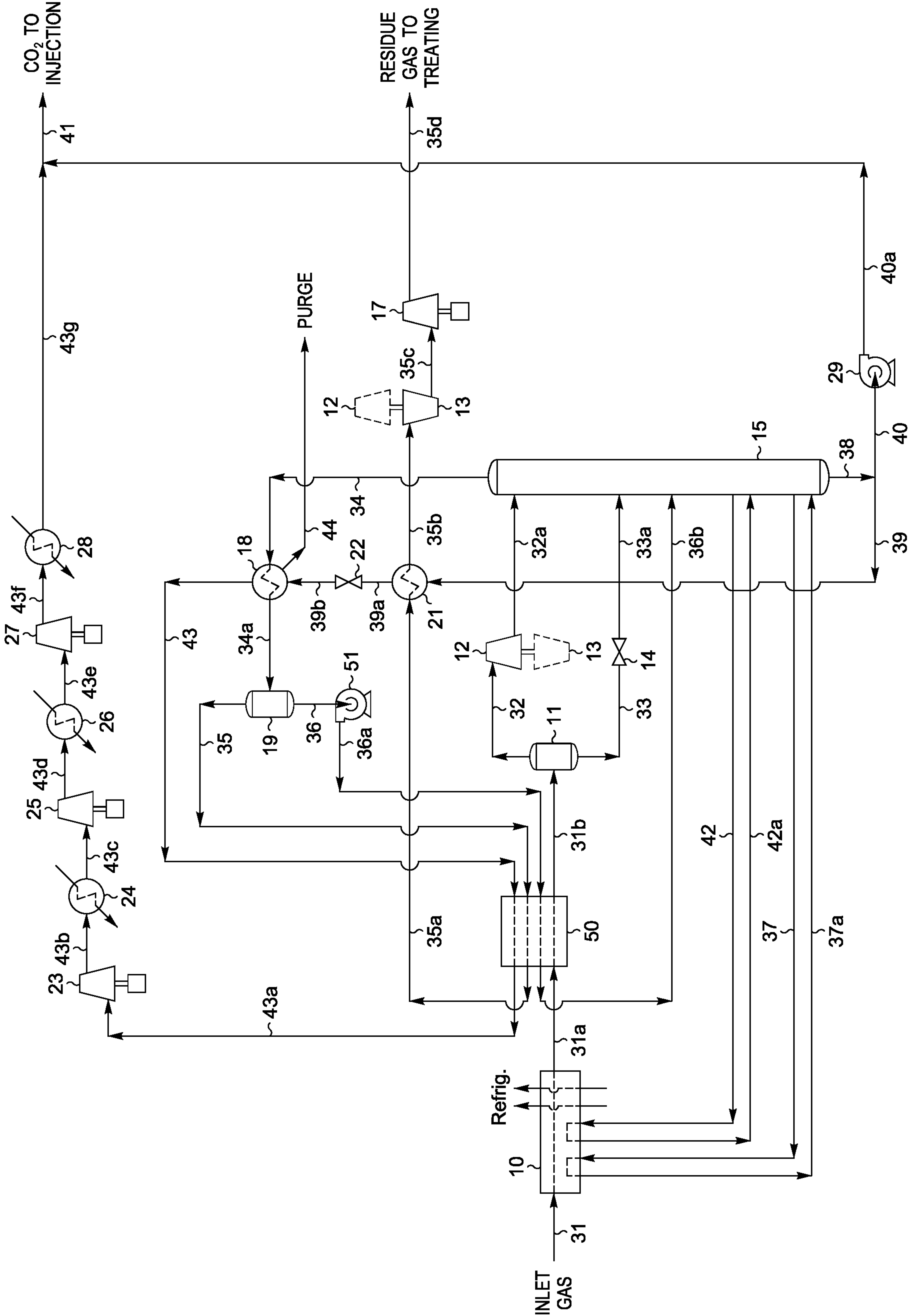

FIG. 1
(PRIOR ART)

