



US 20100233641A1

(19) **United States**

(12) **Patent Application Publication**  
**ROSZKOWSKI et al.**

(10) **Pub. No.: US 2010/0233641 A1**

(43) **Pub. Date: Sep. 16, 2010**

(54) **DEVICE FOR HEATING AIR DURING THE DUTY CYCLE OF A HEATING BOILER**

**Publication Classification**

(76) Inventors: **Stanislaw ROSZKOWSKI**,  
Chmielno (PL); **Bartosz**  
**ROSZKOWSKI**, Chmielno (PL)

(51) **Int. Cl.**  
*F23L 15/00* (2006.01)  
*F23B 99/00* (2006.01)  
*F23D 11/44* (2006.01)

(52) **U.S. Cl. .... 431/215; 110/234; 110/302; 110/312**

(57) **ABSTRACT**

Correspondence Address:  
**MATTHIAS SCHOLL**  
**14781 MEMORIAL DRIVE, SUITE 1319**  
**HOUSTON, TX 77079 (US)**

Device for heating air during the duty cycle of a heating boiler fired in particular by solid fuel or biomass, composed of a conduit for supplying air to the furnace and a conduit for outflow the exhaust gas from the heating boiler into the flue. The device has the closed exhaust gas conduit (2) which over the length of its connection with the flue (8) is shaped resembling a cosine curve with advantageously vertical exhaust gas conduits (4) adhered to the vertical air conduits (11) which over the length of the air conduit (3) have a shape resembling a sine curve, and on the last vertical conduit (5), where the end section (7) of the exhaust gas conduit (2) is guided to the flue (8), there is a pumping fan (6). The closed exhaust gas conduit (2) in the shape resembling a cosine curve has vertical exhaust gas conduits (4) which decrease in volume in the flue (8) direction, and the air conduit (3) in the shape resembling a sine curve has vertical air conduits (11) which increase in volume in the boiler (1) direction.

(21) Appl. No.: **12/722,555**

(22) Filed: **Mar. 12, 2010**

(30) **Foreign Application Priority Data**

Mar. 12, 2009 (PL) ..... P.387357

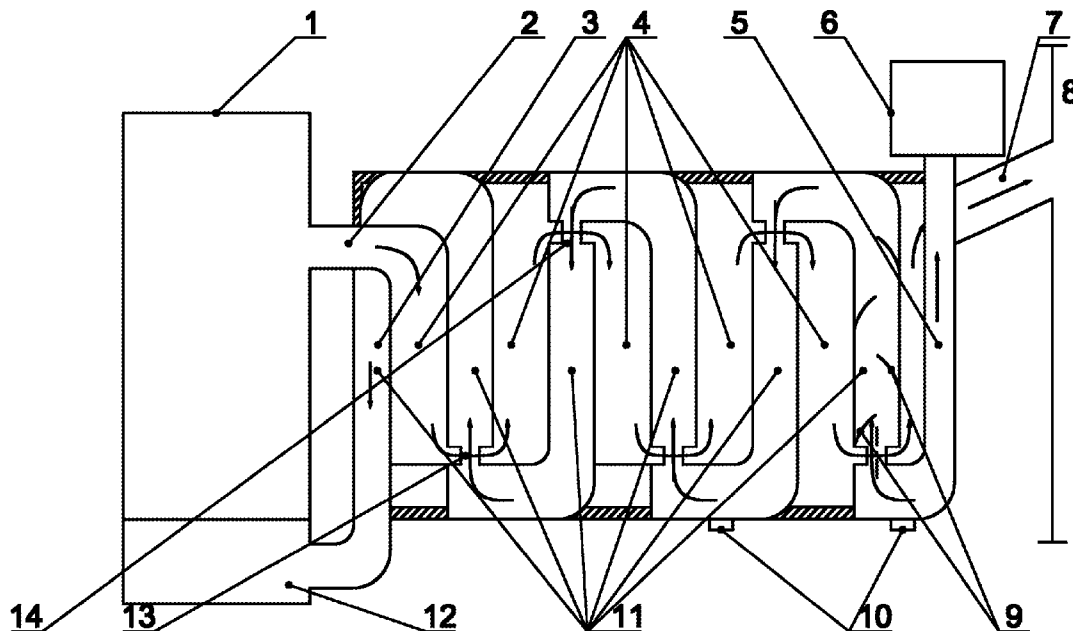

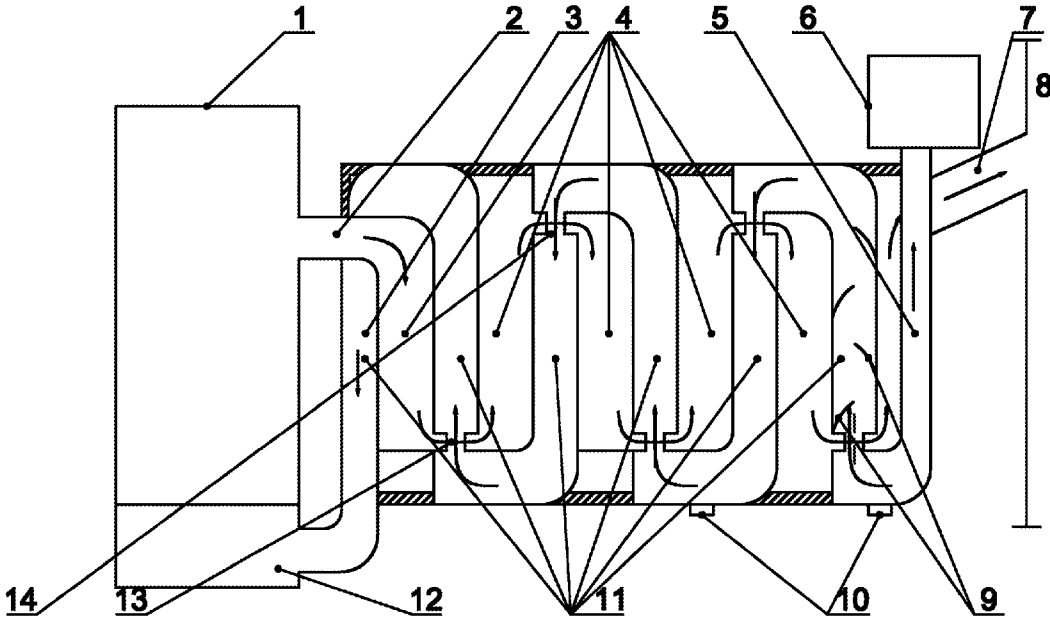

**DEVICE FOR HEATING AIR DURING THE  
DUTY CYCLE OF A HEATING BOILER****CROSS-REFERENCE TO RELATED  
APPLICATIONS**

[0001] Pursuant to 35 U.S.C §119 and the Paris Convention Treaty, this application claims the benefit of Polish Patent Application No. P 387357 filed Mar. 12, 2009, the contents of which are incorporated herein by reference.

**BACKGROUND OF THE INVENTION**

[0002] 1. Field of the Invention

[0003] The invention relates to a device for heating air during the duty cycle of a heating boiler, especially central heating water boilers fired by solid fuel or biomass.

[0004] 2. Description of the Related Art

[0005] Polish Pat. Appl. No. P. 378703 refers to an environmentally friendly central heating water boiler fired by solid fuels, especially wood and coal, designed for providing central heating in residential houses and other objects. The water jacket surrounding the combustion chamber, housed within the boiler's body, is additionally heated from the outside by exhaust gas which escapes through exhaust gas partitions surrounding the water jacket. The exhaust gas partitions are thermally insulated by chamotte bricks and mineral wool matings.

[0006] Another known device mentioned in Polish Pat. Appl. No. P. 380100 refers to a method of combustion and a combustion boiler which reduces the emission of nitrogen oxides in the exhaust gas from the solid fuel boiler with a retort burner by decreasing the temperature at the flame core. This is achieved using a stream of re-circulated exhaust gas, a mixture of exhaust gas and air, steam or a mixture of steam and air flowing to the retort burner or to the combustion chamber directly over the flame, pumped by a fan through a moving recirculation pipe, nozzles installed in the boiler's ceiling, or nozzles located around the retort burner, or through the combined solutions.

[0007] A water boiler for solid fuel, especially for biomass, known from Polish Pat. Appl. No. P. 381102, is fitted with a body and a vault housing a water jacket, under which the combustion chamber is located. The vault housing the water jacket is connected to the water chamber of the boiler's body. Lower arm sections of the body are fitted with conduits for a portion of overfire air, whose volume is adjusted by rotary flaps actuated by the lower electric stepper motor. The upper section of the recuperation combustion chamber is fitted with an inlet conduit for additional overfire air, whose volume is adjusted by a flap actuated by the upper electric stepper motor. The grate tubes located under the vault with the water jacket are cooled using water and cleaned by scrapers between the grate tubes driven by a linear electromagnetic drive unit. The exhaust gas collector is fitted with an oxygen probe which controls the stepper motors to ensure a very low level of toxic substances in the exhaust gas. To ensure ease of operation for the user, the boiler can be fitted with an automatic fuel feeder and a laser sensor for detecting whether a specific upper fuel level in the recuperation combustion chamber has been reached, as well as a second laser sensor for detecting whether the lower fuel level in the recuperation combustion chamber has been reached and for actuating the automatic fuel feeder.

[0008] Another known device mentioned in Polish Pat. Appl. No. P. 381355 refers to a central heating water boiler fitted with a system for supplying primary and overfire air to the combustion chamber. The system is composed of pumping nozzles on the boiler's sides. The nozzles work with a blow-in fan installed in the air conduit pumping the air into the area between the water jacket and the outer jacket. The pumping nozzles are in the form of fixed tubes installed between the walls of the water jacket and they connect the combustion chamber with the area between the water jacket and the outer jacket. The number of the pumping nozzles depends on the boiler's size and capacity.

[0009] Polish Pat. Appl. No. P. 368210 refers to a heating boiler fitted with a furnace chamber and a furnace, a blower for supplying compressed air and a fuel feeder. In the chamber's upper section, there is a heat exchanger in the shape of a boiler drum with internal rings formed by the fitted vertical exhaust pipes. The pipes located radially around the longitudinal axis of the heat exchanger and in the water jacket, with at least one external ring formed by exhaust pipes whose outlets are connected directly to the boiler's flue section and inlets located over the furnace chamber, below the outlets, forming at least one internal ring of exhaust pipes, whose inlets are located in the exhaust gas return chamber.

[0010] An device known from Polish Pat. Appl. No. P. 376356 refers to a water boiler fired with hard coal. The boiler is fitted with a heat exchanger with two retort furnaces supplied with fuel through the symmetrical and separate coal supply systems. The air required for the combustion process is supplied to the furnace through a symmetrical, double primary air system. The air supplied over the furnace comes through a symmetrical, double overfire air system. These systems are actuated by separated fans. The heat exchanger is connected to the exhaust gas fan through a multicyclone.

[0011] Another known device mentioned in Polish Pat. No. 196625 refers to exhaust gas boiler, especially fitted with a fan assembly, with a drive motor, suction fan installed on the rotary shaft of the drive motor, located in the suction conduit, ensuring forced induction of air from the room or from the outside, and an exhaust fan installed on the rotary shaft of the drive motor, located in the outlet conduit to ensure forced removal of exhaust gas outside. Thus, the air from the room or from the outside is forced into the intake conduit by the suction fan, and the exhaust gas is forced into the outlet conduit by the exhaust fan. The method ensures a constant air flow in the intake, combustion and outlet conduits.

[0012] A device known from Polish Pat. No. 192574 refers to a boiler with a retort furnace with an extended heating surface. The boiler is an environment-friendly device. It has a two-level furnace and an extended heating surface for producing heat from solid fuels. The two-level retort furnace is fitted with air slots, and the symmetrical construction of the collector allows the boiler to be supplied with fuel and air from the right side as well as the left side. The heat exchanger, composed of multiple parts, forms a single water unit and includes a lower section around the furnace, a middle section formed by the boiler drum with pipes, an upper section around the exhaust gas collector and an external part which forms passage pockets. The whole boiler is a uniform, welded construction.

[0013] Polish Pat. No. 188246 refers to a heating boiler with gasification, fired by solid fuel, especially wood. The heating boiler has a fuel and gasification chamber, with a cross-section in the shape of a pear, which converges in the

middle, in the peak line. In the peak line area and in the middle, there is a slotted grate with a length of approx.  $\frac{1}{5}$ - $\frac{1}{3}$  of the peak line. Over the grate, there are primary air inlet openings on both sides, at approx. 0.4-0.6 of the maximum height of the fuel and gasification chamber. Under the grate, a slotted combustion nozzle is installed. It is roughly equal in length to the grate and constitutes a connection with the combustion chamber. The combustion chamber is divided by a slightly inclined horizontal wall into pre-combustion and mixing chamber and a post-combustion chamber located underneath. The cross-section of both chambers resembles the shape of kidneys, widening in the flow direction. The pre-combustion and mixing chamber is supplied with overfire air supplied by the air supply pipe and air heater. At the outlet of the pre-combustion and mixing chamber, and at the inlet of the post-combustion chamber, there is a return and post-combustion chamber. Between the outlet of the post-combustion chamber and the exhaust gas lines, there is another post-combustion chamber, through which a supply pipe for overfire air is guided to the air heater.

#### SUMMARY OF THE INVENTION

**[0014]** The invention provides a device for heating air during the duty cycle of a heating boiler fired in particular by solid fuel or biomass, comprising a conduit for supplying air to the furnace and a conduit for outflow of the exhaust gas from the heating boiler into the flue, wherein the device has the closed exhaust gas conduit which over the length of its connection with the flue is in a shape resembling a cosine curve with advantageously vertical exhaust gas conduits adhered to the vertical air conduits which over the length of the air conduit have a shape resembling a sine curve, and on the last vertical conduit, where the end section of the exhaust gas conduit is guided to the flue, there is a pumping fan.

**[0015]** The closed exhaust gas conduit in the shape resembling a cosine curve has vertical exhaust gas conduits which decrease in volume in the flue direction, and the air conduit in the shape resembling a sine curve has vertical air conduits which increase in volume in the boiler direction. Inside the vertical air conduits there are air guides. The vertical air conduits, alternatingly in the bent sections, have lower and upper mesh connections which are advantageously shaped as cylindrical conduits. The air conduit is advantageously guided to the heating boiler's ash-pan. The vertical air conduits have condensate drain outlets in the lower section.

**[0016]** The device of the invention uses heat from the boiler's smoke conduit, from other gasses forced into the atmosphere during the combustion process as well as heat forced into the atmosphere from other devices, which is intended to be reused. The device as per the invention allows heat from the exhaust gas to be used for heating air supplied to the boiler's ash-pan.

**[0017]** The recovery of heat from the exhaust gas begins by being pumped through a separate air conduit in the direction opposite to the flow of hot gasses. The air conduit in the heat reversing mechanism starts absorbing heat from the outlet conduit of the exhaust gas into the flue and ends at the boiler's smoke conduit. Such a construction of the device and method of reusing heat from exhaust gas allows hot air to be supplied to the boiler's combustion chamber, leading to better boiler efficiency. Heat is re-introduced into the boiler through the ash-pan. It can be alternatively used for heating another heat exchanger or for heating rooms by air blow. The high heat recovery rate (90%) ensured by the device used in a house-

hold central heating boiler room provides fuel savings of 50-60%. This device can be used in industrial boiler rooms and for recovering heat from other devices which release used heat directly into the atmosphere.

**[0018]** At this time of combating climatic warming, the device may achieve a 90% reduction of exhaust gas and heat emission into the atmosphere by using a heat reversing mechanism. The device has undergone technical tests. It has applied in particular to a boiler room of in a single-family house and meets the requirements for reducing heat emission into the atmosphere.

#### BRIEF DESCRIPTION OF THE DRAWINGS

**[0019]** The invention is described hereinbelow with reference to accompanying drawings, in which the single FIGURE shows an exemplary embodiment of a device for heating air during the duty cycle of a heating boiler.

#### DETAILED DESCRIPTION OF THE INVENTION

##### Example

**[0020]** FIG. 1 shows in the device according to the invention, a conduit for supplying air **3** to the furnace of the heating boiler **1** and a conduit for outflow of the exhaust gas **2** from the heating boiler **1** into the flue **8**. The closed exhaust gas conduit **2** in the shape resembling a cosine curve and comprises a plurality of vertical exhaust gas conduits **4**. The air conduit **3** is in the shape resembling a sine curve and comprises a plurality of vertical air conduits **11**. The vertical exhaust gas conduits **4** adhere to the vertical air conduits **11**. A pumping fan **6** is disposed on the last vertical conduit **5**, where the end section **7** of the exhaust gas conduit **2** is guided to the flue **8**.

**[0021]** The vertical exhaust gas conduits **4** decrease in volume in the direction from the boiler towards the flue **8**. The vertical air conduits **11** increase in volume in the direction towards the boiler **1**. Air guides **9** are disposed inside the vertical air conduits **11**. The vertical air conduits **11** have lower mesh connections **13** and upper mesh connections **14** alternatingly in the bent sections. The lower mesh connections **13** and the upper mesh connections **14** are shaped as cylindrical conduits. The air conduit **3** is guided to the ash-pan **12** of heating boiler **1**. The vertical air conduits **11** in the lower section are fitted with drain outlets **10** for condensate produced as a result of the difference in temperature between the air and the exhaust gas.

**[0022]** This invention is not to be limited to the specific embodiments disclosed herein and modifications for various applications and other embodiments are intended to be included within the scope of the appended claims. While this invention has been described in connection with particular examples thereof, the true scope of the invention should not be so limited since other modifications will become apparent to the skilled practitioner upon a study of the drawings, specification, and following claims.

**[0023]** All publications and patent applications mentioned in this specification are indicative of the level of skill of those skilled in the art to which this invention pertains. All publications and patent applications mentioned in this specification are herein incorporated by reference to the same extent as if each individual publication or patent application mentioned in this specification was specifically and individually indicated to be incorporated by reference.

The invention claimed is:

1. A device for heating air during a duty cycle of a heating boiler with a furnace fired in particular by solid fuel or biomass, the device comprising:

a conduit for supplying air to the furnace comprising a plurality of substantially vertical air conduits;

a conduit for outflow of an exhaust gas from the heating boiler into a flue comprising a plurality of substantially vertical exhaust gas conduits; and

a pumping fan;

wherein

the conduit for outflow of an exhaust gas from the heating boiler into a flue has a shape resembling a cosine curve over the length of its connection from the heating boiler into a flue;

the conduit for supplying air to the furnace has a shape resembling a sine curve;

said vertical exhaust gas conduits adhere to said vertical air conduits; and

said pumping fan is located where an end section of one exhaust gas conduit is guided to the flue.

2. The device of claim 1, wherein said vertical exhaust gas conduits decrease in volume in the direction from the heating boiler to the flue, and said vertical air conduits increase in volume in the direction from the flue towards the heating boiler.

3. The device of claim 1, wherein air guides are disposed in said vertical air conduits.

4. The device of claim 1, wherein said vertical air conduits comprise bent sections; and have lower mesh connections and upper mesh connections disposed alternately in said bent sections.

5. The device of claim 4, wherein said lower mesh connections and said upper mesh connections have the shape of cylindrical conduits.

6. The device of claim 1, wherein said air conduit for supplying air to the furnace is directly connected to an ash pan of the heating boiler.

7. The device of claim 1, wherein said vertical air conduits comprise condensate drain outlets in their lower section.

\* \* \* \* \*