

(19)



(11)

EP 3 764 015 A1

(12)

EUROPEAN PATENT APPLICATION
published in accordance with Art. 153(4) EPC

(43) Date of publication:

13.01.2021 Bulletin 2021/02

(51) Int Cl.:

F24F 13/14^(2006.01) F24F 13/20^(2006.01)

(21) Application number: **18926700.8**

(86) International application number:

PCT/CN2018/123019

(22) Date of filing: **24.12.2018**

(87) International publication number:

WO 2020/015310 (23.01.2020 Gazette 2020/04)

(84) Designated Contracting States:

AL AT BE BG CH CY CZ DE DK EE ES FI FR GB GR HR HU IE IS IT LI LT LU LV MC MK MT NL NO PL PT RO RS SE SI SK SM TR

Designated Extension States:

BA ME

Designated Validation States:

KH MA MD TN

(72) Inventors:

- **CAI, Yanfang**
Qingdao, Shandong 266101 (CN)
- **ZHANG, Zhongxiao**
Qingdao, Shandong 266101 (CN)
- **WANG, Haisheng**
Qingdao, Shandong 266101 (CN)
- **CUI, Limin**
Qingdao, Shandong 266101 (CN)

(30) Priority: **20.07.2018 CN 201810804491**

(74) Representative: **dompatent von Kreisler Selting**

(71) Applicants:

- **Qingdao Haier Air-Conditioning Electronic Co., Ltd**
Qingdao, Shandong 266101 (CN)
- **Haier Smart Home Co., Ltd.**
Qingdao, Shandong 266101 (CN)

**Werner -
Partnerschaft von Patent- und Rechtsanwälten mbB
Deichmannhaus am Dom
Bahnhofsvorplatz 1
50667 Köln (DE)**

(54) **PANEL STRUCTURE OF AIR CONDITIONER AND AIR CONDITIONER**

(57) A panel structure of an air conditioner and the air conditioner, relating to the technical field of air conditioners. The problems that the panel structure of an existing air conditioner has inadequate strength and is easily deformed are solved. The panel structure of the air conditioner comprises: air guiding plates (1), a vertical swinging blade assembly (2) and a panel body (3). The air guiding plates (1) are provided with first micropore structures (11) penetrating through thickness directions of the air guiding plates, and the air guiding plates are driven by an air guiding plate motor to swing up and down. The vertical swinging blade assembly (2) comprises a swinging rod (21) and one or more vertical swinging blades (22) of bionic leaf structures, wherein the vertical swinging blades (22) are provided on the swinging rod (21), the swinging rod (21) is driven by a swinging rod drive motor to drive the vertical swinging blades (22) to swing leftwards and rightwards, and the vertical swinging blades (22) are provided with second micropore structures (221) penetrating through thickness directions of the vertical swinging blades. The panel body (3) is provided with reinforcing ribs (31).

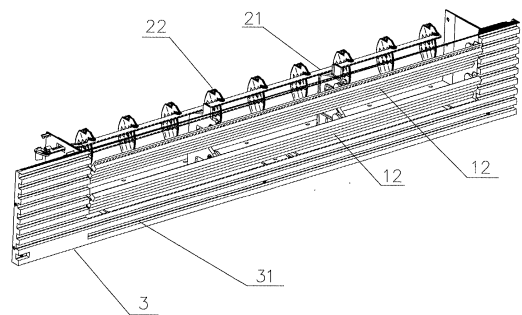

Fig. 11

EP 3 764 015 A1

Description

CROSS-REFERENCE TO RELATED APPLICATIONS

[0001] The application is based upon and claims priority to Chinese Patent Application No. 201810804491.3, filed July 20, 2018, the entire contents of which are incorporated herein by reference.

TECHNICAL FIELD

[0002] The present disclosure relates to the field of air conditioner technologies, and more particularly, to a panel structure of an air conditioner and an air conditioner.

BACKGROUND

[0003] With the continuous improvement of people's living standards, consumers have higher requirements on noise, comfort and appearance of existing air conditioners. In order to pursue the lightness and thinness of the air conditioners, a panel structure with light weight and thin thickness is used for the existing air conditioners as much as possible, which easily leads to insufficient strength of the panel structure of the air conditioners, easy deformation, decreased texture and short service life.

SUMMARY

[0004] Embodiments of the present disclosure provide a panel structure of an air conditioner and an air conditioner, aiming to solve the technical problem that the panel structure of the existing air conditioners has insufficient strength and is easily deformed. In order to basically understand some aspects of the disclosed embodiments, a brief summary is given below. The summary is not a general comment, nor tends to determine key/critical constituent elements or describe a protection scope of these embodiments, and only aims to present some concepts in a simplified form as an introduction of the following detailed description.

[0005] According to the embodiments of the present disclosure, there is provided a panel structure of an air conditioner and an air conditioner. By arranging the one or more reinforcing ribs on the panel body, the structural strength of the panel structure is improved, and the panel structure is not easily deformed.

[0006] According to a first aspect of the embodiments of the present disclosure, there is provided a panel structure of an air conditioner, including:

an air deflector provided with one or more first micropore structures penetrating through a thickness direction of the air deflector, and swinging up and down under the drive of a motor of the air deflector; a vertical swing blade assembly including a swing rod and one or more vertical swing blades with a

bionic leaf structure, wherein each vertical swing blade is arranged on the swing rod, the swing rod drives the vertical swing blade to swing left and right under the drive of a drive motor of the swing rod, and the vertical swing blade is provided with one or more second micropore structures penetrating through a thickness direction of the vertical swing blade; and a panel body provided with one or more reinforcing ribs.

[0007] In some optional technical solutions, a width of the vertical swing blade decreases from middle to both ends, and a peripheral edge of the vertical swing blade is streamlined.

[0008] In some optional technical solutions, each first micropore structure and/or each second micropore structure is configured as a structure in which cross-sectional areas of a plurality of cross sections increase from middle to both ends.

[0009] In some optional technical solutions, the one or more reinforcing ribs are configured as one or more first transverse reinforcing ribs along a length direction of the panel body and/or one or more first longitudinal reinforcing ribs along a width direction of the panel body.

[0010] In some optional technical solutions, a length of the one or more first transverse reinforcing ribs is equal to that of the panel body, and a length of the one or more first longitudinal reinforcing ribs is equal to a width of the panel body.

[0011] In some optional technical solutions, the air deflector is provided with one or more second transverse reinforcing ribs along a length direction of the air deflector and/or one or more second longitudinal reinforcing ribs along a width direction of the air deflector.

[0012] In some optional technical solutions, when the air deflector is closed, the one or more first transverse reinforcing ribs and the one or more second transverse reinforcing ribs are in the same straight line, and/or the one or more first longitudinal reinforcing ribs and the one or more second longitudinal reinforcing ribs are in the same straight line.

[0013] In some optional technical solutions, each second transverse reinforcing rib and/or each longitudinal reinforcing rib is provided with the first micropore structures.

[0014] In some optional technical solutions, the panel body includes a first part located around the panel body and a second part located in the middle of the panel body, a density of the first transverse reinforcing ribs in the first part is greater than that of the first transverse reinforcing ribs in the second part, and/or the density of the first longitudinal reinforcing ribs in the first part is greater than that of the first longitudinal reinforcing ribs in the second part.

[0015] According to a second aspect of the embodiments of the present disclosure, there is provided an air conditioner, including the panel structure described above.

[0016] The technical solutions provided by the embodiments of the present disclosure may include following beneficial effects:

1. the panel body is provided with one or more reinforcing rib, and thus the structural strength of the panel structure is improved, and the panel structure is not easily deformed.
2. the vertical swing blades are imitated the shape of leaves in nature, and are driven to swing left and right by the motor, so that air coming out of a volute is closer to natural wind; the air adjusted left and right by the vertical swing blades is then adjusted up and down by the air deflector with micropores, so that the air blown out by the air conditioner is softer and meets the requirements of human comfort.

[0017] It should be understood that both the foregoing general description and the following detailed description are exemplary and explanatory only and are not intended to limit the present disclosure.

BRIEF DESCRIPTION OF THE DRAWINGS

[0018] The accompanying drawings, which are incorporated in and constitute a part of this description, illustrate embodiments consistent with the present disclosure and, together with the description, serve to explain the principles of the present disclosure.

Fig. 1 is a structural schematic diagram illustrating a panel structure of an air conditioner according to an exemplary embodiment;

Fig. 2 is a front view of the panel structure shown in Fig. 1;

Fig. 3 is a side view of the panel structure shown in Fig. 1;

Fig. 4 is a structural schematic diagram of wind direction adjustment of the air deflector of the panel structure shown in Fig. 1;

Fig. 5 is a structural schematic diagram of the air deflector;

Fig. 6 is an enlarged view of the a structure A in Fig. 5;

Fig. 7 is a structural schematic diagram of a vertical swing blade;

Fig. 8 is a structural schematic diagram illustrating a panel structure of an air conditioner according to an exemplary embodiment;

Fig. 9 is a front view of the panel structure shown in Fig. 8;

Fig. 10 is a side view of the panel structure shown in Fig. 8;

Fig. 11 is a structural schematic diagram of wind direction adjustment of the air deflector of the panel structure shown in Fig. 8;

Fig. 12 is a structural schematic diagram illustrating a panel structure of an air conditioner according to an exemplary embodiment;

Fig. 13 is a front view of the panel structure shown in Fig. 12;

Fig. 14 is a side view of the panel structure shown in Fig. 12;

Fig. 15 is a structural schematic diagram of wind direction adjustment of the air deflector of the panel structure shown in Fig. 12;

Fig. 16 is a schematic flowchart illustrating a method for controlling an air conditioner according to an exemplary embodiment;

Fig. 17 is a schematic flowchart illustrating a method for controlling an air conditioner according to an exemplary embodiment;

Fig. 18 is a structural schematic diagram illustrating a device for controlling an air conditioner according to an exemplary embodiment;

Fig. 19 is a structural schematic diagram illustrating a panel structure of an air conditioner according to an exemplary embodiment;

Fig. 20 is a front view of the panel structure shown in Fig. 19;

Fig. 21 is a rear view of the panel structure shown in Fig. 19;

Fig. 22 is a side view of the panel structure shown in Fig. 19;

Fig. 23 is a structural schematic diagram illustrating a panel structure of an air conditioner according to an exemplary embodiment;

Fig. 24 is a front view of the panel structure shown in Fig. 23;

Fig. 25 is a rear view of the panel structure shown in Fig. 23;

Fig. 26 is a side view of the panel structure shown in Fig. 23;

Fig. 27 is a structural schematic diagram of a vertical swing blade;

Fig. 28 is a schematic flowchart illustrating a method for controlling an air conditioner according to an exemplary embodiment;

Fig. 29 is a schematic flowchart illustrating a method for controlling an air conditioner according to an exemplary embodiment;

Fig. 30 is a structural schematic diagram illustrating a device for controlling an air conditioner according to an exemplary embodiment;

Fig. 31 is a structural schematic diagram illustrating a panel structure of an air conditioner according to an exemplary embodiment;

Fig. 32 is a front view of the panel structure shown in Fig. 31;

Fig. 33 is a structural schematic diagram of wind direction adjustment of the air deflector of the panel structure shown in Fig. 31;

Fig. 34 is a structural schematic diagram illustrating a decorative plate according to an exemplary embodiment; and

Fig. 35 is a structural schematic diagram illustrating the assembly of a decorative plate and a panel body

according to an exemplary embodiment.

Description of reference signs:

[0019] 1-air deflector; 11-first micropore structure; 12-first air deflector; 13-second air deflector; 2-vertical swing blade assembly; 21-swing rod; 22-vertical swing blade; 221-second micropore structure; 222-clamping member; 223-rotating member; 3-panel body; 31-reinforcing rib; 4-panel frame; 5-gasket; 6-human body sensing device; 61-human body sensor; 7-decorative plate; 81-first obtaining module; 82-first control module; 83-second obtaining module; 84-second control module.

DETAILED DESCRIPTION

[0020] The following description and accompanying drawings fully illustrate the specific implementation solutions of the present disclosure so that a person skilled in the art can practice them. The embodiments merely represent possible changes. Unless otherwise specified explicitly, the individual component and function are optional and the operation sequence may be changed. Parts and characteristics of some implementation solutions may be included in or replace parts and characteristics of other implementation solutions. The scope of the implementation solutions of the present disclosure includes the whole scope of the claims and all available equivalents of the claims. As used herein, each implementation solution may be independently or generally expressed by "present disclosure", which is merely for convenience. As a matter of fact, if more than one disclosure is disclosed, it does not mean that the scope of the application is automatically limited to any single disclosure or disclosure concept. As used herein, terms such as "first" and "second" are merely for distinguishing one entity or operation from another entity or operation and do not require or imply any actual relationship or sequence among these entities or operations.

[0021] It should be noted that, descriptions related to "first", "second", and the like in the present disclosure are only for descriptive purposes, and cannot be understood as indicating or implying their relative importance or implicitly indicating the number of indicated technical features. Therefore, the features defined with "first" and "second" may explicitly or implicitly include at least one of the features.

[0022] In the description of the present disclosure, it should be noted that, terms "mount" and "connect" should be construed in a broad sense, unless otherwise indicated and limited. For example, the connection may be fixed connection, detachable connection or integral connection, the connection may be mechanical connection or electrical connection, the connection may be direct connection or indirect connection through an intermediate medium, also may be internal communication between two elements. For a person of ordinary skill in the art, specific meanings of the above terms may be understood

according to specific circumstances.

[0023] As used herein, each embodiment is described progressively, and contents focally described in each embodiment are different from those in other embodiments.

5 The same or similar parts among each of the embodiments may be referred to each other.

[0024] Figs. 1-4 are structural schematic diagrams illustrating a panel structure of an air conditioner according to an exemplary embodiment.

10 **[0025]** In this optional embodiment, there is provided a panel structure of an air conditioner, including:

an air deflector 1 provided with one or more first micropore structures 11 penetrating through a thickness direction of the air deflector 1, and swinging up and down under the drive of a motor of the air deflector 1; and

15

a vertical swing blade assembly 2 including a swing rod 21 and one or more vertical swing blades 22 with a bionic leaf structure, wherein each vertical swing blade 22 is arranged on the swing rod 21, the swing rod 21 drives the vertical swing blade 22 to swing left and right under the drive of a drive motor of the swing rod 21, and the vertical swing blade 22 is provided with one or more second micropore structures 221 penetrating through a thickness direction of the vertical swing blade 22.

20

25

[0026] In this optional embodiment, since the natural wind is generally softer after being decelerated by the green leaves, the vertical swing blade 22 is imitated the shape of leaves in natural, and is driven to swing left and right by the drive motor of the swing rod 21, so that the air coming out of a volute is closer to the natural wind under the action of the vertical swing blade 22; the air adjusted left and right by the vertical swing blade 22 is then adjusted up and down by the air deflector 1, so that the air blown out by the air conditioner is softer. At the same time, the air deflector 1 is provided with the first micropore structures 11, and the vertical swing blade 22 is provided with the second micropore structures 221, during the swinging of the air deflector 1 and the vertical swing blades 22, the air passing through the first micropore structures 11 or the second micropore structures 221 further disrupts the moving direction of the air, and reduces the speed of the air in a certain direction, and thus the air is cool but not cold, and warm but not hot, thereby improving the comfort of the human body.

30

35

40

45

[0027] In some optional embodiments, when there are a plurality of vertical swing blades 22, blade sizes of any two adjacent vertical swing blades 22 are different. When the air passing through one of the vertical swing blades 22 blows to a vertical swing blade 22 adjacent to the vertical swing blade 22, since the blade sizes of the two vertical swing blades 22 are different, the moving direction of the air is further changed, the speed of the air in a certain direction is reduced, and the air is softer.

50

55

[0028] In some optional embodiments, the blade sizes

of the plurality of vertical swing blades 22 decrease from a middle position to both sides of the swing rod 21; or, the blade sizes of the plurality of vertical swing blades 22 increase from the middle position to both sides of the swing rod 21. Optionally, the plurality of vertical swing blades 22 are configured as structures with similar shapes. By arranging the vertical swing blades 22 in a similar shape, and changing the blade sizes along the swing rod 21 stepwise, the moving direction of the air is continuously changed, therefore, the speed of the air in a certain direction can be reduced, and the air in a room is softer or meets the requirement of windless feeling.

[0029] In some optional embodiments, a value range of a maximum swing angle of the vertical swing blade is [40°, 160°]. Optionally, the maximum swing angle of the vertical swing blade 22 is 45°, 60°, 80° and 120°. If the maximum swing angle of the vertical swing blade 22 is too small, the adjustment range of the moving direction of the air coming out of the volute is too small; and if the maximum swing angle of the vertical swing blade 22 is too large, the adjustment frequency of the moving direction of the air coming out of the volute is too small, therefore, by setting the value range of the maximum swing angle of the vertical swing blade 22 to be [40°, 160°], the adjustment range and the adjustment frequency of the moving direction of the air coming out of the volute can be better balanced, and the effect of windless feeling is better.

[0030] In some optional embodiments, the panel structure further includes a gasket 5 arranged on an upper part of the vertical swing blade assembly 2, wherein a width of the gasket 5 is not less than a maximum width of the vertical swing blade 22. By arranging the gasket 5 on the upper part of the vertical swing blade assembly 2, the air can be prevented from being lost from the vertical swing blade assembly 2, so that all the air coming out of the volute can be used to adjust indoor temperature.

[0031] In some optional embodiments, the air deflector 1 includes a plurality of first air deflectors 12 arranged in parallel up and down along a panel body 3 of the panel structure, wherein the first air deflector 12 is provided with the one or more first micropore structures 11 penetrating through a thickness direction of the first air deflector 12. The plurality of first air deflectors 12 work together, so that the effect of wind direction adjustment is better. Further, since two adjacent first air deflectors 12 swing up and down in different directions, the wind direction of the air passing through the vertical swing blade assembly 2 can be further disrupted, so that the air blown out from the air conditioner is closer to the natural wind.

[0032] Figs. 5-6 are structural schematic diagrams illustrating the air deflector according to an exemplary embodiment.

[0033] In this optional embodiment, there is provided an air deflector 1 of the panel structure. Each of one or more first micropore structures 11 of the air deflector 1 is configured as a structure in which cross-sectional ar-

reas of a plurality of cross sections increase from middle to both ends.

[0034] Optionally, each of one or more second micropore structures 221 of the vertical swing blade 22 is configured as a structure in which cross-sectional areas of a plurality of cross sections increase from middle to both ends.

[0035] In this optional embodiment, the first micropore structure 11 of the air deflector 1 and/or the second micropore structure 221 of the vertical swing blade 22 is configured as the structure in which the plurality of cross sections increase from the middle to both ends, and the two ends of the micropore structure diverge outwards, which is not only beneficial for the structural process to die out, but also enables the air passing through the micropore structure to diverge outwards, and thus the direction of the air passing through the first micropore structure 11 and/or the second micropore structure 221 is different and closer to the natural wind.

[0036] Fig. 7 is a structural schematic diagram illustrating a vertical swing blade according to an exemplary embodiment.

[0037] In this optional embodiment, a width of the vertical swing blade 22 decreases from middle to both ends, and a peripheral edge of the vertical swing blade 22 is streamlined.

[0038] In this optional embodiment, since the natural wind is generally softer after being decelerated by the green leaves, by setting the vertical swing blade 22 in the shape of a bionic natural leaf with width decreasing from the middle to both ends, the air can be softer after being decelerated by the vertical swing leave 22. Further, by setting the peripheral edge of the vertical swing blade 22 to be streamlined, the resistance when the vertical swing blade 22 swings from side to side can be made smaller, and the air is softer.

[0039] In some optional embodiments, the vertical swing blade 22 is provided with a clamping member 222 and a rotating member 223, the vertical swing blade 22 is clamped and connected to the swing rod 21 through the clamping member 222, the vertical swing blade 22 is rotatably connected to a panel frame 4 of the panel structure through the rotating member 223, and the swing rod 21 drives the vertical swing blade 22 to swing left and right relative to the panel frame 4 under the drive of the drive motor of the swing rod 21. Specifically, the clamping member 222 includes a first groove matched with the swing rod 21, wherein the first groove is clamped with the swing rod 21. The rotating member 223 includes a second groove, wherein the panel frame 4 is provided with a protrusion matched with the second groove, the rotating member 223 drives the vertical swing blade 22 to rotate around the protrusion through the second groove, the swing rod 21 moves left and right under the drive of the drive motor of the swing rod 21, and the vertical swing blade 22 swings left and right around the protrusion under the drive of the swing rod 21. The vertical swing blade 22 is movably connected to the swing rod

21 and the panel frame 4 through the clamping member 222 and the rotating member 223 respectively, therefore, it is easy to assemble and disassemble.

[0040] In some optional embodiments, a value range of a ratio of a total area of the second micropore structure 221 of the vertical swing blade 22 to a total area of the vertical swing blade 22 is [45%, 85%]. Optionally, the ratio of the total area of the second micropore structure 221 of the vertical swing blade 22 to the total area of the vertical swing blade 22 is 60%, 75% and 78%. If the ratio of the total area of the second micropore structure 221 of the vertical swing blade 22 to the total area of the vertical swing blade 22 is too small, an air area of the air passing through the second micropore structure 221 is too small and air volume is insufficient; and if the ratio of the total area of the second micropore structure 221 of the vertical swing blade 22 to the total area of the vertical swing blade 22 is too large, the effect of breeze adjustment is poor, therefore, by setting the value range of the ratio of the total area of the second micropore structure 221 of the vertical swing blade 22 to the total area of the vertical swing blade 22 to be [45%, 85%], the air volume of the second micropore structure 221 and the effect of the breeze adjustment can be well balanced.

[0041] In some optional embodiments, a value range of a maximum width of the second micropore structure 221 is [5mm, 10mm]. Optionally, the maximum width of the second micropore structure 221 is 6mm, 7mm, 8mm and 9mm. By setting the value range of the maximum width of the second micropore structure 221 to [5mm, 10mm], the effect of the breeze adjustment is better.

[0042] In some optional embodiments, the thickness of the vertical swing blade 22 decreases from the center to the periphery, and a value range of the difference between the maximum thickness and the minimum thickness of the vertical swing blade 22 is [3mm, 8mm]. Optionally, the difference between the maximum thickness and the minimum thickness of the vertical swing blade 22 is 5mm, 6mm and 7mm. By setting the thickness of the vertical swing blade 22 to decrease from the center to the periphery, the firmness of the structure of the vertical swing blade 22 can be improved; at the same time, an air layer can be formed on a surface of the vertical swing blade 22, which further disturbs the moving direction of the air and makes the air softer.

[0043] Figs. 8-11 are structural schematic diagrams illustrating a panel structure of an air conditioner according to an exemplary embodiment.

[0044] In this optional embodiment, there is provided a panel structure of an air conditioner, including:

an air deflector 1 provided with one or more first micropore structures 11 penetrating through a thickness direction of the air deflector 1, and swinging up and down under the drive of a motor of the air deflector 1;

a vertical swing blade assembly 2 including a swing rod 21 and one or more vertical swing blades 22 with

a bionic leaf structure, wherein each vertical swing blade 22 is arranged on the swing rod 21, the swing rod 21 drives the vertical swing blade 22 to swing left and right under the drive of a drive motor of the swing rod 21, and the vertical swing blade 22 is provided with one or more second micropore structures 221 penetrating through a thickness direction of the vertical swing blade 22; and

a panel body 3 provided with one or more reinforcing ribs 31.

[0045] In this optional embodiment, on one hand, the panel body 3 is provided with one or more reinforcing ribs 31, and thus the structural strength of the panel structure is improved, and the panel body is not easily deformed; on the other hand, the vertical swing blades 22 are imitated the shape of leaves in natural, and are driven to swing left and right by the motor, so that the air coming out of a volute is closer to the natural wind under the action of the vertical swing blades 22. The air adjusted left and right by the vertical swing blades 22 is then adjusted up and down by the air deflector 1 with micropores, so that the air blown out by the air conditioner is softer and meets the requirements of human comfort.

[0046] In some optional embodiments, the reinforcing ribs are configured as one or more first transverse reinforcing ribs along a length direction of the panel body 3 and/or one or more first longitudinal reinforcing ribs along a width direction of the panel body 3. Optionally, the first transverse reinforcing ribs and/or the first longitudinal reinforcing ribs are configured as strip-shaped reinforcing ribs integrally formed with the panel body 3. The first transverse reinforcing ribs and/or the first longitudinal reinforcing ribs improve the overall strength of the panel body 3. Moreover, by arranging the strip reinforcing ribs, lines of the whole strip-shaped panel body 3 are simplified, and the structure of the panel body 3 is optimized.

[0047] In some optional embodiments, a length of the first transverse reinforcing ribs is equal to that of the panel body 3, and a length of the first longitudinal reinforcing ribs is equal to a width of the panel body 3. By arranging the first transverse reinforcing ribs to penetrate through the length direction of the panel body 3 and the first longitudinal reinforcing ribs to penetrate through the width direction of the panel body 3, the structure of the panel body 3 is more compact, and the processing technology is simpler.

[0048] In some optional embodiments, the air deflector 1 is provided with one or more second transverse reinforcing ribs along a length direction of the air deflector 1 and/or one or more second longitudinal reinforcing ribs along a width direction of the air deflector 1. The second transverse reinforcing ribs and/or the second longitudinal reinforcing ribs improve the overall strength of the air deflector 1, and lines of the whole strip-shaped air deflector 1 are simplified, thereby optimizing the structure of the air deflector 1.

[0049] In some optional embodiments, when the air

deflector 1 is closed, the first transverse reinforcing ribs and the second transverse reinforcing ribs are in the same straight line, and/or the first longitudinal reinforcing ribs and the second longitudinal reinforcing ribs are in the same straight line, therefore, the structural consistency of the panel structure is improved while improving the structural strength of the panel structure.

[0050] In some optional embodiments, each second transverse reinforcing rib and/or each longitudinal reinforcing rib is provided with the first micropore structures 11. The first micropore structures 11 are arranged to penetrate through a thickness direction of the second transverse reinforcing ribs and/or the second longitudinal reinforcing ribs, so as to play a role of breeze adjustment.

[0051] In some optional embodiments, the panel body 3 includes a first part located around the panel body 3 and a second part located in the middle of the panel body 3. The density of the first transverse reinforcing ribs in the first part is greater than that of the first transverse reinforcing ribs in the second part, and/or the density of the first longitudinal reinforcing ribs in the first part is greater than that of the first longitudinal reinforcing ribs in the second part. During the use of the panel structure, the periphery of the panel body 3 is more vulnerable to damage than the middle of the panel body 3, therefore, by setting the distribution density of the first transverse reinforcing ribs and/or the second transverse reinforcing ribs in the first part of the panel body 3 to be larger, the structural stability of the panel body 3 located in the first part can be further improved. For the panel body 3 located in the second part, the requirement of the structural strength is relatively low, therefore, by setting the distribution density of the first transverse reinforcing ribs and/or the second transverse reinforcing ribs in the second part of the panel body 3 to be smaller, the mass of the panel body 3 can be reduced, the processing technology of the panel body 3 can be simplified, and the production cost can be reduced.

[0052] Figs. 12-15 are structural schematic diagrams illustrating a panel structure of an air conditioner according to an exemplary embodiment.

[0053] In this optional embodiment, there is provided a panel structure of an air conditioner, including:

an air deflector 1 including a plurality of second air deflectors 13 arranged in parallel left and right along a panel body 3 of the panel structure, wherein each second air deflector 13 swings up and down under the drive by a motor of the air deflector 1, and the second air deflector 13 is provided with one or more first micropore structures 11 penetrating through a thickness direction of the second air deflector 13;
 a vertical swing blade assembly 2 including a swing rod 21 and one or more vertical swing blades 22 with a bionic leaf structure, wherein each vertical swing blade 22 is arranged on the swing rod 21, the swing rod 21 drives the vertical swing blade 22 to swing left and right under the drive of a drive motor of the

swing rod 21, and the vertical swing blade 22 is provided with one or more second micropore structures 221 penetrating through a thickness direction of the vertical swing blade 22;

a human body sensing device 6 used for sensing a human body position and transmitting human body position information to a controller of the air conditioner, so that the controller can control operation modes of the second air deflectors 13 and the vertical swing blades 22 according to the human body position information.

[0054] In this optional embodiment, on one hand, the air deflector 1 includes the plurality of second air deflectors 13 arranged in parallel left and right along the panel body 3 of the panel structure, and the operation modes of the second air deflectors 13 and the vertical swing blades 22 can be controlled according to the human body position information obtained by the human body sensing device 6, thereby realizing different air requirements at different positions of the air conditioner, and meeting different air requirements of users in different directions in the same room; on the other hand, the vertical swing blades 22 are imitated the shape of leaves in natural, and are driven to swing left and right by the motor, so that the air coming out of a volute is closer to the natural wind under the action of the vertical swing blades 22. The air adjusted left and right by the vertical swing blades 22 is then adjusted up and down by the air deflector with micropores, so that the air blown out by the air conditioner is softer and meets the requirements of human comfort.

[0055] In some optional embodiments, a human body sensor 61 of the human body sensing device 6 is embedded on the panel body 3. Optionally, the human body sensor 61 can be an infrared human body sensor 61. By embedding the human body sensor 61 on the panel body 3, the structure of the panel structure is more compact.

[0056] Fig. 16 is a schematic flowchart illustrating a method for controlling an air conditioner according to an exemplary embodiment.

[0057] In this optional embodiment, there is provided a method for controlling an air conditioner, including following steps:

S161, human body position information is obtained by using a human body sensing device; and
 S162, operation modes of one or more second air deflectors and one or more vertical swing blades are controlled according to the human body position information.

[0058] In this optional embodiment, the operation modes of the second air deflectors 13 and the vertical swing blades 22 are controlled according to the human body position information obtained by the human body sensing device 6, thereby realizing different air requirements at different positions of the air conditioner, and meeting different air requirements of the users in different

directions in the same room.

[0059] Fig. 17 is a schematic flowchart illustrating a method for controlling an air conditioner according to an exemplary embodiment.

[0060] In this optional embodiment, there is provided a method for controlling an air conditioner, including following steps.

[0061] S 171, human body position information is obtained by using a human body sensing device.

[0062] The human body position information is determined according to a human body position obtained by the human body sensing device 6.

[0063] S172, the human body position information is compared with prestored position area information to obtain a prestored position area where the human body position is located.

[0064] Areas that the human body sensing device 6 can sense are divided in advance, and the prestored position area where the human body position is located is obtained by comparing coordinate information in the human body position information with coordinate information in the prestored position area information.

[0065] For example, if the coordinate information in the human body position information is (5, 8, 6) and the coordinate information in the prestored position area information is (4-7, 7-9, 5-7), it can be determined that the human body position is in a prestored first position area.

[0066] S173, if the human body position is in the prestored first position area, second air deflectors located in a first side of a center of the panel structure are controlled to swing up and down, second air deflectors located in a second side of the center of the panel structure are controlled to close, and vertical swing blades are controlled to swing left and right.

[0067] When the human body position is in the prestored first position area, the second air deflectors 13 located in the first side of the center of the panel structure are controlled to swing up and down, the second air deflectors 13 located in the second side of the center of the panel structure are controlled to close, and the vertical swing blades 22 are controlled to swing left and right, so that a space located in the first side of the panel structure has uniform and large air volume, and a space located in the second side of the panel structure has a soft wind.

[0068] S174, if the human body position is in the prestored second position area, the second air deflectors located in the first side of the center of the panel structure are controlled to close, the second air deflectors located in the second side of the center of the panel structure are controlled to swing up and down, and the vertical swing blades are controlled to swing left and right.

[0069] When the human body position is in the prestored second position area, the second air deflectors 13 located in the first side of the center of the panel structure are controlled to close, the second air deflectors 13 located in the second side of the center of the panel structure are controlled to swing up and down, and the vertical swing blades 22 are controlled to swing left and right, so

that the space located in the first side of the panel structure has the soft wind, and the space located in the second side of the panel structure has the uniform and large air volume.

5 **[0070]** S175, if the human body position is in the prestored first position area and the prestored second position area, the second air deflectors are controlled to close, and the vertical swing blades are controlled to swing left and right.

10 **[0071]** When the human body position is in the prestored first position area and the prestored second position area, the second air deflectors 13 are controlled to close, and the vertical swing blades 22 are controlled to swing left and right, so that the wind in an entire space is soft.

15 **[0072]** S176, if the human body position is in the prestored first position area, the prestored second position area and a prestored third position area, the second air deflectors are controlled to swing up and down, and the vertical swing blades are controlled to swing left and right; or, the second air deflectors are controlled to erect laterally, and the vertical swing blades are controlled to erect.

20 **[0073]** When the human body position is in the prestored first position area, the prestored second position area and the prestored third position area, the second air deflectors 13 are controlled to swing up and down, and the vertical swing blades 22 are controlled to swing left and right; or, the second air deflectors 13 are controlled to erect laterally, and the vertical swing blades 22 are controlled to erect, so that the entire space has a large air volume.

25 **[0074]** In this optional embodiment, the prestored first position area corresponds to an area located in the second side of the center of the panel structure, the prestored second position area corresponds to an area located in the first side of the center of the panel structure, and the prestored third position area is a specific area, indicating that a human body density in the space is relatively high at this time. When the air conditioner detects that the human body is located in the prestored first position area, the wind in the area located in the second side of the center of the panel structure is soft; when the air conditioner detects that the human body is located in the prestored second position area, the wind in the area located in the first side of the center of the panel structure is soft; when the air conditioner detects that the human body is located in the prestored first position area and the prestored second position area, the wind in the entire space is soft; and when the air conditioner detects that the human body is located in the prestored first position area, the prestored second position area and the prestored third position area, the entire space has the large air volume, and thus different air requirements at different positions of the air conditioner are realized, and the air conditioner is more intelligent and flexible.

30 **[0075]** Fig. 18 is a structural schematic diagram illustrating a device for controlling an air conditioner accord-

ing to an exemplary embodiment.

[0076] In this optional embodiment, there is provided a device for controlling an air conditioner, including:

a first obtaining module 81 configured to obtain human body position information by using a human body sensing device 6; and
a first control module 82 configured to control operation modes of one or more second air deflectors 13 and one or more vertical swing blades 22 according to the human body position information.

[0077] In some optional embodiments, the first control module 82 is specifically configured to:

compare the human body position information with prestored position area information to obtain a prestored position area where the human body position is located;
if the human body position is in a prestored first position area, control second air deflectors 13 located in a first side of a center of the panel structure to swing up and down, control second air deflectors 13 located in a second side of the center of the panel structure to close, and control vertical swing blades 22 to swing left and right;
if the human body position is in a prestored second position area, control the second air deflectors 13 located in the first side of the center of the panel structure to close, control the second air deflectors 13 located in the second side of the center of the panel structure to swing up and down, and control the vertical swing blades 22 to swing left and right;
if the human body position is in the prestored first position area and the prestored second position area, control the second air deflectors 13 to close, and control the vertical swing blades 13 to swing left and right; and
if the human body position is in the prestored first position area, the prestored second position area and a prestored third position area, control the second air deflectors 13 to swing up and down, and control the vertical swing blades 22 to swing left and right; or, control the second air deflectors 13 to erect laterally, and control the vertical swing blades 22 to erect.

[0078] In some optional embodiments, there is provided a device for controlling an air conditioner, applied in the air conditioner, the device including:

a processor; and
a memory for storing instructions executable by the processor,
wherein the processor is configured to:
obtain human body position information by using a human body sensing device 6; and
control operation modes of one or more second air

deflectors 13 and one or more vertical swing blades 22 according to the human body position information.

[0079] Further, the processor is specifically configured to:

obtain human body position information by using the human body sensing device 6;
compare the human body position information with prestored position area information to obtain a prestored position area where the human body position is located;
if the human body position is in a prestored first position area, control second air deflectors 13 located in a first side of a center of the panel structure to swing up and down, control second air deflectors 13 located in a second side of the center of the panel structure to close, and control vertical swing blades 22 to swing left and right;
if the human body position is in a prestored second position area, control the second air deflectors 13 located in the first side of the center of the panel structure to close, control the second air deflectors 13 located in the second side of the center of the panel structure to swing up and down, and control the vertical swing blades 22 to swing left and right;
if the human body position is in the prestored first position area and the prestored second position area, control the second air deflectors 13 to close, and control the vertical swing blades 13 to swing left and right; and
if the human body position is in the prestored first position area, the prestored second position area and a prestored third position area, control the second air deflectors 13 to swing up and down, and control the vertical swing blades 22 to swing left and right; or, control the second air deflectors 13 to erect laterally, and control the vertical swing blades 22 to erect.

[0080] Figs. 19-22 are structural schematic diagrams illustrating a panel structure of an air conditioner according to an exemplary embodiment.

[0081] In this optional embodiment, there is provided a panel structure of an air conditioner, including:

an air deflector 1 provided with one or more first micropore structures 11 penetrating through a thickness direction of the air deflector 1, and swinging up and down under the drive of a motor of the air deflector 1; and
a plurality of vertical swing blade assemblies 2 arranged in parallel up and down along a panel body 3 of the panel structure, wherein each of the plurality of vertical swing blade assemblies 2 includes a swing rod 21 and one or more vertical swing blades 22 with a bionic leaf structure, wherein each vertical swing blade 22 is arranged on the swing rod 21, the swing

rod 21 drives the vertical swing blade 22 to swing left and right under the drive of a drive motor of the swing rod 21, and the vertical swing blade 22 is provided with one or more second micropore structures 221 penetrating through a thickness direction of the vertical swing blade 22.

[0082] In this optional embodiment, the vertical swing blades 22 are imitated the shape of leaves in natural, and a plurality of rows of vertical swing blades 22 are driven to swing left and right by the motor. After passing through an evaporator, the air coming out of the air conditioner is adjusted left and right through the plurality of rows of vertical swing blades 22, and then is adjusted up and down by the air deflector 1 with micropores. By changing the wind direction and wind speed for many times, the air is more comfortable and is closer to the natural wind, the noise of the air is lower, and the user experience is better.

[0083] In some optional embodiments, the vertical swing blades 22 of any two adjacent vertical swing blade assemblies 2 are arranged in a staggered manner. By arranging the vertical swing blades 22 of any two adjacent vertical swing blade assemblies 2 in the staggered manner, the air passing through one of the vertical swing blades 22 is further decelerated and changed direction after flowing through the vertical swing blade 22 adjacent to the vertical swing blade 22, so that the movement direction of the air is more chaotic, thereby achieving the purpose of windless feeling.

[0084] In some optional embodiments, blade sizes of the vertical swing blades 22 of any two adjacent vertical swing blade assemblies 2 are different. When the air passing through one of the vertical swing blades 22 blows to the vertical swing blade 22 adjacent to the vertical swing blade 22, since the blade sizes of the two vertical swing blades 22 are different, the moving direction of the air is further changed, the speed of the air in a certain direction is reduced, and the air is softer.

[0085] In some optional embodiments, a distance between two adjacent vertical swing blades 22 decreases from a middle position to both sides of the swing rod 21; or, the distance between two adjacent vertical swing blades 22 increases from the middle position to both sides of the swing rod 21. The distance between two adjacent vertical swing blades 22 is gradually changed. When each vertical swing blade 22 swings left and right, the air coming out of a volute unevenly passes through the vertical swing blade 22, so that the direction and size of the air passing through the vertical swing blade 22 are different, and thus the air is softer.

[0086] Optionally, the distance between two adjacent vertical swing blades 22 meets the following relationship:

$$d=1.7*L(n-1)/[n*(N-1)],$$

wherein L is a length of the swing rod 21, N is the number of vertical swing blades 22 located on the swing rod 21, n is a number of the distance between two adjacent vertical swing blades 22 from a central position of the swing rod 21, and d is the distance between two adjacent vertical swing blades 22 in the nth segment.

[0087] Specifically, n is an integer number starting from the central position of the swing rod 21 and increasing from an integer 2, for example 2, 3, 4, 5, and the like.

[0088] When the distance between two adjacent vertical swing blades 22 increases according to the above-mentioned relationship, and when each vertical swing blade 22 swings left and right, the direction of the air coming out of the volute is more chaotic after passing through the vertical swing blade 22, and thus the air is softer, and the structure of the vertical swing blade 22 is more reasonable and compact.

[0089] Figs. 23-26 are structural schematic diagrams illustrating a panel structure of an air conditioner according to an exemplary embodiment.

[0090] In this optional embodiment, there is provided a panel structure of an air conditioner, including:

an air deflector 1 provided with one or more first micropore structures 11 penetrating through a thickness direction of the air deflector 1, and swinging up and down under the drive of a motor of the air deflector 1; and

a vertical swing blade assembly 2 including a swing rod 21 and one or more vertical swing blades 22, wherein each vertical swing blade 22 is arranged on the swing rod 21, the swing rod 21 drives the vertical swing blade 22 to swing left and right under the drive of a drive motor of the swing rod 21, and the vertical swing blade 22 is provided with one or more second micropore structures 221 penetrating through a thickness direction of the vertical swing blade 22.

[0091] In this optional embodiment, the vertical swing blade 22 is driven to swing left and right by the motor to adjust the air coming out of a volute, and the air adjusted left and right by the vertical swing blade 22 is then adjusted up and down by the air deflector 1 with micropores. Through the vertical swing blade 22, the air deflector 1 and the micropore structure, the air blown out by the air conditioner is closer to the natural wind, and is clean and healthy, thereby improving the human comfort.

[0092] Fig. 27 is a structural schematic diagram illustrating a vertical swing blade according to an exemplary embodiment.

[0093] In some optional embodiment, the vertical swing blade 22 is configured as a structure including a plurality of parallel sub-blades, and the second micropore structures 221 on any two adjacent sub-blades are arranged in a staggered manner. By changing the direction of the air passing through the vertical swing blade 22 among the sub-blades of the vertical swing blade 22, and making the air pass through the second micropore struc-

tures 221 staggered with each other, the movement direction of the air is further disrupted, so that the air passing through the vertical swing blades 22 is chaotic and close to the natural wind, thereby improving the user experience.

[0094] In some optional embodiments, a rotatable blade is arranged in each second micropore structure 221, and the blade rotates under the action of an external air. Driven by the rotation of the blades, the direction of the air passing through the second micropore structures 221 is obviously changed, that is, the direction of the air is completely disrupted, so that the air passing through the vertical swing blades 22 is more chaotic and close to the natural wind, thereby meeting the requirement of windless feeling and having a good user experience.

[0095] In some optional embodiments, the vertical swing blade 22 has a triangular structure, and the peripheral edge of the triangular structure is streamlined, thereby having high stability and small swing resistance.

[0096] Fig. 28 is a schematic flowchart illustrating a method for controlling an air conditioner according to an exemplary embodiment.

[0097] In this optional embodiment, there is provided a method for controlling an air conditioner, including following steps:

S281, an operating mode of the air conditioner is obtained; and

S282, operation modes of the air deflector and the vertical swing blade are controlled according to the operating mode.

[0098] In this optional embodiment, different operation modes of the air deflector 1 and the vertical swing blades 22 can be controlled according to the operating mode of the air conditioner, thereby realizing the control of different operating modes of the air conditioner, which is flexible and convenient.

[0099] Fig. 29 is a schematic flowchart illustrating a method for controlling an air conditioner according to an exemplary embodiment.

[0100] In this optional embodiment, there is provided a method for controlling an air conditioner, including following steps.

[0101] S291, an operating mode of the air conditioner is obtained.

[0102] S292, if the operating mode is a uniform and large air volume operating mode, an air deflector is controlled to swing up and down, and vertical swing blades are controlled to swing left and right.

[0103] The air adjusted left and right by the vertical swing blades 22 is blown out after being adjusted up and down by the air deflector 1, and thus the air conditioner can operate with the uniform and large air volume operating mode.

[0104] S293, if the operating mode is a soft and small air volume operating mode, the air deflector is controlled to swing up and down, and the vertical swing blades are

controlled to close.

[0105] The breeze passing through the second micropore structures 221 of the vertical swing blades 22 is blown out after being adjusted up and down by the air deflector 1, and thus the air conditioner can operate with the soft and small air volume operating mode.

[0106] S294, if the operating mode is a soft and large air volume operating mode, the air deflector is controlled to close, and the vertical swing blades are controlled to swing left and right.

[0107] The air adjusted left and right by the vertical swing blades 22 is blown out through first micropore structures 11 of the air deflector 1, and thus the air conditioner can operate with the soft and large air volume operating mode.

[0108] S295, if the operating mode is a soft breeze operating mode, the air deflector is controlled to close, and the vertical swing blades are controlled to close.

[0109] The breeze passing through the second micropore structures 221 of the vertical swing blades 22 is blown out through the first micropore structures 11 of the air deflector 1, and thus the air conditioner can operate with the soft breeze operating mode.

[0110] S296, if the operating mode is a large air volume operating mode, the air deflector is controlled to erect laterally, and the vertical swing blades are controlled to erect.

[0111] By controlling the vertical swing blades 22 to erect laterally, and controlling the air deflector 1 to erect, the air blown out from a volute of the air conditioner blows out directly, and thus the air conditioner can operate with the large air volume operating mode.

[0112] In this optional embodiment, the different operation modes of the air deflector 1 and the vertical swing blades 22 can be controlled according to the operating mode of the air conditioner, thereby realizing the control of the different operating modes of the air conditioner, and meeting the requirements of the users for the different operating modes of the air conditioner.

[0113] Fig. 30 is a structural schematic diagram illustrating a device for controlling an air conditioner according to an exemplary embodiment.

[0114] In this optional embodiment, there is provided a device for controlling an air conditioner, including:

a second obtaining module 83 configured to obtain an operating mode of the air conditioner; and

a second control module 84 configured to control operation modes of the air deflector 1 and the vertical swing blades 22 according to the operating mode.

[0115] Further, the second control module 84 is specifically configured to:

if the operating mode is a uniform and large air volume operating mode, the air deflector 1 is controlled to swing up and down, and the vertical swing blades 22 are controlled to swing left and right;

if the operating mode is a soft and small air volume operating mode, the air deflector 1 is controlled to swing up and down, and the vertical swing blades 22 are controlled to close;

if the operating mode is a soft and large air volume operating mode, the air deflector 1 is controlled to close, and the vertical swing blades 22 are controlled to swing left and right;

if the operating mode is a soft breeze operating mode, the air deflector 1 is controlled to close, and the vertical swing blades 22 are controlled to close; and

if the operating mode is a large air volume operating mode, the air deflector 1 is controlled to erect laterally, and the vertical swing blades 22 are controlled to erect.

[0116] In some optional embodiments, there is provided a device for controlling an air conditioner, applied in the air conditioner, the device including:

- a processor; and
 - a memory for storing instructions executable by the processor,
- wherein the processor is configured to:
- obtain an operating mode of the air conditioner; and
 - control operation modes of the air deflector 1 and the vertical swing blades 22 according to the operating mode.

[0117] Further, the processor is specifically configured to:

- obtain an operating mode of the air conditioner;
- if the operating mode is a uniform and large air volume operating mode, the air deflector 1 is controlled to swing up and down, and the vertical swing blades 22 are controlled to swing left and right;
- if the operating mode is a soft and small air volume operating mode, the air deflector 1 is controlled to swing up and down, and the vertical swing blades 22 are controlled to close;
- if the operating mode is a soft and large air volume operating mode, the air deflector 1 is controlled to close, and the vertical swing blades 22 are controlled to swing left and right;
- if the operating mode is a soft breeze operating mode, the air deflector 1 is controlled to close, and the vertical swing blades 22 are controlled to close; and
- if the operating mode is a large air volume operating mode, the air deflector 1 is controlled to erect laterally, and the vertical swing blades 22 are controlled to erect.

[0118] Figs. 31-33 are structural schematic diagrams illustrating a panel structure of an air conditioner according to an exemplary embodiment.

[0119] In this optional embodiment, there is provided a panel structure of an air conditioner, including:

- 5 a panel body 3 provided with one or more first transverse reinforcing ribs along a length direction of the panel body 3 and/or one or more first longitudinal reinforcing ribs along a width direction of the panel body 3;
- 10 an air deflector 1 including a plurality of second air deflectors 13 arranged in parallel left and right along the panel body 3, wherein each second air deflector 13 swings up and down under the drive by a motor of the air deflector 1, and the second air deflector 13 is provided with one or more first micropore structures 11 penetrating through a thickness direction of the second air deflector 13; and
- 15 a vertical swing blade assembly 2 including a swing rod 21 and one or more vertical swing blades 22 with a bionic leaf structure, wherein each vertical swing blade 22 is arranged on the swing rod 21, the swing rod 21 drives the vertical swing blade 22 to swing left and right under the drive of a drive motor of the swing rod 21, and the vertical swing blade 22 is provided with one or more second micropore structures 221 penetrating through a thickness direction of the vertical swing blade 22.
- 20
- 25

[0120] In this optional embodiment, the panel body 3 is provided with one or more first transverse reinforcing ribs along the length direction of the panel body 3 and/or one or more first longitudinal reinforcing ribs along the width direction of the panel body 3, and thus the structural strength of the panel structure is improved, and the panel body is not easily deformed. And, the vertical swing blades 22 are imitated the shape of leaves in natural, and are driven to swing left and right by the motor, so that the air coming out of a volute is closer to the natural wind under the action of the vertical swing blades 22. The air adjusted left and right by the vertical swing blades 22 is then adjusted up and down by the air deflector 1 with micropores, so that the air blown out by the air conditioner is softer and meets the requirements of human comfort. In addition, the air deflector 1 includes the plurality of second air deflectors 13 arranged in parallel left and right along the panel body 3, by controlling the different operation modes of the second air deflector 13 and the vertical swing blades 22, different air requirements at different positions of the air conditioner can be realized, and different air requirements of the users in different directions in the same room can be met.

[0121] In some optional embodiments, the second air deflector 13 is provided with one or more second transverse reinforcing ribs along a length direction of the second air deflector 13 and/or one or more second longitudinal reinforcing ribs along a width direction of the second air deflector 13. The second transverse reinforcing ribs and/or the second longitudinal reinforcing ribs improve the overall strength of the second air deflector 13, and

optimize the structure of the second air deflector 13.

[0122] In some optional embodiments, a length of the second transverse reinforcing ribs is equal to that of the second air deflector 13, and a length of the second longitudinal reinforcing ribs is equal to a width of the second air deflector 13. By arranging the second transverse reinforcing ribs to penetrate through the length direction of the second air deflector 13 and the second longitudinal reinforcing ribs to penetrate through the width direction of the second air deflector 13, the structure of the second air deflector 13 is more compact, and the processing technology is simpler.

[0123] In some optional embodiments, the panel structure further includes a human body sensing device 6 used for sensing a human body position and transmitting human body position information to a controller of the air conditioner, so that the controller can control operation modes of the second air deflector 1 and the vertical swing blades 22 according to the human body position information. The operation modes of the second air deflector 13 and the vertical swing blades 22 can be controlled according to the human body position information obtained by the human body sensing device 6, thereby realizing different air requirements at different positions of the air conditioner, and meeting different air requirements of users in different directions in the same room.

[0124] Fig. 34 and Fig. 35 are structural schematic diagrams illustrating a decorative plate according to an exemplary embodiment.

[0125] In this optional embodiment, there is provided a decorative plate 7 installed with the panel body 3, wherein the decorative plate 7 is provided with one or more third transverse reinforcing ribs along a length direction of the decorative plate 7 and/or one or more third longitudinal reinforcing ribs along a width direction of the decorative plate 7. The third transverse reinforcing ribs and/or the third longitudinal reinforcing ribs improve the overall strength of the decorative plate 7, and optimize the structure of the decorative plate 7, wherein the decorative plate plays a role in protecting the panel body.

[0126] In some optional embodiments, when the decorative plate 7 is installed with the panel body 3, the first transverse reinforcing ribs and the third transverse reinforcing ribs are in the same straight line, and/or the first longitudinal reinforcing ribs and the third longitudinal reinforcing ribs are in the same straight line, therefore, the structural consistency of the panel structure is improved while improving the structural strength of the panel structure.

[0127] Further, when the decorative plate 7 is installed with the panel body 3, the first transverse reinforcing ribs overlap with the third transverse reinforcing ribs, and/or the first longitudinal reinforcing ribs overlap with the third longitudinal reinforcing ribs, so that the structure is more compact.

[0128] In some optional embodiments, there is provided a panel structure of an air conditioner, including:

an air deflector 1 provided with one or more first micropore structures 11 penetrating through a thickness direction of the air deflector 1, and swinging up and down under the drive of a motor of the air deflector 1; and

a horizontal swing blade assembly including a swing rod 21 and one or more horizontal swing blades with a bionic leaf structure, wherein each horizontal swing blade is arranged on the swing rod 21, the swing rod 21 drives the horizontal swing blade to swing up and down under the drive of a drive motor of the swing rod 21, and the horizontal swing blade is provided with one or more second micropore structures 221 penetrating through a thickness direction of the horizontal swing blade.

[0129] In this optional embodiment, since the natural wind is generally softer after being decelerated by the green leaves, the horizontal swing blade is imitated the shape of leaves in natural, and is driven to swing left and right by the drive motor of the swing rod 21, so that the air coming out of a volute is closer to the natural wind under the action of the horizontal swing blade; the air adjusted up and down by the horizontal swing blade is then adjusted left and right by the air deflector 1, so that the air blown out by the air conditioner is softer. At the same time, the air deflector 1 is provided with the first micropore structures 11, and the horizontal swing blade is provided with the second micropore structures 221, during the swinging of the air deflector 1 and the horizontal swing blades, the air passing through the first micropore structures 11 or the second micropore structures 221 further disrupts the moving direction of the air, and reduces the speed of the air in a certain direction, and thus the air is cool but not cold, and warm but not hot, thereby improving the comfort of the human body.

[0130] Optionally, a width of the horizontal swing blade decreases from middle to both ends, and a peripheral edge of the horizontal swing blade is streamlined.

[0131] Optionally, when there are a plurality of horizontal swing blades, blade sizes of any two adjacent horizontal swing blades are different.

[0132] Optionally, blade sizes of the plurality of horizontal swing blades 21 decrease from a middle position to both sides of the swing rod; or, the blade sizes of the plurality of horizontal swing blades 21 increase from the middle position to both sides of the swing rod.

[0133] Specifically, the distance between two adjacent horizontal swing blades meets the following relationship:

$$d=1.7*L(n-1)/[n*(N-1)],$$

wherein L is a length of the swing rod 21, N is the number of horizontal swing blades located on the swing rod 21, n is a number of the distance between two adjacent horizontal swing blades from a central position of the swing

rod 21, and d is the distance between two adjacent horizontal swing blades in the nth segment.

[0134] Specifically, n is an integer number starting from the central position of the swing rod 21 and increasing from an integer 2, for example 2, 3, 4, 5, and the like.

[0135] Optionally, the horizontal swing blade is provided with a clamping member 222 and a rotating member 223, the horizontal swing blade is clamped and connected to the swing rod 21 through the clamping member 222, the horizontal swing blade is rotatably connected to a panel frame 4 of the panel structure through the rotating member 223, and the swing rod 21 drives the horizontal swing blade to swing up and down relative to the panel frame 4 under the drive of the drive motor of the swing rod 21.

[0136] Optionally, a value range of a maximum swing angle of the horizontal swing blade is [40°, 160°].

[0137] Optionally, the air deflector 1 includes a plurality of first air deflectors 12 arranged in parallel left and right along the panel body 3 of the panel structure, wherein the first air deflector 12 is provided with the one or more first micropore structures 11 penetrating through a thickness direction of the first air deflector 21.

[0138] In some optional embodiments, there is provided a panel structure of an air conditioner, including:

an air deflector 1 provided with one or more first micropore structures 11 penetrating through a thickness direction of the air deflector 1, and swinging up and down under the drive of a motor of the air deflector 1;

a horizontal swing blade assembly including a swing rod 21 and one or more horizontal swing blades with a bionic leaf structure, wherein each horizontal swing blade is arranged on the swing rod 21, the swing rod 21 drives the horizontal swing blade to swing up and down under the drive of a drive motor of the swing rod 21, and the horizontal swing blade is provided with one or more second micropore structures 221 penetrating through a thickness direction of the horizontal swing blade; and

a panel body 3 provided with one or more reinforcing ribs 31.

[0139] In some optional embodiments, there is provided a panel structure of an air conditioner, including:

an air deflector 1 including a plurality of second air deflectors 13 arranged in parallel left and right along a panel body 3 of the panel structure, wherein each second air deflector 13 swings left and right under the drive by a motor of the air deflector 1, and the second air deflector 13 is provided with one or more first micropore structures 11 penetrating through a thickness direction of the second air deflector 13;

a horizontal swing blade assembly including a swing rod 21 and one or more horizontal swing blades with a bionic leaf structure, wherein each horizontal swing

blade is arranged on the swing rod 21, the swing rod 21 drives the horizontal swing blade to swing up and down under the drive of a drive motor of the swing rod 21, and the horizontal swing blade is provided with one or more second micropore structures 221 penetrating through a thickness direction of the horizontal swing blade; and

a human body sensing device 6 used for sensing a human body position and transmitting human body position information to a controller of the air conditioner, so that the controller can control operation modes of the second air deflector 1 and the horizontal swing blades according to the human body position information.

[0140] In some optional embodiments, there is provided a method for controlling an air conditioner, including following steps:

obtaining human body position information by using a human body sensing device 6; and controlling operation modes of one or more second air deflectors 13 and one or more horizontal swing blades according to the human body position information.

[0141] Optionally, the controlling operation modes of one or more second air deflectors 13 and one or more horizontal swing blades according to the human body position information includes:

comparing the human body position information with prestored position area information to obtain a prestored position area where the human body position is located;

if the human body position is in a prestored first position area, controlling second air deflectors 13 located in a first side of a center of the panel structure to swing left and right, controlling second air deflectors 13 located in a second side of the center of the panel structure to close, and controlling the horizontal swing blades to swing up and down;

if the human body position is in a prestored second position area, controlling the second air deflectors 13 located in the first side of the center of the panel structure to close, controlling the second air deflectors 13 located in the second side of the center of the panel structure to swing left and right, and controlling the horizontal swing blades to swing up and down;

if the human body position is in the prestored first position area and the prestored second position area, controlling the second air deflectors 13 to close, and controlling the horizontal swing blades 13 to swing up and down; and

if the human body position is in the prestored first position area, the prestored second position area and a prestored third position area, controlling the

5

10

15

20

25

30

35

40

45

50

55

second air deflectors 13 to swing left and right, and controlling the horizontal swing blades to swing up and down; or, controlling the second air deflectors 13 to erect, and controlling the horizontal swing blades to erect laterally.

[0142] In some optional embodiments, there is provided a device for controlling an air conditioner, including:

a third obtaining module configured to obtain human body position information by using a human body sensing device 6; and
a third control module configured to control operation modes of one or more second air deflectors 13 and one or more horizontal swing blades according to the human body position information.

[0143] Optionally, the third control module is specifically configured to:

compare the human body position information with prestored position area information to obtain a prestored position area where a human body position is located;
if the human body position is in a prestored first position area, control second air deflectors 13 located in a first side of a center of the panel structure to swing left and right, control second air deflectors 13 located in a second side of the center of the panel structure to close, and control horizontal swing blades to swing up and down;
if the human body position is in a prestored second position area, control the second air deflectors 13 located in the first side of the center of the panel structure to close, control the second air deflectors 13 located in the second side of the center of the panel structure to swing left and right, and control the horizontal swing blades to swing up and down;
if the human body position is in the prestored first position area and the prestored second position area, control the second air deflectors 13 to close, and control the horizontal swing blades 13 to swing up and down; and
if the human body position is in the prestored first position area, the prestored second position area and a prestored third position area, control the second air deflectors 13 to swing left and right, and control the horizontal swing blades to swing up and down; or, control the second air deflectors 13 to erect, and control the horizontal swing blades to erect laterally.

[0144] In some optional embodiments, there is provided a panel structure of an air conditioner, including:

an air deflector 1 provided with one or more first micropore structures 11 penetrating through a thickness direction of the air deflector 1, and swinging left

and right under the drive of a motor of the air deflector 1; and
a plurality of horizontal swing blade assemblies arranged in parallel up and down along a panel body 3 of the panel structure, wherein each of the plurality of horizontal swing blade assemblies 2 includes a swing rod 21 and one or more horizontal swing blades with a bionic leaf structure, wherein each horizontal swing blade is arranged on the swing rod 21, the swing rod 21 drives the horizontal swing blade to swing up and down under the drive of a drive motor of the swing rod 21, and the horizontal swing blade is provided with one or more second micropore structures 221 penetrating through a thickness direction of the horizontal swing blade.

[0145] Optionally, the horizontal swing blades of any two adjacent horizontal swing blade assemblies are arranged in a staggered manner.

[0146] Optionally, blade sizes of the horizontal swing blades of any two adjacent horizontal swing blade assemblies are different.

[0147] Optionally, a distance between two adjacent horizontal swing blades decreases from a middle position to both sides of the swing rod 21; or, the distance between two adjacent horizontal swing blades increases from the middle position to both sides of the swing rod 21.

[0148] Optionally, a value range of a ratio of a total area of the second micropore structure 221 of the horizontal swing blade to a total area of the horizontal swing blade is [45%, 85%].

[0149] Optionally, the thickness of the horizontal swing blade decreases from the center to the periphery, and a value range of the difference between the maximum thickness and the minimum thickness of the horizontal swing blade is [3mm, 8mm].

[0150] In some optional embodiments, there is provided a panel structure of an air conditioner, including:

an air deflector 1 provided with one or more first micropore structures 11 penetrating through a thickness direction of the air deflector 1, and swinging up and down under the drive of a motor of the air deflector 1; and

a horizontal swing blade assembly including a swing rod 21 and one or more horizontal swing blades, wherein each horizontal swing blade is arranged on the swing rod 21, the swing rod 21 drives the horizontal swing blade to swing up and down under the drive of a drive motor of the swing rod 21, and the horizontal swing blade is provided with one or more second micropore structures 221 penetrating through a thickness direction of the horizontal swing blade.

[0151] Optionally, the horizontal swing blade is configured as a structure including a plurality of parallel sub-blades, and the second micropore structures 221 on any

two adjacent sub-blades are arranged in a staggered manner.

[0152] Optionally, the horizontal swing blade is made of PVC material.

[0153] In some optional embodiments, there is provided a method for controlling an air conditioner, including:

- obtaining an operating mode of the air conditioner;
- and
- controlling operation modes of the air deflector 1 and the horizontal swing blades according to the operating mode.

[0154] In this optional embodiment, different operation modes of the air deflector 1 and the horizontal swing blades can be controlled according to the operating mode of the air conditioner, thereby realizing the control of the different operating modes of the air conditioner, which is flexible and convenient.

[0155] Optionally, the controlling operation modes of the air deflector 1 and the horizontal swing blades according to the operating mode includes:

if the operating mode is a uniform and large air volume operating mode, the air deflector 1 is controlled to swing left and right, and the horizontal swing blades are controlled to swing up and down.

[0156] The air adjusted up and down by the horizontal swing blades is blown out after being adjusted left and right by the air deflector 1, and thus the air conditioner can operate with the uniform and large air volume operating mode.

[0157] If the operating mode is a soft and small air volume operating mode, the air deflector 1 is controlled to swing left and right, and the horizontal swing blades are controlled to close.

[0158] The breeze passing through the second micropore structures 221 of the horizontal swing blade is blown out after being adjusted left and right by the air deflector 1, and thus the air conditioner can operate with the soft and small air volume operating mode.

[0159] If the operating mode is a soft and large air volume operating mode, the air deflector 1 is controlled to close, and the horizontal swing blades are controlled to swing up and down.

[0160] The air adjusted up and down by the horizontal swing blades is blown out through first micropore structures 11 of the air deflector 1, and thus the air conditioner can operate with the soft and large air volume operating mode.

[0161] If the operating mode is a soft breeze operating mode, the air deflector 1 is controlled to close, and the horizontal swing blades are controlled to close.

[0162] The breeze passing through the second micropore structures 221 of the horizontal swing blade is blown out through the first micropore structures 11 of the air deflector 1, and thus the air conditioner can operate with the soft breeze operating mode.

[0163] If the operating mode is a large air volume op-

erating mode, the air deflector 1 is controlled to erect, and the horizontal swing blades are controlled to erect laterally.

[0164] By controlling the horizontal swing blade to erect laterally, and controlling the air deflector 1 to erect, the air blown out from a volute of the air conditioner blows out directly, and thus the air conditioner can operate with the large air volume operating mode.

[0165] In this optional embodiment, the different operation modes of the air deflector 1 and the horizontal swing blades can be controlled according to the operating mode of the air conditioner, thereby realizing the control of the different operating modes of the air conditioner, and meeting the requirements of the users for the different operating modes of the air conditioner.

[0166] In some optional embodiments, there is provided a device for controlling an air conditioner, including:

- a fourth obtaining module configured to obtain an operating mode of the air conditioner; and
- a fourth control module configured to control operation modes of the air deflector 1 and the horizontal swing blades according to the operating mode.

[0167] Optionally, the fourth control module is specifically configured to:

- if the operating mode is a uniform and large air volume operating mode, the air deflector 1 is controlled to swing left and right, and the horizontal swing blades are controlled to swing up and down;
- if the operating mode is a soft and small air volume operating mode, the air deflector 1 is controlled to swing left and right, and the horizontal swing blades are controlled to close;
- if the operating mode is a soft and large air volume operating mode, the air deflector 1 is controlled to close, and the horizontal swing blades are controlled to swing up and down;
- if the operating mode is a soft breeze operating mode, the air deflector 1 is controlled to close, and the horizontal swing blades are controlled to close; and
- if the operating mode is a large air volume operating mode, the air deflector 1 is controlled to erect, and the horizontal swing blades are controlled to erect laterally.

[0168] In some optional embodiments, there is provided a panel structure of an air conditioner, including:

- a panel body 3 provided with one or more first transverse reinforcing ribs along a length direction of the panel body 3 and/or one or more first longitudinal reinforcing ribs along a width direction of the panel body 3;
- an air deflector 1 including a plurality of second air deflectors 13 arranged in parallel left and right along

the panel body 3, wherein each second air deflector 13 swings left and right under the drive by a motor of the air deflector 1, and the second air deflector 13 is provided with one or more first micropore structures 11 penetrating through a thickness direction of the second air deflector 13; and

a horizontal swing blade assembly including a swing rod 21 and one or more horizontal swing blades with a bionic leaf structure, wherein each horizontal swing blade is arranged on the swing rod 21, the swing rod 21 drives the horizontal swing blade to swing up and down under the drive of a drive motor of the swing rod 21, and the horizontal swing blade is provided with one or more second micropore structures 221 penetrating through a thickness direction of the horizontal swing blade.

[0169] It should be noted that when the air deflector 1 swings up and down, the vertical swing blades 22 swing left and right; and when the air deflector 1 swings left and right, the horizontal swing blades swing up and down, and thus the adjustment of the air passing through the air deflector 1 and the swing blades in each direction can be realized. A swing direction of the horizontal swing blades is different from that of the vertical swing blades 22, and the specific structure and implementation of the horizontal swing blades can refer to that of the vertical swing blades 22.

[0170] In some exemplary embodiments, there is further provided an air conditioner, including the panel structure of the air conditioner described above.

[0171] In some exemplary embodiments, there is further provided a non-transitory computer readable storage medium including instructions, for example, a memory including instructions, wherein the instructions can be executed by a processor to perform the aforementioned method. The non-transitory computer readable storage medium described above may be ROM (Read Only Memory), RAM (Random Access Memory), magnetic tape, optical storage device, and the like.

[0172] Those skilled in the art may recognize that the elements and algorithm steps of the examples described in the embodiments disclosed herein may be implemented by electronic hardware, or a combination of computer software and electronic hardware. Whether these functions are implemented by hardware or software depends on the specific application and design constraints of the technical solutions. Those skilled may use different methods to implement the described functions for each specific application, but such implementation should not be considered beyond the scope of the embodiments of the present disclosure. Those skilled may clearly understand that for convenience and conciseness of description, the specific work processes of the above-mentioned systems, devices and units may refer to corresponding processes in the above-mentioned method embodiments and will not be repeated herein.

[0173] In the embodiments disclosed herein, the dis-

closed methods and products (including but not limited to devices, equipment, etc.) may be implemented in other ways. For example, the device embodiments described above are only schematic. For example, the division of the units may be only a logical function division, and there may be other division manners in actual implementation. For example, a plurality of units or components may be combined or integrated into another system, or some features may be ignored or not implemented. In addition, the mutual coupling, direct coupling or communication connection shown or discussed may be indirect coupling or communication connection through some interfaces, devices or units, and may be in electrical, mechanical or other forms. The units described as separate components may or may not be physically separated, and the components displayed as units may or may not be physical units, i.e., may be located in one place or may be distributed to a plurality of network units. Some or all of the units may be selected to implement the embodiments according to actual needs. In addition, each functional unit in the embodiments of the present disclosure may be integrated in one processing unit, or each unit may exist separately physically, or two or more units may be integrated in one unit.

[0174] It should be understood that, the flowcharts and block diagrams in the drawings show the architecture, functions and operations of possible implementations of systems, methods and computer program products according to the embodiments of the present disclosure. In this regard, each block in the flowcharts or block diagrams may represent a module, program segment, or portion of code that includes one or more executable instructions for implementing specified logical functions. In some optional implementations, the functions noted in the blocks may also occur in an order different from that noted in the drawings. For example, two consecutive blocks may actually be executed substantially in parallel, and they may sometimes be executed in a reverse order, depending on the function involved. Each block in the block diagrams and/or flowcharts, and combinations of blocks in the block diagrams and/or flowcharts, may be implemented by special hardware-based systems that perform specified functions or actions, or may be implemented by combinations of special hardware and computer instructions. The present disclosure is not limited to the structures already described above and shown in the accompanying drawings, and various modifications and changes may be made without departing from the scope. The scope of the present disclosure is limited only by the appended claims.

Claims

1. A panel structure of an air conditioner, comprising:
an air deflector provided with one or more first micropore structures penetrating through a

- thickness direction of the air deflector, and swinging up and down under the drive of a motor of the air deflector;
 a vertical swing blade assembly comprising a swing rod and one or more vertical swing blades with a bionic leaf structure, wherein each vertical swing blade is arranged on the swing rod, the swing rod drives the vertical swing blade to swing left and right under the drive of a drive motor of the swing rod, and the vertical swing blade is provided with one or more second micropore structures penetrating through a thickness direction of the vertical swing blade; and a panel body provided with one or more reinforcing ribs.
2. The panel structure according to claim 1, wherein a width of the vertical swing blade decreases from middle to both ends, and a peripheral edge of the vertical swing blade is streamlined.
3. The panel structure according to claim 1, wherein each first micropore structure and/or each second micropore structure is configured as a structure in which cross-sectional areas of a plurality of cross sections increase from middle to both ends.
4. The panel structure according to claim 1, wherein the one or more reinforcing ribs are configured as one or more first transverse reinforcing ribs along a length direction of the panel body and/or one or more first longitudinal reinforcing ribs along a width direction of the panel body.
5. The panel structure according to claim 4, wherein a length of the one or more first transverse reinforcing ribs is equal to that of the panel body, and a length of the one or more first longitudinal reinforcing ribs is equal to a width of the panel body.
6. The panel structure according to claim 4, wherein the air deflector is provided with one or more second transverse reinforcing ribs along a length direction of the air deflector and/or one or more second longitudinal reinforcing ribs along a width direction of the air deflector.
7. The panel structure according to claim 6, wherein when the air deflector is closed, the one or more first transverse reinforcing ribs and the one or more second transverse reinforcing ribs are in the same straight line, and/or the one or more first longitudinal reinforcing ribs and the one or more second longitudinal reinforcing ribs are in the same straight line.
8. The panel structure according to claim 6, wherein each second transverse reinforcing rib and/or each longitudinal reinforcing rib is provided with the first micropore structures.
9. The panel structure according to claim 1, wherein the panel body comprises a first part located around the panel body and a second part located in the middle of the panel body, a density of the first transverse reinforcing ribs in the first part is greater than that of the first transverse reinforcing ribs in the second part, and/or the density of the first longitudinal reinforcing ribs in the first part is greater than that of the first longitudinal reinforcing ribs in the second part.
10. An air conditioner, comprising the panel structure according to any one of claims 1 to 9.

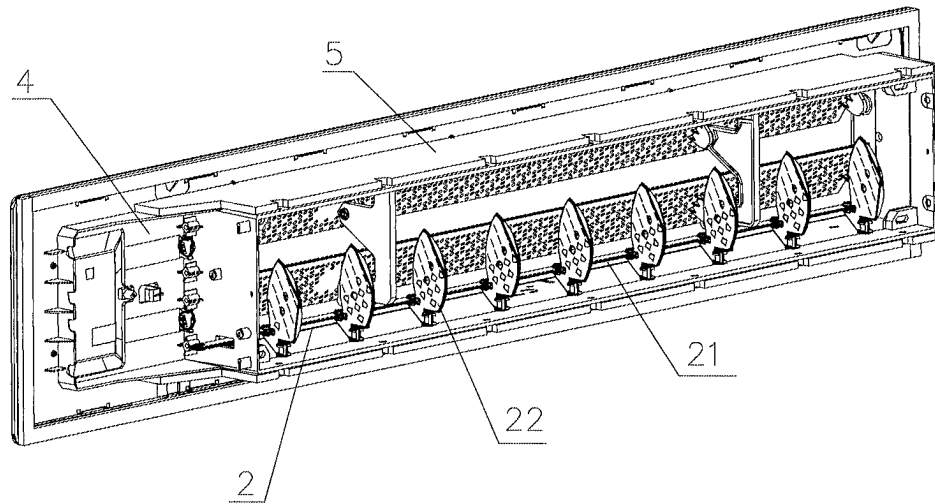

Fig. 1

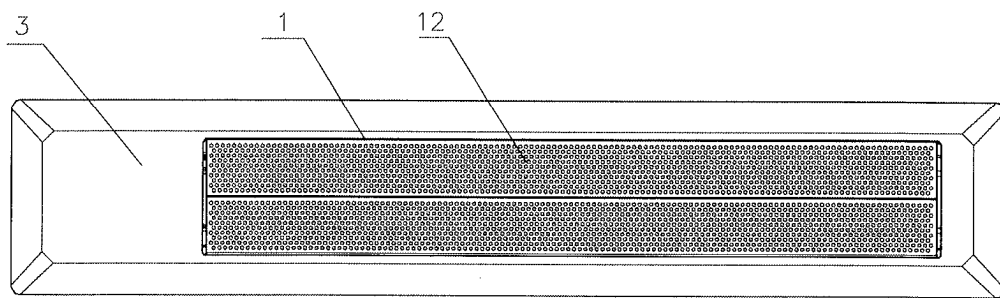

Fig. 2

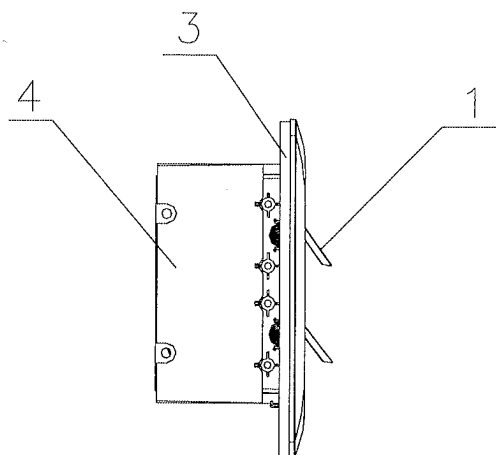

Fig. 3

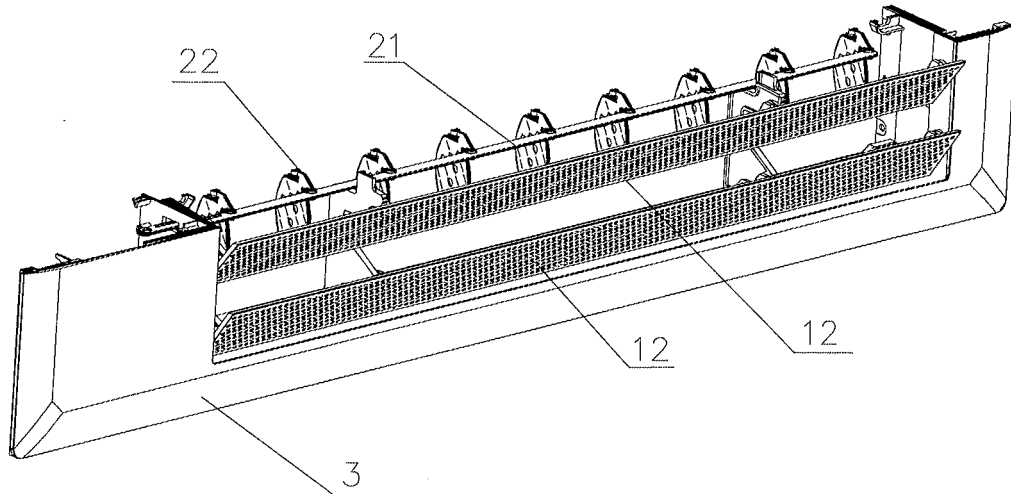

Fig. 4

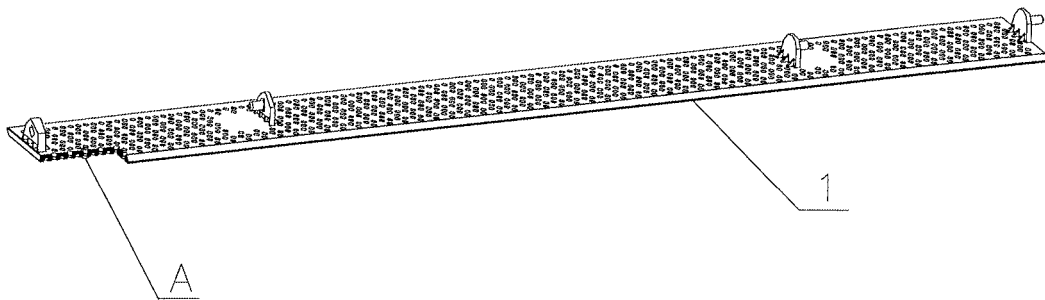

Fig. 5

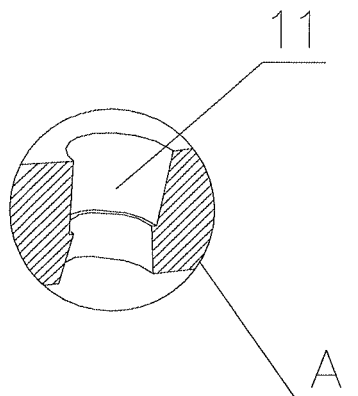

Fig. 6

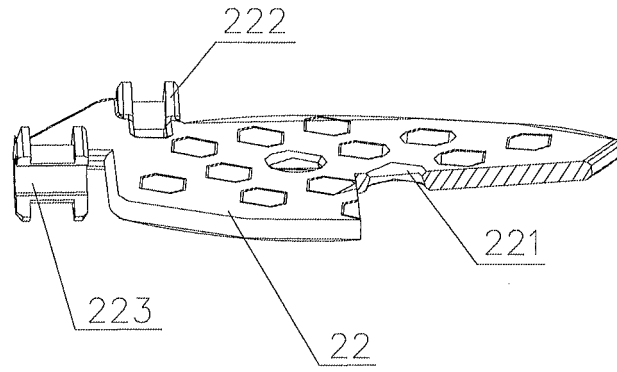

Fig. 7

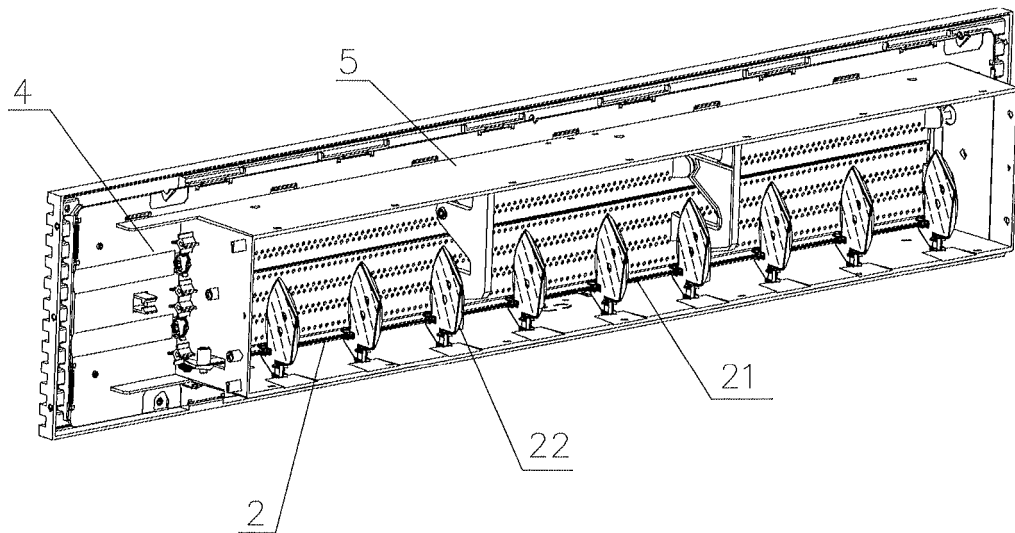

Fig. 8

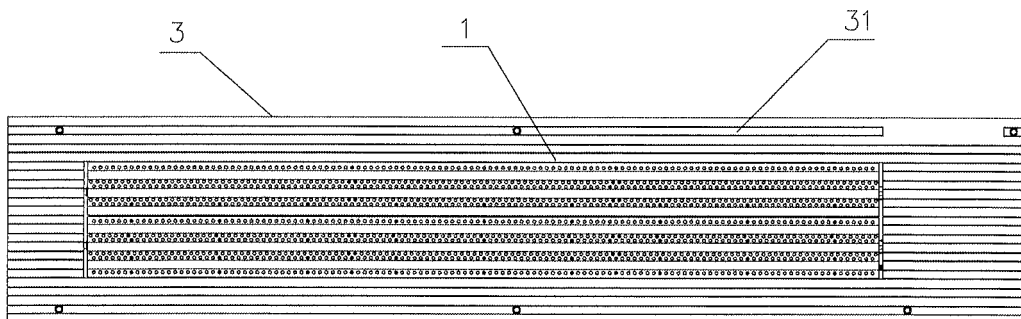

Fig. 9

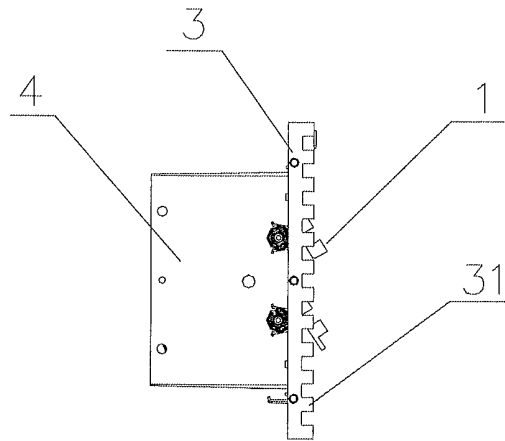

Fig. 10

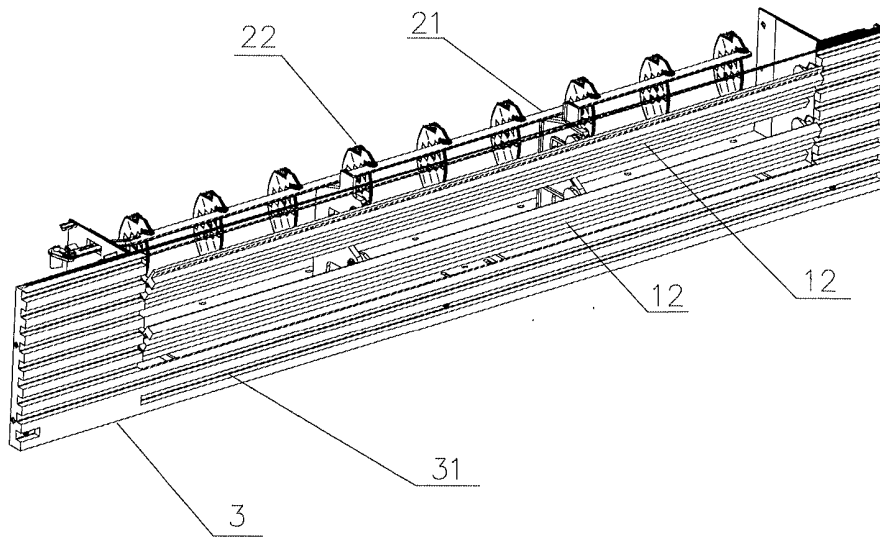

Fig. 11

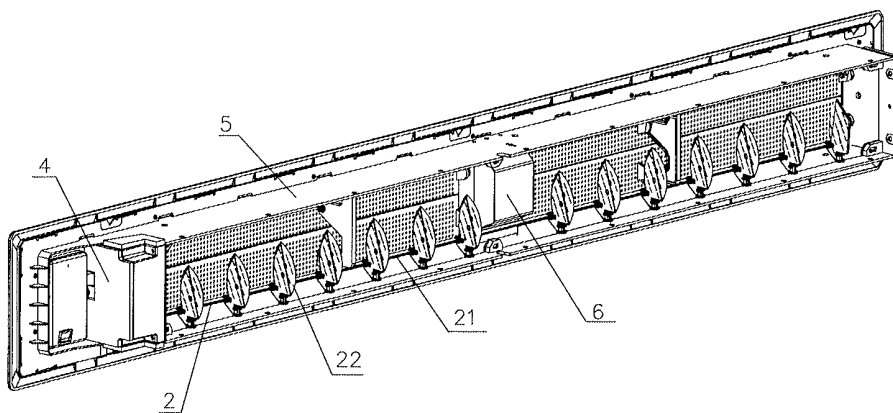

Fig. 12

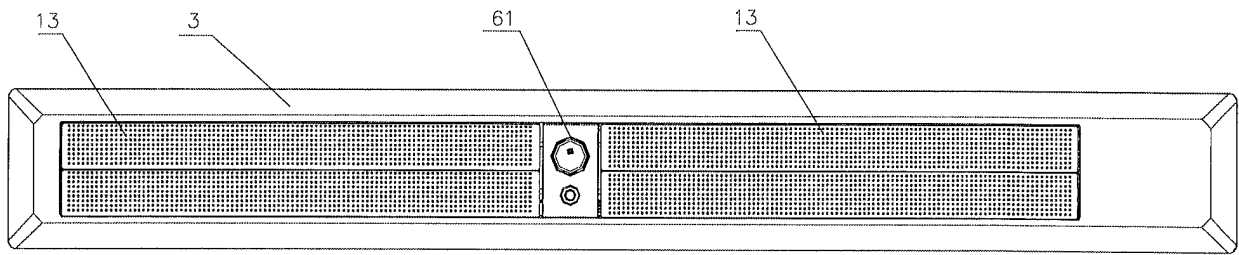

Fig. 13

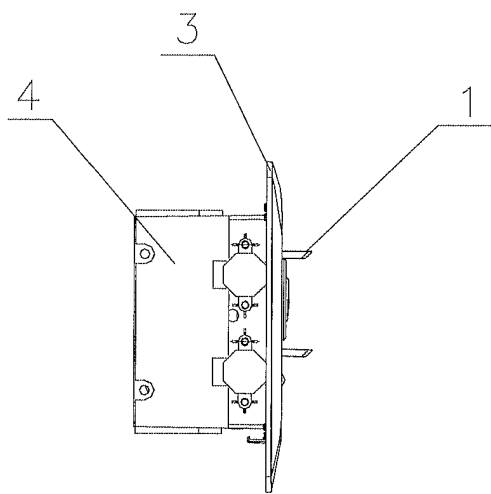

Fig. 14

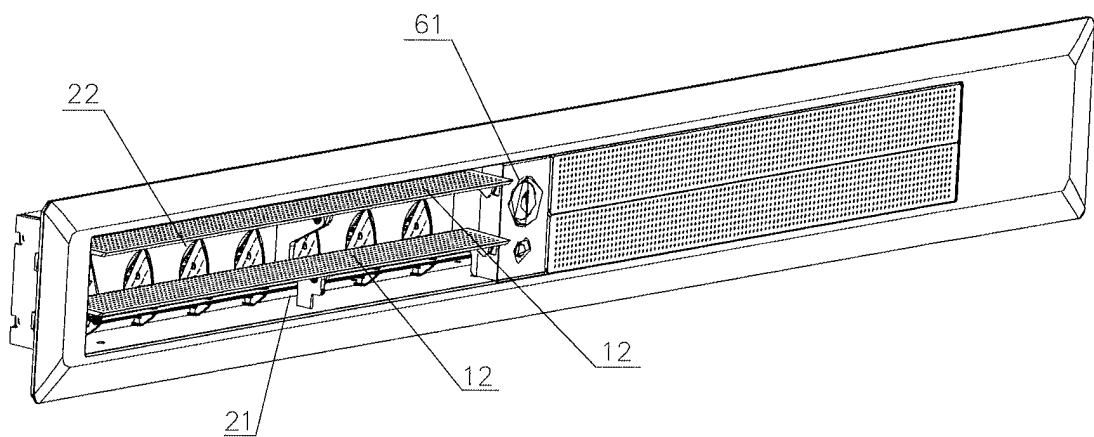

Fig. 15

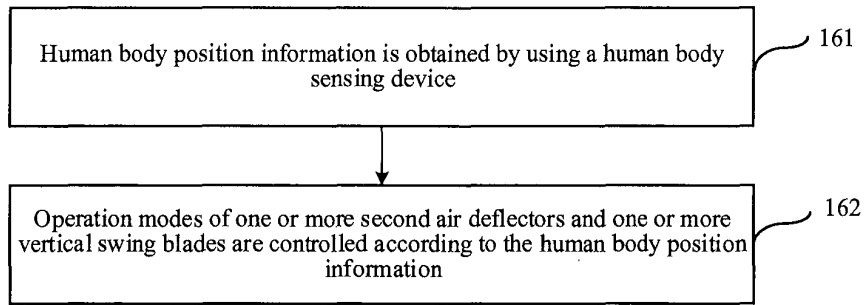

Fig. 16

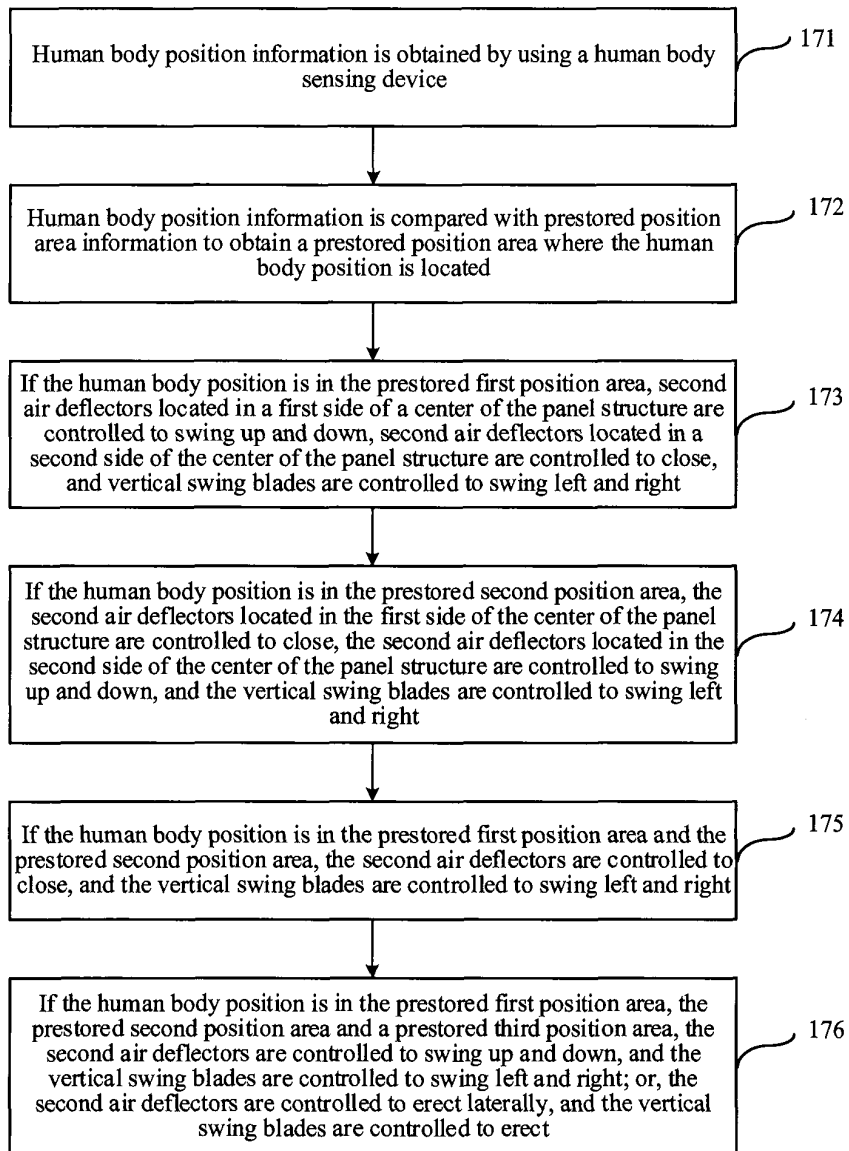

Fig. 17

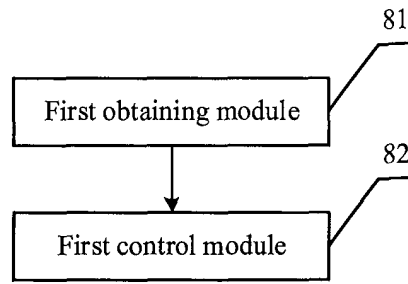

Fig. 18

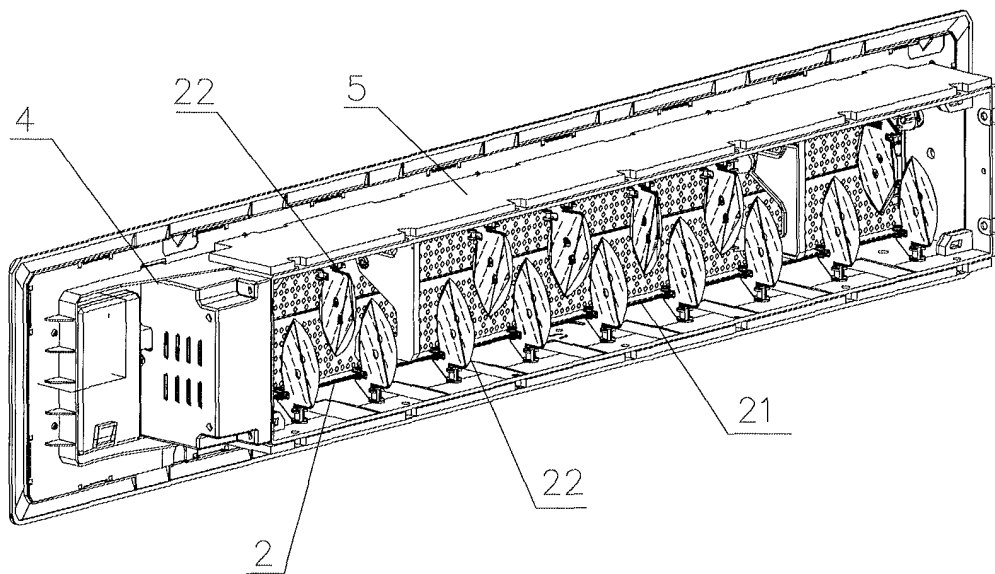

Fig. 19

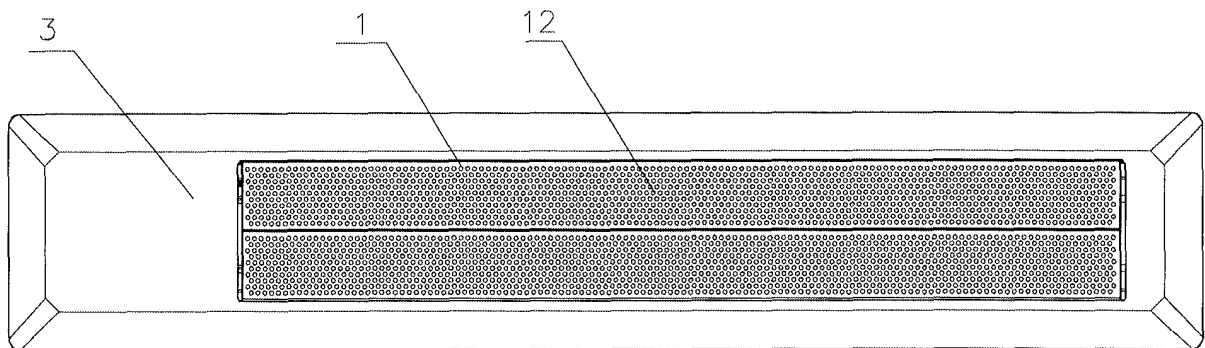

Fig. 20

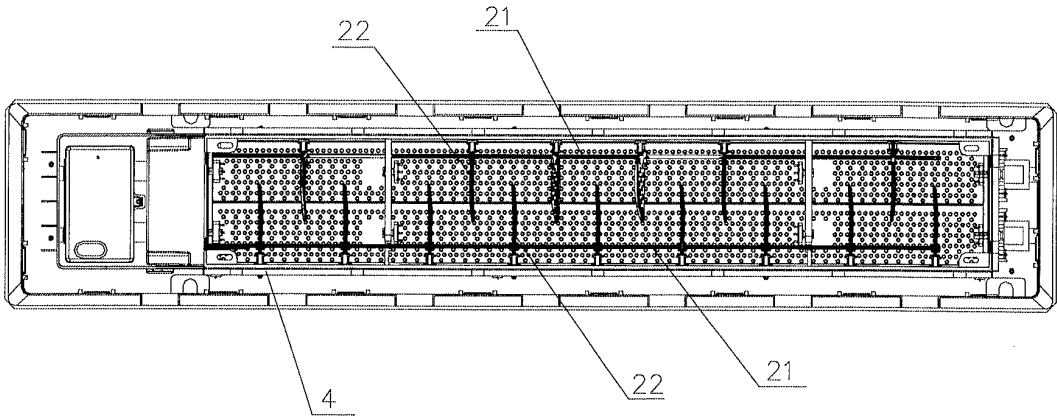

Fig. 21

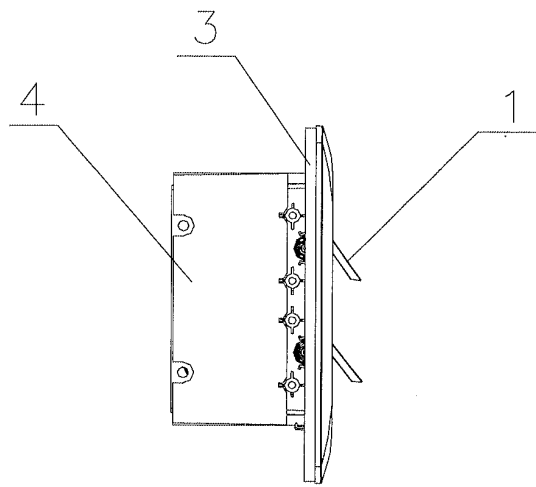

Fig. 22

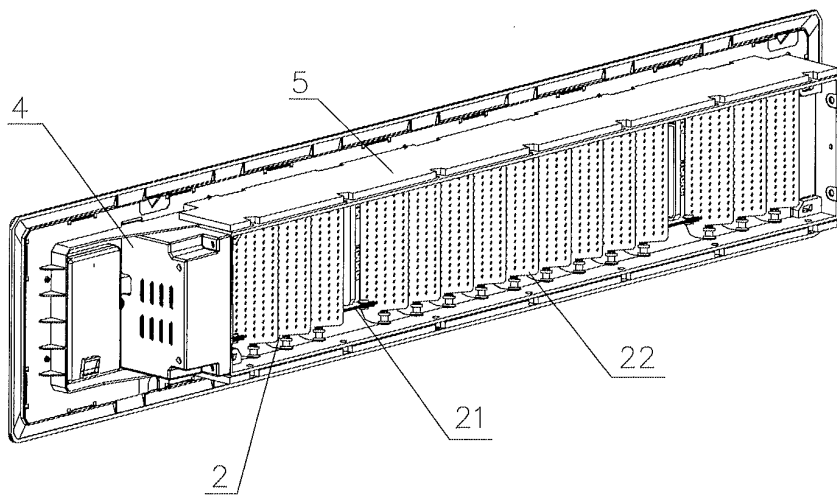

Fig. 23

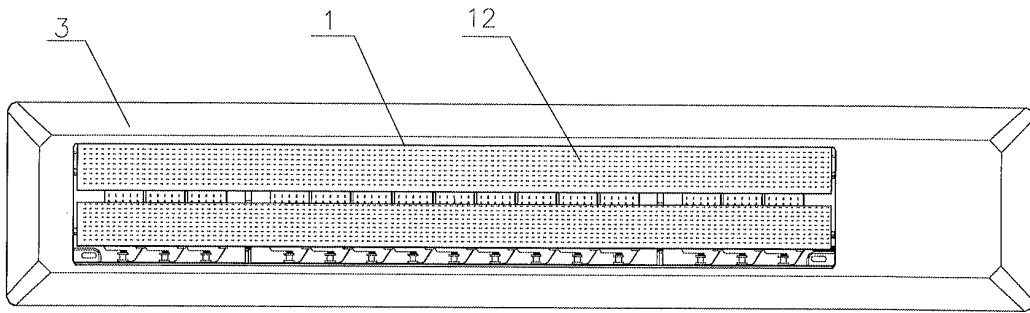

Fig. 24

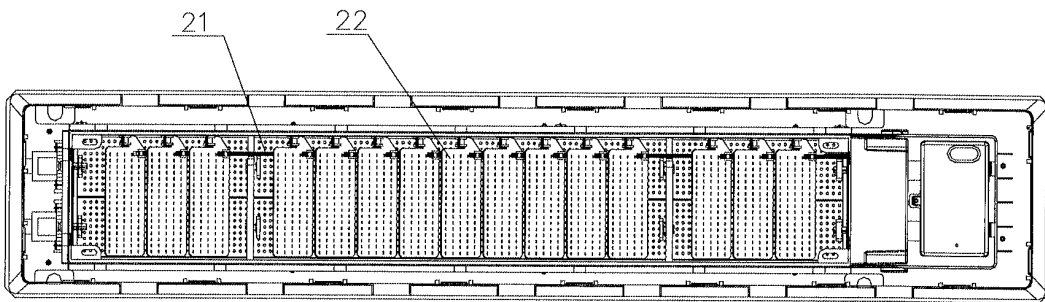

Fig. 25

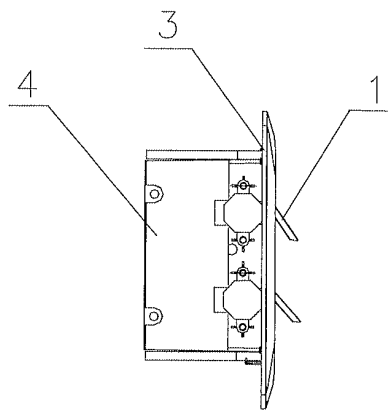

Fig. 26

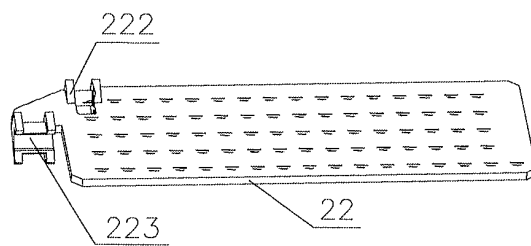

Fig. 27

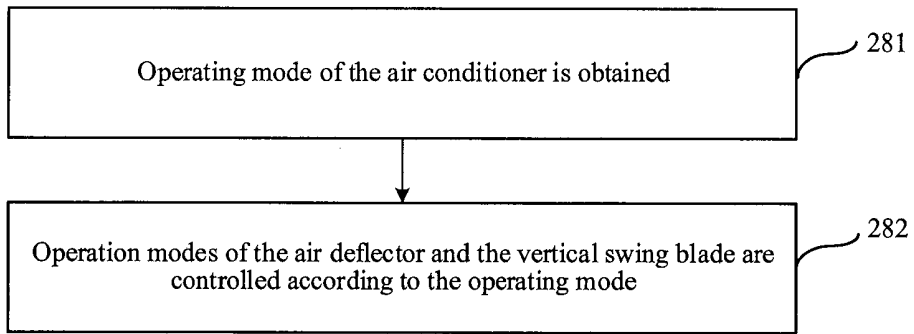

Fig. 28

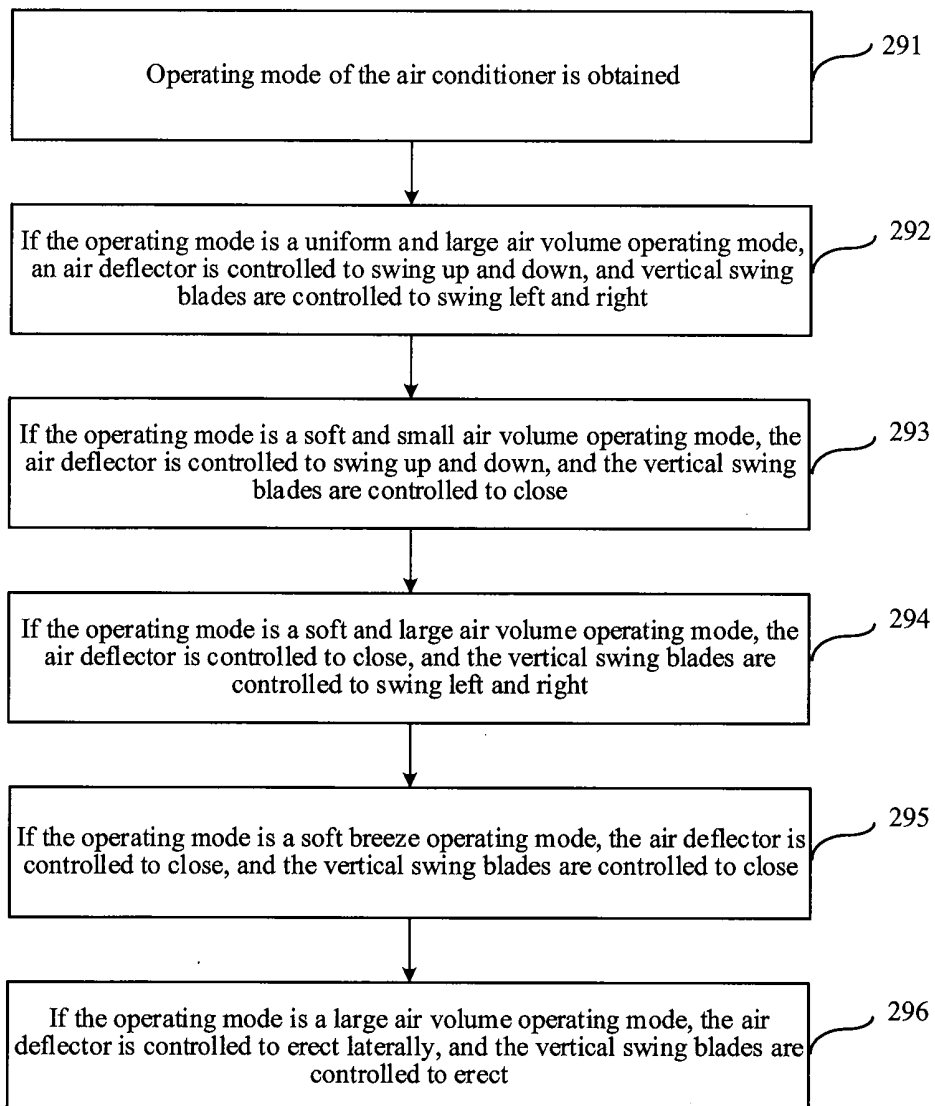

Fig. 29

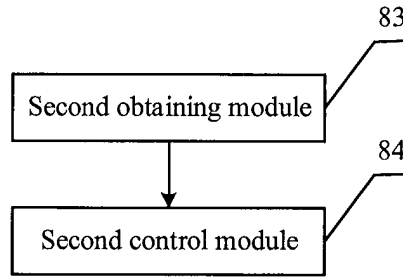

Fig. 30

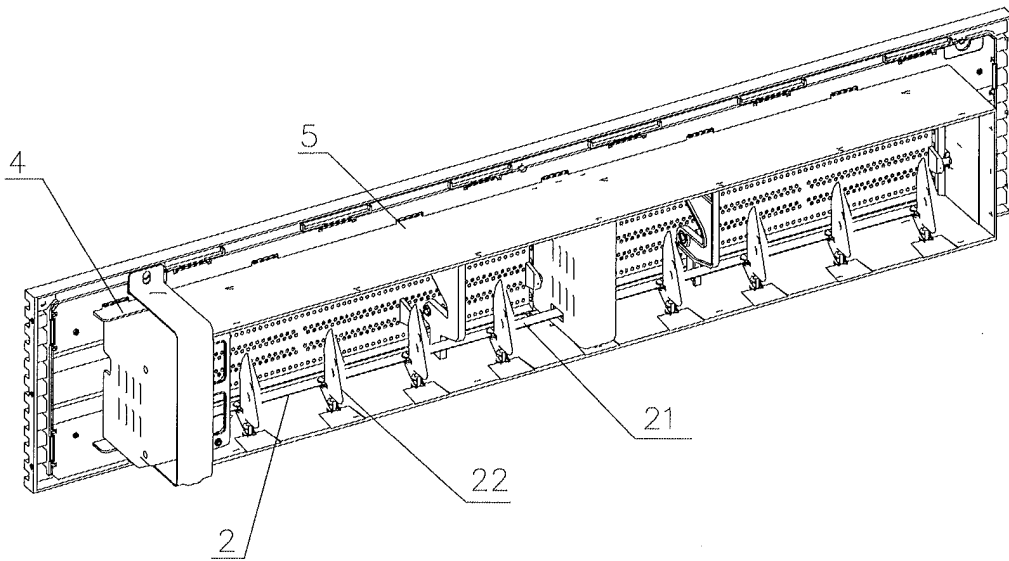

Fig. 31

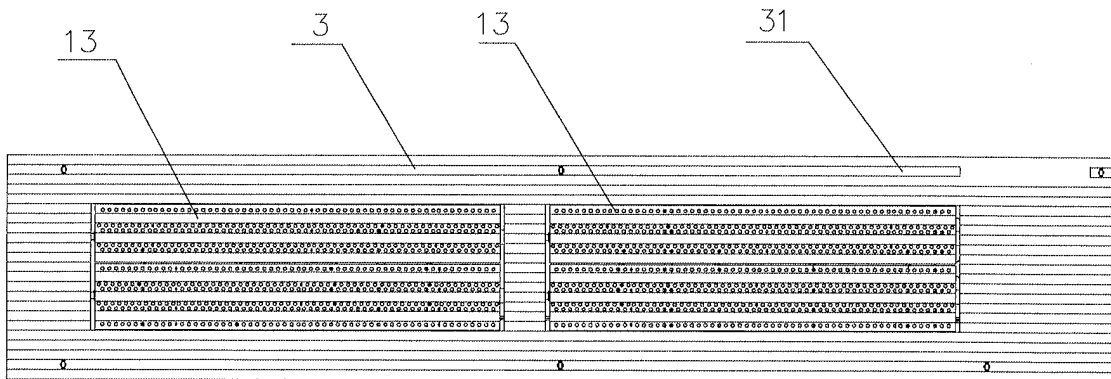

Fig. 32

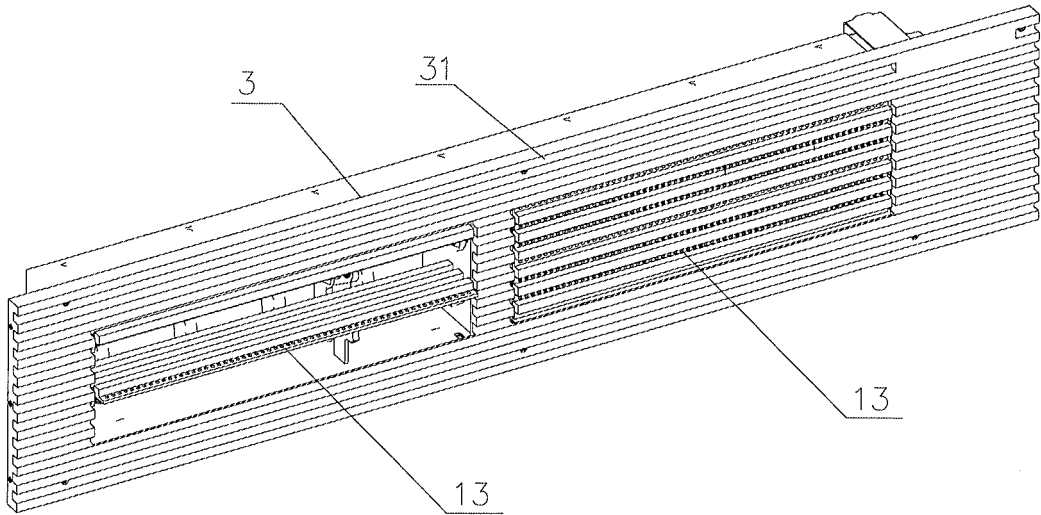

Fig. 33

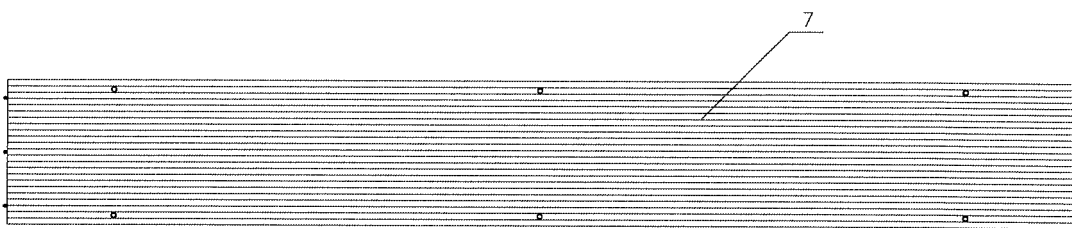

Fig. 34

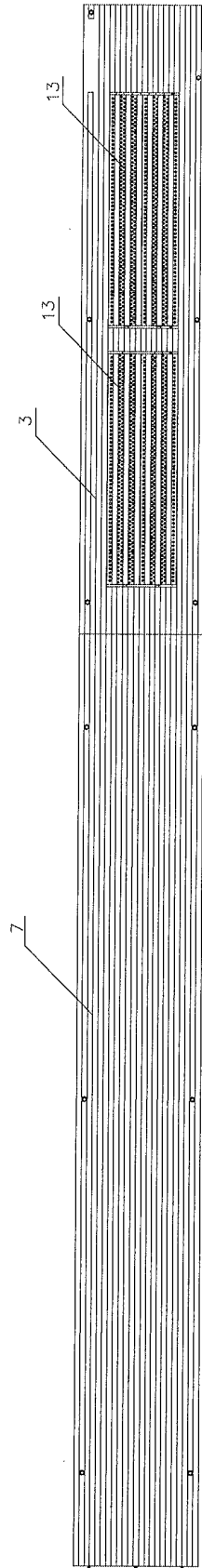

Fig. 35

INTERNATIONAL SEARCH REPORT

International application No.

PCT/CN2018/123019

5	A. CLASSIFICATION OF SUBJECT MATTER F24F 13/14(2006.01)i; F24F 13/20(2006.01)j According to International Patent Classification (IPC) or to both national classification and IPC	
10	B. FIELDS SEARCHED Minimum documentation searched (classification system followed by classification symbols) F24F Documentation searched other than minimum documentation to the extent that such documents are included in the fields searched	
15	Electronic data base consulted during the international search (name of data base and, where practicable, search terms used) DWPI, CNKI, CNABS, SIPOABS, CNTXT, 格力, 美的, 海尔, 大金, 蔡艳芳, 张中晓, 王海胜, 崔丽敏, 空调, 微孔, 通孔, 散流孔, 透气孔, 导风板, 摆叶, 叶片, 加强筋, 加强条, 肋, 凸起, GLDS, LG, air, condition+, hole+, opening+, aperture+, guid+, plate?, vane?, blade?, reforc+, enhance+, strength+, project+, rib?, protrud+, bar	
20	C. DOCUMENTS CONSIDERED TO BE RELEVANT	
25	Category*	Citation of document, with indication, where appropriate, of the relevant passages
30	PX	CN 108692444 A (QINGDAO HAIER AIR CONDITIONER ELECTRIC CO., LTD.) 23 October 2018 (2018-10-23) description, paragraphs [0063]-[0308], and figures 1-35
35	PX	CN 109059236 A (QINGDAO HAIER AIR CONDITIONER ELECTRIC CO., LTD.) 21 December 2018 (2018-12-21) description, paragraphs [0063]-[0305], and figures 1-35
	E	CN 109114755 A (QINGDAO HAIER AIR CONDITIONER ELECTRIC CO., LTD.) 01 January 2019 (2019-01-01) description, paragraphs [0063]-[0323], and figures 1-35
	E	CN 109084458 A (QINGDAO HAIER AIR CONDITIONER ELECTRIC CO., LTD.) 25 December 2018 (2018-12-25) description, paragraphs [0064]-[0308], and figures 1-35
	E	CN 109099570 A (QINGDAO HAIER AIR CONDITIONER ELECTRIC CO., LTD.) 28 December 2018 (2018-12-28) description, paragraphs [0063]-[0310], and figures 1-35
	<input checked="" type="checkbox"/> Further documents are listed in the continuation of Box C. <input checked="" type="checkbox"/> See patent family annex.	
40	* Special categories of cited documents: "A" document defining the general state of the art which is not considered to be of particular relevance "E" earlier application or patent but published on or after the international filing date "L" document which may throw doubts on priority claim(s) or which is cited to establish the publication date of another citation or other special reason (as specified) "O" document referring to an oral disclosure, use, exhibition or other means "P" document published prior to the international filing date but later than the priority date claimed	"T" later document published after the international filing date or priority date and not in conflict with the application but cited to understand the principle or theory underlying the invention "X" document of particular relevance; the claimed invention cannot be considered novel or cannot be considered to involve an inventive step when the document is taken alone "Y" document of particular relevance; the claimed invention cannot be considered to involve an inventive step when the document is combined with one or more other such documents, such combination being obvious to a person skilled in the art "&" document member of the same patent family
45	Date of the actual completion of the international search 09 April 2019	Date of mailing of the international search report 18 April 2019
50	Name and mailing address of the ISA/CN China National Intellectual Property Administration (ISA/ CN) No. 6, Xitucheng Road, Jimenqiao, Haidian District, Beijing 100088 China	Authorized officer
55	Facsimile No. (86-10)62019451	Telephone No.

Form PCT/ISA/210 (second sheet) (January 2015)

INTERNATIONAL SEARCH REPORT

International application No.

PCT/CN2018/123019

5

C. DOCUMENTS CONSIDERED TO BE RELEVANT		
Category*	Citation of document, with indication, where appropriate, of the relevant passages	Relevant to claim No.
E	CN 109084457 A (QINGDAO HAIER AIR CONDITIONER ELECTRIC CO., LTD.) 25 December 2018 (2018-12-25) description, paragraphs [0077]-[0320], and figures 1-35	1-10
Y	CN 108050593 A (WUHU MEIZHI AIR-CONDITIONING EQUIPMENT CO., LTD. ET AL.) 18 May 2018 (2018-05-18) description, paragraphs [0046]-[0083], and figures 1-12	1-10
Y	CN 105823191 A (QINGDAO HAIER AIR CONDITIONER ELECTRIC CO., LTD.) 03 August 2016 (2016-08-03) description, paragraphs [0032]-[0040], and figures 1 and 2	1-10
Y	CN 107401776 A (GUANGDONG MIDEA REFRIGERATION EQUIPMENT CO., LTD.) 28 November 2017 (2017-11-28) description, paragraphs [0075] and [0076], and figures 1-3	3
Y	CN 207501271 U (GUANGDONG MIDEA REFRIGERATION EQUIPMENT CO., LTD. ET AL.) 15 June 2018 (2018-06-15) description, paragraphs [0027]-[0030], and figures 1-4	6-8
A	CN 203443041 U (HAIER GROUP CORPORATION ET AL.) 19 February 2014 (2014-02-19) entire document	1-10
A	CN 106287970 A (WUHU MEIZHI AIR-CONDITIONING EQUIPMENT CO., LTD. ET AL.) 04 January 2017 (2017-01-04) entire document	1-10
A	US 2005186900 A1 (JANESKY LAWRENCE M.) 25 August 2005 (2005-08-25) entire document	1-10

30

35

40

45

50

55

Form PCT/ISA/210 (second sheet) (January 2015)

INTERNATIONAL SEARCH REPORT
Information on patent family members

International application No.

PCT/CN2018/123019

5

10

15

20

25

30

35

40

45

50

55

Patent document cited in search report	Publication date (day/month/year)	Patent family member(s)	Publication date (day/month/year)
CN 108692444 A	23 October 2018	None	
CN 109059236 A	21 December 2018	None	
CN 109114755 A	01 January 2019	None	
CN 109084458 A	25 December 2018	None	
CN 109099570 A	28 December 2018	None	
CN 109084457 A	25 December 2018	None	
CN 108050593 A	18 May 2018	None	
CN 105823191 A	03 August 2016	None	
CN 107401776 A	28 November 2017	CN 108426314 A	21 August 2018
		CN 108731106 A	02 November 2018
		CN 108592366 A	28 September 2018
		CN 108709235 A	26 October 2018
		WO 2019024550 A1	07 February 2019
		CN 207146545 U	27 March 2018
CN 207501271 U	15 June 2018	None	
CN 203443041 U	19 February 2014	None	
CN 106287970 A	04 January 2017	WO 2018040551 A1	08 March 2018
US 2005186900 A1	25 August 2005	US 7556560 B2	07 July 2009

Form PCT/ISA/210 (patent family annex) (January 2015)

REFERENCES CITED IN THE DESCRIPTION

This list of references cited by the applicant is for the reader's convenience only. It does not form part of the European patent document. Even though great care has been taken in compiling the references, errors or omissions cannot be excluded and the EPO disclaims all liability in this regard.

Patent documents cited in the description

- CN 201810804491 [0001]