

(19) World Intellectual Property Organization  
International Bureau



(43) International Publication Date  
20 May 2010 (20.05.2010)

(10) International Publication Number  
**WO 2010/056618 A1**

(51) International Patent Classification:  
*G02F 1/13357* (2006.01)

(21) International Application Number:  
PCT/US2009/063690

(22) International Filing Date:  
9 November 2009 (09.11.2009)

(25) Filing Language: English

(26) Publication Language: English

(30) Priority Data:  
61/114,548 14 November 2008 (14.11.2008) US

(71) Applicant (for all designated States except US): **DOLBY LABORATORIES LICENSING CORPORATION** [US/US]; 100 Potrero Avenue, San Francisco, CA 94103-4813 (US).

(72) Inventor; and

(75) Inventor/Applicant (for US only): **WALLENER, Damir** [CA/CA]; 2985 Virtual Way, Building 3, Ground Floor, Suite 150, Vancouver, British Columbia V5M 4X7 (CA).

(74) Agents: **DOLBY LABORATORIES, INC.** et al.; Intellectual Property Group, 999 Brannan Street, San Francisco, CA 94103-4938 (US).

(81) Designated States (unless otherwise indicated, for every kind of national protection available): AE, AG, AL, AM,

AO, AT, AU, AZ, BA, BB, BG, BH, BR, BW, BY, BZ, CA, CH, CL, CN, CO, CR, CU, CZ, DE, DK, DM, DO, DZ, EC, EE, EG, ES, FI, GB, GD, GE, GH, GM, GT, HN, HR, HU, ID, IL, IN, IS, JP, KE, KG, KM, KN, KP, KR, KZ, LA, LC, LK, LR, LS, LT, LU, LY, MA, MD, ME, MG, MK, MN, MW, MX, MY, MZ, NA, NG, NI, NO, NZ, OM, PE, PG, PH, PL, PT, RO, RS, RU, SC, SD, SE, SG, SK, SL, SM, ST, SV, SY, TJ, TM, TN, TR, TT, TZ, UA, UG, US, UZ, VC, VN, ZA, ZM, ZW.

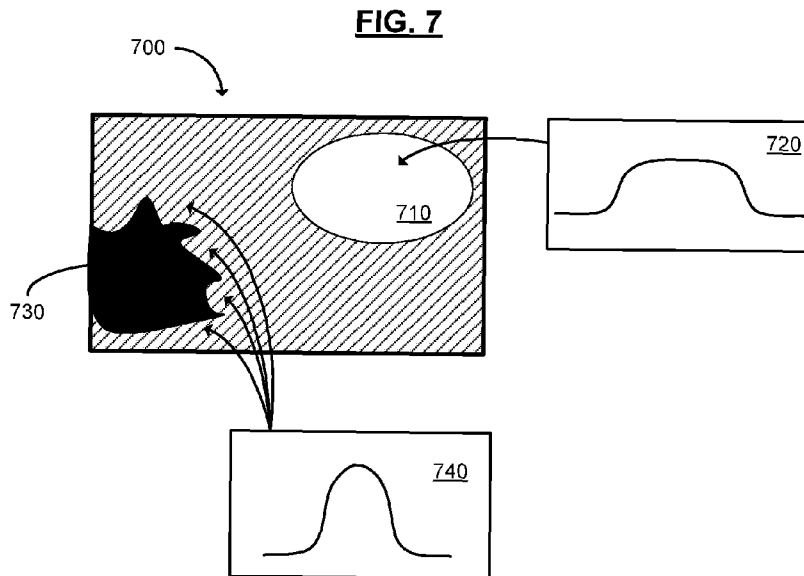
(84) Designated States (unless otherwise indicated, for every kind of regional protection available): ARIPO (BW, GH, GM, KE, LS, MW, MZ, NA, SD, SL, SZ, TZ, UG, ZM, ZW), Eurasian (AM, AZ, BY, KG, KZ, MD, RU, TJ, TM), European (AT, BE, BG, CH, CY, CZ, DE, DK, EE, ES, FI, FR, GB, GR, HR, HU, IE, IS, IT, LT, LU, LV, MC, MK, MT, NL, NO, PL, PT, RO, SE, SI, SK, SM, TR), OAPI (BF, BJ, CF, CG, CI, CM, GA, GN, GQ, GW, ML, MR, NE, SN, TD, TG).

**Declarations under Rule 4.17:**

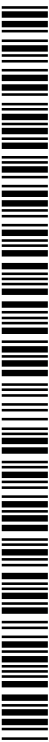
- as to the identity of the inventor (Rule 4.17(i))
- as to applicant's entitlement to apply for and be granted a patent (Rule 4.17(ii))
- as to the applicant's entitlement to claim the priority of the earlier application (Rule 4.17(iii))
- of inventorship (Rule 4.17(iv))

[Continued on next page]

(54) Title: CUSTOM PSFS USING CLUSTERED LIGHT SOURCES



(57) Abstract: Light sources of a backlight are configured to customize the shape of light emitted from the clusters. The clusters are activated as a unit and modulated as to brightness, but of the customized shape. All clusters can have a similar customized PSF, or the customization of each cluster may be varied in real time. Real time changes of a clusters PSF may be based, for example, an image or a region of the image to be displayed using the clusters.



WO 2010/056618 A1

**Published:**

— *with international search report (Art. 21(3))*

## CUSTOM PSFs USING CLUSTERED LIGHT SOURCES

### Cross-Reference to Related Applications

This application claims priority to United States provisional patent application No. 61/114,548 filed November 14, 2008, hereby incorporated by reference in its entirety.

### BACKGROUND OF THE INVENTION

#### Field of Invention

The present invention relates to display devices.

#### Description of Related Art

Existing solutions for LED backlighting use either individually controlled LEDs, or a cluster of LEDs controlled as an individual unit. In each case, each LED is presented with a voltage and currents substantially identical to every other LED.

The diffused light output, or PSF, is essentially pre-determined by the emissive pattern of an individual LED. As shown in Fig. 1, a single LED 100 produces a fixed light emission patten (LED light) 110. The LED light is incident, for example, on optical films 120, resulting in the production of a shaped light output, or PSF 130 (pattern of diffused light). The PSF 130 is essentially constant, but may vary in intensity according to modulation or a brightness level energizing the LED.

A similar result occurs when using light source clusters. Fig. 2 is an example of an LED cluster 200 that results is a PSF 250. Here, the PSF 250 is mainly composed of an aggregate of light from the LED cluster 200. The PSF 250 has a different shape, but again is essentially constant with a varying intensity.

### SUMMARY OF THE INVENTION

The present inventor has realized that a significant obstacle to creating economically-viable individually-modulated LED backlights is the shape of the light being emitted from the LEDs and lighting the back of the LCD panel. The present invention provides a cost-effective way of shaping light emitted by a backlight.

Roughly described, the present invention provides for the creation of PSFs of arbitrary shapes. In one embodiment, the invention comprises an LED cluster comprising an array of LEDs that are energized with a pattern of voltages and/or currents to produce a custom PSF. The array can be aligned on rectangular points, or other arbitrary arrangement, such as triangular or hexagonal. The cluster may be controlled, for example, as a single unit.

In one embodiment, the invention comprises a display, comprising a backlight comprising an array of light sources arranged in clusters, wherein the clusters are configured to emit a light pattern having a custom PSF. The PSF comprises, for example, a customization via the application of at least one of variable spacing between light sources of a cluster, different amounts of energization applied to light sources within a cluster, different types of energization applied to light sources of a cluster, different light source sizes of a cluster. The light sources are, for example, LEDs.

In one embodiment, the custom PSF light pattern may be determined by an energization selected from a group of possible energizations each providing a different custom PSF. The custom PSF light pattern may be determined, for example, by an energization selected from a group of possible energizations each providing a different custom PSF, and a custom PSF light pattern is selected for each cluster based on image data in a region of an image most closely corresponding to the cluster.

In one embodiment, the display further comprises a light modulator disposed so as to be illuminated by the clusters, wherein modulation data of the light modulator comprises artifact reduction to be applied to individual pixels based on at least one custom PSF illuminating the individual pixels. The light clusters, for example, are then energized with light levels roughly equivalent to or approximating a low resolution version of a desired image, and the light modulator further modulates the light emitted from the clusters so that the light approaches the desired image. The further modulation comprises, for example, artifact reduction techniques targeting artifacts created by the use of the custom PSFs.

The above embodiments may include, for example, a processor configured to receive image data and apply variable energization patterns to selected groups of light sources within each cluster to implement a custom PSF selected based on the received image data. The selected custom PSFs are, for example, selected for image regions transitioning to dark comprises a narrow PSF and the selected custom PSF selected for image regions corresponding to bright areas comprises a flat PSF.

The present invention may be embodied as a method, comprising the steps of, receiving image data, evaluating regions of the image data to determine qualities of the image regions, and applying a custom PSF to a cluster of light sources corresponding to each region, wherein the custom light source is best suited to illuminating an area of a light modulator corresponding to the region. In one embodiment, the best suited light sources comprises a narrow PSF for dark transition regions, and a flat PSF for brighter

regions. In another embodiment, the applied custom PSF is selected from a group of custom PSFs.

In various embodiments, the method further comprises the step of determining a modulation for a spatial modulator illuminated by the clusters, wherein the determined modulation comprises artifact reduction techniques selected based on the PSFs of the clusters illuminating the modulator.

Portions of both the device and method may be conveniently implemented in programming on a general purpose computer, or networked computers, and the results may be displayed on an output device connected to any of the general purpose, networked computers, or transmitted to a remote device for output or display. In addition, any components of the present invention represented in a computer program, data sequences, and/or control signals may be embodied as an electronic signal broadcast (or transmitted) at any frequency in any medium including, but not limited to, wireless broadcasts, and transmissions over copper wire(s), fiber optic cable(s), and co-ax cable(s), etc.

#### **BRIEF DESCRIPTION OF THE DRAWINGS**

A more complete appreciation of the invention and many of the attendant advantages thereof will be readily obtained as the same becomes better understood by reference to the following detailed description when considered in connection with the accompanying drawings, wherein:

Fig. 1 is an illustration of a single LED PSF;

Fig. 2 is an illustration of a LED cluster PSF;

Fig. 3 is a schematic of an arrangement of LEDs in a cluster according to an embodiment of the present invention;

Fig. 4 is an illustration of an LED cluster and PSF according to an embodiment of the present invention;

Fig. 5 is a graph of several alternative PSFs that may be utilized or customized further according to various embodiments of the present invention;

Fig. 6 is a schematic drawing of an implementation of a cluster having individual light sources of varying sizes and variable modulation according to an embodiment of the present invention;

Fig. 7 is a drawing of an image on an LCD screen illuminated by different custom PSFs according to an embodiment of the present invention;

Fig. 8 is flow chart of a process according to an embodiment of the present invention; and

Fig. 9 is a system according to an embodiment of the present invention.

### **DESCRIPTION OF THE PREFERRED EMBODIMENTS**

Referring again to the drawings, wherein like reference numerals designate identical or corresponding parts, and more particularly to Fig. 3 thereof, there is illustrated a schematic of an arrangement of LEDs in a cluster 300 according to an embodiment of the present invention. The cluster 300 is an exemplary cluster according to an embodiment of the present invention and comprises a 3x5 array of LEDs (e.g., LED R1,C1 and LED R3,C5 at opposite corners of the array). In other embodiments, specific rows and columns may not be apparent, and the clusters may take on shapes other than row by column arrays.

The LEDs within the cluster may be energized at variable levels. For example, in the exemplary embodiment, LEDs R2,C2/C3/C4/C5 are each shown as being energized at  $V_f = x_2 V$ ,  $I = j_2 \text{ mA}$ ; and the remaining LEDs, including R1,C1 are shown as being energized according to approximately  $V_f = x_1 V$ ,  $I = Y \text{ mA}$ . Here “x1” and “x2” represent different voltages applied to the LEDs. The current driving each LED is represented by “j1” and “j2”. The number of different voltages and currents provided is constrained only by the number of LEDs in the cluster.

Alternatively or in addition, the spacing between any pair or group (e.g., row, column, or subcluster) of LEDs does not have to be constant, allowing for further light shaping possibilities. In the illustrated exemplary array embodiment the LEDs may include, for example, variable spacing of the rows and columns. Variable spacing between LEDs or the indicated variable spacing between rows and/or columns is utilized to customize the PSF ultimately projected from the cluster.

The goal of this flexible arrangement is to increase the light shaping ability of the backlight. The differences in energization level or variable spacing of what are otherwise essentially the same LEDs, causes a different PSF to result. In this case, the interior and middle LEDs have less intensity and would tend to flatten the PSF.

Fig. 4 is an illustration of an LED cluster 400 containing LEDs L1, L2, L3, and L4, and resulting PSF 450 according to an embodiment of the present invention. As illustrated, LEDs L1 and L4 are energized at a higher level ( $V_{f1}$ ,  $I_1$ ) than LEDs L2 and L3 (which are energized, for example, at  $V_{f2}$ ,  $I_2$ , where  $I_2 < I_1$ ). Because of the different energization levels, LEDs L2 and L3 produce less light than LEDs L1 and L4. The result is a diffused PSF with a custom shape.

Fig. 5 is a graph of several alternative PSFs that may be utilized or customized further according to various embodiments of the present invention. The illustrated PSFs may be created, for example, by variable spacing of LEDs in a cluster, variable energization of LEDs within a cluster, variable LED sizing within a cluster, variable LED properties within a cluster, or any other variable of backlights that cause a change or variance in the emitted PSFs.

For example, decreasing the voltage or current to LEDs in the center of the cluster can produce a PSF with a flatter luminance profile across the top, and relatively sharper drop off on the edges. Alternately, the center of the cluster can be driven harder than the edges to create a PSF with higher than usual luminance above the center of the cluster. Adjusting the spacing of LEDs inside the cluster can be used to achieve similar effects by modifying the amount of luminance overlap between LEDs.

All combinations of the above and other variables are envisioned. For example, a custom PSF emitted by an LED cluster wherein LEDs within the cluster have different properties including variable spacing between LEDs, different energizations (e.g., any or all of current, voltage, modulation differences), different native luminosities, different native colors, different sizes, different types of LEDs.

More specifically, each of illustrated and exemplary custom PSFs may be produced as specified in Table 1:

**Table 1**

<u>Name</u>	<u>Construction</u>	<u>1<sup>st</sup> Alternate Construction</u>	<u>Potential Use</u>
Normal 500	Evenly spaced array of light sources with similar properties	Unevenly spaced light sources of different intensities	Average intensity areas
Lattice 510	Bright cluster outline	Central region of cluster having greater spacing between light sources	Daylight scenes
Variable 1 520	Decreasing intensity moving	Less light sources and even greater spacing	Brightest areas

	inward, without decreasing peak PSF intensity	between light sources	
Variable 2 530	Bright central region	More LEDs and/or less space between LEDs in central region of cluster	Bright to dark transitions (esp near the dark areas)

The variable 1 and variable 2 examples illustrate yet another feature of the invention where one or more relatively brighter (or relatively dimmer) light sources in a cluster can change position. Such embodiments may be implemented through electronic switching that identifies the light source(s) of a cluster that is intended to be relatively brighter or dimmer. In the case of variable 2 PSF 530, a selected relatively brighter light source is “shifted” left (from R2C3 to R2C2 of cluster 535 causing a peak of the PSF 530 to shift left (shifted PSF 532). The result is a peak that may be electronically shifted.

Shifting or changing properties of other PSFs can take the form of further shifting or re-shaping of the PSFs on-the-fly (e.g., usable in changing PSFs during viewing of images displayed using the PSFs). In addition to the flexibility afforded by being able to shift the peaks of a PSF, such shifting may also be used to more closely target transition areas that could benefit from having a sharp peaked PSF by moving the peak more precisely into position at a transition, or following a moving transition between frames of a video.

Other alternate constructions may utilize, for example, smaller light sources where constructions call for greater spacing between light sources and/or decreased intensity light sources. Fig. 5 also indicates exemplary physical construction of the 535clusters (e.g., variable 2 having 2 higher luminance light sources surrounded by a border of relatively lower luminance light sources. And again, any number of combinations of spacing, driven intensities, or light source sizes may be utilized to create the same or similar effects.

Fig. 6 is a schematic drawing of an implementation of a cluster 600 having individual light sources of varying sizes and variable modulation according to an embodiment of the present invention. The light sources are approximately evenly spaced, but are of different sizes and luminosities. In this example a central light source 610 is a relatively large sized LED and the surrounding, relatively smaller light sources are



relatively smaller LEDs. In addition, the clusters, which are preferably controlled as a unit, may optionally include a modulation device 650, that varies a modulation of the cluster so it produces PSFs of varying overall intensity.

In this example, the modulation device 650 provides a modulated power source for driving the LEDs. Different types of modulation may be utilized, and, in this example, modulation device 650 is a Pulse Width Modulation (PWM) device. In one embodiment, rather than being controlled strictly as a unit, multiple modulation devices may be utilized. For example, by provision of a second modulation device (not shown), one modulation device can be configured to energize the smaller LEDs as a group and the other modulation device can be configured to energize the larger sized central light source 610. Like the differences in light source size, spacing, luminosity, etc, differences in modulation between the various light sources in a cluster can affect the PSF of the cluster in a manner to produce the desired PSF.

In one embodiment, a display according to the present invention is produced by providing a series of clusters similarly customized according to one or more embodiments of the present invention. The similarly customized clusters are arranged, for example, as a backlight in a dual modulation High Dynamic Range display. The customization of the PSFs is, for example, selected as a PSF that is best suited for all regions of an entire image to be displayed. The best suited PSF is determined, for example, by averaging areas or regions of an image to be displayed, and selecting the PSF that meets a set of predetermined requirements for each area or region.

Alternatively, a backlight in a dual modulation display may be configured with a series of clusters, each being customizable on-the-fly. In one embodiment, all of the clusters are customized on-the-fly. On-the-fly customization is performed, for example, by varying by one or more real-time variable PSF customization properties, such as, for example, varying a luminosity of predetermined sets of LEDs within a cluster. Such real-time customizations may be performed on straight row by-column arrays of LED clusters, or clusters with, for example, varied "fixed" customizations (e.g., LED spacing, sizing, or other not normally adjustable qualities). In one embodiment, each cluster includes a programmable switch that varies the PSFs in varying degrees from, for example, a sharp contrasting PSF to a low flat-top PSF. The customized PSF is then energized as a unit for a desired brightness or luminosity of the entire PSF.

Fig. 7 is a drawing of an image on an LCD screen 700 illuminated by different custom PSFs according to an embodiment of the present invention. The displayed image

includes a bright area 710 and a dark area 730 separated by moderately bright or transitional areas. As shown, a “flattened” PSF 720 (e.g., similar to 510/520) is utilized in clusters directly illuminating the bright area 710. The transitional areas, particularly those close to the dark area 730 are illuminated with backlight clusters exhibiting a more “peaked” PSF 740 (e.g., similar to Variable 2 530 described above). In this manner, each portion of an image being reproduced may use a backlight cluster that is particularly advantageous to the image qualities of the portion.

Fig. 8 is flow chart of a process 800 according to an embodiment of the present invention. The process 800 implements an on-the-fly customized PSF based on a received image. At step 810 an image is received. The image is for example, a portion of an HDTV over-the-air broadcast, video/image data received from cable or satellite, video/image content from a DVD/Blue Ray player, i-Pod, Hard Disk Drive (HDD), memory stick or other storage device, and/or video/images received from a cell phone, network, or high speed internet or intranet. The video/image data may be coupled with, for example, audio data such as Dolby Digital® or other audio formats for use in the simultaneous presentation of audio media.

At step 820, the image data is sectioned and evaluated. The sections of the image, for example, roughly correspond to areas or regions of an image mainly illuminated by each cluster. The evaluation comprises, for example, an averaging of luminosities, colors, or other properties of the image within each section. The evaluation may include, for example, a transition evaluation to identify transitional areas between light or moderate and dark sections of the image.

Based on the evaluation a custom PSF is selected, and, at step 830 the backlight clusters are customized to produce the selected PSFs. At step 840, 2<sup>nd</sup> modulation values are calculated (e.g., LCD modulation values). The LCD modulation values may be calculated in anyway that results in the desired image being displayed when backlit by the clusters with customized PSFs, including, for example, modulating the LCD with differences between a pattern of light emitted by the backlight clusters and the desired image. In one embodiment, the LCD is modulated with data of the desired image.

However, depending on the PSFs selected, more or less artifacts may be produced. Therefore, based on the PSF patterns selected and their implementation, the present invention includes a customization of artifact reduction processing which results in optimized values used to control the LCD pixels for pixels illuminated by the selected PSFs. And, for example, since the LCD pixels on one part of the display are potentially

illuminated by a backlight cluster of a different PSF compared to LCD pixels on a different part of the display, various sets of pixels values are produced through processing that utilizes different sets of artifact reduction techniques. Such artifact reduction techniques may be selected, for example, from those described in *Harrison et al.*, U.S. Provisional Patent Application Serial No. 61/020,104, entitled “*Mitigation Of LCD Flare*,” filed 1/9/2008.

Each such technique would be tested against each potential type of PSF and the best technique or set of techniques are memorialized in a database or table from which they are selected. Alternatively, the database is maintained within the programming or code of a device operating according to the present invention.

Fig. 9 is a system according to an embodiment of the present invention. A processor 910 receives image data from any of a number of sources. The processor includes, for example, a memory 915 or other computer readable storage that provides instructions that, when loaded into a CPU or other computing mechanism of the processor, cause the processor to perform the steps of the processes described herein. In some embodiments, Memory 915 also includes, for example, storage for a PSF database and is utilized by programming that instructs processor 910.

The image data is processed (including any processing necessary to extract the image data from its broadcast or transmitted formats (e.g., ATSC, PAL, MPEG, MPEG-4, AVC, and other formats)). The processing also includes image sectioning and evaluation, selection of PSFs as described above, and the production of control signals 920 for energizing the backlight in a manner to produce the selected custom PSFs. The control signals 920 are transmitted to a backlight 925.

Modulation signals 930 for controlling LCD pixels, and including any selected artifact reduction techniques as described above are also produced based in part on the selected PSFs and are transmitted to an LCD 935. The combination of custom PSFs produced by the backlight and LCD modulation provides an image on an HDTV or monitor device 940 and viewed by a viewer 950.

Although LEDs and light sources are used somewhat interchangeably herein, the present invention has been described herein with reference to LEDs for use in creating backlight clusters. However, it should be understood that other types of light source may be substituted therewith. In addition, the present invention describes dual modulation mainly using an LCD panel as a 2<sup>nd</sup> modulator, but it should be understood that other types of modulators (e.g., spatial light modulators) may be substituted therewith. Further,

other types of displays or projection systems can be modified or fitted with the techniques and processes described herein which will be apparent to the ordinarily skilled artisan upon review of the present disclosure.

In describing preferred embodiments of the present invention illustrated in the drawings, specific terminology is employed for the sake of clarity. However, the present invention is not intended to be limited to the specific terminology so selected, and it is to be understood that each specific element includes all technical equivalents (including legal doctrine related equivalents and what one of ordinary skill in the art would understand as an equivalent). For example, when describing a cluster, any other equivalent device, such as a string of lights in parallel or series, light sources from phosphors, electrical sources, nanotube based light emission devices, or lights of other origins, or other devices having an equivalent function or capability, whether or not listed herein, may be substituted therewith. Furthermore, the inventors recognize that newly developed technologies not now known may also be substituted for the described parts and still not depart from the scope of the present invention. All other described items, including, but not limited to the parts and processes of the present invention, should also be considered in light of any and all available equivalents.

Portions of the present invention may be conveniently implemented using a conventional general purpose or a specialized digital computer or microprocessor programmed according to the teachings of the present disclosure, as will be apparent to those skilled in the computer art.

Appropriate software coding can readily be prepared by skilled programmers based on the teachings of the present disclosure, as will be apparent to those skilled in the software art. The invention may also be implemented by the preparation of application specific integrated circuits or by interconnecting an appropriate network of conventional component circuits, as will be readily apparent to those skilled in the art based on the present disclosure.

The present invention includes a computer program product which is a storage medium (media) having instructions stored thereon/in which can be used to control, or cause, a computer to perform any of the processes of the present invention. The storage medium can include, but is not limited to, any type of disk including floppy disks, mini disks (MD's), optical discs, DVD, HD-DVD, Blue-ray, CD-ROMS, CD or DVD RW+/-, micro-drive, and magneto-optical disks, ROMs, RAMs, EPROMs, EEPROMs, DRAMs, VRAMs, flash memory devices (including flash cards, memory sticks), magnetic or

optical cards, SIM cards, MEMS, nanosystems (including molecular memory ICs), RAID devices, remote data storage/archive/warehousing, or any type of media or device suitable for storing instructions and/or data.

Stored on any one of the computer readable medium (media), the present invention includes software for controlling both the hardware of the general purpose/specialized computer or microprocessor, and for enabling the computer or microprocessor to interact with a human user or other mechanism utilizing the results of the present invention. Such software may include, but is not limited to, device drivers, operating systems, and user applications. Ultimately, such computer readable media further includes software for performing the present invention, as described above.

Included in the programming (software) of the general/specialized computer or microprocessor are software modules for implementing the teachings of the present invention, including, but not limited to, receiving image data, unpacking image data, sectioning image data, selecting custom PSFs, preparing modulation signals, including LCD modulation signals with artifact reduction applied, selecting artifact reduction based on selected customized PSFs of backlight clusters, and the display, storage, or communication of results according to the processes of the present invention.

The present invention may suitably comprise, consist of, or consist essentially of, any of element (the various parts or features of the invention) and their equivalents. Further, the present invention illustratively disclosed herein may be practiced in the absence of any element, whether or not specifically disclosed herein. Obviously, numerous modifications and variations of the present invention are possible in light of the above teachings. It is therefore to be understood that within the scope of claims to be included in a subsequently filed utility patent application, the invention may be practiced otherwise than as specifically described herein.

**WHAT IS CLAIMED:**

1. A display, comprising a backlight comprising an array of light sources arranged in clusters, wherein the clusters are configured to emit a light pattern having a custom PSF.
2. The display according to Claim 1, wherein the PSF is customized via the application of at least one of variable spacing between light sources of a cluster, different amounts of energization applied to light sources within a cluster, different types of energization applied to light sources of a cluster, different light source sizes of a cluster.
3. The display according to Claim 2, wherein the light sources comprise LEDs.
4. The display according to Claim 1, wherein the custom PSF light pattern is determined by an energization selected from a group of possible energizations each providing a different custom PSF.
5. The display according to Claim 1, wherein the custom PSF light pattern is determined by an energization selected from a group of possible energizations each providing a different custom PSF, and a custom PSF light pattern is selected for each cluster based on image data in a region of an image most closely corresponding to the cluster.
6. The display according to Claim 1, further comprising a light modulator disposed so as to be illuminated by the clusters, wherein modulation data of the light modulator comprises artifact reduction to be applied to individual pixels based on at least one custom PSF illuminating the individual pixels.
7. The display according to Claim 1, further comprising a processor configured to receive image data and apply variable energization patterns to selected groups of light sources within each cluster to implement a custom PSF selected based on the received image data.
8. The display according to Claim 7, wherein the selected custom PSF selected for image regions transitioning to dark comprises a narrow PSF and the selected custom PSF selected for image regions corresponding to bright areas comprises a flat PSF.
9. A method, comprising the steps of:
  - receiving image data;
  - evaluating regions of the image data to determine qualities of the image regions;

applying a custom PSF to a cluster of light sources corresponding to each region, wherein the custom light source is best suited to illuminating an area of a light modulator corresponding to the region.

10. The method according to Claim 9, wherein the best suited light sources comprises a narrow PSF for dark transition regions, and a flat PSF for brighter regions.

11. The method according to Claim 9, wherein the applied custom PSF is selected from a group of custom PSFs.

12. The method according to Claim 9, further comprising the step of determining a modulation for a spatial modulator illuminated by the clusters, wherein the determined modulation comprises artifact reduction techniques selected based on the PSFs of the clusters illuminating the modulator.

13. The method according to Claim 9,  
said method is embodied in a set of computer instructions stored on a computer readable media;

said computer instructions, when loaded into a computer, cause the computer to perform the steps of said method.

14. The method according to Claim 13, wherein said computer instruction are compiled computer instructions stored as an executable program on said computer readable media.

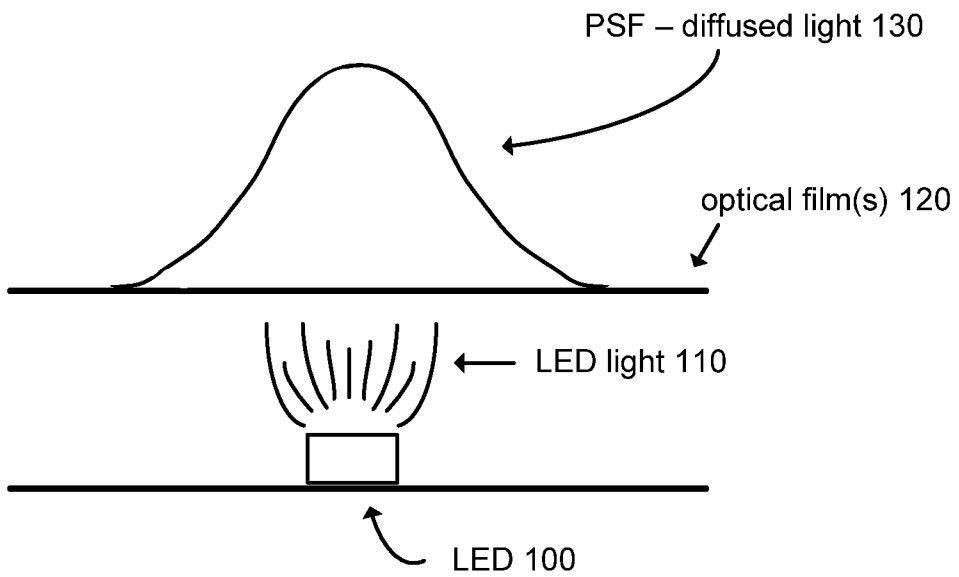
15. The method according to Claim 9, wherein said method is embodied in a set of computer readable instructions stored in an electronic signal comprising electromagnetic waves having variations in physical properties and thereby exhibiting a modulation configured to carry and communicate the instructions.

16. The method according to Claim 12,  
said method is embodied in a set of computer instructions stored on a computer readable media;

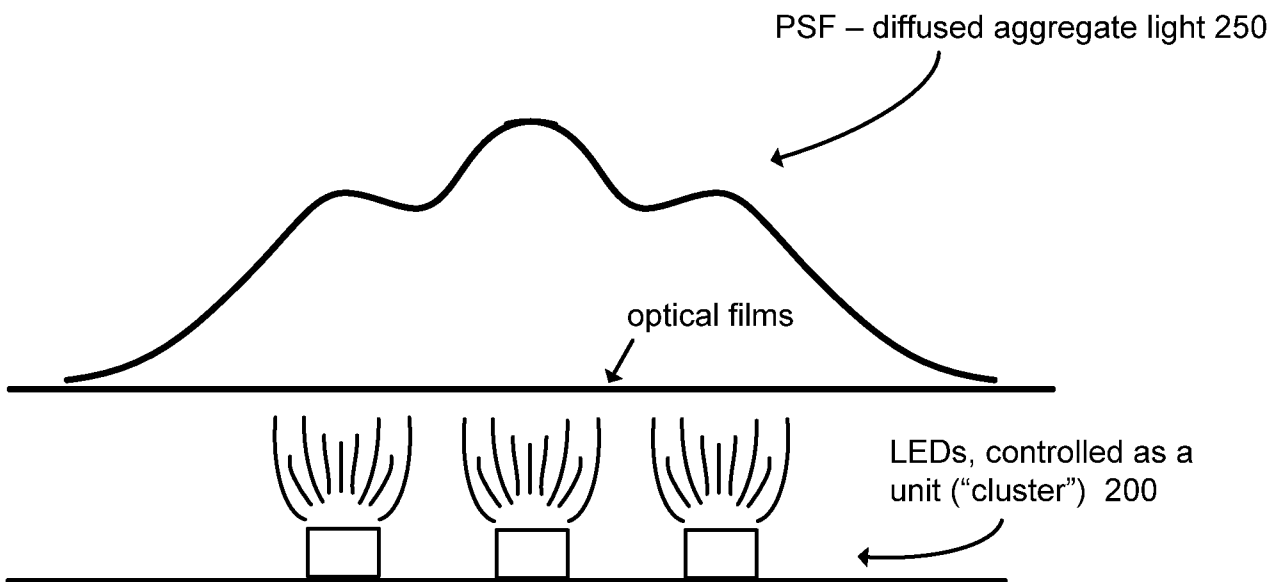
said computer instructions, when loaded into a computer, cause the computer to perform the steps of said method.

17. The method according to Claim 16, wherein said computer instruction are compiled computer instructions stored as an executable program on said computer readable media.

**FIG. 1**

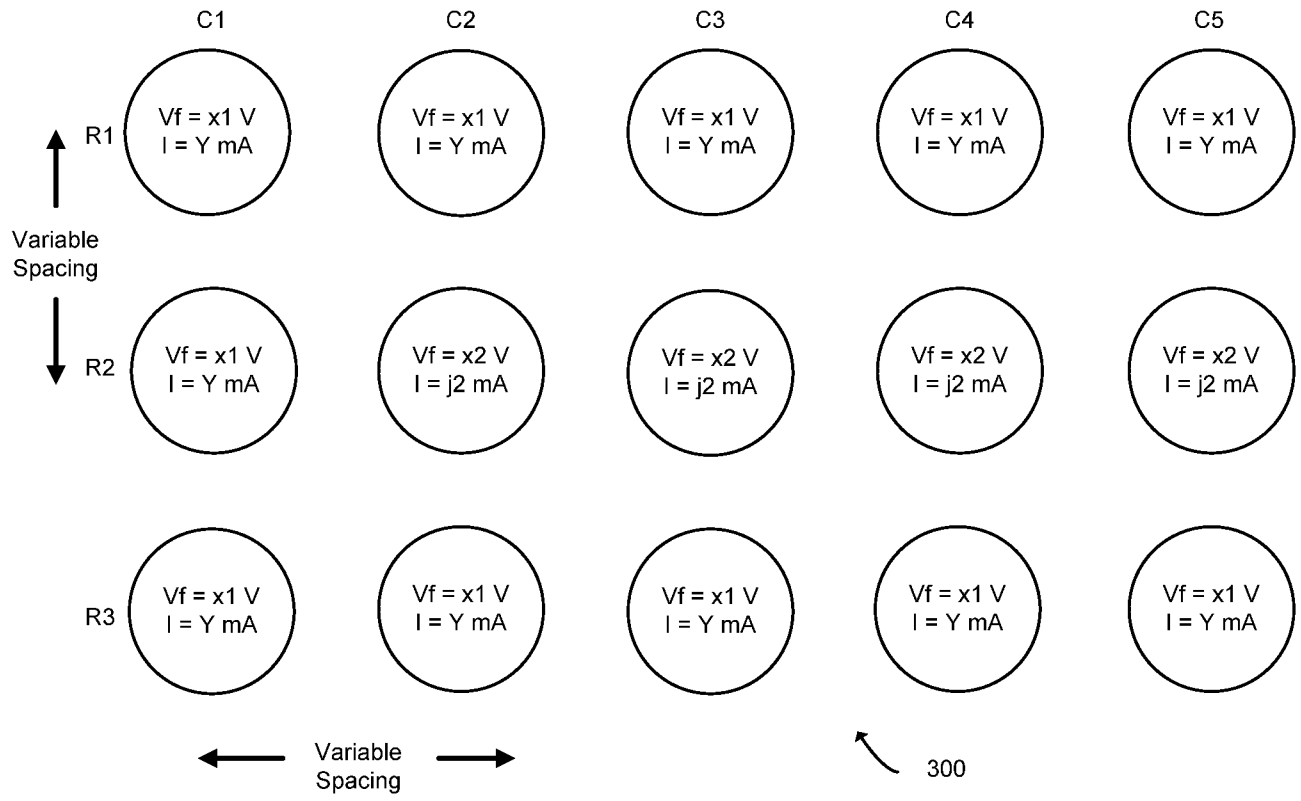


**FIG. 2**

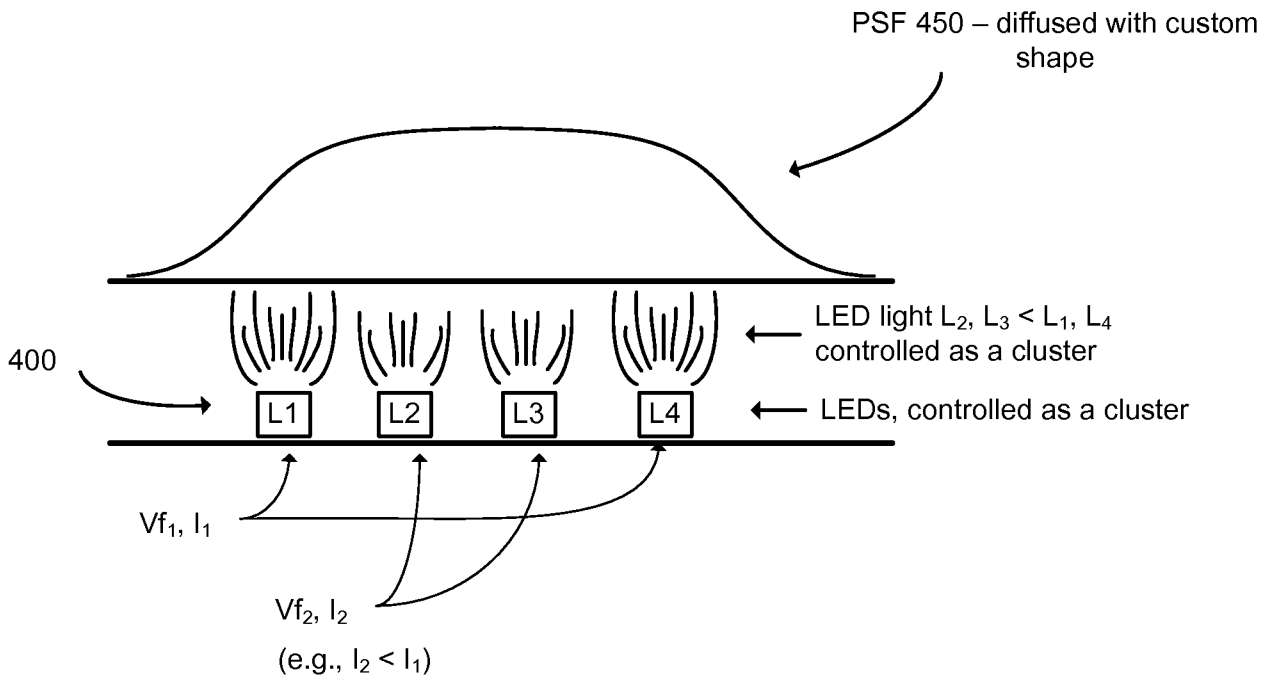




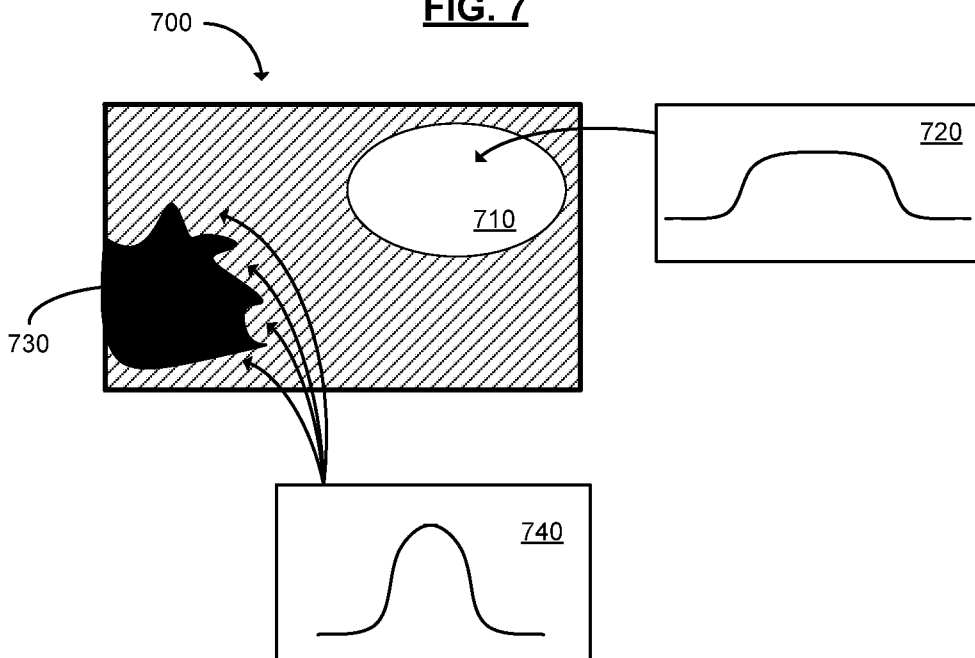
**FIG. 3**



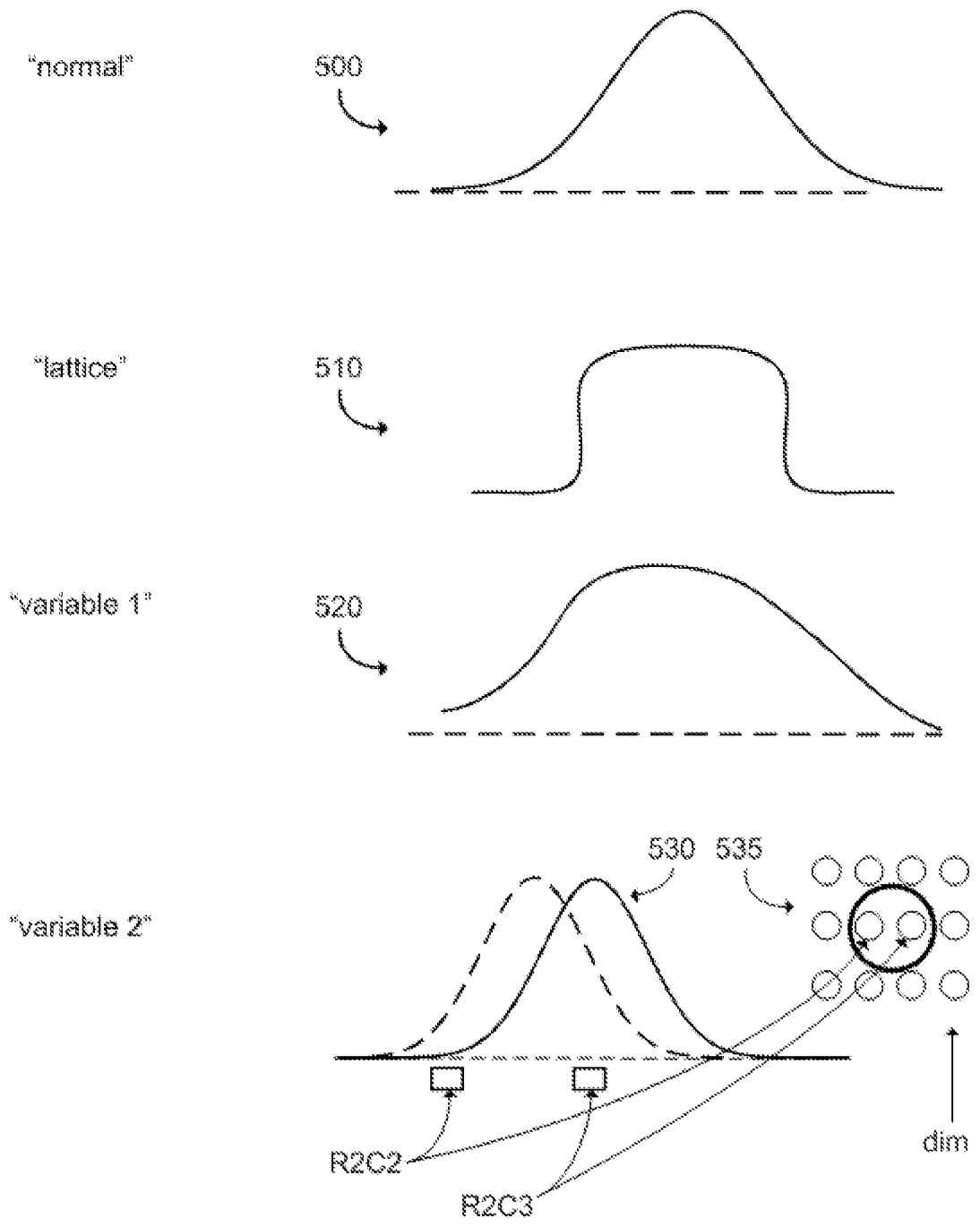
**FIG. 4**



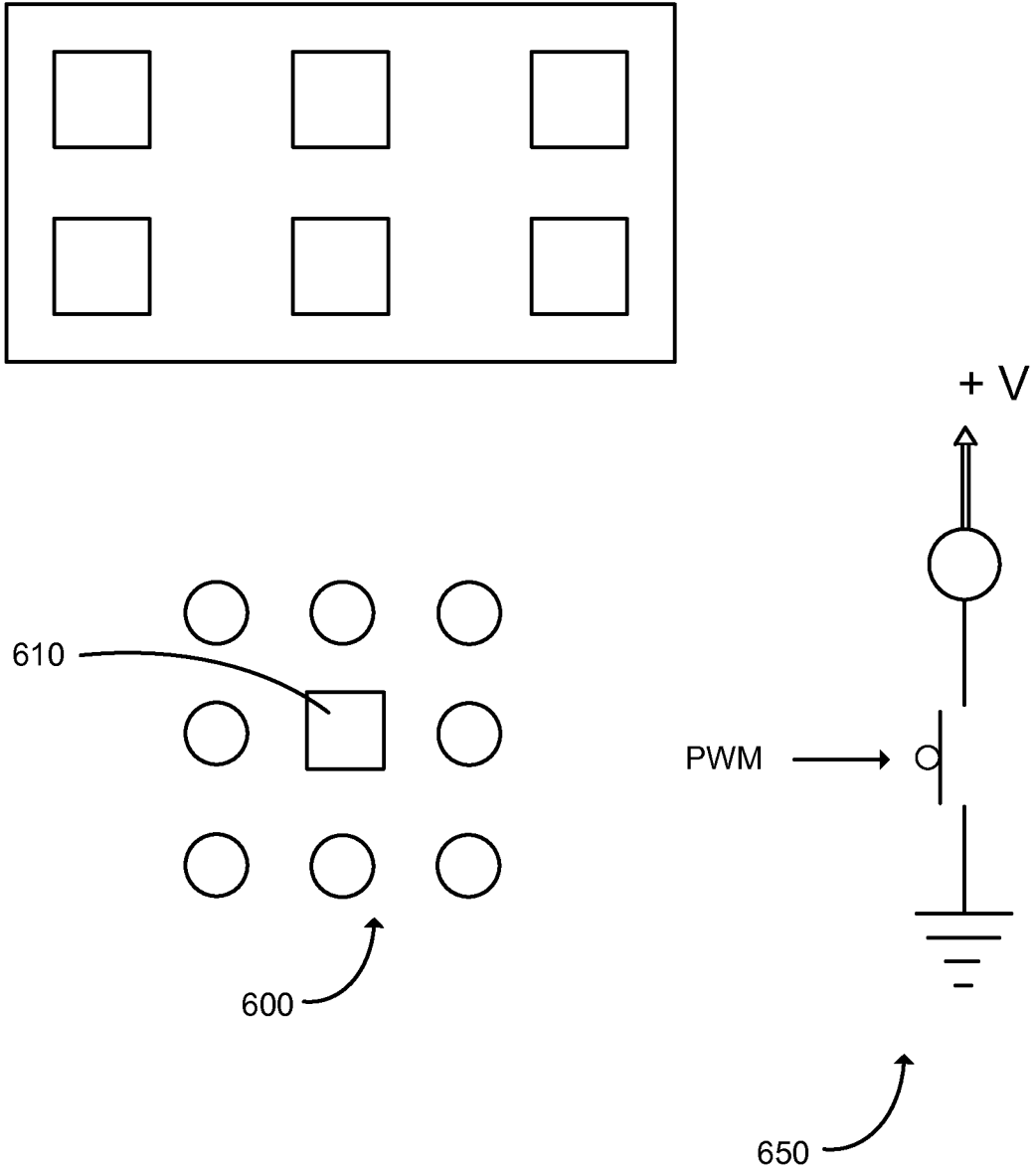
**FIG. 7**



**FIG. 5**

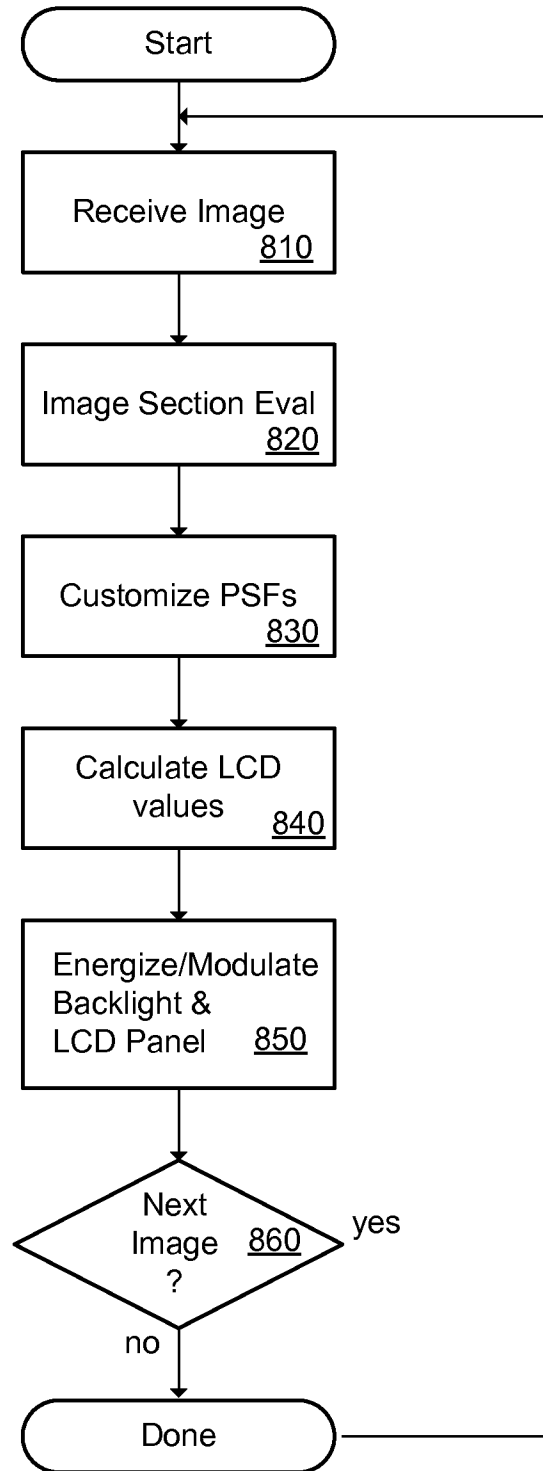


**FIG. 6**

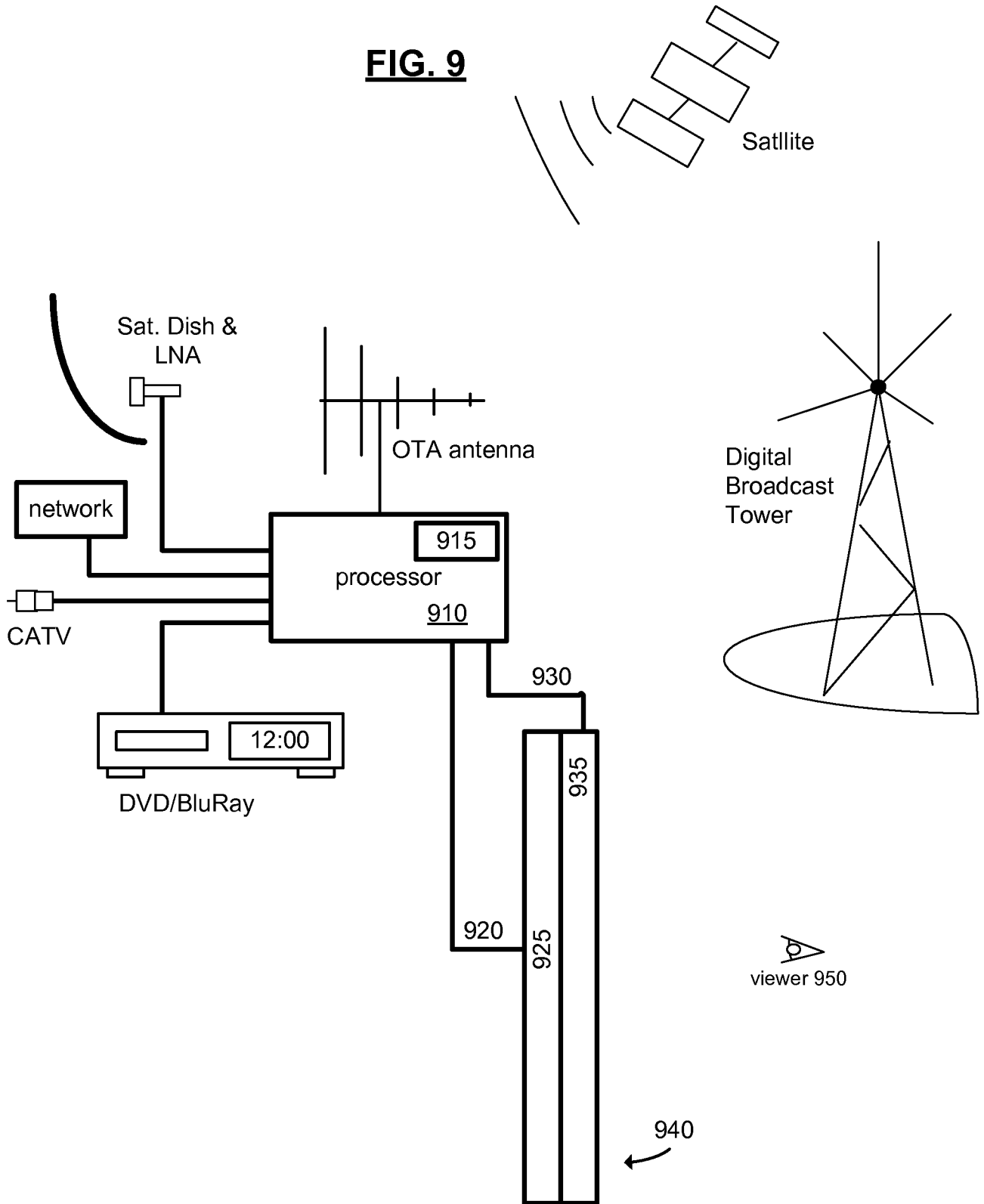


**FIG. 8**

800



**FIG. 9**



# INTERNATIONAL SEARCH REPORT

International application No  
PCT/US2009/063690

**A. CLASSIFICATION OF SUBJECT MATTER**  
INV. G02F1/13357  
ADD. G09G3/34

According to International Patent Classification (IPC) or to both national classification and IPC

**B. FIELDS SEARCHED**

Minimum documentation searched (classification system followed by classification symbols)  
G02F

Documentation searched other than minimum documentation to the extent that such documents are included in the fields searched

Electronic data base consulted during the international search (name of data base and, where practical, search terms used)

EPO-Internal

**C. DOCUMENTS CONSIDERED TO BE RELEVANT**

Category*	Citation of document, with indication, where appropriate, of the relevant passages	Relevant to claim No.
X	US 2006/103621 A1 (FENG XIAO-FAN [US]) 18 May 2006 (2006-05-18) paragraphs [0002], [0010], [0011], [0026] - [0028], [0034] - [0041]	1-17
A	US 2006/120082 A1 (CHOO DAE-HO [KR] ET AL) 8 June 2006 (2006-06-08) the whole document	1-17

Further documents are listed in the continuation of Box C.

See patent family annex.

\* Special categories of cited documents :

"A" document defining the general state of the art which is not considered to be of particular relevance

"E" earlier document but published on or after the international filing date

"L" document which may throw doubts on priority claim(s) or which is cited to establish the publication date of another citation or other special reason (as specified)

"O" document referring to an oral disclosure, use, exhibition or other means

"P" document published prior to the international filing date but later than the priority date claimed

"T" later document published after the international filing date or priority date and not in conflict with the application but cited to understand the principle or theory underlying the invention

"X" document of particular relevance; the claimed invention cannot be considered novel or cannot be considered to involve an inventive step when the document is taken alone

"Y" document of particular relevance; the claimed invention cannot be considered to involve an inventive step when the document is combined with one or more other such documents, such combination being obvious to a person skilled in the art.

"&" document member of the same patent family

Date of the actual completion of the international search

9 February 2010

Date of mailing of the international search report

26/02/2010

Name and mailing address of the ISA/

European Patent Office, P.B. 5818 Patentlaan 2  
NL - 2280 HV Rijswijk  
Tel. (+31-70) 340-2040,  
Fax: (+31-70) 340-3016

Authorized officer

Aichmayr, Günther

# INTERNATIONAL SEARCH REPORT

Information on patent family members

International application No

PCT/US2009/063690

Patent document cited in search report	Publication date	Patent family member(s)	Publication date
US 2006103621 A1	18-05-2006	NONE	
US 2006120082 A1	08-06-2006	JP 2006147573 A	08-06-2006