

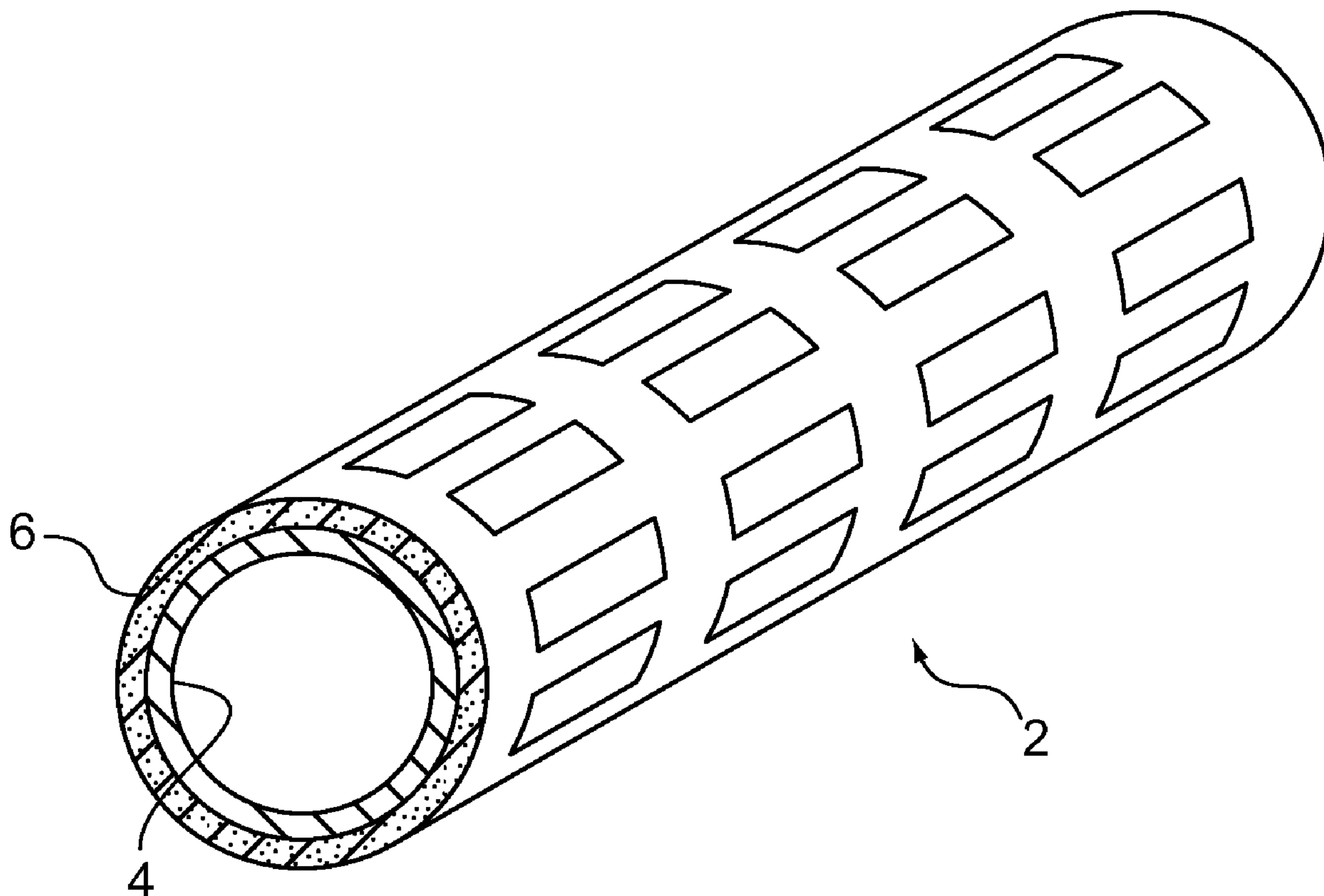

(86) Date de dépôt PCT/PCT Filing Date: 2007/09/14  
 (87) Date publication PCT/PCT Publication Date: 2008/03/20  
 (85) Entrée phase nationale/National Entry: 2009/03/11  
 (86) N° demande PCT/PCT Application No.: US 2007/078450  
 (87) N° publication PCT/PCT Publication No.: 2008/034031  
 (30) Priorité/Priority: 2006/09/15 (US60/844,898)

(51) Cl.Int./Int.Cl. *A61L 31/14* (2006.01),  
*A61L 31/02* (2006.01)  
 (71) Demandeur/Applicant:  
BOSTON SCIENTIFIC LIMITED, BB  
 (72) Inventeurs/Inventors:  
ATANASOSKA, LILIANA, US;  
WEBER, JAN, NL;  
WARNER, ROBERT W., US;  
GROVENDER, AMY, US  
 (74) Agent: SMART & BIGGAR

(54) Titre : ENDOPROTHESES BIODEGRADABLES ET PROCEDES DE FABRICATION  
 (54) Title: BIOERODIBLE ENDOPROSTHESES AND METHODS OF MAKING THE SAME



(57) **Abrégé/Abstract:**

Bioerodible endoprostheses and methods of making the endoprostheses are disclosed. In some embodiments, an endoprosthesis includes a member including a bioerodible material, and an antioxidant carried by the member. Examples of antioxidants include phenols.

(12) INTERNATIONAL APPLICATION PUBLISHED UNDER THE PATENT COOPERATION TREATY (PCT)

(19) World Intellectual Property Organization  
International Bureau(43) International Publication Date  
20 March 2008 (20.03.2008)

PCT

(10) International Publication Number  
**WO 2008/034031 A3**(51) International Patent Classification:  
A61L 31/14 (2006.01) A61L 31/02 (2006.01)(21) International Application Number:  
PCT/US2007/078450(22) International Filing Date:  
14 September 2007 (14.09.2007)

(25) Filing Language: English

(26) Publication Language: English

(30) Priority Data:  
60/844,898 15 September 2006 (15.09.2006) US(71) Applicant (for all designated States except US): **BOSTON SCIENTIFIC SCIMED, INC.** [US/US]; One Scimed Place, Maple Grove, Minnesota 55311-1566 (US).

(72) Inventors; and

(75) Inventors/Applicants (for US only): **ATANASOSKA, Liliana** [US/US]; 5209 Windsor Avenue, Edina, Minnesota 55436 (US). **WEBER, Jan** [NL/NL]; Holdaal 49, NL-6228 GJ Maastricht (NL). **WARNER, Robert W.** [US/US]; 1665 Lamplight Drive, Woodbury, Minnesota 55125 (US). **GROVENDER, Amy** [US/US]; 2564 Branch St., Apt. 15, Middleton, Wisconsin 53562 (US).(74) Agents: **SHIPSIDES, Geoffrey P.** et al.; Fish & Richardson P.C., P.O. Box 1022, Minneapolis, Minnesota 55440-1022 (US).

(81) Designated States (unless otherwise indicated, for every kind of national protection available): AE, AG, AL, AM, AT, AU, AZ, BA, BB, BG, BH, BR, BW, BY, BZ, CA, CH, CN, CO, CR, CU, CZ, DE, DK, DM, DO, DZ, EC, EE, EG, ES, FI, GB, GD, GE, GH, GM, GT, HN, HR, HU, ID, IL, IN, IS, JP, KE, KG, KM, KN, KP, KR, KZ, LA, LC, LK, LR, LS, LT, LU, LY, MA, MD, ME, MG, MK, MN, MW, MX, MY, MZ, NA, NG, NI, NO, NZ, OM, PG, PH, PL, PT, RO, RS, RU, SC, SD, SE, SG, SK, SL, SM, SV, SY, TJ, TM, TN, TR, TT, TZ, UA, UG, US, UZ, VC, VN, ZA, ZM, ZW.

(84) Designated States (unless otherwise indicated, for every kind of regional protection available): ARIPO (BW, GH, GM, KE, LS, MW, MZ, NA, SD, SL, SZ, TZ, UG, ZM, ZW), Eurasian (AM, AZ, BY, KG, KZ, MD, RU, TJ, TM), European (AT, BE, BG, CH, CY, CZ, DE, DK, EE, ES, FI, FR, GB, GR, HU, IE, IS, IT, LT, LU, LV, MC, MT, NL, PL, PT, RO, SE, SI, SK, TR), OAPI (BF, BJ, CF, CG, CI, CM, GA, GN, GQ, GW, ML, MR, NE, SN, TD, TG).

[Continued on next page]

(54) Title: BIOERODIBLE ENDOPROSTHESES AND METHODS OF MAKING THE SAME

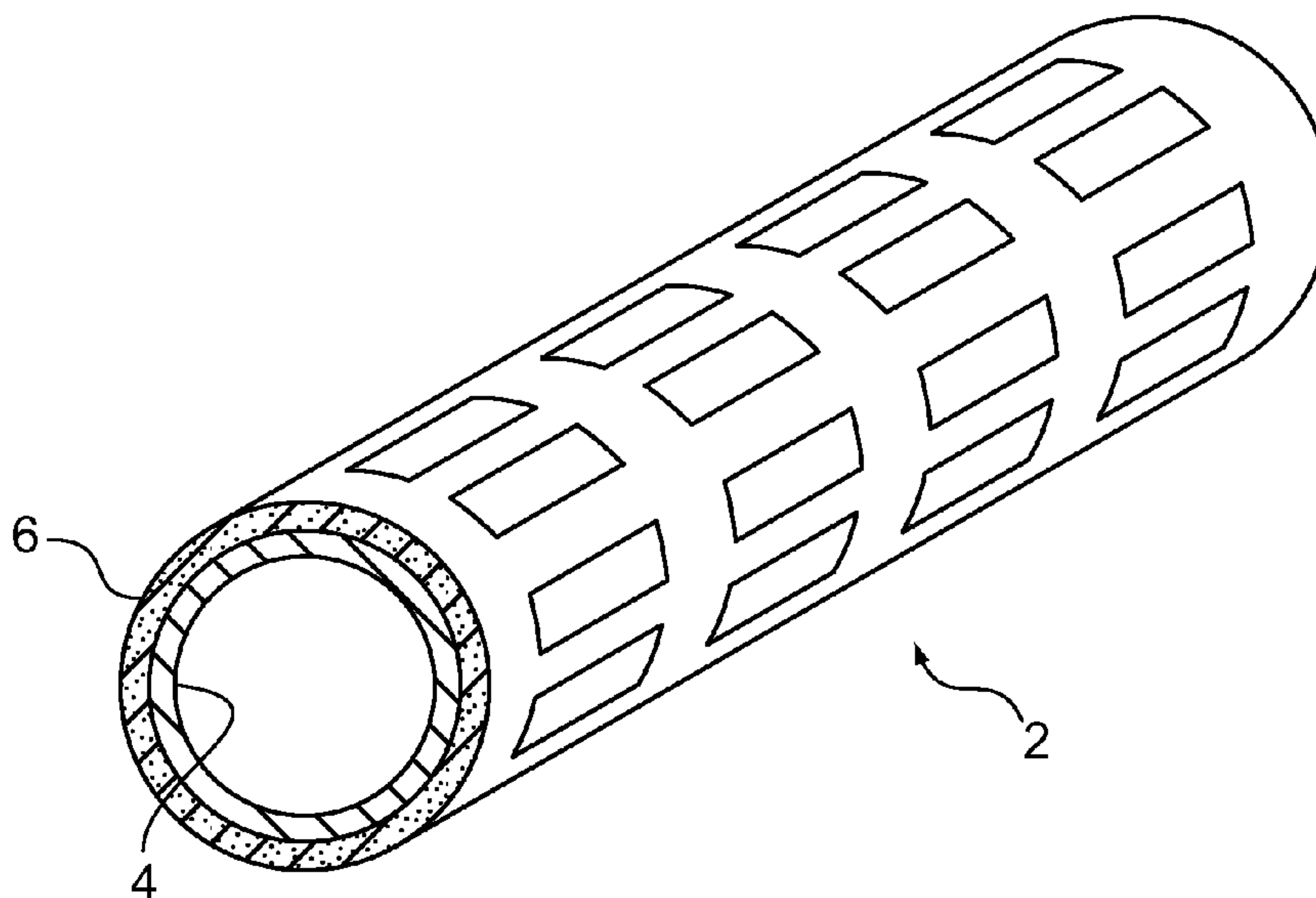

(57) Abstract: Bioerodible endoprostheses and methods of making the endoprostheses are disclosed. In some embodiments, an endoprosthesis includes a member including a bioerodible material, and an antioxidant carried by the member. Examples of antioxidants include phenols.

WO 2008/034031 A3

**WO 2008/034031 A3**



**Declarations under Rule 4.17:**

- *as to applicant's entitlement to apply for and be granted a patent (Rule 4.17(ii))*
- *as to the applicant's entitlement to claim the priority of the earlier application (Rule 4.17(iii))*

- *before the expiration of the time limit for amending the claims and to be republished in the event of receipt of amendments*

**Published:**

- *with international search report*

**(88) Date of publication of the international search report:**

15 January 2009

## BIOERODIBLE ENDOPROSTHESES AND METHODS OF MAKING THE SAME

### CROSS-REFERENCE TO RELATED APPLICATIONS

5           This application claims priority under 35 USC §119(e) to U.S. Provisional Patent Application Serial No. 60/844,898, filed on September 15, 2006, the entire contents of which are hereby incorporated by reference.

### TECHNICAL FIELD

10           The invention relates to bioerodible endoprostheses, and to methods of making the same.

### BACKGROUND

15           The body includes various passageways such as arteries, other blood vessels, and other body lumens. These passageways sometimes become occluded or weakened. For example, the passageways can be occluded by a tumor, restricted by plaque, or weakened by an aneurysm. When this occurs, the passageway can be reopened or reinforced with a medical endoprosthesis. An endoprosthesis is typically a tubular member that is placed in a lumen in the body. Examples of endoprostheses include stents, covered stents, and stent-  
20           grafts.

          Endoprostheses can be delivered inside the body by a catheter that supports the endoprosthesis in a compacted or reduced-size form as the endoprosthesis is transported to a desired site. Upon reaching the site, the endoprosthesis is expanded, e.g., so that it can contact the walls of the lumen.

25           The expansion mechanism may include forcing the endoprosthesis to expand radially. For example, the expansion mechanism can include the catheter carrying a balloon, which carries a balloon-expandable endoprosthesis. The balloon can be inflated to deform and to fix the expanded endoprosthesis at a predetermined position in contact with the lumen wall. The balloon can then be deflated, and the catheter withdrawn from the lumen.

It is sometimes desirable for an implanted endoprosthesis to erode over time within the passageway. For example, a fully erodible endoprosthesis does not remain as a permanent object in the body, which may help the passageway recover to its natural condition. Erodible endoprostheses can be formed from, e.g., a polymeric material, such as polylactic acid, or from a metallic material, such as magnesium, iron or an alloy thereof.

### SUMMARY

The invention relates to bioerodible endoprostheses and methods of making the endoprostheses.

10 In one aspect, the invention features an endoprosthesis including a member. The member includes a bioerodible material and an antioxidant carried by the member.

In another aspect, the invention features a method of making an endoprosthesis. The method includes incorporating a bioerodible material with an antioxidant to form at least a portion of the endoprosthesis.

15 Embodiments can include one or more of the following features.

The endoprosthesis can include a carrier layer carrying the antioxidant. The antioxidant can be on a surface of the member. The antioxidant can be within a matrix or a carrier material. The carrier can include pores. The carrier can be bioerodible or non-bioerodible. The carrier can be a metal and/or a polymer.

20 In some embodiments, the antioxidant is encapsulated by the bioerodible material. The bioerodible material can be iron or magnesium. The antioxidant can be in a layer having a thickness of from about 0.5 micrometer to about 10 micrometers. The antioxidant can include a phenol. The antioxidant can include an eugenol, an isoeugenol, and/or an acetyl-eugenol.

25 The endoprosthesis can further include a drug carried by the member. In some embodiments, the member includes a tubular member constructed to maintain patency of a body vessel. The endoprosthesis can be in the form of a stent.

In some embodiments, the method includes adsorbing the antioxidant on the surface. In some embodiments, the bioerodible material is in the form of a tubular member, and the antioxidant is incorporated on a surface of the tubular member. The bioerodible material can be iron, magnesium, and/or an alloy of iron or magnesium. In some embodiments, the

30

bioerodible material is in the form of a tubular member, and the antioxidant is incorporated in a select portion of the tubular member. In certain embodiments, the antioxidant is in a particle encapsulated by a bioerodible material. The particle can include zinc oxide. In some embodiments, at least a portion of the endoprosthesis can further include a drug. The method  
5 can further include incorporating a drug with the portion.

Embodiments may have one or more of the following advantages. Embodiments feature an endoprosthesis, e.g. a coronary stent, that includes a bioerodible portion, such as the body of the stent capable of initially maintaining lumen patency, and an antioxidant. In  
10 embodiments, an endoprosthesis is coated with an antioxidant. The antioxidant can reduce (e.g., inhibit) erosion (e.g., corrosion) and can allow for control of biodegradation of metallic endoprosthesis materials. As an example, the antioxidant can allow an endoprosthesis to maintain structural integrity for a longer duration, which can decrease elastic recoil after endoprosthesis expansion. The antioxidant can reduce (e.g., inhibit) lipid peroxidation and can allow for a decrease in restenosis after coronary angioplasty.

15 The endoprostheses may not need to be removed from a lumen after implantation. The endoprostheses can have a low thrombogenicity and high initial strength. The endoprostheses can exhibit reduced spring back (recoil) after expansion. Lumens implanted with the endoprostheses can exhibit reduced restenosis. The rate of erosion of different portions of the endoprostheses can be controlled, allowing the endoprostheses to erode in a  
20 predetermined manner and reducing, e.g., the likelihood of uncontrolled fragmentation. For example, the predetermined manner of erosion can be from an inside of the endoprosthesis to an outside of the endoprosthesis, or from a first end of the endoprosthesis to a second end of the endoprosthesis.

An erodible or bioerodible endoprosthesis, e.g., a stent, refers to an endoprosthesis, or  
25 a portion thereof, that exhibits substantial mass or density reduction or chemical transformation, after it is introduced into a patient, e.g., a human patient. Mass reduction can occur by, e.g., dissolution of the material that forms the endoprosthesis and/or fragmenting of the endoprosthesis. Chemical transformation can include oxidation/reduction, hydrolysis, substitution, and/or addition reactions, or other chemical reactions of the material from which  
30 the endoprosthesis, or a portion thereof, is made. The erosion can be the result of a chemical and/or biological interaction of the endoprosthesis with the body environment, e.g., the body

itself or body fluids, into which it is implanted and/or erosion can be triggered by applying a triggering influence, such as a chemical reactant or energy to the endoprosthesis, e.g., to increase a reaction rate. For example, an endoprosthesis, or a portion thereof, can be formed from an active metal, e.g., Mg or Ca or an alloy thereof, and which can erode by reaction with water, producing the corresponding metal oxide and hydrogen gas (a redox reaction). For example, an endoprosthesis, or a portion thereof, can be formed from an erodible or bioerodible polymer, or an alloy or blend erodible or bioerodible polymers which can erode by hydrolysis with water. The erosion occurs to a desirable extent in a time frame that can provide a therapeutic benefit. For example, in embodiments, the endoprosthesis exhibits substantial mass reduction after a period of time which a function of the endoprosthesis, such as support of the lumen wall or drug delivery is no longer needed or desirable. In particular embodiments, the endoprosthesis exhibits a mass reduction of about 10 percent or more, e.g. about 50 percent or more, after a period of implantation of one day or more, e.g. about 60 days or more, about 180 days or more, about 600 days or more, or 1000 days or less. In embodiments, the endoprosthesis exhibits fragmentation by erosion processes. The fragmentation occurs as, e.g., some regions of the endoprosthesis erode more rapidly than other regions. The faster eroding regions become weakened by more quickly eroding through the body of the endoprosthesis and fragment from the slower eroding regions. The faster eroding and slower eroding regions may be random or predefined. For example, faster eroding regions may be predefined by treating the regions to enhance chemical reactivity of the regions. Alternatively, regions may be treated to reduce erosion rates, e.g., by using coatings. In embodiments, only portions of the endoprosthesis exhibits erodibility. For example, an exterior layer or coating may be erodible, while an interior layer or body is non-erodible. In embodiments, the endoprosthesis is formed from an erodible material dispersed within a non-erodible material such that after erosion, the endoprosthesis has increased porosity by erosion of the erodible material.

Erosion rates can be measured with a test endoprosthesis suspended in a stream of Ringer's solution flowing at a rate of 0.2 mL/second. During testing, all surfaces of the test endoprosthesis can be exposed to the stream. For the purposes of this disclosure, Ringer's solution is a solution of recently boiled distilled water containing 8.6 gram sodium chloride, 0.3 gram potassium chloride, and 0.33 gram calcium chloride per liter.

In some embodiments, an endoprosthesis with an antioxidant layer is relatively easy to make. An antioxidant and a polymer can be dissolved in a solvent and applied to an endoprosthesis. An antioxidant and a polymer can be blended together, and/or can be formed into a composite, and applied to an endoprosthesis. An antioxidant can be applied directly to an endoprosthesis, which can have open or closed pores. An antioxidant can be incorporated with particles and applied to an endoprosthesis.

All publications, patent applications, patents, and other references mentioned herein are incorporated by reference herein in their entirety.

Other aspects, features and advantages will be apparent from the description of the preferred embodiments thereof and from the claims.

#### DESCRIPTION OF DRAWINGS

FIG. 1A is a perspective view of an embodiment of an endoprosthesis.

FIG. 1B is a cross-sectional view of an embodiment of an endoprosthesis.

FIG. 2A is a perspective view of an embodiment of an endoprosthesis.

FIG. 2B is a cross-sectional view of an embodiment of an endoprosthesis.

FIG. 3A is a perspective view of an embodiment of an endoprosthesis.

FIG. 3B is a cross-sectional view of an embodiment of an endoprosthesis.

FIG. 3C is a cross-sectional view of another embodiment of an endoprosthesis.

FIG. 4 is an enlarged cross-sectional view of a region of an endoprosthesis.

FIG. 5 is an enlarged cross-sectional view of a region of an embodiment of an endoprosthesis.

FIG. 6 is an enlarged cross-sectional view of a region of an embodiment of an endoprosthesis.

FIG. 7 is a cross-sectional view of an embodiment of an endoprosthesis.

FIG. 8 is an enlarged cross-sectional view of a region of an embodiment of an endoprosthesis.

FIG. 9 is an enlarged cross-sectional view of a region of an embodiment of an endoprosthesis.

FIG. 10 is an enlarged cross-sectional view of an embodiment of an endoprosthesis

FIG. 11 a perspective view of an embodiment of an endoprosthesis.



FIG. 12 is a perspective view of an embodiment of an endoprosthesis.

FIG. 13 is a sequence illustrating a method of making an endoprosthesis.

#### DETAILED DESCRIPTION

5 Referring to FIGS. 1A and 1B endoprosthesis 2 (as shown, a stent) includes a bioerodible layer 4 and an antioxidant-containing layer 6 (“antioxidant layer 6”) disposed radially outward and on a surface of the bioerodible layer. Bioerodible layer 4, which can include a bioerodible material (e.g., a metal) such as a magnesium alloy, is a tubular body capable of maintaining the patency of a bodily lumen after implantation and is capable of  
10 eroding within the bodily lumen. Antioxidant layer 6 provides therapeutic benefits, such as inhibiting restenosis as well as affecting (e.g., reducing or inhibiting) the erosion of bioerodible layer 4 to allow the endoprosthesis to maintain structural integrity (e.g., patency) for a longer duration. Examples of antioxidants in antioxidant layer 6 include phenolic compounds (e.g., isoeugenol, eugenol, and acetyl eugenol), polyphenols, phenols, and any  
15 mixtures thereof. As shown, antioxidant layer 6 is disposed radially outward of bioerodible layer 4, but alternatively or additionally, the antioxidant layer can be disposed radially inward of the bioerodible layer.

Antioxidants can inhibit or reduce oxidative processes caused by oxygen or free radicals. The use of an antioxidant in an erodible endoprosthesis can provide a number of  
20 advantages. The antioxidant can inhibit restenosis by inhibiting lipid peroxidation. Antioxidants such as eugenol compounds can have an inhibitory effect on LDL suppression of free radical cascade of lipid peroxidation and reduction of LDL to its receptor, as well as provide anti-inflammatory effects. In addition, the antioxidant presence on its own as a coating or in a carrier with another material acts as a barrier that modifies the exposure of the  
25 bioerodible endoprosthesis to body fluids and thus the degradation processes which occur upon exposure to body fluids. Moreover, the presence of an antioxidant can chemically inhibit corrosive degradation, particularly of metals. Without being bound by theory, it is believed that in a biological fluid, an antioxidant can reduce (e.g., inhibit) free radical reactions by decreasing the level of active products from oxygen reduction and/or  
30 sequestering (e.g., binding to a protein) a transition metal group such as Fe and Cu to reduce the formation of oxidants. Further discussion of antioxidants is provided in Chaieb *et al.*,

*Applied Surface Science*, 2005, 246, 199; Lee *et al.*, *Journal of Dentistry*, 2000, 28, 69; Satoh *et al.*, *Anticancer Res.*, 1998, 18, 1549; Damiani *et al.*, *Vascular Pharmacol.* 2003, 40, 59; Stoclet *et al.*, *European Journal of Pharmacology*, 2005, 500, 461; Ito *et al.*, *Food and Chemical Toxicology*, 2005, 43, 461; Naderi *et al.*, *Molecular and Cellular Biochemistry*, 2004, 267, 59; Molnar *et al.*, *International Immunopharmacology*, 2005, 5, 849; Kim *et al.*, *Circ. J.*, 2005, 69, 101; Andión *et al.*, *Corrosion Science*, 2002, 44, 2805-2816; and Ou *et al.*, *Food and Chemical Toxicology*, 2006, 44, 1485-1495, the entire contents of each of which is hereby incorporated by reference.

As an example, an antioxidant can be low-molecular weight compounds (e.g., isoeugenol, eugenol, acetyl eugenol, polyphenols, phenols (including antioxidants of the phenolic class of compounds such as phenols, polyphenols, and phenolic compounds), tocopherols, anethol, geraniol, limonene, linalool, p-cymol, pulegone, thymol, ubiquinol-10, ascorbic acid,  $\beta$ -carotene, lycopene, glutathione, uric acid, bilirubin, carvediol, *Curcuma longa*, and *Ocimum sanctum*. Classes of antioxidants can include phenols, phenolic acids, flavonoids, anthocyanins, catechins, flavones, flavonols, flavanones, isoflavones, lignins, proanthocyanidins, procyanidins, stilbenes, tannins, spice antioxidants, and plant-derived antioxidants. In some embodiments, an antioxidant is a high-molecular weight compound such as a protein (e.g., albumin, transferrin, haptoglobin, haemopexin, caeruloplasmin, ferritin, superoxide dismutase, catalase, glutathione reductase, glutathione peroxidase, etc.) and/or a polymer (e.g., polymeric phenols). In some embodiments, the antioxidant is polymeric. The polymeric antioxidant can be provided as a layer directly on the bioerodible layer. In embodiments, the polymeric antioxidant layer is directly deposited onto an endoprosthesis by electropolymerization, and/or the polymeric antioxidant layer is dissolved in a solvent and applied to the endoprosthesis. A plurality of different antioxidants can be used.

The antioxidant compound can be provided as a layer directly on the bioerodible layer or incorporated into the bioerodible layer, or incorporated into a bioerodible or nonbioerodible carrier layer on the bioerodible material. The antioxidant can be released from the carrier by diffusion through the carrier and/or erosion of the carrier in the case where a bioerodible carrier is used. The antioxidant can be noncovalently bonded, e.g. adsorbed, or covalently bonded to the carrier or the bioerodible material, e.g. by

copolymerization with the carrier. Further examples of antioxidants are described, for example, in Ivanova *et al.*, *Experimental Pathology and Parasitology*, 2000, 4, 49; Frei, B., *Proceedings – Society for Experimental Biology and Medicine*, 1999, 222, 196; Mohanty *et al.*, *BMC Complementary and Alternative Medicine*, 2006, 6:3; Suhaj, M., *Journal of Food Composition and Analysis*, 2006, 19, 531-537; Ratnam *et al.*, *Journal of Controlled Release*, 2006, 113, 189-207; Gurib-Fakim, A., *Molecular Aspects of Medicine*, 2006, 27, 1-93; Arts *et al.*, *Am. J. Clin. Nutr.*, 2005, 81(1), 317S-325S; Wallerath *et al.*, *Nitric Oxide*, 2005, 12(2), 97-104; Grassi *et al.*, *Am. J. Clin. Nutr.*, 2005, 81(3), 611-614; Kim *et al.*, *Crit. Rev. Food Sci. Nutr.*, 2004, 44(4), 253-273; Lambert *et al.*, *Am. J. Clin. Nutr.*, 2005, 81(1), 284S-291S; Moskaug *et al.*, *Am. J. Clin. Nutr.*, 2005, 81(1), 277S-283S; and Williamson *et al.*, *Am. J. Clin. Nutr.*, 2005, 81(1), 243S-255S.

In FIGS. 1A and 1B, antioxidant layer 6 has an antioxidant (shading) distributed uniformly within a matrix of a biocompatible carrier 7. Suitable carriers include, for example, bioerodible or non bioerodible polymers or metals. A bioerodible carrier (e.g., a bioerodible polymer) can erode over time and expose the incorporated antioxidant for gradual release. A bioerodible carrier can inhibit direct contact of body fluids with bioerodible layer 4 and reduce the bioerosion rate of the endoprosthesis. Suitable bioerodible polymer carriers include polylactic acid (PLA), polylactic glycolic acid (PLGA), polyanhydrides (e.g., poly(ester anhydride)s, fatty acid-based polyanhydrides, amino acid-based polyanhydrides), polyesters, polyester-polyanhydride blends, polycarbonate-polyanhydride blends, and/or combinations thereof. Bioerodible polymers such as polyanhydrides are described, for example, in Kumar *et al.*, *Advanced Drug Delivery Reviews*, 2002, 54, 889. Bioerodible polymers are also described in U.S.S.N. 10/958,435 (U.S. Patent Application Publication No. 2005/0216074), filed October 5, 2004. The antioxidant and the polymer can be dissolved in a solvent and applied to bioerodible layer 4, the antioxidant and the polymer can be blended together and applied to the bioerodible layer, and/or the antioxidant and the polymer can be formed into a composite in a solvent and applied to the bioerodible layer. The antioxidant can be applied (e.g., adsorbed) to antioxidant layer using, for example, vapor phase adsorption and solution phase adsorption methods (such as solution impregnation). Varying amounts of the antioxidant can be dispersed (uniformly or non-uniformly) within antioxidant layer 6. For example, the

antioxidant can be present from about 0.5 percent by weight of the antioxidant layer 6 (e.g., from about 1 percent by weight, from about 2 percent by weight, from about 5 percent by weight, from about 10 percent by weight, from about 15 percent by weight, from about 20 percent by weight, from about 25 percent by weight) to about 30 percent by weight of the antioxidant layer (e.g., to about 25 percent by weight, to about 20 percent by weight, to about 15 percent by weight, to about 10 percent by weight, to about 5 percent by weight, to about 2 percent by weight). The carrier can include one or more bioerodible materials and/or one or more non-bioerodible materials that has a different chemical composition than a composition of material in bioerodible layer 4.

Referring to FIGS. 2A and 2B, endoprosthesis 2' includes a bioerodible layer 4' and an antioxidant layer 6' radially outward of the bioerodible layer 4'. The antioxidant layer 6' includes (e.g., is formed of) a bioerodible or non-bioerodible carrier 7' having a plurality of pores 8. The antioxidant is dispersed (e.g., sorbed) in the pores in antioxidant layer 6'. Pores 8 increase the total free volume and surface area of antioxidant layer 6', and allow more antioxidant to be loaded in and delivered from antioxidant layer 6'. The antioxidant layer can be formed of a bioerodible or non-bioerodible metal, polymer or ceramic in which pores are created. For example, the carrier can be formed of the same material or a different material as the bioerodible layer 4'. For example, carrier and the bioerodible layer can be formed of the same metal. Antioxidant layer 6' can be made by forming pores 8 and applying the antioxidant to the porous outer surface. In some embodiments, a first layer of carrier material is formed on the surface of the bioerodible layer and pores are formed by creating a number of holes (e.g., by laser ablation) and the holes are filled or partially filled with an antioxidant 6. A second layer of a same or different polymer can be coated (e.g., by spraying) onto the endoprosthesis. Pores can also be formed during the coating process by techniques discussed below. The pores can be formed directly into the surface of the bioerodible layer 4' without the use of a carrier. Pores 8 can have an average diameter of from about 10 nm (e.g., from about 20 nm, from about 50 nm, from about 100 nm, from about 200 nm, from about 500 nm, from about 700 nm, from about 1  $\mu\text{m}$ , from about 1.5  $\mu\text{m}$ , from about 2  $\mu\text{m}$ , from about 2.5  $\mu\text{m}$ , from about 3  $\mu\text{m}$ , from about 3.5  $\mu\text{m}$ , from about 4  $\mu\text{m}$ , from about 4.5  $\mu\text{m}$ ) to about 10  $\mu\text{m}$  (e.g., to about 9  $\mu\text{m}$ , to about 8  $\mu\text{m}$ , to about 7  $\mu\text{m}$ , to about 6  $\mu\text{m}$ , to about 5  $\mu\text{m}$ , to about 4.5  $\mu\text{m}$ , to about 4  $\mu\text{m}$ , to about 3  $\mu\text{m}$ , to about 2.5  $\mu\text{m}$ ,

to about 2  $\mu\text{m}$ , to about 1.5  $\mu\text{m}$ , to about 1  $\mu\text{m}$ , to about 750 nm, to about 500 nm, to about 250 nm, to about 100 nm, to about 75 nm, to about 50 nm, to about 25 nm). Pores 8 can have an average surface area of from about 300  $\text{nm}^2$  (e.g. from about 1,000  $\text{nm}^2$ , from about 5,000  $\text{nm}^2$ , from about 30,000  $\text{nm}^2$ , from about 0.5  $\mu\text{m}^2$ , from about 6  $\mu\text{m}^2$ , from about 10  $\mu\text{m}^2$ ,  
5 from about 20  $\mu\text{m}^2$ , from about 30  $\mu\text{m}^2$ , from about 40  $\mu\text{m}^2$ , from about 50  $\mu\text{m}^2$ , from about 65  $\mu\text{m}^2$ ) to about 350  $\mu\text{m}^2$  (e.g., to about 300  $\mu\text{m}^2$ , to about 250  $\mu\text{m}^2$ , to about 200  $\mu\text{m}^2$ , to about 150  $\mu\text{m}^2$ , to about 100  $\mu\text{m}^2$ , to about 70  $\mu\text{m}^2$ , to about 65  $\mu\text{m}^2$ , to about 50  $\mu\text{m}^2$ , to about 40  $\mu\text{m}^2$ , to about 30  $\mu\text{m}^2$ , to about 20  $\mu\text{m}^2$ , to about 10  $\mu\text{m}^2$ , to about 6  $\mu\text{m}^2$ , to about 0.5  $\mu\text{m}^2$ , to about 30,000  $\text{nm}^2$ , to about 5,000  $\text{nm}^2$ , to about 1000  $\text{nm}^2$ ). Pores 8 can also be  
10 expressed by average volume. In some embodiments, pores 8 can be from about 500  $\text{nm}^3$  (e.g., from about 0.00005  $\mu\text{m}^3$ , from about 0.0005  $\mu\text{m}^3$ , from about 0.005  $\mu\text{m}^3$ , from about 0.05  $\mu\text{m}^3$ , from about 0.5  $\mu\text{m}^3$ , from about 1  $\mu\text{m}^3$ , from about 5  $\mu\text{m}^3$ , from about 35  $\mu\text{m}^3$ , from about 50  $\mu\text{m}^3$ ) to about 550  $\mu\text{m}^3$  (e.g., to about 450  $\mu\text{m}^3$ , to about 300  $\mu\text{m}^3$ , to about 200  $\mu\text{m}^3$ , to about 100  $\mu\text{m}^3$ , to about 75  $\mu\text{m}^3$ , to about 40  $\mu\text{m}^3$ , to about 10  $\mu\text{m}^3$ , to about 5  $\mu\text{m}^3$ ,  
15 to about 1  $\mu\text{m}^3$ , to about 0.5  $\mu\text{m}^3$ , to about 0.05  $\mu\text{m}^3$ , to about 0.005  $\mu\text{m}^3$ , to about 0.00005  $\mu\text{m}^3$ ). Pores can occupy a portion of antioxidant layer 6'. In some embodiments, pores range from about 1% by volume of the antioxidant layer (e.g., from about 5% by volume, from about 10% by volume, from about 25% by volume, from about 50% by volume) to about 75% by volume of the antioxidant layer (e.g., to about 60% by volume, to about 50% by  
20 volume, to about 40% by volume, to about 30% by volume, to about 25% by volume, to about 20% by volume, to about 10% by volume, to about 5% by volume. The antioxidant can be applied (e.g., adsorbed) to antioxidant layer 6' using, for example, vapor phase adsorption and solution phase adsorption methods (such as solution impregnation). The antioxidant can be sorbed (uniformly or non-uniformly) within antioxidant layer 6' from  
25 about 0.5% by weight of the antioxidant layer (e.g., from about 1% by weight, from about 5% by weight, from about 10% by weight, from about 20% by weight, from about 30% by weight, from about 40% by weight) to about 50% by weight of the antioxidant layer (e.g., to about 45% by weight, to about 40% by weight, to about 30% by weight, to about 25% by weight, to about 15% by weight, to about 10% by weight, to about 5% by weight, to about  
30 2% by weight, to about 1% by weight).

Referring to FIGS. 3A, 3B, and 3C, endoprosthesis 2'' and 2''' include particles 10, 10', which carry one or more antioxidants. Particles 10, 10' can be dispersed throughout an endoprosthesis, or can be dispersed in an antioxidant layer including a carrier of the types discussed above on an endoprosthesis. Referring to FIGS. 3A and 3B, endoprosthesis 2'' includes a bioerodible layer 4'', and an antioxidant layer 6'' including particles 10 dispersed in a carrier 7'' of the types described above. Referring to FIG. 3C, endoprosthesis 2''' includes particles 10' dispersed throughout the erodible layer 4' of the endoprosthesis. In other embodiments, the particles are absorbed or bonded to the surface of the erodible layer. The particles can include (e.g., is formed of) a bioerodible material, such as zinc oxide, poly( $\gamma$ -benzyl-L-glutamate) (PBLG), poly( $\beta$ -benzyl-L-aspartate) (PBLA), poly-D,L-lactide-co-glycolide (PLGA), and polylactic acid (PLA), that encapsulates the antioxidant and allows the antioxidant to be delivered to the body. Particles 10 (e.g., nanoparticles) can have an average diameter of from about 100 nm (from about 200 nm, from about 400nm, from about 600 nm, from about 1  $\mu$ m, from about 2  $\mu$ m, from about 3  $\mu$ m, from about 4  $\mu$ m) to about 5  $\mu$ m (to about 4.5  $\mu$ m, to about 4  $\mu$ m, to about 3.5  $\mu$ m, to about 3  $\mu$ m, to about 2  $\mu$ m, to about 1  $\mu$ m, to about 800 nm, to about 500 nm, to about 300 nm, to about 200 nm). Particles 10 (e.g., nanoparticles) can also be expressed by volume. In some embodiments, particles 10 can have a volume of from about 0.0005  $\mu$ m<sup>3</sup> (e.g., from about from about 0.005  $\mu$ m<sup>3</sup>, from about 0.05  $\mu$ m<sup>3</sup>, from about 0.5  $\mu$ m<sup>3</sup>, from about 5  $\mu$ m<sup>3</sup>, from about 50  $\mu$ m<sup>3</sup>) to about 70  $\mu$ m<sup>3</sup> (e.g., to about 60  $\mu$ m<sup>3</sup>, to about 50  $\mu$ m<sup>3</sup>, to about 5  $\mu$ m<sup>3</sup>, to about 0.5  $\mu$ m<sup>3</sup>, to about 0.05  $\mu$ m<sup>3</sup>, to about 0.005  $\mu$ m<sup>3</sup>, to about 0.0025  $\mu$ m<sup>3</sup>). The antioxidant can be present in varying amounts within the particles. For example, the antioxidant can be present from about 5 weight percent of particles 10 (e.g., from about 10 weight percent, from about 15 weight percent, from about 20 weight percent, from about 25 weight percent) to about 30 weight percent of particles 10 (e.g., to about 25 weight percent, to about 20 weight percent, to about 15 weight percent, to about 10 weight percent, to about 7 weight percent). Prior to implantation, particles 10 can be present from about 0.5 weight percent of antioxidant layer 6'' (e.g., from about 1 weight percent, from about 2 weight percent, from about 5 weight percent, from about 10 weight percent, from about 15 weight percent) to about 20 weight percent of antioxidant layer 6'' (e.g., to about 17 weight percent, to about 15 weight percent, to about 10 weight percent, to about 5 weight percent, to about 3 weight percent, to about 2 weight percent). Particles 10

can be substantially spherical or any other shape. Suitable processes for making particles include spraying (e.g., electrospraying), emulsion processes, and dispersion polymerization. Further processes for making particles are described, for example, in Jiang, S.B., *Materials Science and Engineering*, 2006, 418, 199.

5 Referring now to FIG. 4, the thicknesses for bioerodible layer 4, 4', 4'' and antioxidant layer 6, 6', 6'' is illustrated. In some embodiments, bioerodible layer 4, 4', 4'' has a total thickness ( $T_b$ ) that is from about 5  $\mu\text{m}$  (e.g., from about 10  $\mu\text{m}$ , from about 20  $\mu\text{m}$ , from about 30  $\mu\text{m}$ , from about 40  $\mu\text{m}$ , from about 50  $\mu\text{m}$ , from about 60  $\mu\text{m}$  from about 80  $\mu\text{m}$ , from about 100  $\mu\text{m}$ ) to about 200  $\mu\text{m}$  (e.g., to about 175  $\mu\text{m}$ , to about 150  $\mu\text{m}$ , to about 100  $\mu\text{m}$ , to about 85  $\mu\text{m}$ , to about 75  $\mu\text{m}$ , to about 50  $\mu\text{m}$ , to about 35  $\mu\text{m}$ , to about 20  $\mu\text{m}$ , to about 15  $\mu\text{m}$ ). In some embodiments, antioxidant layer 6, 6', 6'' has a total thickness ( $T_a$ ) that is from about 0.5  $\mu\text{m}$  (e.g., from about 1  $\mu\text{m}$ , from about 2  $\mu\text{m}$ , from about 3  $\mu\text{m}$ , from about 4  $\mu\text{m}$ , from about 5  $\mu\text{m}$ , from about 6  $\mu\text{m}$ , from about 7  $\mu\text{m}$ , from about 8  $\mu\text{m}$ ) to about 10  $\mu\text{m}$  (e.g., to about 9  $\mu\text{m}$ , to about 8  $\mu\text{m}$ , to about 7  $\mu\text{m}$ , to about 6  $\mu\text{m}$ , to about 5  $\mu\text{m}$ , to about 4  $\mu\text{m}$ , to about 3  $\mu\text{m}$ , to about 2  $\mu\text{m}$ , to about 1  $\mu\text{m}$ ). Total  $T_t$  can be from about 10  $\mu\text{m}$  (e.g., from about 20  $\mu\text{m}$ , from about 30  $\mu\text{m}$ , from about 40  $\mu\text{m}$ , from about 50  $\mu\text{m}$ , from about 60  $\mu\text{m}$  from about 80  $\mu\text{m}$ , from about 100  $\mu\text{m}$ ) to about 200  $\mu\text{m}$  (e.g., to about 150  $\mu\text{m}$ , to about 100  $\mu\text{m}$ , to about 85  $\mu\text{m}$ , to about 75  $\mu\text{m}$ , to about 50  $\mu\text{m}$ , to about 35  $\mu\text{m}$ , to about 20  $\mu\text{m}$ , to about 15  $\mu\text{m}$ ).

20 The thicknesses for bioerodible layer 4, 4', 4'' and antioxidant layer 6, 6', 6'' can also be expressed relative to the total thickness ( $T_t$ ) of endoprosthesis 2, 2', 2''. In some embodiments, bioerodible layer 4, 4', 4'' has a total thickness  $T_b$  that is from about 10 percent of  $T_t$  (e.g., from about 35 percent, from about 60 percent, from about 70%, from about 80 percent) to about 90% of  $T_t$  (e.g., to about 80%, to about 70%, to about 50%. to about 35%, to about 15%, to about 10%). In some embodiments, antioxidant layer 6, 6', 6'' has a total thickness  $T_a$  that is from about 10 percent of  $T_t$  (e.g., from about 35 percent, from about 60 percent, from about 80 percent) to about 90 percent of  $T_t$  (e.g., to about 80%, to about 75 percent, to about 50 percent, to about 45%, to about 35%, to about 25 percent, to about 15%, to about 10%, to about 5%).

30 Referring to Figs. 5 and 6, within an antioxidant layer, the antioxidant can be equally distributed throughout or unequally distributed. For example, the antioxidant, such as that

located near the outer peripheral region of an endoprosthesis, can be distributed in a gradient manner along the radial direction of the endoprosthesis. Referring to FIG. 5, the antioxidant (shading) can increase in concentration toward an outer periphery 12 of an endoprosthesis 2, 2', 2''. Greater release of the antioxidant can be achieved during the early stages of the endoprosthesis lifetime following implantation. Referring to FIG. 6, the antioxidant (shading) can decrease in concentration toward an outer periphery 14 of an endoprosthesis 2, 2', 2''. The antioxidant release can increase during the endoprosthesis lifetime within a vessel. A decrease or increase in concentration of an antioxidant within an endoprosthesis can occur linearly, non-linearly (e.g., exponentially), and/or in a stepwise manner in order to tailor the release of the antioxidant. In some embodiments, an antioxidant layer includes one or more zones having an equal distribution of antioxidant throughout, and one or more zones having an unequal distribution of antioxidant, in any combination.

Referring to FIGS. 7-9, similarly, in embodiments in which the antioxidant layer is radially inward of the bioerodible layer, the antioxidant can be equally distributed throughout or unequally distributed. FIG. 7 shows an endoprosthesis 20 including an antioxidant layer 4''' located radially inwardly of a bioerodible layer 6'', for example, to avoid direct contact of the antioxidant with a vessel. The antioxidant can be uniformly dispersed within antioxidant layer 4'', which defines an inner circumferential region of endoprosthesis 20. In some embodiments, the antioxidant in antioxidant layer 4''' can be dispersed in a gradient manner along a radius of endoprosthesis 20 to tune the release of the antioxidant within a vessel. For example, as shown in FIG. 8, the antioxidant can increase in concentration radially outward, or as shown in FIG. 9, the antioxidant can decrease in concentration radially outward. A decrease or increase in concentration of the antioxidant within an endoprosthesis can occur linearly, exponentially, or in a stepwise manner in order to tailor the release of the antioxidant. In some embodiments, an antioxidant layer includes one or more zones having an equal distribution of antioxidant throughout, and one or more zones having an unequal distribution of antioxidant, in any combination.

Referring to FIGS. 10 and 11, the antioxidant layer be on selected portion(s) of the bioerodible layer, for example, to tune the release of antioxidant, to treat specific locations in a vessel, or to create a desirable degradation pattern. For example, FIG. 10 shows an endoprosthesis 22 having a bioerodible layer 4''', and an antioxidant layer 6''' including an



antioxidant 24 located in strips extending along the length of. As another example, FIG. 11 shows an endoprosthesis 26 having a bioerodible layer 4''''', and an antioxidant 28 applied as circular bands on the bioerodible layer. Referring to FIG. 12, an endoprosthesis 30 includes a series of generally circumferential interconnected struts 32, and an antioxidant 34 can be applied to selected struts to reduce the degradation rate of the struts to maintain structural features of the struts compared to struts not including the antioxidant. An antioxidant can have a patterned distribution on the bioerodible layer, and/or along the length of an endoprosthesis

Referring to FIG. 13, a method 100 of making an endoprosthesis as described herein is shown. Method 100 includes forming a bioerodible tube (step 102), forming a pre-endoprosthesis from the bioerodible tube (step 104), and applying one or more antioxidants to the pre-endoprosthesis (step 106) to form an endoprosthesis. In other embodiments, one or more antioxidants are applied to the bioerodible tube, and the tube with the applied antioxidant(s) is subsequently formed into an endoprosthesis.

The bioerodible tube can be formed (step 102) by manufacturing a tubular member including (e.g., is formed of) one or more bioerodible materials and capable of supporting a bodily lumen. For example, a mass of bioerodible material can be machined into a rod that is subsequently drilled to form the tubular member. As another example, a sheet of bioerodible material can be rolled to form a tubular member with overlapping portions, or opposing end portions of the rolled sheet can be joined (e.g., welded) together to form a tubular member. A bioerodible material can also be extruded to form a tubular member. The bioerodible or erodible material can be a substantially pure metallic element, or an alloy. The alloy can include metal and non-metal components, for example, the alloy can be a metallic alloy, a ceramic, or a metal matrix composite. Examples of metallic elements include iron and magnesium. Examples of alloys include iron alloys having, by weight, 88-99.8% iron, 0.1-7% chromium, 0-3.5% nickel, and less than 5% of other elements (e.g., magnesium and/or zinc); or 90-96% iron, 3-6% chromium and 0-3% nickel plus 0-5% other metals. Other examples of alloys include magnesium alloys, such as, by weight, 50-98% magnesium, 0-40% lithium, 0-5% iron and less than 5% other metals or rare earths; or 79-97% magnesium, 2-5% aluminum, 0-12% lithium and 1-4% rare earths (such as cerium, lanthanum, neodymium and/or praseodymium); or 85-91% magnesium, 6-12% lithium, 2% aluminum

and 1% rare earths; or 86-97% magnesium, 0-8% lithium, 2% -4% aluminum and 1-2% rare earths; or 8.5-9.5% aluminum, 0.15%-0.4% manganese, 0.45-0.9% zinc and the remainder magnesium; or 4.5-5.3% aluminum, 0.28%-0.5% manganese and the remainder magnesium; or 55-65% magnesium, 30-40% lithium and 0-5% other metals and/or rare earths.

5 Magnesium alloys are also available under the names AZ91D, AM50A, and AE42. Other erodible materials are described in Bolz, U.S. 6,287,332 (e.g., zinc-titanium alloy and sodium-magnesium alloys); Heublein, U.S. Patent Application 2002000406; and Park, *Science and Technology of Advanced Materials*, 2, 73-78 (2001), all of which are hereby incorporated by reference herein in their entirety. In particular, Park describes Mg-X-Ca  
10 alloys, e.g., Mg-Al-Si-Ca, Mg-Zn-Ca alloys. The bioerodible tube can include more than one bioerodible material, such as different bioerodible materials physically mixed together, multiple layers of different bioerodible materials, and/or multiple sections of different bioerodible materials along a direction (e.g., length) of the tube. In other embodiments, the bioerodible material is a bioerodible polymer.

15 As shown in FIG. 13, after the bioerodible tube is formed, the tube is formed into a pre-endoprosthesis (step 104). For examples, selected portions of the tube can be removed to form bands and connectors by laser cutting, as described in U.S. Patent No. 5,780,807, hereby incorporated by reference in its entirety. Other methods of removing portions of the tube can be used, such as mechanical machining (e.g., micro-machining, grit blasting or  
20 honing), electrical discharge machining (EDM), and photoetching (e.g., acid photoetching). The pre-endoprosthesis can be etched and/or electropolished to provide a selected finish. In certain embodiments, such as jelly-roll type endoprostheses, step 104 is omitted.

Prior to apply the antioxidant, selected surfaces (e.g., inner surface) or portions (e.g., portion between the end portions of the endoprosthesis) of the pre-endoprosthesis can be  
25 masked so that the antioxidant will not be applied to the masked surfaces or portions.

In some embodiments, prior to applying the antioxidant, pores are formed on/in the pre-endoprosthesis, the bioerodible tube, and/or a coating layer. Pores can be formed by a variety of methods (e.g., micro-arc surface modification, sol-gel templating process, plasma spraying, adding foaming structures into a melt or liquid metal, melting a powder compact  
30 containing a gas evolving element or a space holder material, incorporating a removable scaffold (e.g., polyurethane) in a metal powder/slurry prior to sintering, sintering hollow

spheres, sintering fibers, combustion synthesis, powder metallurgy, bonded fiber arrays, wire mesh constructions, vapor deposition, three-dimensional printing, and/or electrical discharge compaction). In some embodiments, pores can be formed by incorporating embedded microparticles and/or compounds (e.g., a salt) within the antioxidant layer (e.g., a polymerizable monomer, a polymer, a metal alloy), forming the antioxidant layer, and removing (e.g., dissolving, leaching, burning) the microparticles and/or compounds to form pores at locations where the microparticles and/or compounds were embedded. Removable (e.g., dissolvable) microparticles can be purchased, for example, from MicroParticles GmbH. In some embodiments, pores are formed by using a gas as a porogen, bonding fibers, and/or phase separation in materials such as polymers, metals, or metal alloys. Methods for forming porous structures are described, for example, in Ryan *et al.*, *Biomaterials*, 2006, 27, 2651; Liao *et al.*, *Journal of Biomedical Materials Research*, 2001, 59(4), 676; Mikos *et al.*, *Electronic Journal of Biotechnology*, 2000, 3(2), 1; Widmer *et al.*, *Biomaterials*, 1998, 19, 1945; and Gomes *et al.*, *Materials Science and Engineering C*, 2002, 20, 19.

Next, the antioxidant(s) can be applied to the pre-endoprosthesis (step 106) to form an endoprosthesis. The antioxidant and a polymer (e.g., polylactic acid (PLA), polylactic glycolic acid (PLGA), polyanhydrides (e.g., poly(ester anhydride)s, fatty acid-based polyanhydrides, amino acid-based polyanhydrides), polyesters, polyester-polyanhydride blends, polycarbonate-polyanhydride blends, and/or combinations thereof) can be dissolved in a solvent and applied to the pre-endoprosthesis, the antioxidant and the polymer can be blended together (e.g., in a manner that the antioxidant is mixed, embedded or encapsulated in a polymer matrix) and applied to the pre-endoprosthesis, and/or the antioxidant and the polymer can be formed into a composite in a solvent and applied to the pre-endoprosthesis. In some embodiments, the antioxidant layer is directly deposited onto an endoprosthesis (e.g., by electropolymerization). Methods for depositing an antioxidant is described, for example, in Andión *et al.*, *Corrosion Science.*, 2002, 44, 2805-2816. The antioxidant can be applied (e.g., adsorbed on the surfaces defining the pores, adsorbed on a substantially pore-free surface, or dispersed within the pores) directly to the pre-endoprosthesis using vapor phase adsorption, solution phase adsorption methods (e.g., solution impregnation). The antioxidant can also be incorporated with (e.g., encapsulated in) particles including a second, different bioerodible material than the bioerodible material in the pre-endoprosthesis, the

second bioerodible material with the antioxidant can be applied to the pre-endoprosthesis. The second bioerodible material can also be combined with the bioerodible material and co-extruded with a bioerodible material free of the second bioerodible material. In some embodiments, more than one method of applying an antioxidant to a pre-endoprosthesis can be used. As an example, a pre-endoprosthesis may be coated with an antioxidant in a polymer matrix, and impregnated with a bioerodible material-encapsulated antioxidant. Methods for incorporating one material in another are described, for example, in Jiang, S.B., *Materials Science and Engineering*, 2006, 418, 199.

In certain embodiments, the antioxidant can be applied to a pre-endoprosthesis in one layer, or in multiple layers (e.g., at least two layers, at least three layers, at least four layers, at least five layers) in order, for example, to provide greater control over the amount and variety of the antioxidant. For example, the layers can have different concentrations of one or more antioxidants (e.g., to provide a gradient or other profiles of antioxidants), and/or the layers can have different compositions of antioxidants. Within an antioxidant layer, the concentrations and/or compositions of the antioxidant can be the same or different to provide a selected antioxidant profile. For example, the end portions of the endoprosthesis can have a greater concentration of antioxidant than the intermediate portion of the endoprosthesis to provide reduced restenosis. The antioxidant layers can be applied the same way or in different ways. For example, a first, innermost antioxidant layer can be sorbed to a porous surface of the pre-endoprosthesis, and a second, outer antioxidant layer can include an antioxidant and a polymer that are applied to the first layer.

As indicated above, in some embodiments, the antioxidant(s) is applied to the bioerodible tube prior to forming the bioerodible tube into an endoprosthesis (if necessary). As a result, the endoprosthesis can have its outer and inner surfaces coated with the antioxidant(s), and the side surfaces of the endoprosthesis can be free of the antioxidant(s). Prior to applying the antioxidant(s), the inner surface or the outer surface of the bioerodible tube can be masked to apply the antioxidant(s) to only selected portion(s) of the tube.

The endoprosthesis can be made of a desired shape and size (e.g., coronary stents, aortic stents, peripheral vascular stents, gastrointestinal stents, urology stents, and neurology stents). Depending on the application, the endoprosthesis can have a diameter of between, for example, 1 mm to 46 mm. In certain embodiments, a coronary stent can have an

expanded diameter of from about 2 mm to about 6 mm. In some embodiments, a peripheral stent can have an expanded diameter of from about 5 mm to about 24 mm. In certain embodiments, a gastrointestinal and/or urology stent can have an expanded diameter of from about 6 mm to about 30 mm. In some embodiments, a neurology stent can have an expanded diameter of from about 1 mm to about 12 mm. An abdominal aortic aneurysm (AAA) stent and a thoracic aortic aneurysm (TAA) stent can have a diameter from about 20 mm to about 46 mm.

The endoprotheses described herein can be configured for non-vascular lumens. For example, they can be configured for use in the esophagus or the prostate. Other lumens include biliary lumens, hepatic lumens, pancreatic lumens, urethral lumens and ureteral lumens.

In use, the endoprosthesis can be used, e.g., delivered and expanded, using a catheter delivery system, such as a balloon catheter system. Catheter systems are described in, for example, Wang U.S. 5,195,969, Hamlin U.S. 5,270,086, and Raeder-Devens, U.S. 6,726,712. Endoprosthesis delivery, such as stent delivery, are also exemplified by the Radius® or Symbiot® systems, available from Boston Scientific Scimed, Maple Grove, MN.

The endoprotheses described herein can be a covered stent or a stent-graft. For example, the stent described herein can include and/or be attached to a biocompatible, non-porous or semi-porous polymer matrix including polytetrafluoroethylene (PTFE), expanded PTFE, polyethylene, urethane, or polypropylene.

The endoprotheses can further include a releasable therapeutic agent, drug, or a pharmaceutically active compound, such as described in U.S. Patent No. 5,674,242, U.S.S.N. 09/895,415, filed July 2, 2001, U.S.S.N. 11/111,509, filed April 21, 2005, and U.S.S.N. 10/232,265, filed August 30, 2002. The therapeutic agents, drugs, or pharmaceutically active compounds can include, for example, anti-thrombogenic agents, antioxidants, anti-inflammatory agents, anesthetic agents, anti-coagulants, and antibiotics. The therapeutic agent, drug, or a pharmaceutically active compound can be dispersed in a polymeric coating carried by the stent. The polymeric coating can include more than a single layer. For example, the coating can include two layers, three layers or more layers, e.g., five layers. The therapeutic agent can be a genetic therapeutic agent, a non-genetic therapeutic agent, or cells. Therapeutic agents can be used singularly, or in combination. Therapeutic agents can

be, for example, nonionic, or they may be anionic and/or cationic in nature. An example of a therapeutic agent is one that inhibits restenosis, such as paclitaxel. The therapeutic agent can also be used, e.g., to treat and/or inhibit pain, encrustation of the stent or sclerosing or necrosing of a treated lumen. Any of the above coatings and/or polymeric portions can be  
5 dyed or rendered radio-opaque.

In other embodiments, an endoprosthesis includes one or more filaments or wires including one or more bioerodible materials and one or more antioxidants applied to the bioerodible material(s) as described above. The filaments or wires can be knitted, woven, or braided to form an endoprosthesis. All the filaments or only selected filaments can include  
10 bioerodible material and the antioxidant. The bioerodible material and/or the antioxidant can be the same or different.

All references, such as patent applications, publications, and patents, referred to herein are incorporated by reference in their entirety.

Other embodiments are within the scope of the claims.

## WHAT IS CLAIMED IS:

1. An endoprosthesis, comprising:  
a member comprising a bioerodible material; and  
an antioxidant carried by the member.  
5
2. The endoprosthesis of claim 1, wherein the antioxidant is on a surface of the member.
3. The endoprosthesis of claim 1, including a carrier layer carrying the antioxidant.  
10
4. The endoprosthesis of claim 3, wherein the antioxidant is within a matrix or carrier material.
5. The endoprosthesis of claim 3, wherein the carrier includes pores.  
15
6. The endoprosthesis of claim 3, wherein the carrier is bioerodible.
7. The endoprosthesis of claim 3, wherein the carrier is non-bioerodible.
- 20 8. The endoprosthesis of claim 3, wherein the carrier is a metal or a polymer.
9. The endoprosthesis of claim 1, wherein the antioxidant is encapsulated by the bioerodible material.
- 25 10. The endoprosthesis of claim 5, wherein the antioxidant is in a layer having a thickness of from about 0.5  $\mu\text{m}$  to about 10  $\mu\text{m}$ .
11. The endoprosthesis of claim 1, wherein the antioxidant comprises a phenol.
- 30 12. The endoprosthesis of claim 1, wherein the member comprises a tubular member constructed to maintain patency of a body vessel.

13. The endoprosthesis of claim 1, wherein the bioerodible material is iron or magnesium.
- 5 14. The endoprosthesis of claim 1, further comprising a drug carried by the member.
15. The endoprosthesis of claim 1, in the form of a stent.
- 10 16. A method of making the endoprosthesis of claim 1, the method comprising incorporating a bioerodible material with an antioxidant to form at least a portion of the endoprosthesis.



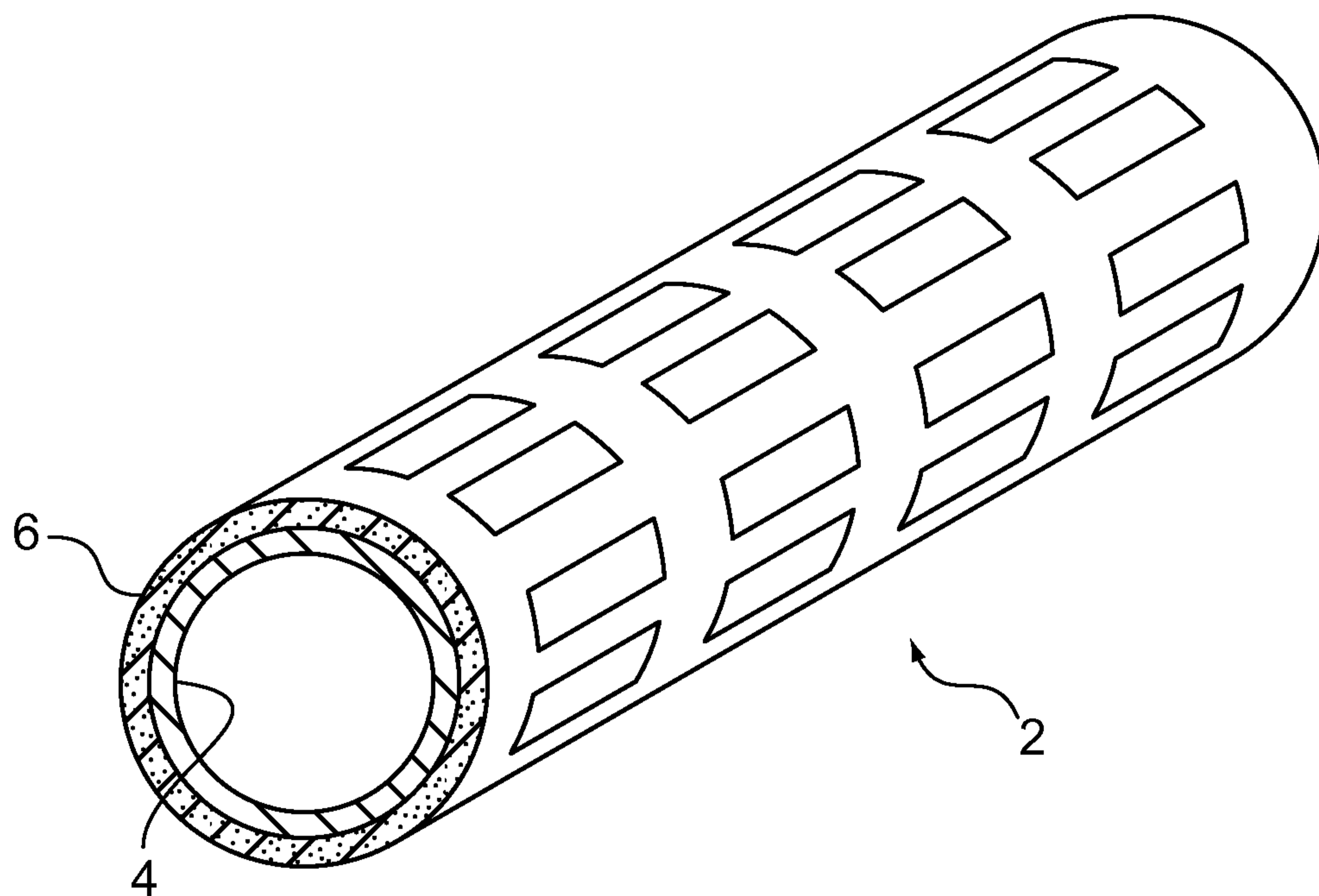

FIG. 1A

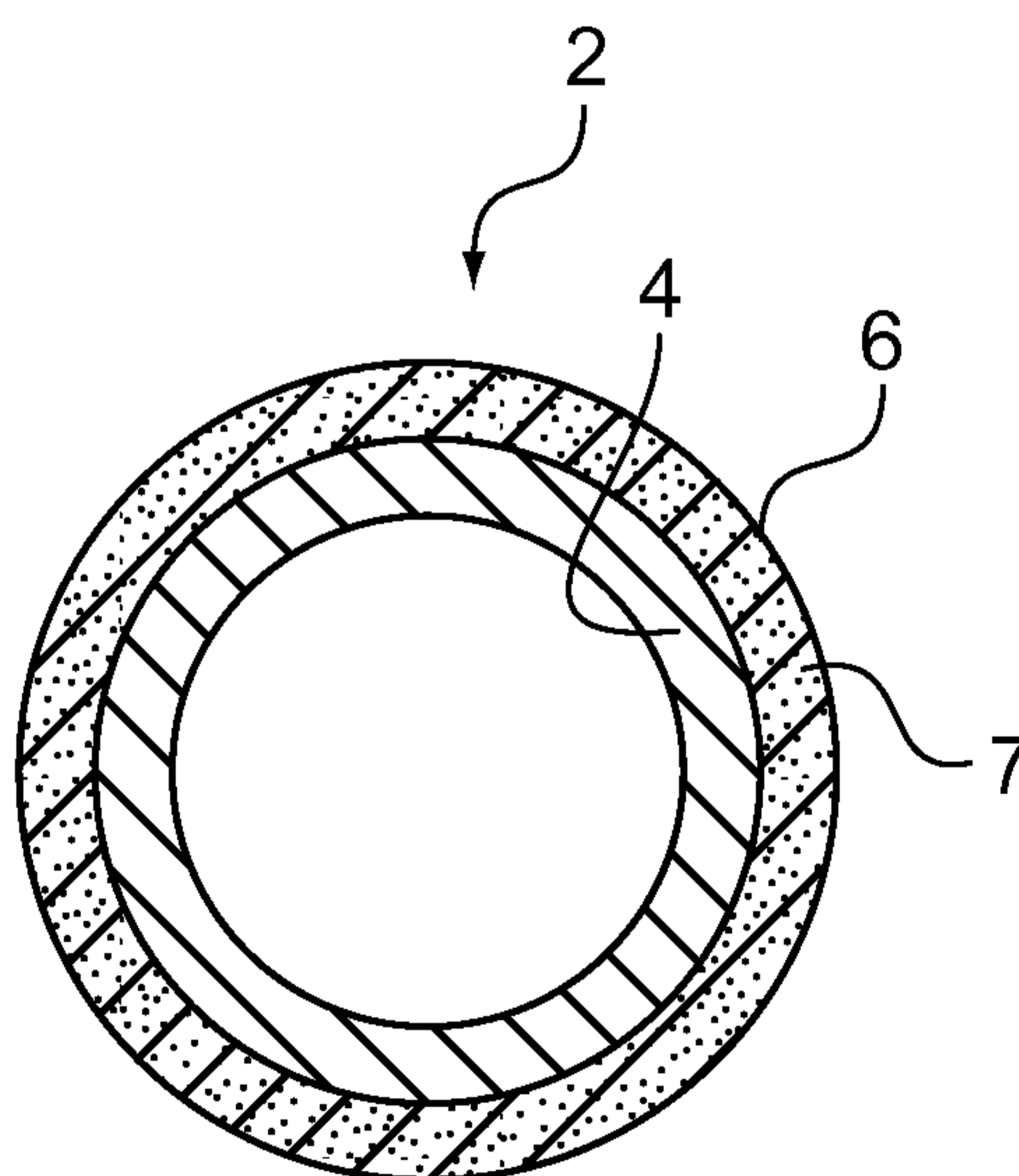

FIG. 1B

2/7

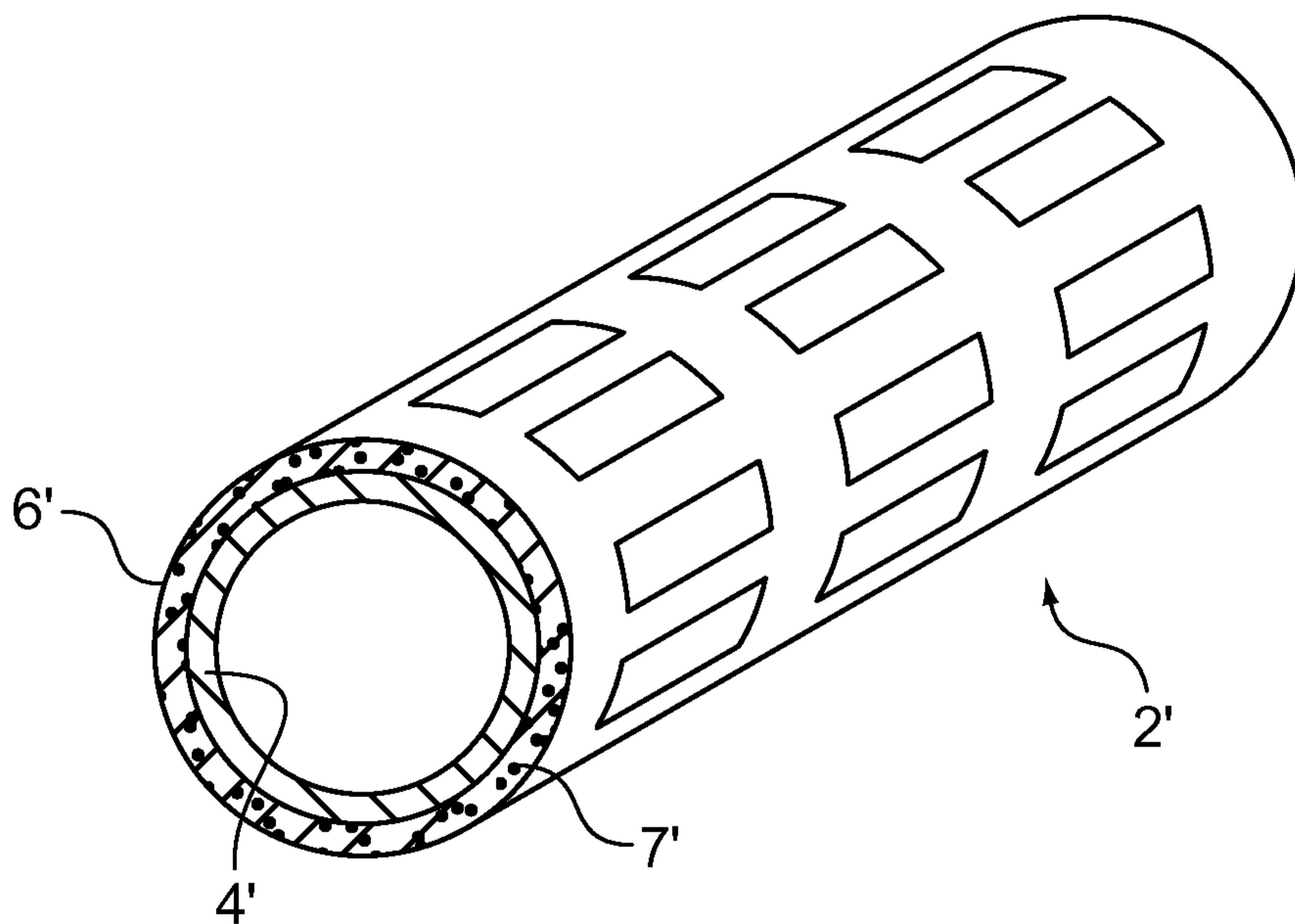

FIG. 2A

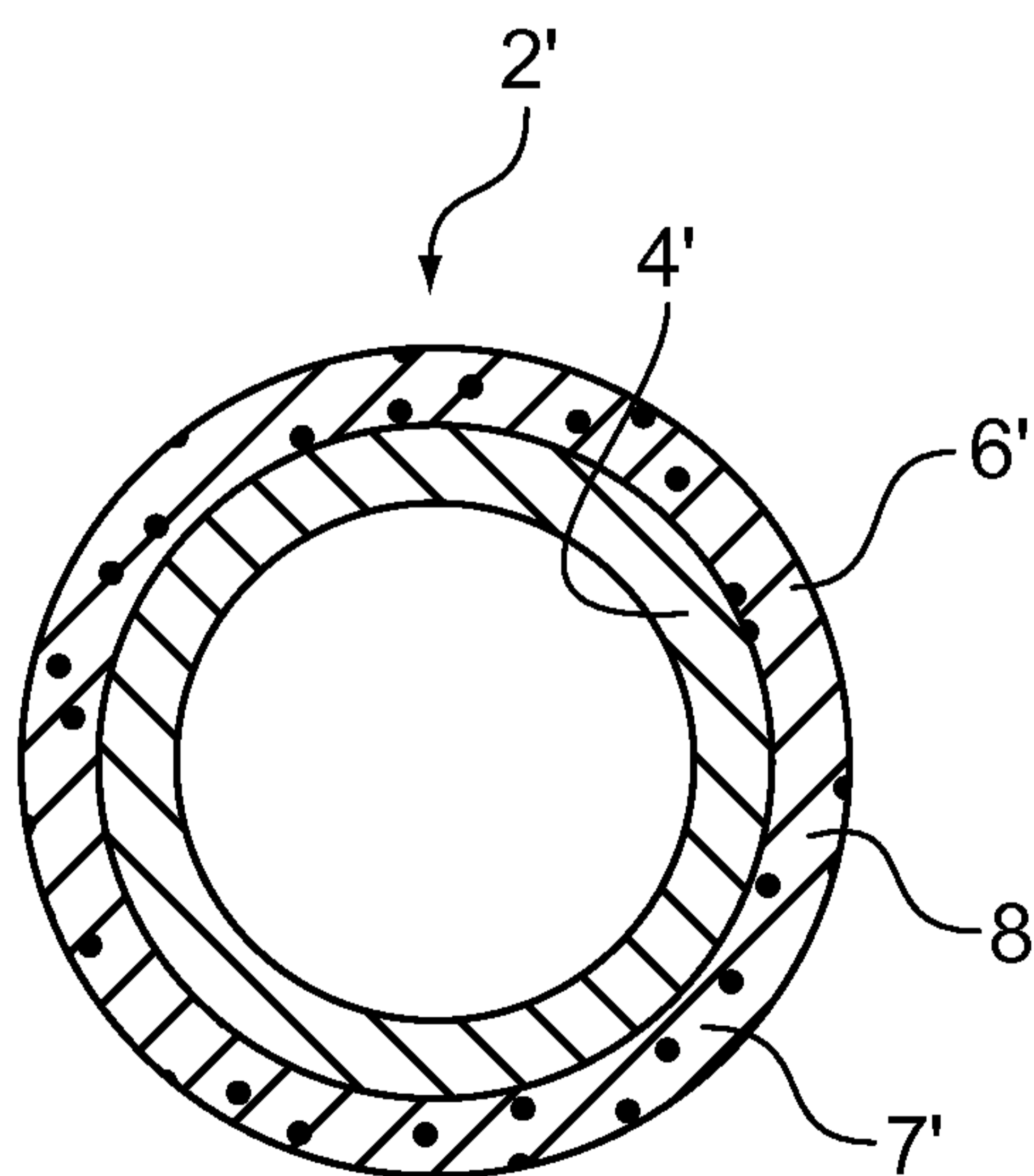

FIG. 2B

3/7

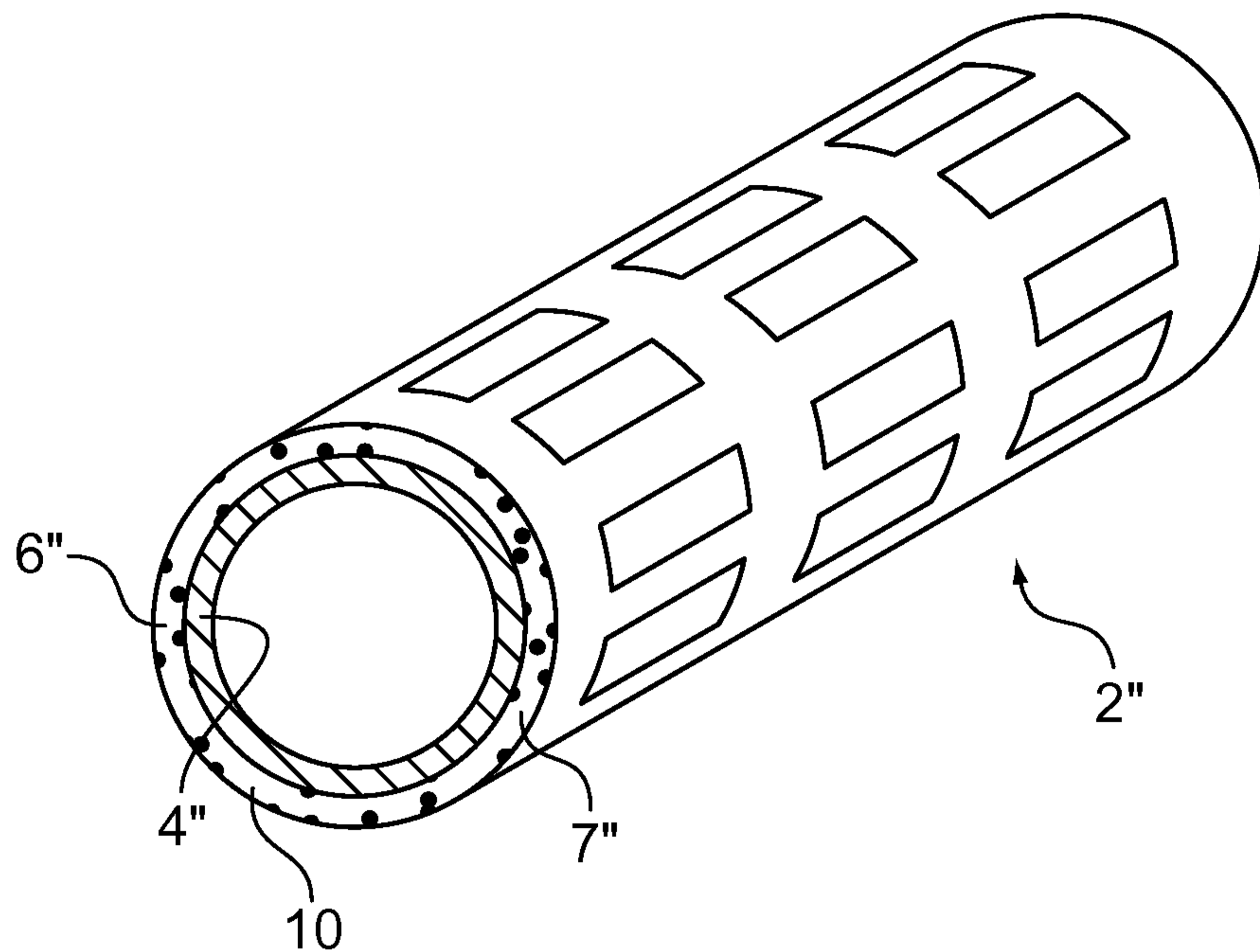

FIG. 3A

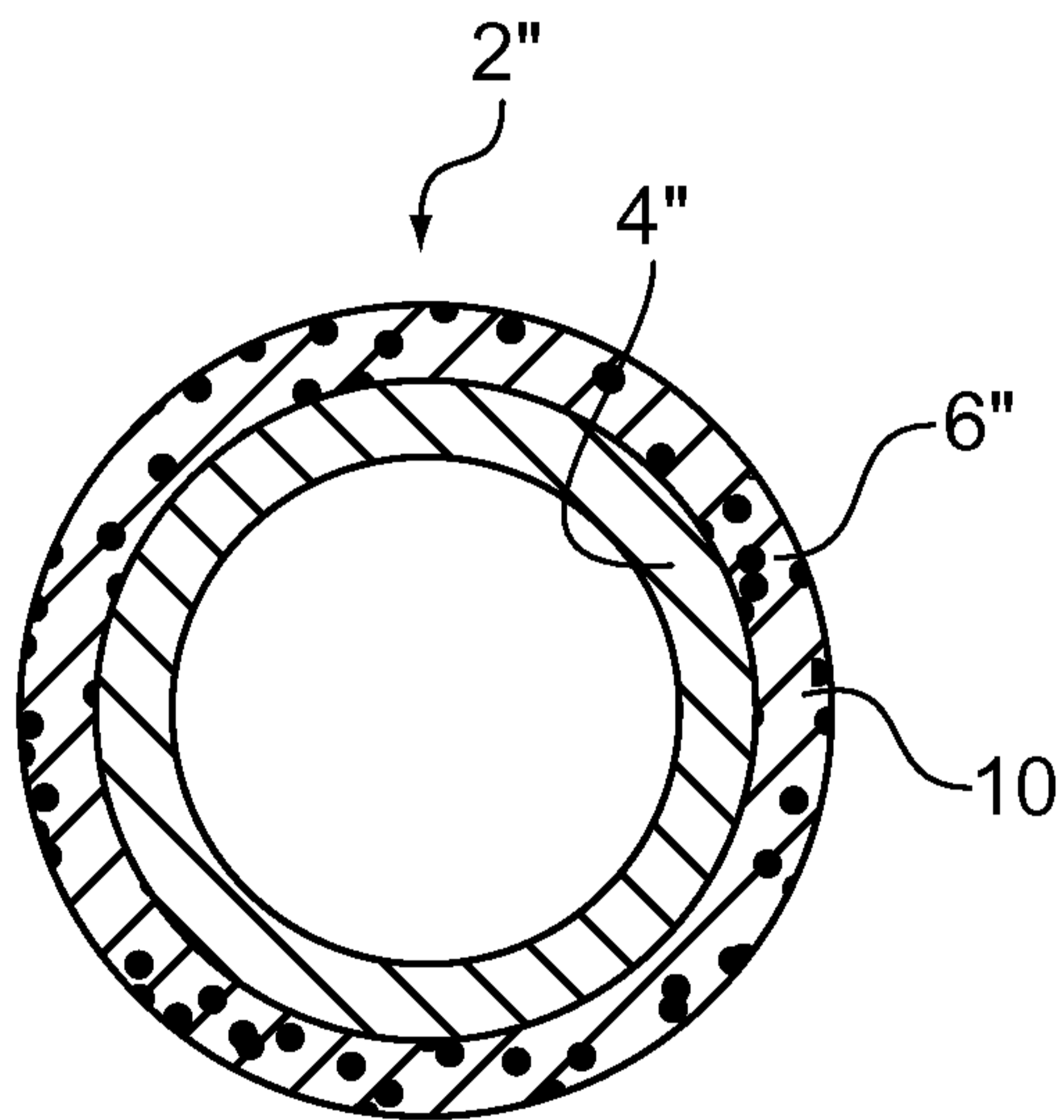

FIG. 3B

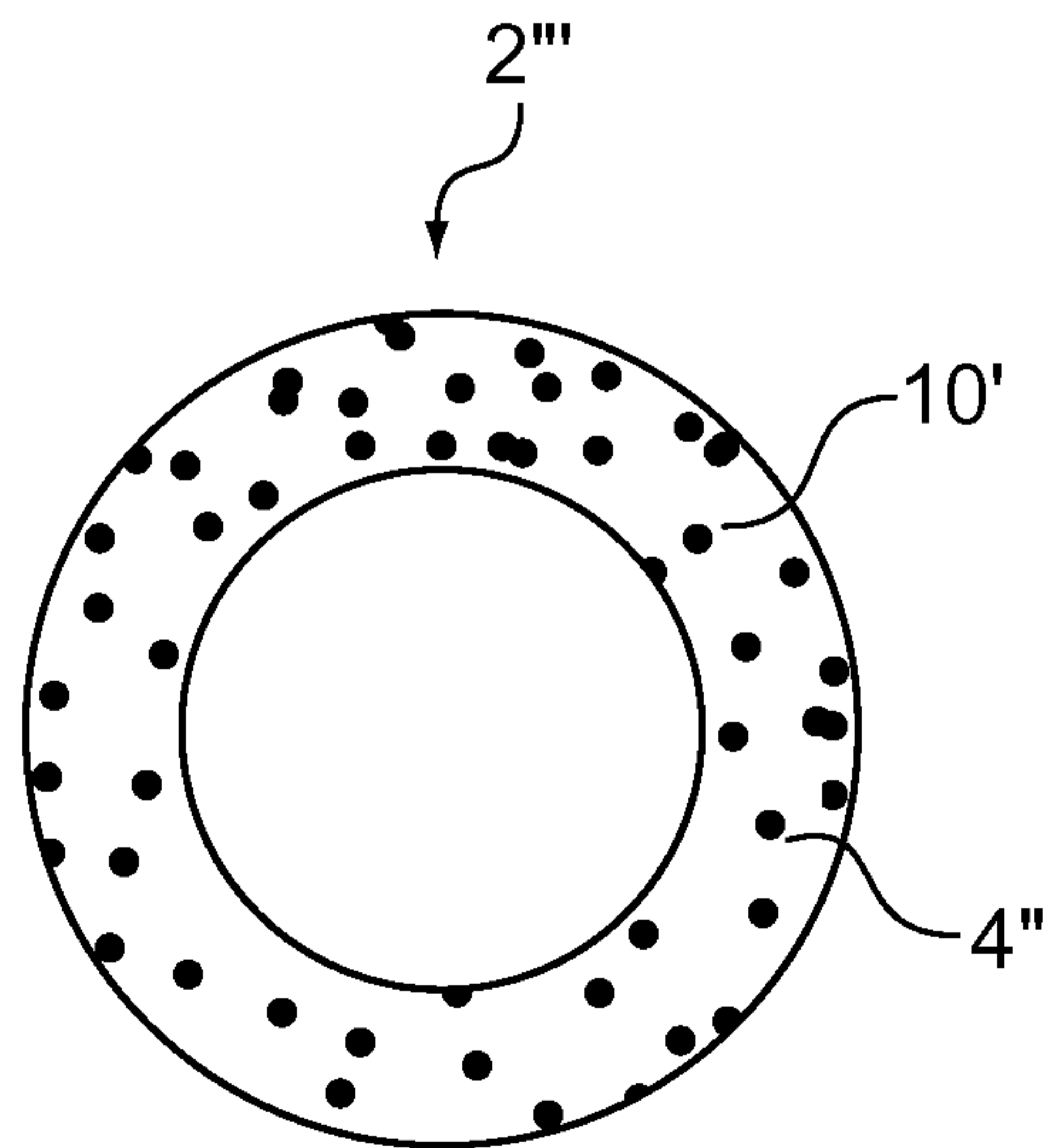

FIG. 3C

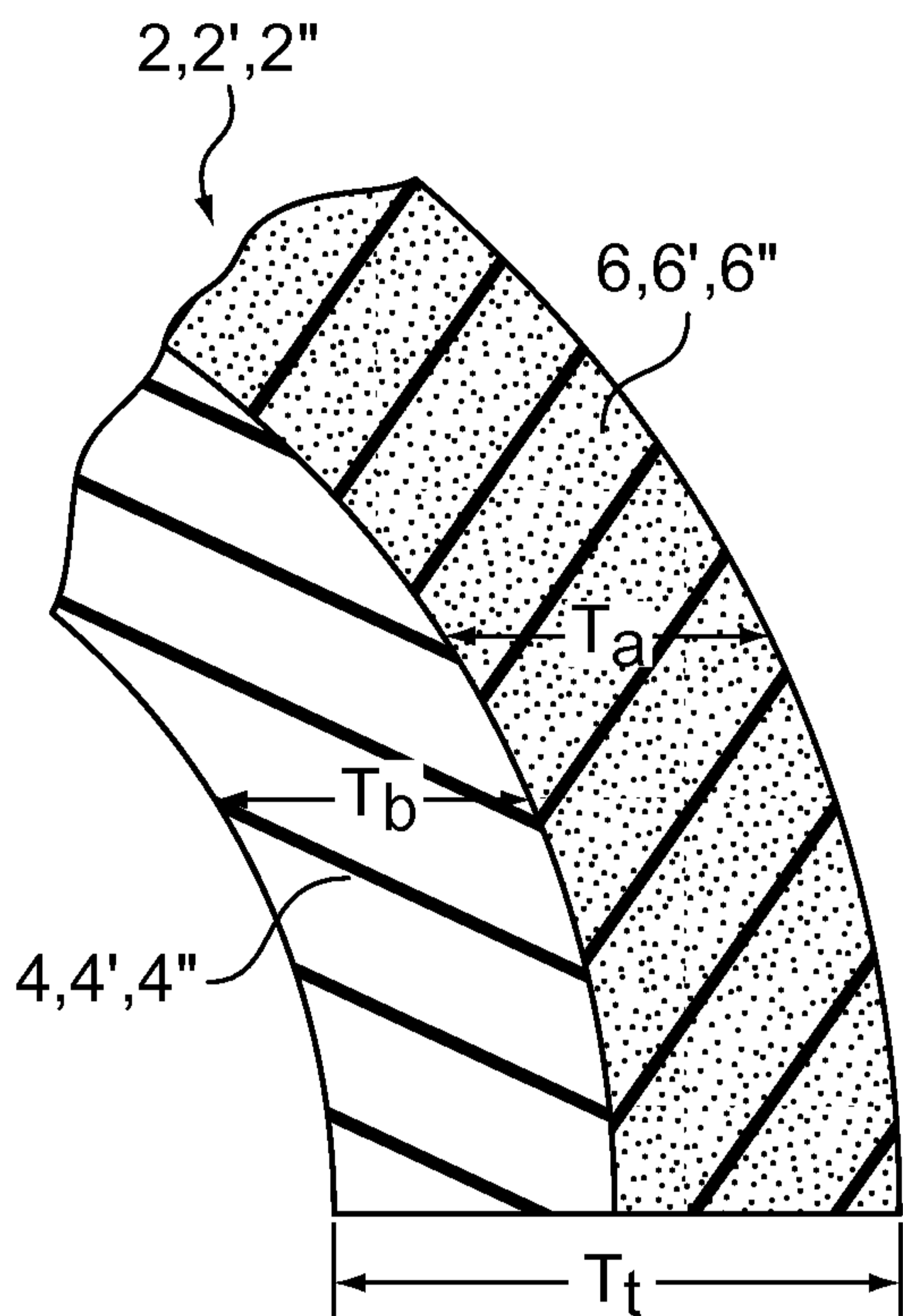

FIG. 4

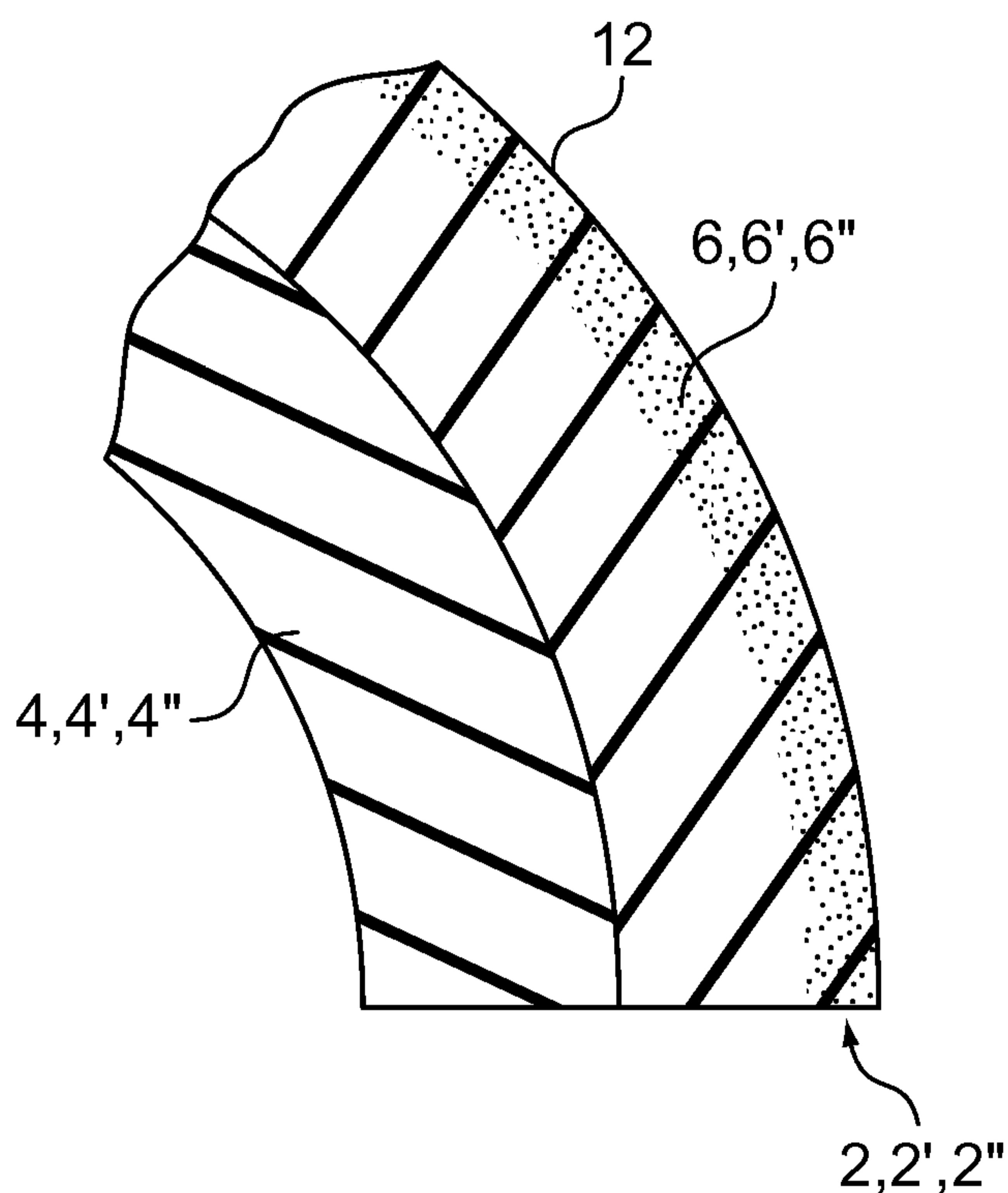

FIG. 5

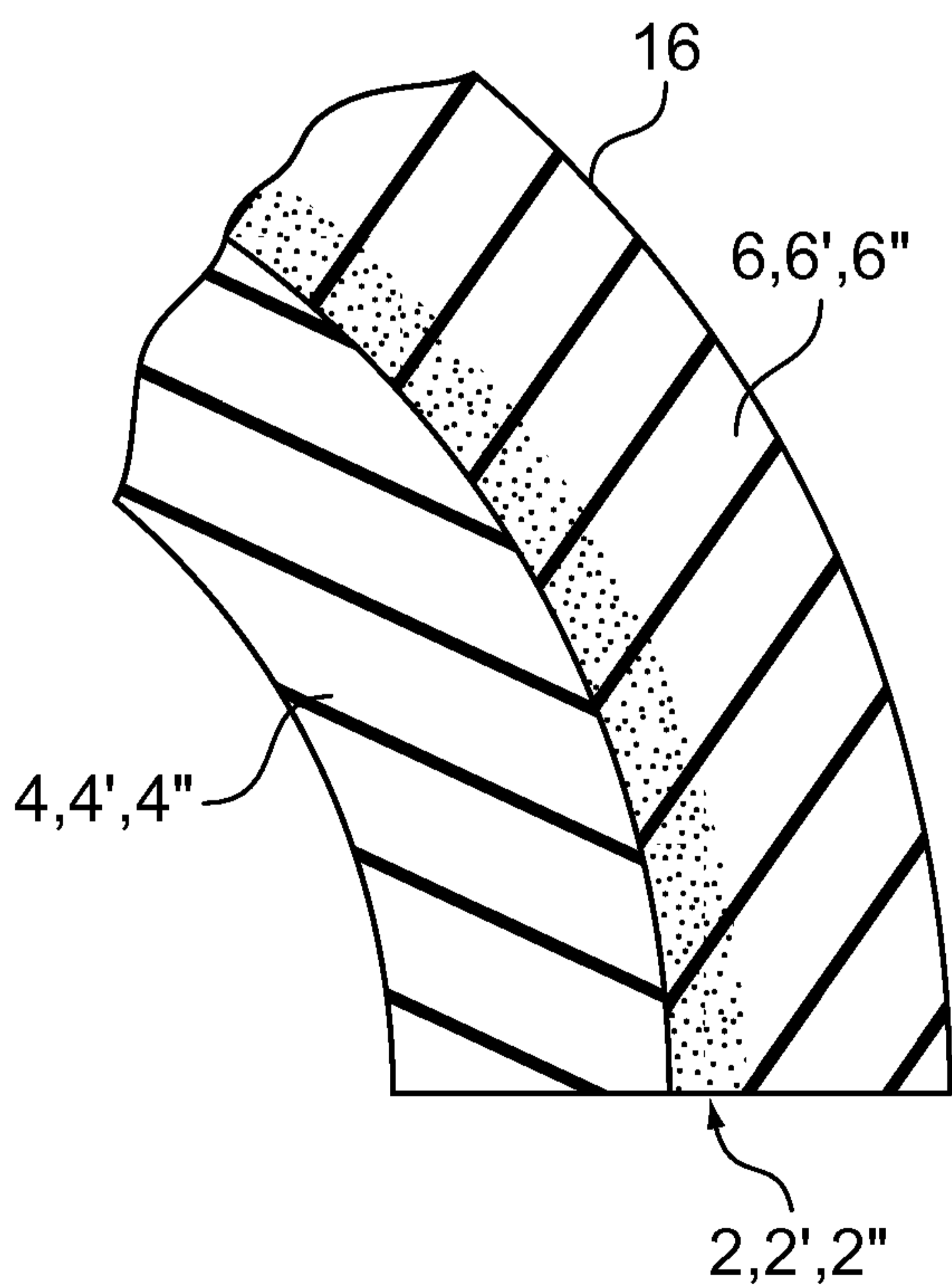

FIG. 6

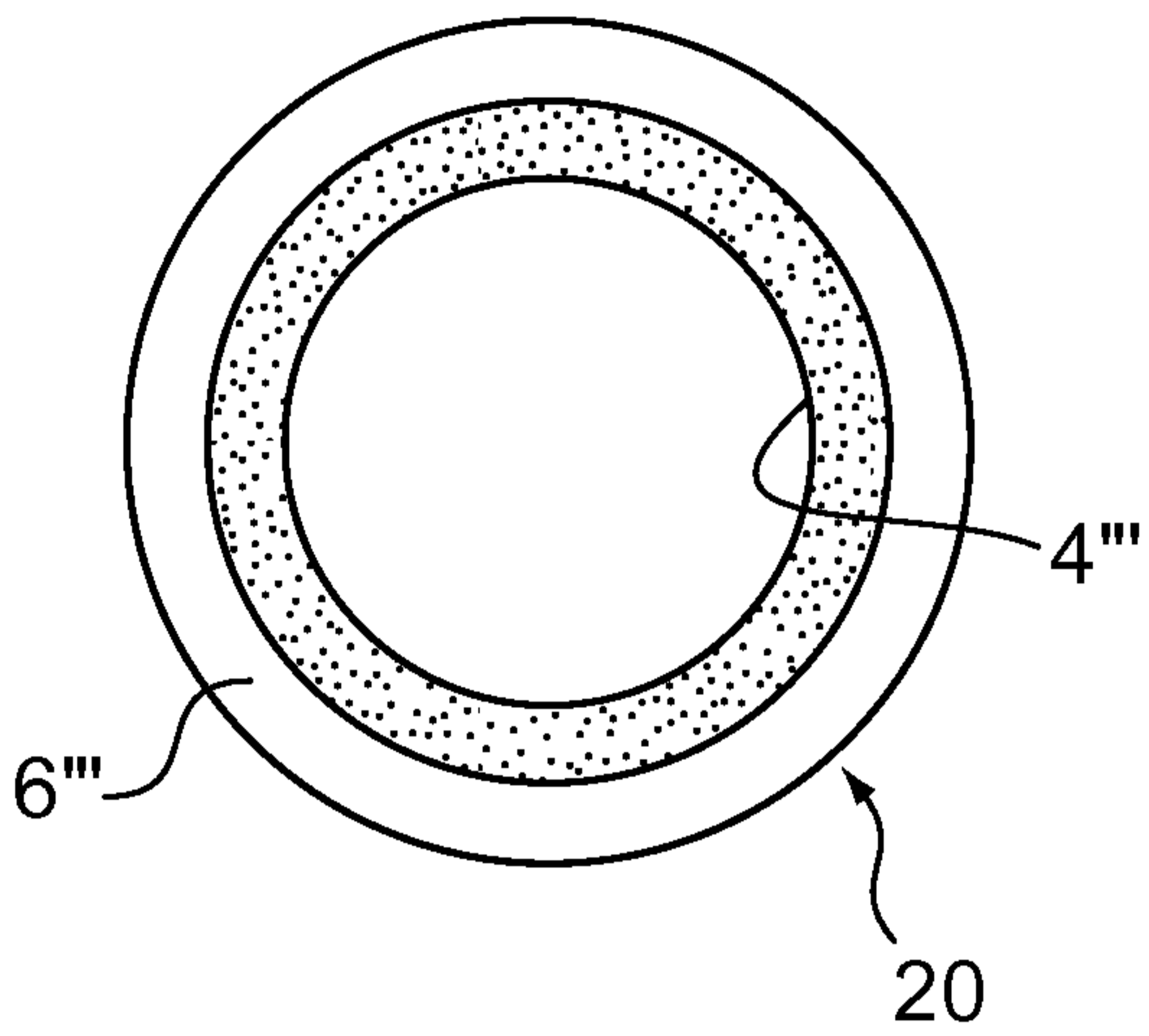

FIG. 7

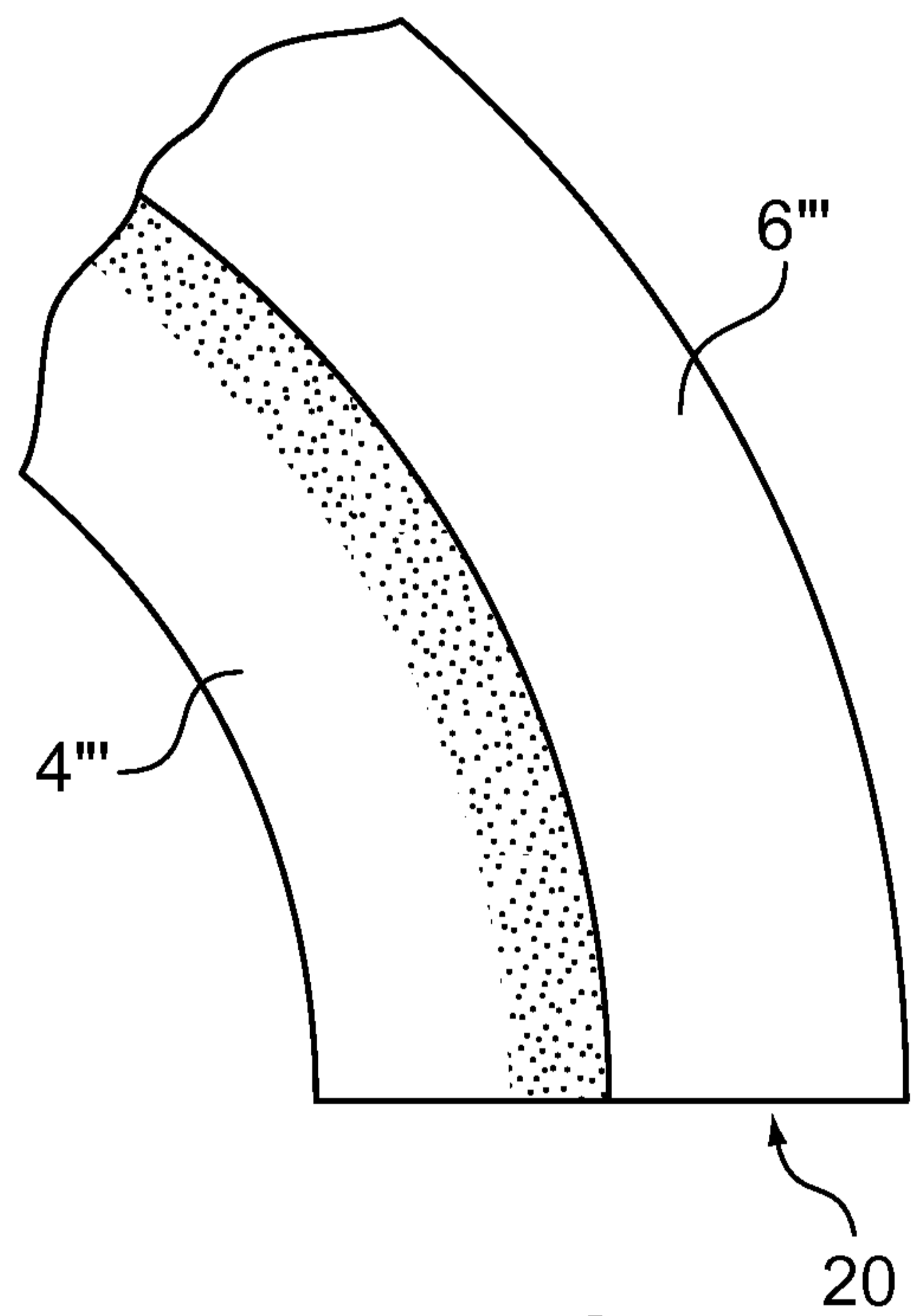

FIG. 8

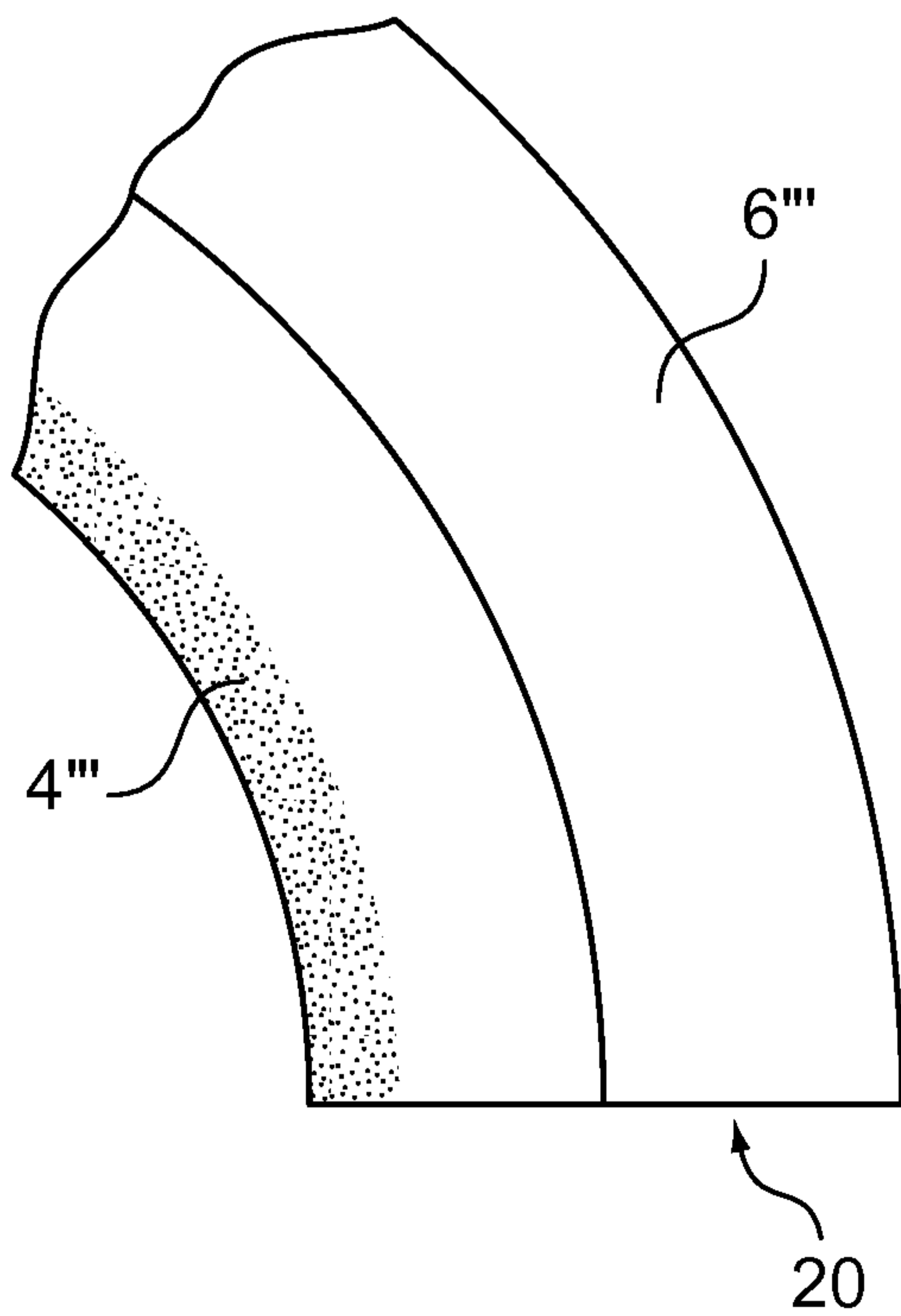

FIG. 9

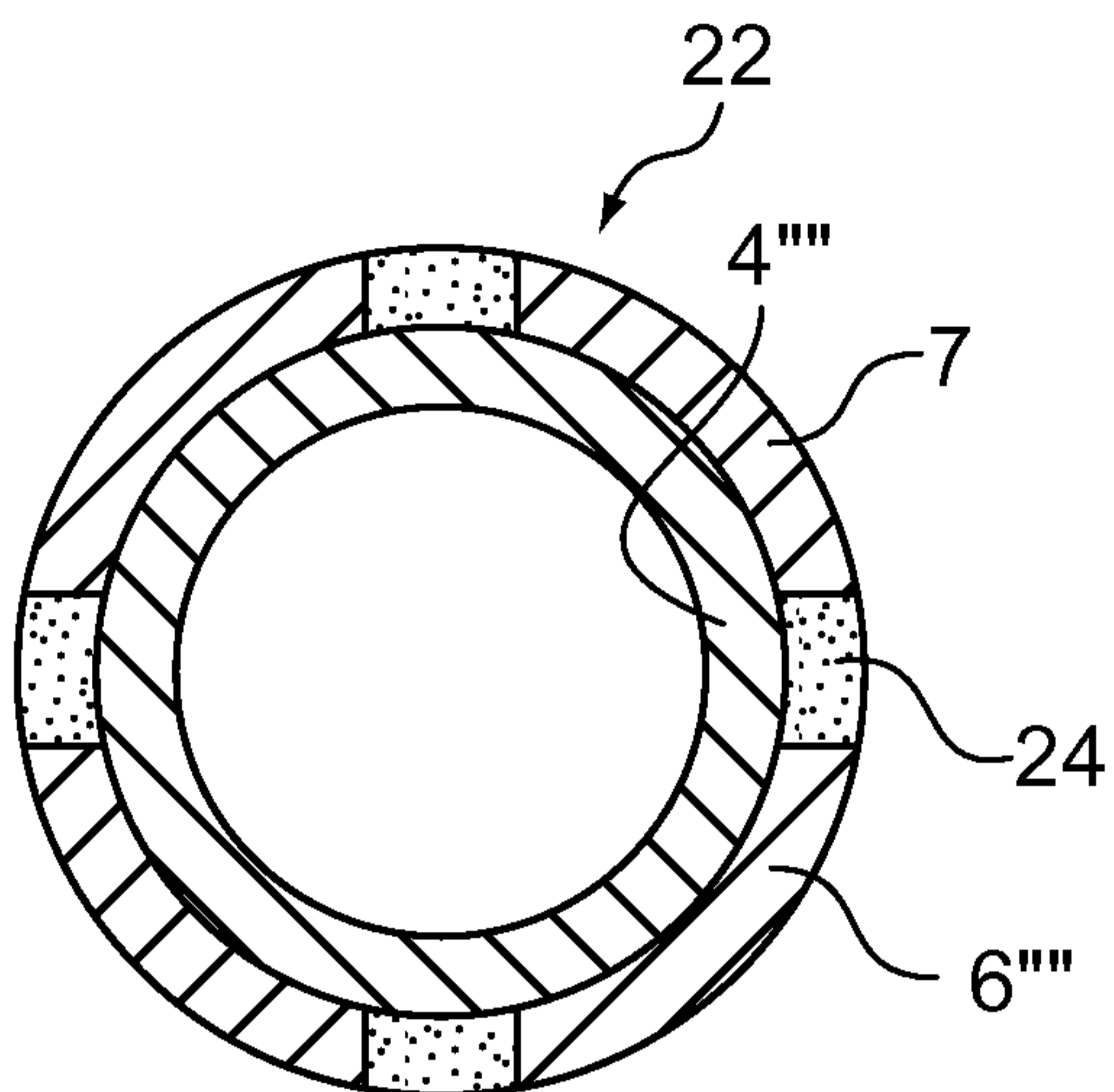

FIG. 10

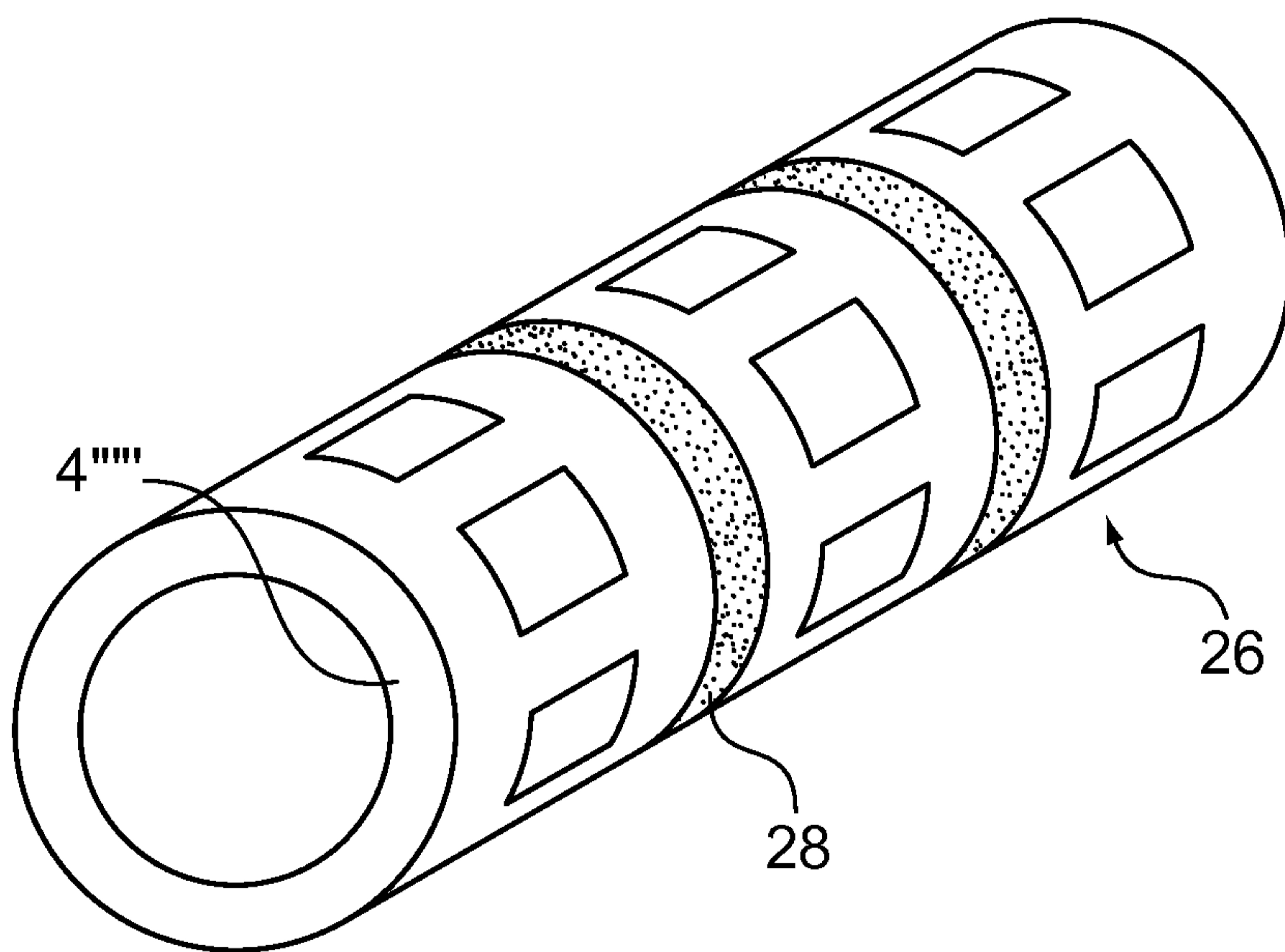

FIG. 11

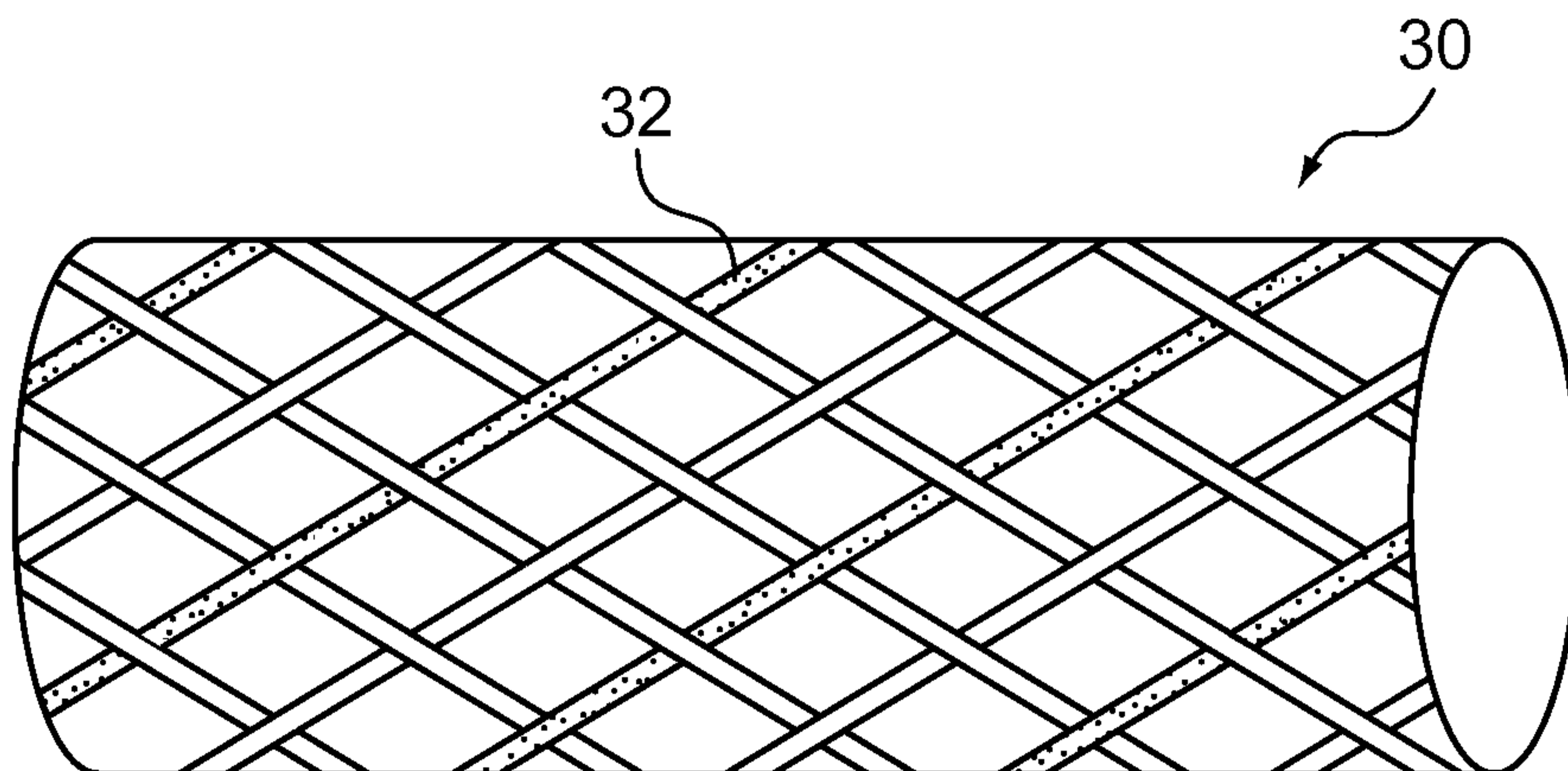

FIG. 12

7/7

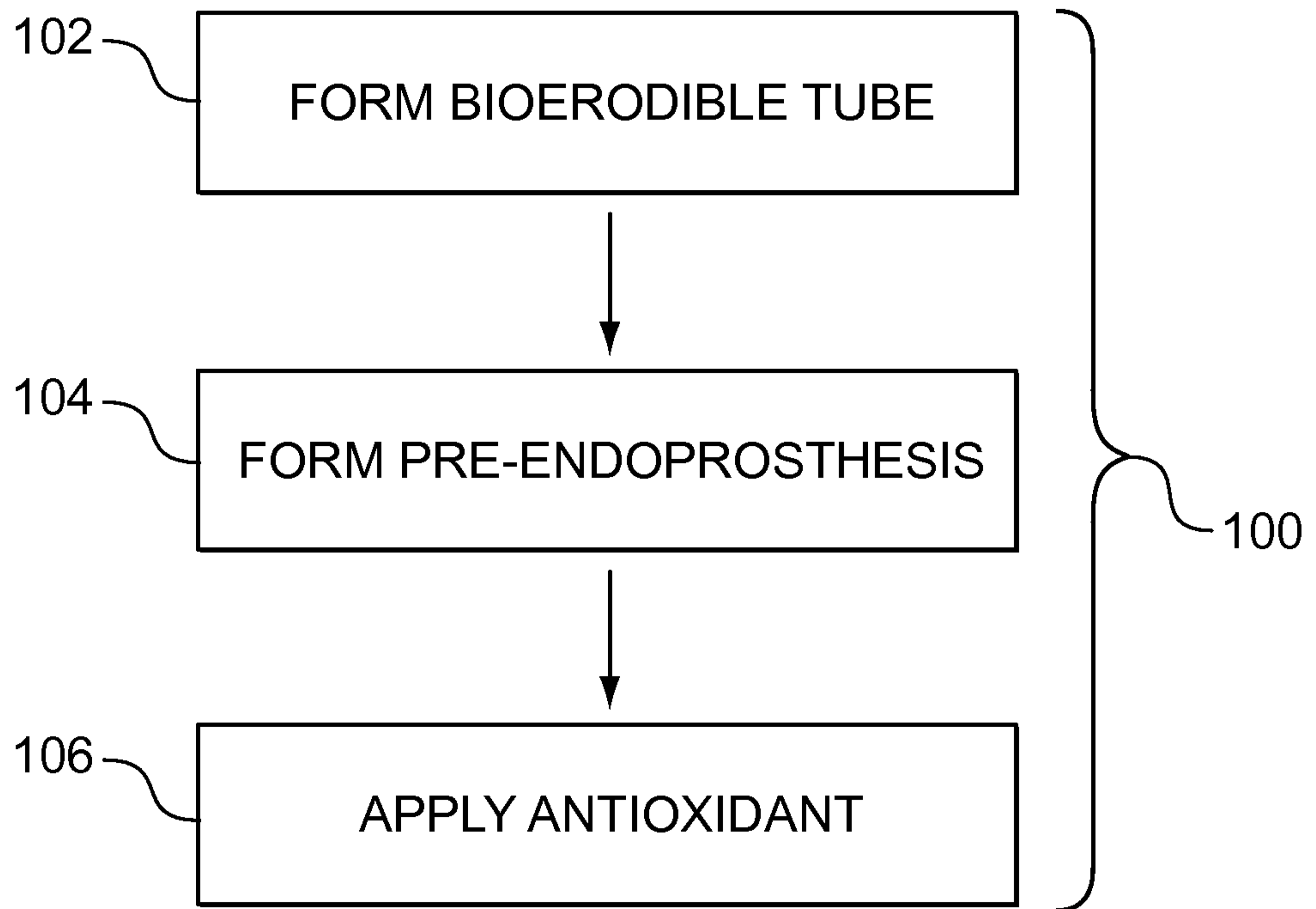

FIG. 13

