



(43) International Publication Date
20 December 2012 (20.12.2012)

(51) International Patent Classification:

A61C 5/04 (2006.01) B05C 17/01 (2006.01)
A61M 5/315 (2006.01)

(21) International Application Number:

PCT/AU2012/000683

(22) International Filing Date:

14 June 2012 (14.06.2012)

(25) Filing Language:

English

(26) Publication Language:

English

(30) Priority Data:

2011902376 17 June 2011 (17.06.2011) AU

(71) Applicant (for all designated States except US): **SDI LIMITED** [AU/AU]; PO Box 314, Bayswater, Victoria 3153 (AU).

(72) Inventors; and

(75) Inventors/Applicants (for US only): **CHEETHAM, Joshua James** [AU/AU]; 23 Lewisham Road, Windsor, Victoria 3181 (AU). **FARRAR, Paul James**; 20 Mersey Street, Box Hill North, Victoria 3129 (AU).

(74) Agent: **LORD, Kelvin Ernest**; Lord and Company, PO Box 530, West Perth, Western Australia 6872 (AU).

(81) Designated States (unless otherwise indicated, for every kind of national protection available): AE, AG, AL, AM, AO, AT, AU, AZ, BA, BB, BG, BH, BR, BW, BY, BZ, CA, CH, CL, CN, CO, CR, CU, CZ, DE, DK, DM, DO, DZ, EC, EE, EG, ES, FI, GB, GD, GE, GH, GM, GT, HN, HR, HU, ID, IL, IN, IS, JP, KE, KG, KM, KN, KP, KR, KZ, LA, LC, LK, LR, LS, LT, LU, LY, MA, MD, ME, MG, MK, MN, MW, MX, MY, MZ, NA, NG, NI, NO, NZ, OM, PE, PG, PH, PL, PT, QA, RO, RS, RU, RW, SC, SD, SE, SG, SK, SL, SM, ST, SV, SY, TH, TJ, TM, TN, TR, TT, TZ, UA, UG, US, UZ, VC, VN, ZA, ZM, ZW.

(84) Designated States (unless otherwise indicated, for every kind of regional protection available): ARIPO (BW, GH, GM, KE, LR, LS, MW, MZ, NA, RW, SD, SL, SZ, TZ, UG, ZM, ZW), Eurasian (AM, AZ, BY, KG, KZ, RU, TJ, TM), European (AL, AT, BE, BG, CH, CY, CZ, DE, DK, EE, ES, FI, FR, GB, GR, HR, HU, IE, IS, IT, LT, LU, LV, MC, MK, MT, NL, NO, PL, PT, RO, RS, SE, SI, SK, SM, TR), OAPI (BF, BJ, CF, CG, CI, CM, GA, GN, GQ, GW, ML, MR, NE, SN, TD, TG).

Published:

— with international search report (Art. 21(3))

(54) Title: DENTAL SYRINGE

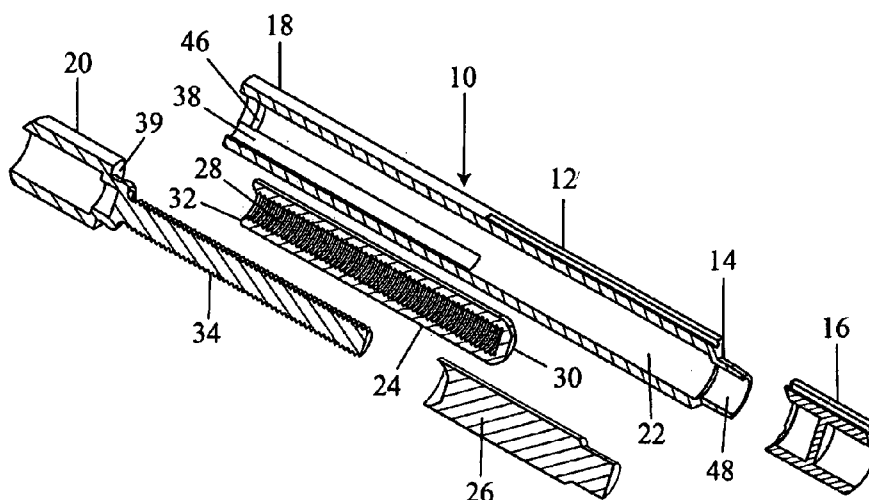

Fig 3a

(57) Abstract: A dental syringe (10) has a hollow elongated body (12) containing dental material (26). The body (12) has a removable end cap (16) and an axially rotatable member (20). The axially rotatable member (20) is attached to an externally threaded rod (34). The body (12) contains a non-rotatable piston (24) having a closed end (30) and an opposed open end (32). The piston (24) is inserted into the body (12) with the closed end (30) foremost. The piston (24) further comprises an axially extending recess (28) which is internally threaded. The threaded rod (34) is threadedly engaged with the recess (28). The axially rotatable member (20) may be rotated so as to cause the leading end (30) of the piston (24) to dispense dental material through the hollow body (12) after removal of the end cap (16).



WO 2012/171063 A1

TITLE

“DENTAL SYRINGE”

5.

FIELD OF THE INVENTION

The present invention relates to a dental syringe

SUMMARY OF THE INVENTION

10 In accordance with one aspect of the present invention there is provided a dental syringe characterized by comprising an outer body having a first end and a second outer end, the outer body containing an elongated hollow section having mounted therein a non-axially rotatable elongated piston, an axially rotatable member being mounted at the first end of the hollow section, the piston containing an axially extending elongated recess which is
15 internally threaded and having a closed end and an opposed open end, an externally threaded rod being connected to the axially rotatable member and being threadedly engaged with the recess contained in the piston, the arrangement being such that axial rotation of the rotatable member is able to cause the piston to move into the hollow section such that dental material contained in the hollow section between the piston and
20 the second end is dispensed from the second outlet end of the outer body.

DESCRIPTION OF THE DRAWINGS

The present invention will now be described, by way of example, with reference to the
25 accompanying drawings, in which:

Figure 1a is a perspective view of a dental syringe in accordance with the present invention;

Figure 1b is a view similar to Figure 1a with a cap removed;

Figure 2 is a perspective view of the syringe of Figures 1a and 1b in disassembled condition;

Figure 3a is a longitudinal sectional exploded view similar to Figure 2 of the dental syringe of Figures 1 and 2;

Figure 3b is a longitudinal assembled sectional view of the dental syringe of Figure 3a;

Figure 3c is a view similar to Figure 3b showing the dental syringe in activated condition.

DETAILED DESCRIPTION OF THE INVENTION

10

In Figures 1a and 1b and 2 of the accompanying drawings there is shown a dental syringe 10 for dispensing dental material comprising an elongated body 12. The elongated body 12 has a first outlet end 14 having mounted thereto a removable end cap 16 and a second end 18 having mounted thereto an axially rotatable member 20.

15

The elongated body 12 contains an elongated hollow section 22 best seen in Figure 3a, in which is mounted a non-axially rotatable elongated piston 24. During assembly the hollow section 22 is partially filled with dental material 26 at the outlet end 14 thereof adjacent the end cap 16. The piston 24 is then inserted into the hollow section 22 as shown in Figure 3b abutting the dental material 26.

20

As can be seen in Figure 3a the piston 24 contains an axially extending recess 28 which is internally threaded. The piston 24 also has a foremost closed end 30 and a trailing opposed open end 32.

The apparatus 10 further comprises an externally threaded rod 34 which is connected to the rotatable member 20.

5 The piston 24 contains one or more external raised sections 36 (see Figure 2) which engage with an elongated internal recess 38 in the body 12 (see Figure 3a).

The externally threaded rod 34 is arranged to be threadedly engaged with the internally threaded recess 28 of the piston 24.

10

Subsequent to insertion of the piston 24 into the body 12, the threaded rod 34 is threadedly engaged with the piston 24. The rod 34 is rotated by rotation of the rotatable member 20 until an inner end 39 of rotatable member 20 engages with the end 18 of the body 12. In this position, as shown in Figure 3b, the inner end 30 of the piston 24 is in engagement with the dental material 26. Further, it can be seen that there is an annular gap 40 between the open end 32 of the piston 24 and the end 18 of the body 12.

Further, it can be seen in Figure 2 that the rotatable member 20 has a ring 42 mounted near the inner end 39 thereof adjacent to the outer body 12. The ring 42 engages with the end 18 of the outer body 12 in the position shown in Figure 3b so as to retain the rotatable member 20 in position. In fact, the ring 42 is shaped to engage with an internal circumferential groove 46 within the end 18 of the outer body 12 as shown in Figures 3a and 3b.

It can also be seen that the end 14 of the body 12 has an outlet portion 48 of reduced internal cross section compared to the remainder of the hollow section 22 of the body 12.

In use, the rotatable member 20 is axially rotated as the inner end 39 engages with the end
5 18 of the body 12.

Subsequently the rotatable member 20 may be rotated so as to cause the piston 24 to move further into the body 12 with the closed end 30 leading or to move towards the end 18 of the body 12 with the open end 32 leading. This is achieved by variation of the
10 direction of rotation of the member 20 and the threaded engagement of the rod 34 with the recess 28.

To eject the dental material from the syringe 10, the removable end cap 16 has to be removed. Then the piston 24 is urged towards the end 14 by the above described rotation
15 of the rod 34. As shown in Figure 3c this causes the dental material 26 to be dispensed through the outlet 48. The dental material 26 is in this way made available for use by a dentist.

The outlet 48 could alternatively have an outlet of the same size as the hollow section 22.
20 The syringe 10 shown in the drawings is not circular in external shape but it could conveniently be made in a circular or a square shape if desired. Further, as shown in Figure 3, the closed end 30 of the piston 24 could be shaped such that it replicates the internal shape of the outlet 48, permitting the entire quantity of the dental material 26 to be dispensed.

Modifications and variations as would be apparent to a skilled addressee are deemed to be within the scope of the present invention.

CLAIMS

1. A dental syringe characterised by comprising an outer body having a first end and a second outer end, the outer body containing an elongated hollow section having
5 mounted therein a non-axially rotatable elongated piston, an axially rotatable member being mounted at the first end of the hollow section, the piston containing an axially extending elongated recess which is internally threaded and having a closed end and an opposed open end, an externally threaded rod being connected to the axially rotatable member and being threadedly engaged with the
10 recess contained in the piston, the arrangement being such that axial rotation of the rotatable member is able to cause the piston to move into the hollow section such that dental material contained in the hollow section between the piston and the second end is dispensed from the second outlet end of the outer body.
- 15 2. A dental syringe according to claim 1, characterised in that the piston is shaped to engage with the body to inhibit axial rotation of the piston.
3. A dental syringe according to claim 2, characterised in that the piston has at least one raised section arranged to engage with a corresponding internal elongated
20 recess in the body.
4. A dental syringe according to any one of the preceding claims, characterised in that the axially rotatable member is shaped to engage with the first end of the hollow section.

5. A dental syringe according to claim 4, characterised in that the axially rotatable member has a ring mounted thereto adjacent the outer body.

5 6. A dental syringe according to claim 5, characterised in that the outer body has an internal circumferential groove adjacent the first end thereof, the groove being arranged to engage with the ring member of the axially rotatable member.

10 7. A dental syringe according to any one of the preceding claims, characterised in that the second outlet end has an outlet portion of reduced internal cross sectional dimension.

15 8. A dental syringe according to any one of the preceding claims, characterised in that second outlet end is provided with a removable end cap.

9. A dental syringe according to any one of the preceding claims, characterised in that there is an annular gap between the open end of the piston and the first end of the outer body when the axially rotatable member is engaged with the first end of the hollow section.

20 10. A dental syringe according to any one of the preceding claims, characterised in that the syringe contains dental material.

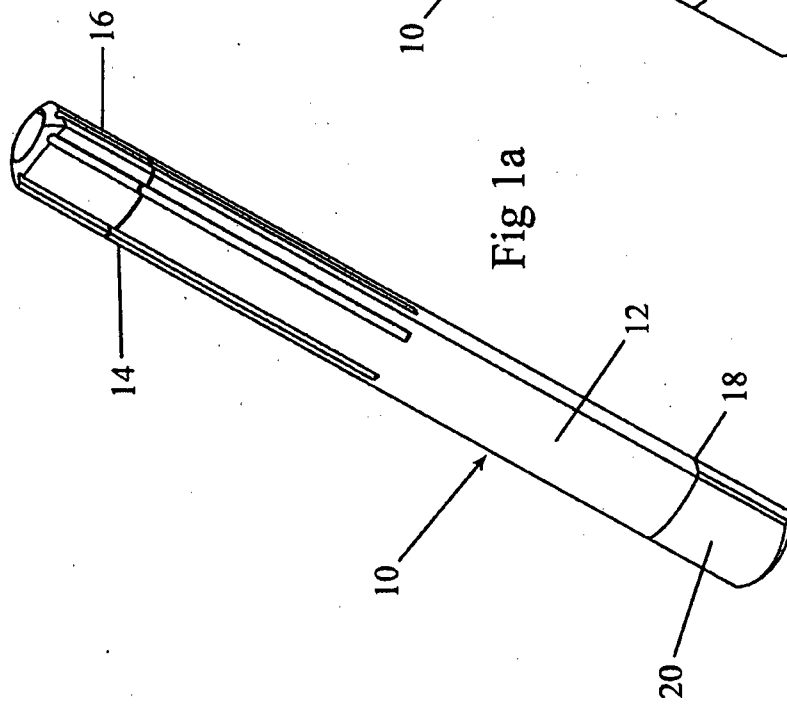
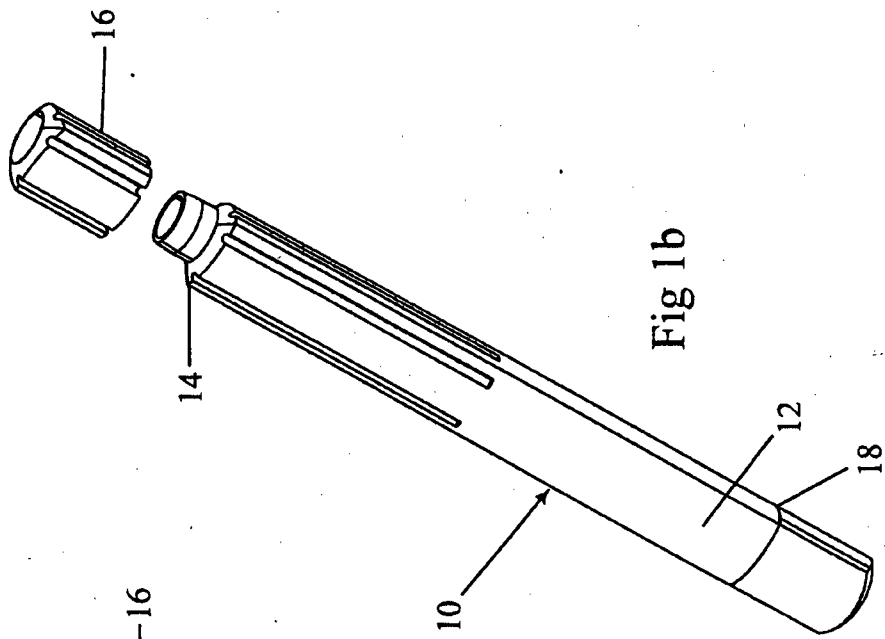

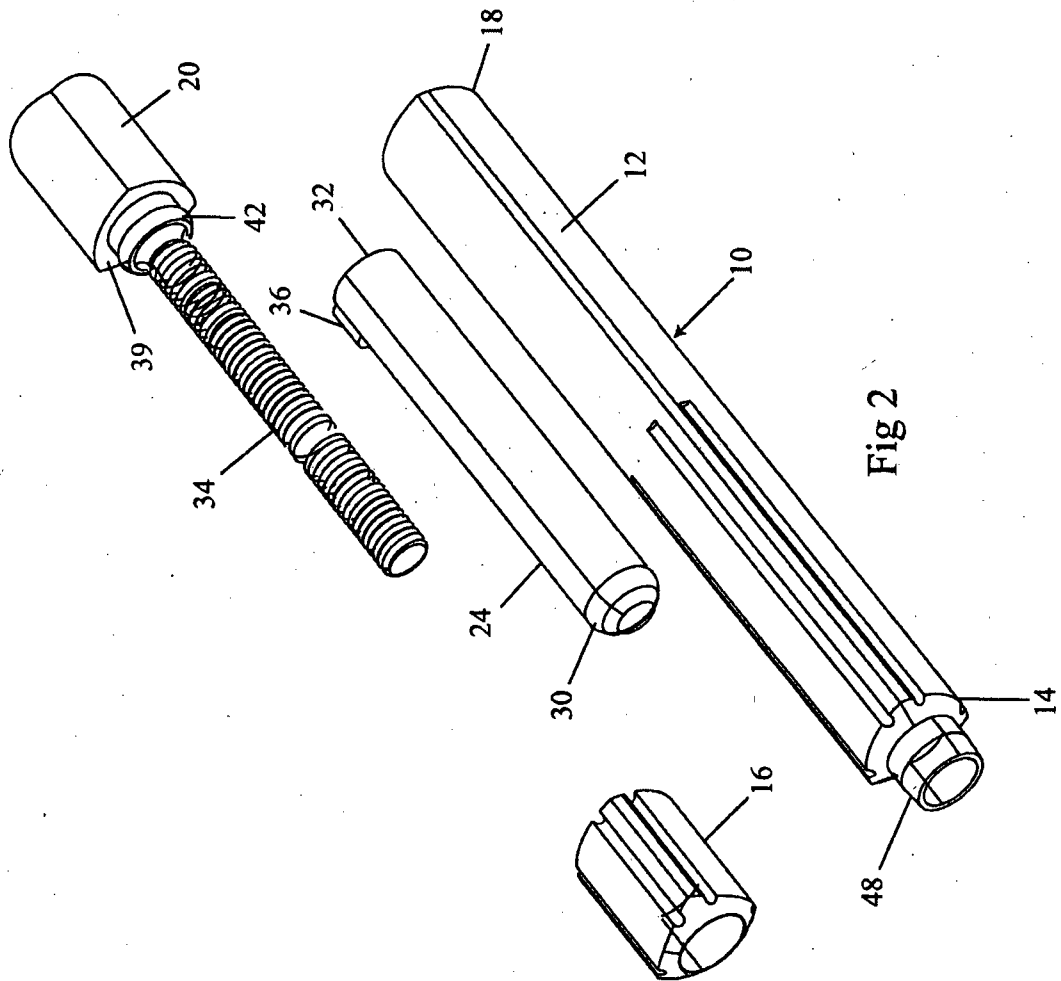

3/3

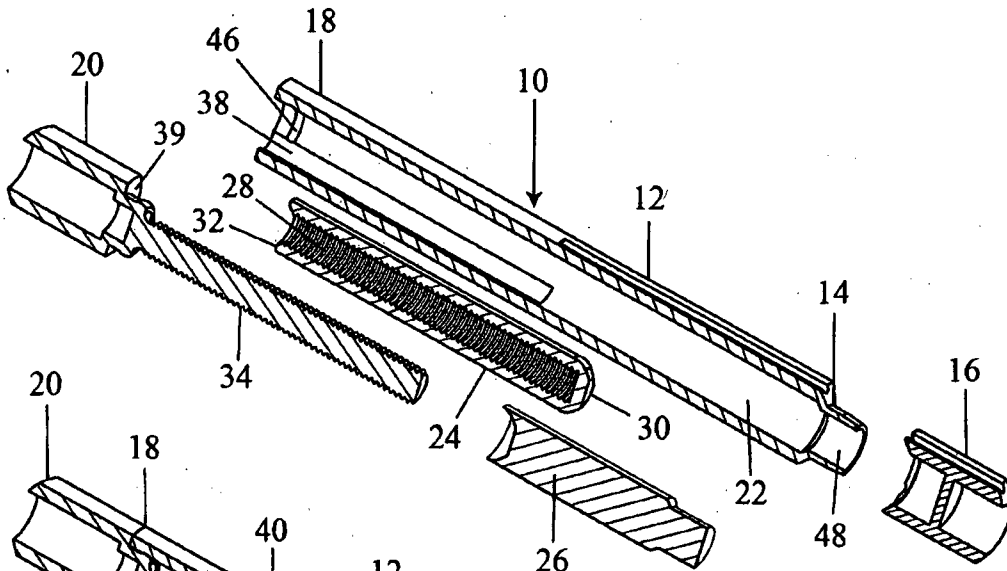

Fig 3a

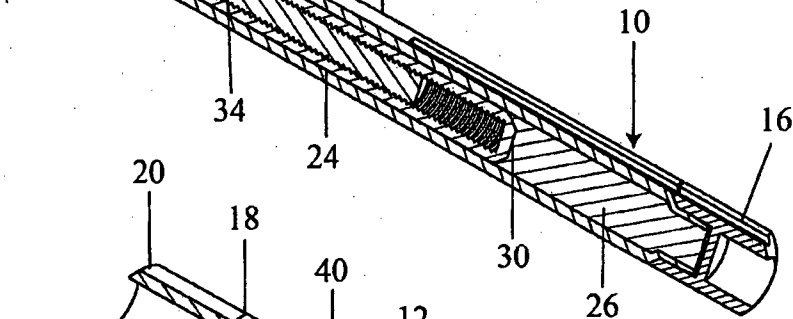

Fig 3b

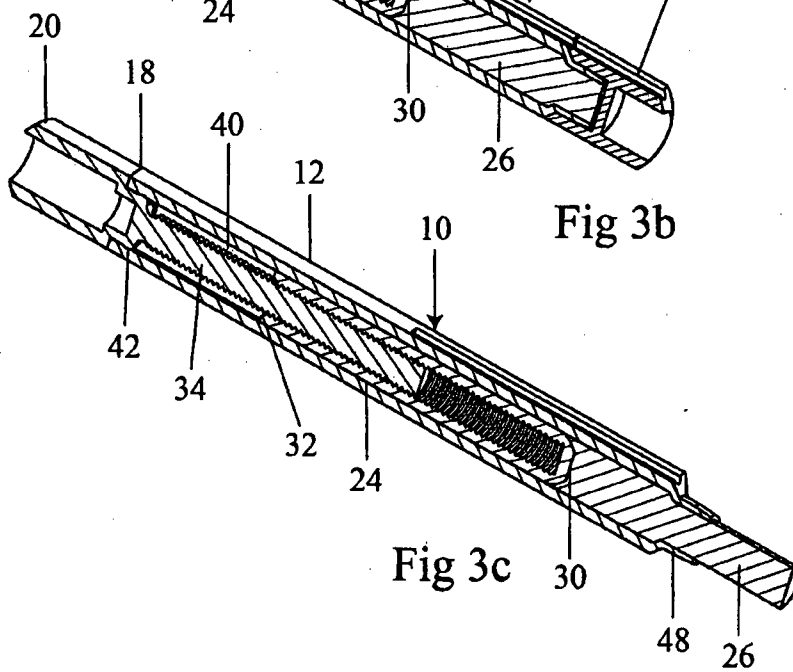

Fig 3c

INTERNATIONAL SEARCH REPORT

International application No.
PCT/AU2012/000683

A. CLASSIFICATION OF SUBJECT MATTER

A61C 5/04 (2006.01) A61M 5/315 (2006.01) B05C 17/01 (2006.01)

According to International Patent Classification (IPC) or to both national classification and IPC

B. FIELDS SEARCHED

Minimum documentation searched (classification system followed by classification symbols)

Documentation searched other than minimum documentation to the extent that such documents are included in the fields searched

Electronic data base consulted during the international search (name of data base and, where practicable, search terms used)

EPODOC and WPI: A61C/IC/EC, A61M/IC/EC, B05C17/01/IC/EC, B65D83/76/IC, B65D83/00A/EC, B67D/IC/EC; keywords: syringe, dental, piston, plunger, screw, thread, rotate, turn, twist, displace, axial, translate, move, longitudinal; and like terms.

GOOGLE PATENTS and ESPACENET: Keywords: dental, syringe, piston, rotate, thread; and like terms.

C. DOCUMENTS CONSIDERED TO BE RELEVANT

Category*	Citation of document, with indication, where appropriate, of the relevant passages	Relevant to claim No.
	Documents are listed in the continuation of Box C	

 Further documents are listed in the continuation of Box C See patent family annex

* Special categories of cited documents:		
"A" document defining the general state of the art which is not considered to be of particular relevance	"T" later document published after the international filing date or priority date and not in conflict with the application but cited to understand the principle or theory underlying the invention	
"E" earlier application or patent but published on or after the international filing date	"X" document of particular relevance, the claimed invention cannot be considered novel or cannot be considered to involve an inventive step when the document is taken alone	
"L" document which may throw doubts on priority claim(s) or which is cited to establish the publication date of another citation or other special reason (as specified)	"Y" document of particular relevance, the claimed invention cannot be considered to involve an inventive step when the document is combined with one or more other such documents, such combination being obvious to a person skilled in the art	
"O" document referring to an oral disclosure, use, exhibition or other means	"&" document member of the same patent family	
"P" document published prior to the international filing date but later than the priority date claimed		

Date of the actual completion of the international search
20 August 2012Date of mailing of the international search report
27 August 2012

Name and mailing address of the ISA/AU

AUSTRALIAN PATENT OFFICE
PO BOX 200, WODEN ACT 2606, AUSTRALIA
Email address: pct@ipaaustralia.gov.au
Facsimile No.: +61 2 6283 7999

Authorized officer

Vivian Cheung
AUSTRALIAN PATENT OFFICE
(ISO 9001 Quality Certified Service)
Telephone No. +61 2 6283 2414

INTERNATIONAL SEARCH REPORT		International application No.
C (Continuation). DOCUMENTS CONSIDERED TO BE RELEVANT		PCT/AU2012/000683
Category*	Citation of document, with indication, where appropriate, of the relevant passages	Relevant to claim No.
X	US 2010/0028831 A1 (PIERSON) 04 February 2010 Fig. 2, 3, 5, 8 and 9; paragraphs [0002], [0035], [0039], and [0045].	1-10
X	US 2010/0282774 A1 (GRETER et al.) 11 November 2010 Fig. 3 and 4; paragraphs [0001], [0054], [0056]	1-10
X	US 2007/0250013 A1 (BRENNAN et al.) 25 October 2007 Fig. 2C-2E; paragraphs [0002], [0005], [0025-0026]	1, 4-10
X	US 5800169 A (MÜHLBAUER) 01 September 1998 Fig. 2; column 1, lines 8-11; column 3, lines 18-32	1-10
X	US 5618273 A (FISCHER) 08 April 1997 Fig. 2, 4-6; column 1, lines 15-22; column 5, lines 13-45	1, 4-10

INTERNATIONAL SEARCH REPORT

Information on patent family members

International application No.

PCT/AU2012/000683

This Annex lists known patent family members relating to the patent documents cited in the above-mentioned international search report. The Australian Patent Office is in no way liable for these particulars which are merely given for the purpose of information.

Patent Document/s Cited in Search Report		Patent Family Member/s	
Publication Number	Publication Date	Publication Number	Publication Date
US 2010/0028831 A1	04 Feb 2010	CA 2624536 A1	12 Apr 2007
		EP 1928344 A1	11 Jun 2008
		JP 2009509670 A	12 Mar 2009
		US 2010028831 A1	04 Feb 2010
		US 8052421 B2	08 Nov 2011
		US 2007072146 A1	29 Mar 2007
		WO 2007041266 A1	12 Apr 2007
US 2010/0282774 A1	11 Nov 2010	CH 698343 A2	15 Jul 2009
		CN 101909527 A	08 Dec 2010
		CN 101918149 A	15 Dec 2010
		EP 2227150 A1	15 Sep 2010
		EP 2227339 A1	15 Sep 2010
		JP 2011509177 A	24 Mar 2011
		US 2010282774 A1	11 Nov 2010
		US 2010288790 A1	18 Nov 2010
		WO 2009086644 A1	16 Jul 2009
WO 2009086650 A1	16 Jul 2009		
US 2007/0250013 A1	25 Oct 2007	CN 101415638 A	22 Apr 2009
		EP 2004540 A2	24 Dec 2008
		JP 2009532194 A	10 Sep 2009
		KR 20090005054 A	12 Jan 2009
		US 2007250013 A1	25 Oct 2007
		WO 2007126656 A2	08 Nov 2007
US 5800169 A	01 Sep 1998	EP 0657143 A1	14 Jun 1995
		JP 7194620 A	01 Aug 1995
		US 5800169 A	01 Sep 1998
US 5618273 A	08 Apr 1997	US 5618273 A	08 Apr 1997

End of Annex