



INTERNATIONAL APPLICATION PUBLISHED UNDER THE PATENT COOPERATION TREATY (PCT)

<p>(51) International Patent Classification ⁶ : F23B 5/04, F23G 5/16, F23M 9/00 // F23L 9/00</p>	A1	<p>(11) International Publication Number: WO 94/15148 (43) International Publication Date: 7 July 1994 (07.07.94)</p>
<p>(21) International Application Number: PCT/NO93/00191 (22) International Filing Date: 14 December 1993 (14.12.93) (30) Priority Data: 925023 28 December 1992 (28.12.92) NO (71) Applicant (for all designated States except US): SINVENT A/S [NO/NO]; N-7034 Trondheim (NO). (72) Inventors; and (75) Inventors/Applicants (for US only): ROSVOLD, Helge [NO/NO]; Nardoskrenten 8, N-7032 Trondheim (NO). ÖSTERBØ, Erling, A. [NO/NO]; Egganveien 26, N-7081 Sjetnemarka (NO). (74) Agent: CURO A/S; P.O. Box 38, N-7094 Lundamo (NO).</p>		<p>(81) Designated States: AU, BR, CA, FI, JP, US, European patent (AT, BE, CH, DE, DK, ES, FR, GB, GR, IE, IT, LU, MC, NL, PT, SE). Published With international search report. In English translation (filed in Norwegian).</p>

(54) Title: GRATE FURNACE

(57) Abstract

A grate furnace for different kind of waste materials such as biomass, mud, and derived fuel, comprising a primary combustion chamber (2) and a secondary combustion chamber (3). A cooled grate (6) for fuel is arranged in the lower edge of the primary combustion chamber (2), and below the grate is provided air supply (5), arranged in a plurality of zones. Furthermore there are provided nozzles (15, 16) for the supply of air to the secondary chamber (3). The primary and the secondary combustion chambers (2, 3) are at least partly separated by a separation plate (10). The zones (5) are individually controllable and are supplied with air and recirculated flue gas, preferably with a high temperature. At least one of the nozzles (15) is adjustable and directed towards the primary air chamber (2), in order to ensure an annealing on the grate (6).

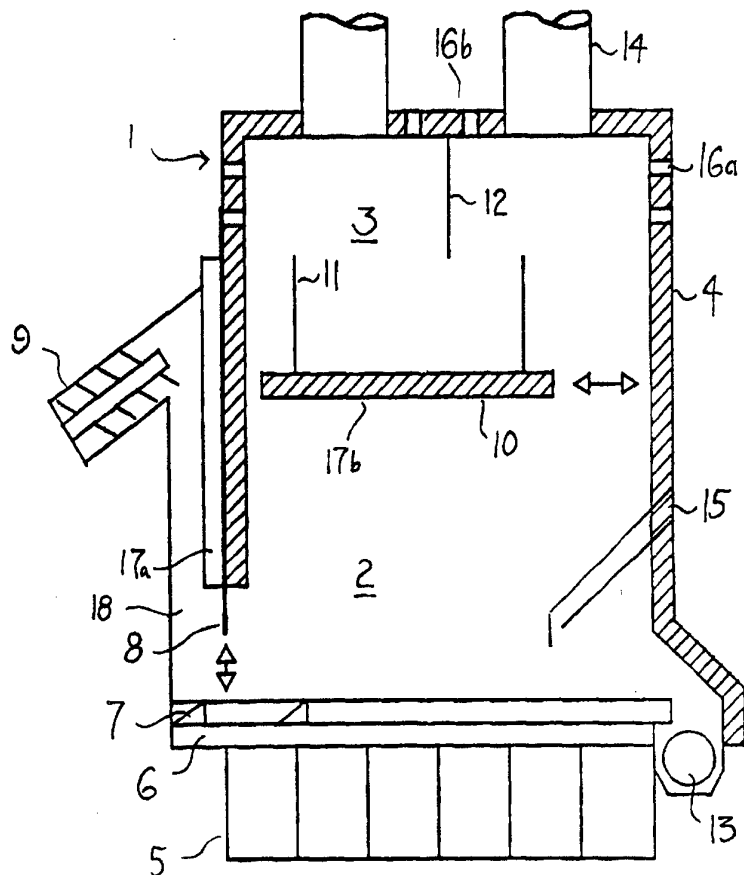

FOR THE PURPOSES OF INFORMATION ONLY

Codes used to identify States party to the PCT on the front pages of pamphlets publishing international applications under the PCT.

AT	Austria	GB	United Kingdom	MR	Mauritania
AU	Australia	GE	Georgia	MW	Malawi
BB	Barbados	GN	Guinea	NE	Niger
BE	Belgium	GR	Greece	NL	Netherlands
BF	Burkina Faso	HU	Hungary	NO	Norway
BG	Bulgaria	IE	Ireland	NZ	New Zealand
BJ	Benin	IT	Italy	PL	Poland
BR	Brazil	JP	Japan	PT	Portugal
BY	Belarus	KE	Kenya	RO	Romania
CA	Canada	KG	Kyrgystan	RU	Russian Federation
CF	Central African Republic	KP	Democratic People's Republic of Korea	SD	Sudan
CG	Congo	KR	Republic of Korea	SE	Sweden
CH	Switzerland	KZ	Kazakhstan	SI	Slovenia
CI	Côte d'Ivoire	LI	Liechtenstein	SK	Slovakia
CM	Cameroon	LK	Sri Lanka	SN	Senegal
CN	China	LU	Luxembourg	TD	Chad
CS	Czechoslovakia	LV	Latvia	TG	Togo
CZ	Czech Republic	MC	Monaco	TJ	Tajikistan
DE	Germany	MD	Republic of Moldova	TT	Trinidad and Tobago
DK	Denmark	MG	Madagascar	UA	Ukraine
ES	Spain	ML	Mali	US	United States of America
FI	Finland	MN	Mongolia	UZ	Uzbekistan
FR	France			VN	Viet Nam
GA	Gabon				

Grate furnace

The present invention concerns a grate furnace for alternative fuel, as stated in the introductory part of claim 1.

5 The so called "Refined Derived Fuel", RDF, is the result of sorting out non-combustible elements from household waste, etc. This is mixed with cortex and wood chips in order to achieve a better calorific value. This fuel is combusted in special furnaces to extract the optimum amount of energy with pollution as low as possible. Such furnaces should also be able to take other solid materials, such as all kinds of
10 biomass, mud, and certain types of hazardous waste.

In principle, a furnace for combustion of RDF operates in a manner where the fuel is supplied at a grate which is located over a primary air chamber, the chamber often being divided in sections. The combustion furnace is divided into a primary chamber and a secondary chamber, where the fuel is combusted in two steps.

15 Disadvantages with known grate furnaces of this type is that it is difficult to achieve an optimum combustion, both for utilization of energy and reduction of pollution. This is substantially due to the furnaces not being flexible, and not including control options for adjustment of fuel of different consistency and content.

It is thus an object of the present invention to provide a grate furnace for refined
20 derived fuel, which can be adjusted to the kind of fuel present, in order to achieve a combustion process as optimal as possible, with respect to energy utilization and reduction of pollution.

The object of the invention is achieved with a device having features as stated in the characterizing part of claim 1. Further features are clear from the dependent
25 claims.

In the following, the invention will be described with reference to a preferred embodiment, and with reference to the accompanying drawings, in which

Fig. 1 disclose the principles of a grate furnace according to present invention, and
Fig. 2 disclose in more details a grate furnace according to present invention.

30

Referring firstly to Fig. 1, there is shown a grate furnace generally denoted 1, which is divided into a primary chamber 2 and a secondary chamber 3. The primary-

and secondary chambers 2, 3 are protected by a surrounding insulation 4. Below the primary chamber 2 is located a primary air chamber 5 which is divided into a plurality of sections for flexible supply of primary air and recirculated flue gas. Above the primary air chamber 5 is located a grate 6 adapted to energy-rich fuel (e.g. RDF). The grate 6 is cooled, e.g. by water. The grate is constructed to give a high pressure drop. Above the grate 6 is located a feeder 7, supplying fuel to the grate 6. A guillotine 8 control the amount of fuel supplied by the feeder 7. The guillotine 8 ensures a good control option for the fuel height above the grate 6, and a stable and even fuel distribution over the entire width of the grate 6. The fuel is supplied from a fuel stock (not shown), by means of a feed screw 9, to a fuel container 18 in the area outside of the guillotine 8. The fuel container 18 is preferably insulated/cooled, so that it does not cause exhaust gas from the fuel to occur.

The primary chamber 2 and the secondary chamber 3 are separated by a separating plate 10. The separating plate 10 is movable both in height and lateral direction, in order to vary the volume of the two chambers 2, 3 and furthermore, to direct the gas flow in the desired direction. By moving the separating plate 10 in forward and backward directions, respectively, the flow pattern can be influenced, and it can be determined whether the flue gas is to leave the primary chamber 2 at the leading edge, the trailing edge, or both. Preferably baffles 11 are arranged on the separating plate 10, to ensure good mixing and turbulence in the secondary chamber 3. The baffles are also movable to a desired position and may optionally be removed or interchanged with baffles having a different geometry. Also in the top wall is arranged a baffle 12.

An ash hopper 13 is arranged away from and below the grate 6 on the opposite side of the feeding area. In the top wall of the combustion chamber is arranged at least a flue outlet 14.

In the wall 4 of the combustion chamber are arranged nozzles 16a for secondary air. Preferably further nozzles for tertiary air are also arranged in the area 16b.

The grate furnace 1 operates by dehydration, degassing and pyrolysis being carried out in the primary chamber 2. In the secondary chamber 3 combustion of gases is performed. The temperature in the primary chamber 2 is preferably in the range 500-700 °C, while the secondary chamber has a temperature of approximately 1000 °C.

The temperature in the primary chamber 2 is set to impede degassing of heavy metal, and the formation of cinders. The temperature in the secondary chamber 3 is set to ensure a good combustion of organic and chlororganic compounds. Low air velocity in the primary chamber is meant to restrict the transporting of dust particles. In addition, regulation of the temperature is determined by restricting the air supply to the primary chamber. This is performed by a plurality of the zones in the primary air chamber 5 being individually controllable, i.a. to avoid cooling in areas where the temperature is under control. By regulating the temperature control through air supply in the primary chamber, it is possible to stay below the critical temperatures at which cinder form.

At the end of the grate 6 combustion of solid carbon is ensured by a combination of controlled annealing, increased resistance at the end of the grate and screening of the ash from the remainder of the combustion chamber. Annealing is achieved by leading air and recirculated flue gas combining with flue gas and secondary air through a nozzle 15 located in the wall of the combustion chamber, so that it screens the zone for combustion of the ash from the remaining combustion chamber. This air is simultaneously meant to establish a tension pattern where heat from the annealing zone is moved to the supply zone and ensures an even pyrolysis activity. Dimensioning and geometry of the nozzles 15 should be adjusted to the amount of recirculated amount of gas and the flow pattern desirable in the primary air chamber 2. Output of flue gas at the flue gas outlets 14 should be varied dependent upon what flow pattern is desirable in the secondary chamber. To ensure flexibility in the flow pattern, a flue outlet is preferably situated both in the leading and the trailing edge of the secondary chamber 3. Secondary air nozzles 16a, 16b are dimensioned for the actual amount of air and the flow pattern desirable in the secondary chamber 3. The secondary air nozzles 16a, 16b are formed such that each can vary output velocity and output angle of the air. The location of the secondary air nozzles as shown is ment as an example. The nozzles 16a in the walls of the secondary air chamber are dimensioned on the basis of the volume of the secondary chamber in order to achieve velocity and a direction leading to good mixing. The air pre-heating in the wall between the combustion chamber 2, 3 and the fuel container 18 also provide insulation to the fuel container and prevent high temperatures in the fuel container. The heat output should,

however, not be so great that the temperatures in the primary and secondary chamber 2, 3 are influenced to a negative degree.

In Fig. 2 there is shown a more detailed example of an embodiment of present invention. Broadly the construction and operational mode is similar to what is described above with reference to Fig. 1. The combustion chamber is divided into a primary chamber 2 and a secondary chamber 3 which is surrounded by an insulated steel mantel 4. The two chambers 2, 3 are separated by horizontal separating plate 10, which at its ends merges into vertical baffles 11. Turbulence in the secondary chamber is secured by vertical baffle 12. Below the grate 6 is arranged five primary air boxes 5 for distribution of primary air. These are furnished with supply pipes 21 for recirculated flue gas, and supply pipes 22 for primary air which is heated by a heat element 25.

The guillotine 8 adjusts the height of the fuel being supplied to the grate 6. The fuel emerges from the cell feeder 9, which simultaneously shuts off air to the fuel container 18 and provides for closing off the fuel feed. Before the ash is transported from the grate 6 to the ash hopper 13, pre-combustion and annealing by means of adjusted air supply and resistance is performed in the ash combustion chamber 19.

Secondary air is supplied through nozzles 15, 16a and 16c, and tertiary air is supplied through nozzles 16b.

The grate 6 is cooled by the supply of cooling medium through the supply pipes 20. A cooling element 23 is arranged on the flue gas duct 14, so as to cool the flue gas before moving through the pipe 24. Furthermore, in Fig. 2 there is shown an observation glass through which the combustion process can be observed.

Claims:

1. Grate furnace for different kind of waste material such as biomass, mud, and derived fuel; comprising a primary combustion chamber (2) and a secondary combustion chamber (3), wherein a cooled grate (6) for fuel is arranged in the lower edge of the primary combustion chamber (2), and air supply (5), arranged in a
5 plurality of zones, is provided below the grate, furthermore are provided nozzles (15, 16) for supply of air to the secondary chamber (3), **characterized** by the primary and the secondary combustion chambers (2, 3) being at least partly separated by a separation plate (10), and that the zones (5) are individually controllable and supplied with air and recirculated flue gas, preferably with a high temperature, and that at
10 least one of the nozzles (15) is adjustable and directed towards the primary air chamber (2), in order to ensure an annealing on the grate (6).
2. Furnace according to claim 1,
characterized by the separation plate (10) being adjustable in lateral direction.
3. Furnace according to claim 1 or 2,
15 **characterized** by the separation plate (10) being adjustable in height direction.
4. Furnace according to any one of claims 1-3,
characterized by the separation plate (10) being provided with baffles (11), which can be moved on the separation plate, and can have different geometry.
5. Furnace according to any one of claims 1-4,
20 **characterized** by further baffles (12) being provided in the top wall of the combustion chamber.
6. Furnace according to any one of claims 1-5,
characterized by the mixing of air and flue gas to the zones (5) being controlled by measured values of the temperature in the primary and secondary combustion chambers (2, 3), respectively, and the composition of the exhaust through flue outlets (14).
25

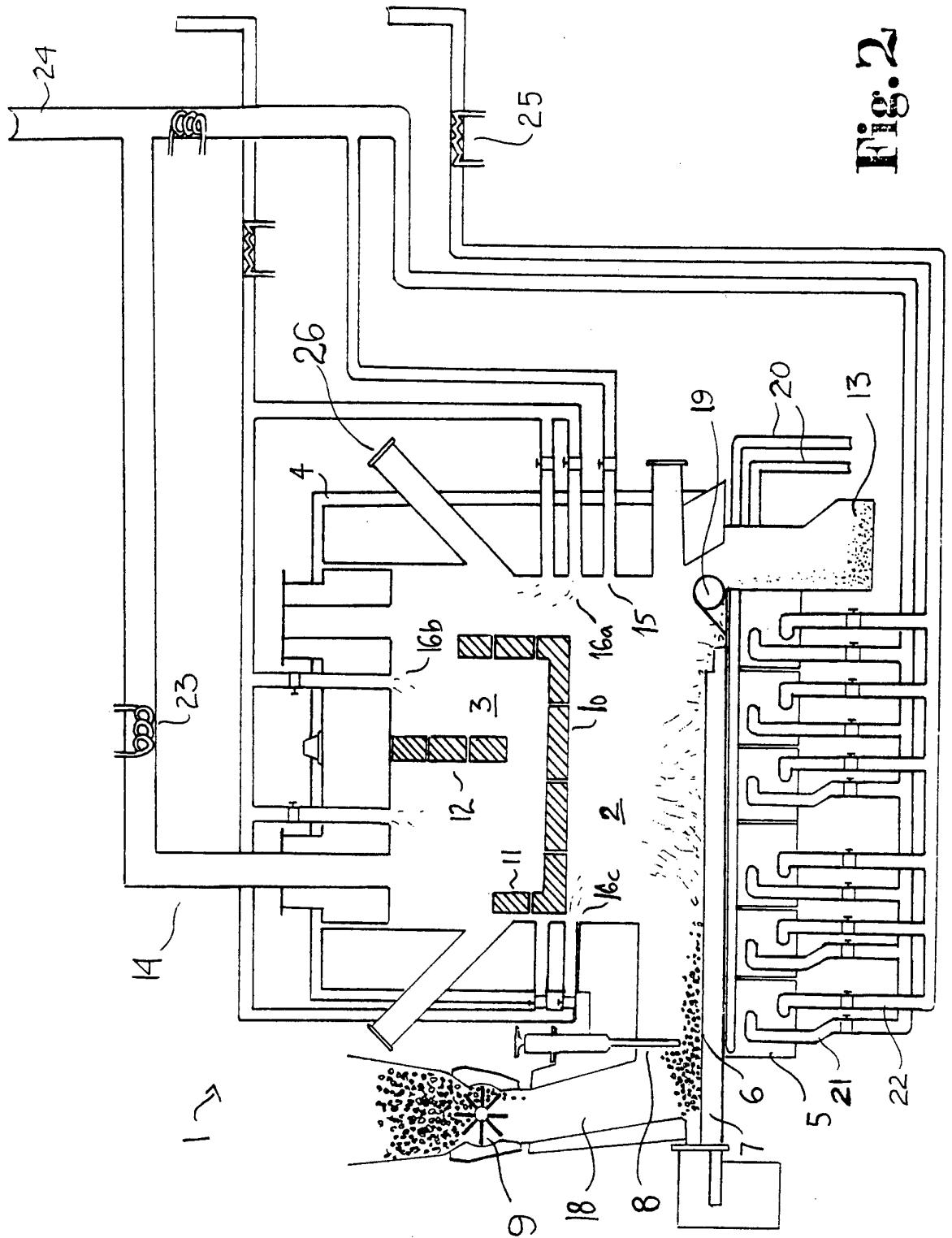

Fig. 2

INTERNATIONAL SEARCH REPORT

International application No.

PCT/NO 93/00191

A. CLASSIFICATION OF SUBJECT MATTER

IPC6: F23B 5/04, F23G 5/16, F23M 9/00 // F23L 9/00
According to International Patent Classification (IPC) or to both national classification and IPC

B. FIELDS SEARCHED

Minimum documentation searched (classification system followed by classification symbols)

IPC6: F23B, F23L, F23M, F23G

Documentation searched other than minimum documentation to the extent that such documents are included in the fields searched

SE,DK,FI,NO classes as above

Electronic data base consulted during the international search (name of data base and, where practicable, search terms used)

C. DOCUMENTS CONSIDERED TO BE RELEVANT

Category*	Citation of document, with indication, where appropriate, of the relevant passages	Relevant to claim No.
A	SE, B, 305274 (AB DESTRUCTOR), 21 October 1968 (21.10.68), partition (21) --	
A	US, A, 4446800 (LÖVGREN), 8 May 1984 (08.05.84), grate (4)primary air supply --	
A	EP, A1, 0381946 (W + E UMWELTECHNIK AG), 16 August 1990 (16.08.90) --	
A	US, A, 3808619 (VANDERVEER), 7 May 1974 (07.05.74), partition, adjustable air supply --	

Further documents are listed in the continuation of Box C.

See patent family annex.

* Special categories of cited documents:

"A" document defining the general state of the art which is not considered to be of particular relevance

"E" earlier document but published on or after the international filing date

"L" document which may throw doubts on priority claim(s) or which is cited to establish the publication date of another citation or other special reason (as specified)

"O" document referring to an oral disclosure, use, exhibition or other means

"P" document published prior to the international filing date but later than the priority date claimed

"T" later document published after the international filing date or priority date and not in conflict with the application but cited to understand the principle or theory underlying the invention

"X" document of particular relevance: the claimed invention cannot be considered novel or cannot be considered to involve an inventive step when the document is taken alone

"Y" document of particular relevance: the claimed invention cannot be considered to involve an inventive step when the document is combined with one or more other such documents, such combination being obvious to a person skilled in the art

"&" document member of the same patent family

Date of the actual completion of the international search

20 April 1994

Date of mailing of the international search report

20 -04- 1994

Name and mailing address of the ISA/
Swedish Patent Office
Box 5055, S-102 42 STOCKHOLM
Facsimile No. +46 8 666 02 86

Authorized officer

Annette Riedel
Telephone No. +46 8 782 25 00

INTERNATIONAL SEARCH REPORT

International application No.

PCT/NO 93/00191

C (Continuation). DOCUMENTS CONSIDERED TO BE RELEVANT

Category*	Citation of document, with indication, where appropriate, of the relevant passages	Relevant to claim No.
A	FR, E, 47268 (HENRI HAMOT), 5 March 1936 (05.03.36), partition (s) --	
A	Patent Abstracts of Japan, Vol 9, No 238, M-416, abstract of JP, A, 60-93207 (MATSUSHITA DENKI SANGYO K.K.), 25 May 1985 (25.05.85), detail (14) --	
A	DE, C, 929082 (HEINRICH VORKAUF), 20 June 1955 (20.06.55), partition (2) --	
A	DE, B, 1057276 (RUDOLF HINGST), 14 May 1959 (14.05.59), partition (14) --	
A	SE, B, 445771 (SCANDIACONSULT AB), 14 July 1986 (14.07.86) --	
A	Patent Abstracts of Japan, Vol 13, No 498, M-890, abstract of JP, A, 1-200104 (ISHIKAWAJIMA HARIMA HEAVY IND CO LTD), 11 August 1989 (11.08.89) --	
A	Derwent's abstract, No 92-173703/21, week 9221, ABSTRACT OF SU, 1657859 (UKR COAL ENRICHMENT BRIQUETTING INST), 23 June 1991 (23.06.91) --	
A	Patent Abstracts of Japan, Vol 9, No 38, M-358, abstract of JP, A, 59-180213 (TAKUMA K.K.), 13 October 1984 (13.10.84) --	
A	DE, C, 628089 (DEUTSCHE BABCOCK & WILCOX DAMPFKESSEL-WERKE AKT.- GES. IN OBERHAUSEN), 28 March 1936 (28.03.36) --	

INTERNATIONAL SEARCH REPORT

International application No.

PCT/NO 93/00191

C (Continuation). DOCUMENTS CONSIDERED TO BE RELEVANT

Category*	Citation of document, with indication, where appropriate, of the relevant passages	Relevant to claim No.
A	Patent Abstracts of Japan, Vol 13, No 189, M-821, abstract of JP, A, 1-14512 (NGK INSULATORS LTD), 18 January 1989 (18.01.89) -- -----	

INTERNATIONAL SEARCH REPORT

Information on patent family members

26/02/94

International application No.

PCT/NO 93/00191

Patent document cited in search report	Publication date	Patent family member(s)	Publication date
SE-B- 305274	21/10/68	NONE	
US-A- 4446800	08/05/84	CA-A- 1187338 EP-A,B- 0060236	21/05/85 15/09/82
EP-A1- 0381946	16/08/90	SE-T3- 0381946 DE-D- 59003177	00/00/00
US-A- 3808619	07/05/74	NONE	
FR-E- 47268	05/03/36	NONE	
DE-C- 929082	20/06/55	NONE	
DE-B- 1057276	14/05/59	NONE	
SE-B- 445771	14/07/86	CA-A- 1239834 EP-A- 0162864	02/08/88 04/12/85
DE-C- 628089	28/03/36	NONE	