



HU000030633T2

(19) **HU**(11) Lajstromszám: **E 030 633**(13) **T2****MAGYARORSZÁG**  
Szellemi Tulajdon Nemzeti Hivatala**EURÓPAI SZABADALOM**  
**SZÖVEGÉNEK FORDÍTÁSA**

- (21) Magyar ügyszám: **E 12 705906**
- (22) A bejelentés napja: **2012. 01. 27.**
- (96) Az európai bejelentés bejelentési száma:  
**EP 20120705906**
- (97) Az európai bejelentés közzétételi adatai:  
**EP 2806735 A1**                      **2013. 08. 01.**
- (97) Az európai szabadalom megadásának meghirdetési adatai: (86) A nemzetközi (PCT) bejelentési szám:  
**EP 2806735 B1**                      **2016. 06. 08.**                      **PCT/HU 12/000007**
- (87) A nemzetközi közzétételi szám:  
**WO 13110962**
- (51) Int. Cl.: **A01N 25/00**                      (2006.01)  
**A01M 25/00**                      (2006.01)  
**A01N 25/34**                      (2006.01)  
**A01N 33/18**                      (2006.01)  
**A01N 43/16**                      (2006.01)  
**A01P 11/00**                      (2006.01)

(72) Feltaláló(k): <b>BAJOMI, Dániel, 1055 Budapest (HU)</b> <b>DARU, János, 1172 Budapest (HU)</b> <b>HALASI, Attila, 1106 Budapest (HU)</b> <b>POZSÁR, Vince, 2941 Ács (HU)</b> <b>SCHMIDT, József, 2060 Bicske (HU)</b> <b>SZILÁGYI, János, 1126 Budapest (HU)</b> <b>TAKÁCS, László, 1237 Budapest (HU)</b> <b>TOMCSIK, József, 1033 Budapest (HU)</b>	(73) Jogosult(ak): <b>Bábolna Környezetbiológiai Központ Kft.,</b> <b>1107 Budapest (HU)</b>
	(74) Képviseelő: <b>SBGK Szabadalmi Ügyvivői Iroda, Budapest</b>

(54) **Rágcsálóirtó eszköz**

Az európai szabadalom ellen, megadásának az Európai Szabadalmi Közlönyben való meghirdetésétől számított kilenc hónapon belül, felszólalást lehet benyújtani az Európai Szabadalmi Hivatalnál. (Európai Szabadalmi Egyezmény 99. cikk(1))

A fordítást a szabadalmas az 1995. évi XXXIII. törvény 84/H. §-a szerint nyújtotta be. A fordítás tartalmi helyességét a Szellemi Tulajdon Nemzeti Hivatala nem vizsgálta.



(11) **EP 2 806 735 B1**

(12) **EUROPEAN PATENT SPECIFICATION**

(45) Date of publication and mention  
of the grant of the patent:  
**08.06.2016 Bulletin 2016/23**

(51) Int Cl.:  
**A01N 25/00** (2006.01) **A01N 25/34** (2006.01)  
**A01N 33/18** (2006.01) **A01N 43/16** (2006.01)  
**A01M 25/00** (2006.01) **A01P 11/00** (2006.01)

(21) Application number: **12705906.1**

(86) International application number:  
**PCT/HU2012/000007**

(22) Date of filing: **27.01.2012**

(87) International publication number:  
**WO 2013/110962 (01.08.2013 Gazette 2013/31)**

(54) **RODENT CONTROL DEVICE**

ZUSAMMENSETZUNG ZUR BEKÄMPFUNG VON NAGETIEREN

COMPOSITION POUR LA LUTTE CONTRE LES RONGEU

(84) Designated Contracting States:  
**AL AT BE BG CH CY CZ DE DK EE ES FI FR GB  
GR HR HU IE IS IT LI LT LU LV MC MK MT NL NO  
PL PT RO RS SE SI SK SM TR**  
Designated Extension States:  
**BA ME**

- **POZSÁR, Vince**  
2941 Ács (HU)
- **SCHMIDT, József**  
2060 Bicske (HU)
- **SZILÁGYI, János**  
1126 Budapest (HU)
- **TAKÁCS, László**  
1237 Budapest (HU)
- **TOMCSIK, József**  
1033 Budapest (HU)

(43) Date of publication of application:  
**03.12.2014 Bulletin 2014/49**

(73) Proprietor: **Bábolna Környezetbiológiai Központ  
Kft.**  
**1107 Budapest (HU)**

(74) Representative: **Lang, Tivadarné**  
**SBGK Patent and Law Offices**  
**Andrássy út 113.**  
**H-1062 Budapest (HU)**

(72) Inventors:

- **BAJOMI, Dániel**  
1055 Budapest (HU)
- **DARU, János**  
1172 Budapest (HU)
- **HALASI, Attila**  
1106 Budapest (HU)

(56) References cited:  
**EP-A1- 2 090 164 EP-A1- 2 497 362**  
**EP-A2- 0 475 551 BE-A1- 904 052**  
**BE-A4- 904 203 US-A- 4 891 218**

**EP 2 806 735 B1**

Note: Within nine months of the publication of the mention of the grant of the European patent in the European Patent Bulletin, any person may give notice to the European Patent Office of opposition to that patent, in accordance with the Implementing Regulations. Notice of opposition shall not be deemed to have been filed until the opposition fee has been paid. (Art. 99(1) European Patent Convention).

**Description**

**[0001]** The present invention relates to a device for controlling rodents. More specifically, it relates to a device consisting of a combination of a solid and a pulpy bait (commonly known as 'fresh bait' or 'pasta bait' in rodent control practice), wherein the solid part is a shaped paraffinized rodenticide bait with a rodenticide concentration which is lower than or equal to the rodenticide concentration of the combination and contains the pulpy rodenticide bait with a rodenticide concentration which is higher than or equal to the rodenticide concentration of the combination. The rodent control device according to the invention has an enhanced acceptance by the rodents and can preferably be fixed by a hole formed in the solid part preventing the rodents to take it away. Furthermore, the present invention relates to the preparation and use of such rodent control device.

**[0002]** As a result of the multiplication of rodent populations over the past decades, the control of rodents, especially mice and rats, has become a well-known issue of high importance. Besides health concerns and especially in bigger cities, issues about rodents include major damage in food storages, and they may be carriers of diseases which affect both humans and farm animals.

**[0003]** Over the years, various attempts have been made to control rodents and numerous methods have been developed, including physical and chemical methods.

**[0004]** Physical methods include the use of mechanical devices such as glues, traps (e.g., see EP 0599755 A1, EP 1149530 A2) and electric devices, these latter killing rodents via electric shocks (e.g., see WO 99/018780).

**[0005]** In general, chemical methods refer to devices containing a rodenticide poison (hereinafter also referred to as "rodenticide active ingredient" or "rodenticide") in a carrier edible for rodents. During the past years, several types of chemical baits for indoor and outdoor domestic uses have been placed onto the market. These products may have various consistencies.

The main types of products include:

**[0006]** Solid products, in which rodenticide active ingredients are added to a composition consumable by rodents, such as cereal and/or fruit aggregates, milling products, flours, and mixtures containing animal parts, especially insect parts. In order to increase acceptance/palatability, such compositions also contain aromas, flavours, vegetable oils, fruits, fish, sugar and the like. It is also well-known that such baits may contain colouring agents, preservatives and bittering substances (repellents). The main reason for adding the latter is to prevent human consumption, especially consumption by children.

**[0007]** One group of solid products includes products based on milled cereals (loose baits). Although milled cereal based products are especially effective rodenticides, they have the disadvantage of being easily spilled and thus may cause major environmental pollution.

**[0008]** BE 904052 and BE 904203 discloses rodenticide products based on fresh fruits, roots or vegetables for use as baits, which contain the rodenticide active ingredient in one or more holes inside a tube-like case. Such products include drilled carrots, sugar-beets, beetroots and the like. Such solutions have the disadvantage of making it possible for the rodent to consume the food favourable to it without necessarily getting at the poison-containing internal core. Another drawback is that they are mostly limited to hand-made preparation and uses while their industrial scale production and shelf-lives may be problematic.

**[0009]** Another form of solid poisonous baits are paraffin-wax-based products in which the rodenticide active ingredient and other components are mixed with paraffin wax. These are generally produced in the form of blocks. For example, US 4,891,218 discloses a paraffinized rodenticide bait block, wherein the physical structure and shape of the block, such as the ridged surface and edges, ensure effective consumption by the rodent and, therefore, the rodenticide effect. Preferably, the dimensions of the block are selected in a manner to provide sufficient amounts of poison to kill an average-sized rodent.

**[0010]** One advantage of paraffinized products is their solid state; therefore, they can be easily fixed and rodents cannot take it away from the place of application. In addition, they are more resistant to humidity than the products packed in cellulose bags and thus may be used in humid environments, too. However, one disadvantage of paraffin wax is that rodents do not like it and it reduces the acceptance/palatability of the bait. Another drawback is that in known extruded paraffinized blocks the concentration of the active ingredient is the same on the surface and inside, therefore, nothing reduces the exposure and poisoning resulting from regular or long-term contact with the bait.

**[0011]** Another type of products includes pulpy products also known as paste products. Typically, pulpy products contain elevated levels of attractive oils and fats of high nutritional value, therefore, they are highly acceptable and tasteful for rodents. In order to prevent rancidity, antioxidants are also typically added to these products. Pulpy baits are generally available in sachets and this results in considerable amounts of the rodent-attracting oil content to ooze out of the sachet during the warm summer months; thus, it becomes unattractive to the rodent, difficult to handle, and with increased risk of contamination for the user and the environment. Another important disadvantage of pulpy baits is the

difficulty or impossibility to fix them, and rodents will take them away to their hiding places which results in environmental pollution via scattering. By creating a possibility for undesired consumption of the rodenticide-containing baits, such scattered baits may present a risk to non-target organisms such as farm animals.

5 [0012] Known products also include combined products containing a synergistic combination of active ingredients to increase their killing efficiency. For example, EP 2090164 A1 discloses a rodenticide bait containing a synergistic combination of two anticoagulant ingredients, preferably in the form of paraffinized blocks.

10 [0013] EP 1279334 discloses a combined bait with rat killing effect, which contains a rodenticide active ingredient and a bait composition, wherein the bait composition contains a component tasteful for rodents in a paste form, which contains flour of animal and/or plant origin, i.e., a solid component suitable for chewing. Preferably, this solid component is selected from the group of cereals, expanded cereals, fruits, vegetables and flour aggregates, wherein the fruits and vegetables are present in small, preferably dried pieces. Basically, the claimed combined bait mix is an improved pulpy bait prepared by first dispersing one part of the rodenticide active ingredient in a liquid carrier, such as glycol, mixing it with the solid bait component, preferably in a pulper equipment, and then letting it stand for a time to allow the rodenticide active ingredient to be absorbed by the solid component. Next, powder-like components are added to the rest of the rodenticide active ingredient under continuous mixing, and the mixture is then let stand for 45 to 60 minutes to ensure even dispersion of the rodenticide active ingredients. The obtained bait is filled into single-dose filter paper sachets. Therefore, this method essentially produces a pulpy bait in which chewable food pieces - which are either milled to a grain size coarser than that of flour or unmilled - are dispersed. This is also demonstrated by the examples, in which the specified mixes contain 58% to 60% crop/animal flours, 15% whole, expanded grains and fruit/vegetable granulates and 18% to 20% fat-like materials. The rodenticide active ingredient is evenly dispersed in the coarse (middling sized) solid bait component and the flour-containing pulpy bait. Although the data presented herein suggest that rats consume the combined bait very well, the risk of scattering still remains due to the sachet packaging.

15 [0014] Accordingly, there is still a great need for new rodenticide products that eliminate the disadvantages of the above-mentioned types.

25 [0015] One objective of the present invention is to provide a rodent control device which is highly attractive for and fully consumable by rodents, even in the presence of usual foods.

[0016] Another objective of the invention is to provide a rodent control device which effectively kills a wide range and the largest number of rodents, and, at the same time, is fixable and thus cannot be taken away, thereby having a lower potential for environmental pollution and undesired poisonous effects.

30 [0017] Another objective of the invention is to provide a rodent control device which presents less risks to all those qualified and unqualified individuals that come into contact with it than the known paraffinized products. In general, it presents lower risks than the rodenticide active ingredients which are non-individually packaged in materials impermeable for the rodenticide, and containing one dose for a single application, as well as than the grain or coarse baits, which get easily spilled.

35 [0018] The above objectives can be achieved by the rodent control device of the present invention. Our experiments suggested that combining a solid paraffinized bait with a pulpy bait in a manner that the pulpy bait having a rodenticide concentration which is greater than or equal to the overall rodenticide concentration of the system is comprised in the shaped paraffinized solid bait having a rodenticide concentration which is less than or equal to the overall rodenticide concentration of the system and selecting the appropriate ratio of these main ingredients will result in a product of the desired active ingredient levels, which rodents will readily start to consume and will rapidly arrive to the delicious pulpy bait and, by consuming that, to the lethal dose.

40 [0019] The use of lower active ingredient levels in the external rigid part has the further advantage of reducing the risk of poisoning those handling the rodenticide product when in contact with it.

45 [0020] Accordingly, the object of the present invention is a rodent control device, which is a combination of a solid and a pulpy bait, wherein the solid part is a shaped paraffinized rodenticide bait with a rodenticide concentration lower than that of the combination, said solid part comprising the pulpy rodenticide bait having a rodenticide concentration higher than that of the combination.

50 [0021] Another object of the present invention is a rodent control device, which is a combination of a solid and a pulpy bait, wherein the solid part is a shaped paraffinized rodenticide bait with a rodenticide concentration equal to that of the combination, said solid part comprising the pulpy rodenticide bait having a rodenticide concentration equal to that of the combination.

[0022] In the rodent control device of the present invention, the percentage rate of the solid part and of the pulpy part compared to the total mass of device is preferably 70-90 for the one part and 10-30 for the other, more preferably 75-87 and 13-25 and most preferably 86.6 and 13.4.

55 [0023] In the rodent control device according to the invention, the ratio of the active ingredient in the solid part and in the pulpy part may be 1:1 to 1:70.

[0024] The combined rodenticide bait according to the invention is different from that described in EP 1279334 on several points; among others, the solid part is shaped, paraffin-containing and fixable; the solid bait and the pulpy bait

components are not in the form of mixtures but the two types of baits, that is, the solid bait and the pulpy bait are definitively separate from each other; the concentration of the rodenticide active ingredient is different in the two bait components, that is, the solid part and the pulpy part contains rodenticide active ingredients in lower and higher levels, respectively, and the appearance of the combined bait is also different from the known product.

5 **[0025]** The solid bait component of the rodent control device of the invention comprises paraffin, wax and/or tallow, as well as an edible oil, grained, pressed, expanded, granulated or milled cereals, crops in the form of groats or flour, maize, rodenticide active ingredient, a sweetening agent, a preservative, dried and milled insects, and fruit pieces and vegetable aggregates. The solid component may contain colouring agents to prevent human consumption, and repellent agents such as denatonium benzoate, which are repulsive to humans and farm animals. The amount of the solid bait component is 70% to 90% (w/w) of the total mass of the rodent control device. Depending on the type of rodenticide ingredient, the solid bait component comprises the rodenticide in an amount of 0.0001% to 0.1% (w/w) of the total mass of the rodent control device.

10 **[0026]** The pulpy bait component of the rodent control device according to the invention is well accepted by rodents and contains cereal flours, oils/fats of plant origin and/or oils/fats of animal origin, an antioxidant, such as butyl hydroxyanisole, butyl hydroxytoluene, Vitamin A, Vitamin C, Vitamin E, flavours and/or aromas attractive for rodents, taste intensifiers such as salt, glutamic acid and salts thereof, guanic acid and salts thereof, inosinic acid and salts thereof, maltol and esters thereof, a sweetening agent, milled insects and a rodenticide active ingredient. The pulpy component may contain colouring agents, preferably with colours different from that of the solid bait part to prevent human consumption, and repellent agents such as denatonium benzoate, which are repulsive to humans and farm animals. The amount of the pulpy bait component is 10% to 30% (w/w) of the total mass of the rodent control device. Depending on the type of rodenticide ingredient, the pulpy bait component comprises the rodenticide in an amount of 0.0001% to 0.3% (w/w) of the total mass of the rodent control device.

15 **[0027]** The rodenticide active ingredient used in the rodent control device of the invention may be an acute rodenticide, that is, a poison such as scilliroside, strychnine, crimidine, bromethalin, sodium fluoroacetate, fluoroacetamide, zinc phosphide, norbormide, thallium sulphate, alpha-chloralose and alpha-naphthylthiourea or a mixture thereof; or it can be a chronic rodenticide, that is, a first generation anticoagulant such as warfarin, warfarin sodium, coumachlor, coumate-tralyl, coumafuryl, pivaldione, diphacinone, chlorophacinone or a mixture thereof; or a second generation anticoagulant such as bromadiolone, diphenacoum, brodifacoum, difethialone and flocoumaphen or a mixture thereof.

20 **[0028]** In a preferred embodiment of the invention, the rodent control device comprises acute rodenticides, preferably bromethalin. In another preferred embodiment of the invention, anticoagulants are used as rodenticides, more preferably first or second generation anticoagulants, and most preferably, warfarin or bromadiolone.

25 **[0029]** In order to delay or prevent the development of tolerance or later resistance to the rodenticide in the rodents, various rodenticides can be used in the rodent control device according to the invention, for example, by providing different rodenticides within the same type in the solid part and in the pulpy part, or by providing different types of rodenticides in the solid part and in the pulpy part. In a preferred embodiment of the invention, the rodent control device comprises first and second generation anticoagulants, e.g., warfarin and bromadiolone.

30 **[0030]** The rodenticide ingredient in the rodent control device of the invention is dispersed in a manner that only 8% to 70% of the total permitted amount (50 ppm) is mixed into the solid bait and the remaining part, preferably 30% to 92% is used in the pulpy part. This will ensure that the rodent will rapidly consume the paraffinized solid part, but will also quickly arrive to the pulpy part because of the relatively thin walls of the holes that accommodate the pulpy part, and therefore, will consume a lethal dose of the active ingredient.

35 **[0031]** The shaped, paraffinized solid part of the rodent control device of the invention can be prepared in various forms, using any of the several known methods, preferably extrusion. Figures 1 to 6 show preferred embodiments of the invention.

#### 40 Description of the figures:

##### **[0032]**

- 45
- 50 - Figure 1 shows a rodent control device, wherein the shaped rodenticide bait (1) is an extruded block with a circle-segment cross-section, and comprising one hole (11) for accommodating the pulpy rodenticide bait and another hole (21) for fixing.
  - Figure 2 shows a rodent control device, wherein the shaped rodenticide bait (2) is an extruded block with a rectangle cross-section provided with half-circle shaped hollows, and comprising one hole (12) for accommodating the pulpy rodenticide bait and one fixing hole (21).
  - 55 - Figure 3 shows a rodent control device, wherein the shaped rodenticide bait (3) is an extruded block with a rectangle cross-section provided with trapezoid hollows on all four sides, and comprising four holes (13) for accommodating the pulpy rodenticide bait and one fixing hole (21).

## EP 2 806 735 B1

- Figure 4 shows a rodent control device, wherein the shaped rodenticide bait (4) is an extruded block with a rectangle cross-section provided with half-circle shaped hollows, and comprising four holes (14) for accommodating the pulpy rodenticide bait and one fixing hole (21).
- Figure 5 shows a rodent control device, wherein the shaped rodenticide bait (5) is an extruded block with a circular cross-section, and comprising two holes (15) for accommodating the pulpy rodenticide bait and one fixing hole (21).
- Figure 6 shows a rodent control device, wherein the shaped rodenticide bait (6) is an extruded block with a rectangle cross-section provided with wedge shaped hollows, and comprising two holes (16) for accommodating the pulpy rodenticide bait and one fixing hole (21).

**[0033]** For example, the solid part of the rodent control device according to the invention is a block with rectangular cross-section provided with hollows and with one or more holes for the pulpy bait and at least one hole for fixing.

**[0034]** The rodent control device according to the invention is preferably fixable. For example, it can be placed onto a fixing rod via the fixing hole (21), wherein the fixing rod can be placed and fixed in a closed space, e.g. in a box or a bait station. The opening of the closed space can be provided in a manner to ensure that only rodents can access the fixed rodent control device. Fixing the device in this manner is preferred because rodents cannot take it away, and it will become inaccessible for other organisms after closing the box or bait station, and this will further increase safety. Another advantage of fixing is that rodents will be unable to take the bait away and this reduces the potential for environmental pollution.

**[0035]** Consumption and efficacy studies were conducted using brown rats (*Rattus norvegicus*), i.e., the most common species, to determine whether the rodent control devices of the invention are superior to the widely accepted standard composition comprising no rodenticide (hereinafter referred to as "EPA Standard"). The results demonstrate that the consumption increases significantly, approximately by 52% in comparison with the standard composition (see Example 9), and the mortality is also expected to increase because higher rodenticide amounts will accumulate in the body of the rodents within shorter periods, and they will consequently die earlier. Thus, the rodent control device according to the invention may reduce the time required for rodents to die. Therefore, by the use of the rodent control device of the invention, elimination of the rodent populations will require less time, bait, labour-force and maintenance.

**[0036]** The rodent control device of the invention has many advantages over the known paraffinized and pulpy products, including the above-mentioned combined products:

- efficient to kill a wide range and great numbers of rodents without polluting the environment or having secondary poisoning effects;
- in comparison with the known paraffinized blocks, consumption of the device is increased, and due to the feeding habits of the rodents (the bait is fixed and cannot be taken away) it produces a higher mortality and rodents will die earlier;
- the paraffinized solid part has lower rodenticide levels than the known extruded paraffinized blocks (e.g., PROTECT extruded rodenticide block), therefore, anyone having contact with it during application will be exposed to a lower risk of poisoning;
- in order to degrade acceptance/palatability, paraffin wax is only used in the amounts necessary for solidification and plasticity;
- rodents will quickly arrive to the highly nutritious pulpy bait with greater rodenticide levels;
- since rodents cannot take the device away, consumption can be easily tracked and checked.

**[0037]** According to another aspect, the invention also relates to the preparation of the rodent control device. The method of preparing the rodent control device consists of the steps of mixing the components of the paraffinized solid bait, shaping it into the desired form using methods that are known *per se*, such as extrusion or compression, and then pressing the separately prepared pulp part into the holes of the solid part. In another method, the pulpy part is filled in during the shaping of the solid part, for example, by coextrusion. For the preparation of the pulpy part, the fats and/or oils are mixed with the active ingredient, the antioxidant and the colouring agent in a suitable mixer. Other necessary components are admixed after a short incubation period.

**[0038]** According to a third aspect, the invention also relates to the use of the rodent control device for the control of rodents, especially rats and mice. Preferably, the rodent control device of the invention can be used for the control of harmful rodents belonging to the family of murine animals (*Muridae*), such as house mouse (*Mus musculus*), steppe mouse (*Mus spicilegus*), striped field mouse (*Mus agrarius* Pall), forest mouse (*Apodemus silvatica*), and rats, such as black rat (*Rattus rattus*) and brown rat (*Rattus norvegicus*).

**[0039]** The invention is more specifically described in the following examples which are provided as illustration only and will not limit the scope of the invention in any way.

## EP 2 806 735 B1

### Example 1: Preparation of a rodent control device

#### A) Composition of the solid bait:

5 [0040]

	Component	Amount % (w/w)
	Warfarin:	0.0038 %
10	Crop milling products/flours:	62.998 %
	Sugar:	8.000 %
	Antioxidant:	0.072 %
	Flavours and aromas:	0.600 %
	Preservatives:	0.500 %
15	Denatonium benzoate:	0.002 %
	Colouring agent:	0.024 %
	Paraffin wax:	23.630 %
	Solvents:	<u>4.1702 %</u>
20		100.000 %

#### B) Composition of the pulpy part:

25 [0041]

	Component	Amount % (w/w)
	Warfarin:	0.2583 %
	Crop milling products/flours:	66.658 %
	Sugar:	4.000 %
30	Antioxidant:	0.093 %
	Flavours and aromas:	0.150 %
	Preservatives:	0.050 %
	Denatonium benzoate:	0.002 %
	Colouring agent:	0.050 %
35	Fats/oils:	25.000 %
	Solvents:	<u>3.7387 %</u>
		100.000 %

40 [0042] The rodent control device is prepared as follows: for the preparation of the solid part, from among the components listed under section A) the active ingredient is dissolved in the solvents, and then added to the mixture of the other components previously prepared in a suitable equipment, mixed to homogeneity, extruded separately and filled with the pulpy part or coextruded with the pulpy part.

45 [0043] For the preparation of the pulpy part, from among the components listed under section B) the active ingredient is dissolved in the solvents, then the fats and/or oils, the antioxidant and the colouring agent are added and mixed in a suitable mixer. Other necessary components are admixed after a short incubation period. However, the amount of both A) and B) are selected to ensure 86.6% (w/w) solid part and 13.4% (w/w) pulpy part in the rodent control device (with a total weight of 100%). The combined overall concentration of the rodenticide ingredient in the solid part and in the pulpy part is 0.038% (w/w).

50

### Example 2: Preparation of a rodent control device

#### A) Composition of the solid bait:

55 [0044]

## EP 2 806 735 B1

	<b>Component</b>	<b>Amount % (w/w)</b>
	Warfarin:	0.030 %
	Crop milling products/flours:	62.998 %
5	Sugar:	8.000 %
	Antioxidant:	0.072 %
	Flavours and aromas:	0.600 %
	Preservatives:	0.500 %
	Denatonium benzoate:	0.002 %
10	Colouring agent:	0.024 %
	Paraffin wax:	23.630 %
	Solvents:	<u>4.144 %</u>
		100.000%

### 15 B) Composition of the pulpy part:

[0045]

	<b>Component</b>	<b>Amount % (w/w)</b>
20	Warfarin:	0.0895 %
	Crop milling products/flours:	66.658 %
	Sugar:	4.000 %
	Antioxidant:	0.093 %
25	Flavours and aromas:	0.150 %
	Preservatives:	0.050 %
	Denatonium benzoate:	0.002 %
	Colouring agent:	0.050 %
30	Fats/oils:	25.000 %
	Solvents:	<u>3.9075 %</u>
		100.000%

35 [0046] The method of preparing the rodent control device is exactly the same as described in Example 1. The amount of both A) and B) are selected to ensure 86.6% (w/w) solid part and 13.4% (w/w) pulpy part in the rodent control device (with a total weight of 100%). The combined overall concentration of the rodenticide ingredient is 0.038% (w/w).

### Example 3: Preparation of a rodent control device

#### 40 A) Composition of the solid bait:

[0047]

	<b>Component</b>	<b>Amount % (w/w)</b>
45	Bromadiolone:	0.0005 %
	Crop milling products/flours:	62.998 %
	Sugar:	8.000 %
	Antioxidant:	0.072 %
50	Flavours and aromas:	0.600 %
	Preservatives:	0.500 %
	Denatonium benzoate:	0.002 %
	Colouring agent:	0.024 %
	Paraffin wax:	23.630 %
55	Solvents:	<u>4.1735 %</u>
		100.000 %

## EP 2 806 735 B1

### B) Composition of the pulpy part:

[0048]

	Component	Amount % (w/w)
5	Bromadiolone:	0.034 %
	Crop milling products/flours:	66.658 %
	Sugar:	4.000 %
10	Antioxidant:	0.093 %
	Flavours and aromas:	0.150 %
	Preservatives:	0.050 %
	Denatonium benzoate:	0.002 %
	Colouring agent:	0.050 %
15	Fats/oils:	25.000 %
	Solvents:	<u>3.963 %</u>
		100.000 %

20 [0049] The method of preparing the rodent control device is exactly the same as described in Example 1. The amount of both A) and B) are selected to ensure 86.6% (w/w) solid part and 13.4% (w/w) pulpy part in the rodent control device (with a total weight of 100%). The combined overall concentration of the rodenticide ingredient is 0.005% (w/w).

### Example 4: Preparation of a rodent control device

25

#### A) Composition of the solid bait:

[0050]

	Component	Amount % (w/w)
30	Bromadiolone:	0.004 %
	Crop milling products/flours:	62.998 %
	Sugar:	8.000 %
	Antioxidant:	0.072 %
35	Flavours and aromas:	0.600 %
	Preservatives:	0.500 %
	Denatonium benzoate:	0.002 %
	Colouring agent:	0.024 %
40	Paraffin wax:	23.630 %
	Solvents:	<u>4.170 %</u>
		100.000 %

#### B) Composition of the pulpy part:

45

[0051]

	Component	Amount % (w/w)
50	Bromadiolone:	0.0114 %
	Crop milling products/flours:	66.658 %
	Sugar:	4.000 %
	Antioxidant:	0.093 %
	Flavours and aromas:	0.150 %
55	Preservatives:	0.050 %
	Denatonium benzoate:	0.002 %
	Colouring agent:	0.050 %

## EP 2 806 735 B1

(continued)

	<b>Component</b>	<b>Amount % (w/w)</b>
5	Fats/oils:	25.000 %
	Solvents:	<u>3.9856 %</u>
		100.000 %

10 **[0052]** The method of preparing the rodent control device is exactly the same as described in Example 1. The amount of both A) and B) are selected to ensure 86.6% (w/w) solid part and 13.4% (w/w) pulpy part. The combined overall concentration of the rodenticide ingredient is 0.005% (w/w).

### Example 5: Preparation of a rodent control device

#### 15 **A) Composition of the solid bait:**

**[0053]**

	<b>Component</b>	<b>Amount % (w/w)</b>
20	Bromadiolone:	0.003 %
	Crop milling products/flours:	62.998 %
	Sugar:	8.000 %
	Antioxidant:	0.072 %
	Flavours and aromas:	0.600 %
25	Preservatives:	0.500 %
	Denatonium benzoate:	0.002 %
	Colouring agent:	0.024 %
	Paraffin wax:	23.630 %
30	Solvents:	<u>4.171 %</u>
		100.000 %

#### **B) Composition of the pulpy part:**

35 **[0054]**

	<b>Component</b>	<b>Amount % (w/w)</b>
	Bromadiolone:	0.0098 %
40	Crop milling products/flours:	66.658 %
	Sugar:	4.000 %
	Antioxidant:	0.093 %
	Flavours and aromas:	0.150 %
	Preservatives:	0.050 %
45	Denatonium benzoate:	0.002 %
	Colouring agent:	0.050 %
	Fats/oils:	25.000 %
	Solvents:	<u>3.9872 %</u>
50		100.000%

55 **[0055]** The method of preparing the rodent control device is exactly the same as described in Example 1. The amount of both A) and B) are selected to ensure 70.5% (w/w) solid part and 29.5% (w/w) pulpy part. The combined overall concentration of the rodenticide ingredient is 0.005% (w/w).

## EP 2 806 735 B1

### Example 6: Preparation of a rodent control device

#### A) Composition of the solid bait:

5 [0056]

	Component	Amount % (w/w)
	Bromadiolone:	0.005 %
10	Crop milling products/flours:	62.998 %
	Sugar:	8.000 %
	Antioxidant:	0.072 %
	Flavours and aromas:	0.600 %
	Preservatives:	0.500 %
15	Denatonium benzoate:	0.002 %
	Colouring agent:	0.024 %
	Paraffin wax:	23.630 %
	Solvents:	<u>4.169 %</u>
20		100.000 %

#### B) Composition of the pulpy part:

25 [0057]

	Component	Amount % (w/w)
	Bromadiolone:	0.005 %
	Crop milling products/flours:	66.658 %
	Sugar:	4.000 %
30	Antioxidant:	0.093 %
	Flavours and aromas:	0.150 %
	Preservatives:	0.050 %
	Denatonium benzoate:	0.002 %
	Colouring agent:	0.050 %
35	Fats/oils:	25.000 %
	Solvents:	<u>3.992 %</u>
40		100.000 %

[0058] The method of preparing the rodent control device is exactly the same as described in Example 1. The amount of both A) and B) are selected to ensure 86.6% (w/w) solid part and 13.4% (w/w) pulpy part in the rodent control device. The combined overall concentration of the rodenticide ingredient is 0.005% (w/w).

### Example 7: Preparation of a rodent control device

#### A) Composition of the solid bait:

50 [0059]

	Component	Amount % (w/w)
	Bromethalin:	0.001 %
	Crop milling products/flours:	62.998 %
	Sugar:	8.000 %
55	Antioxidant:	0.072 %
	Flavours and aromas:	0.600 %
	Preservatives:	0.500 %

## EP 2 806 735 B1

(continued)

	<b>Component</b>	<b>Amount % (w/w)</b>
5	Denatonium benzoate:	0.002 %
	Colouring agent:	0.024 %
	Paraffin wax:	23.630 %
	Solvents:	<u>4.173 %</u>
		100.000 %

### 10 B) Composition of the pulpy part:

#### [0060]

	<b>Component</b>	<b>Amount % (w/w)</b>
15	Bromethalin:	0.068 %
	Crop milling products/flours:	66.658 %
	Sugar:	4.000 %
	Antioxidant:	0.093 %
20	Flavours and aromas:	0.150 %
	Preservatives:	0.050 %
	Denatonium benzoate:	0.002 %
	Colouring agent:	0.050 %
	Fats/oils:	25.000 %
25	Solvents:	<u>3.881 %</u>
		100.000%

30 [0061] The method of preparing the rodent control device is exactly the same as described in Example 1. The amount of both A) and B) are selected to ensure 86.6% (w/w) solid part and 13.4% (w/w) pulpy part in the rodent control device. The combined overall concentration of the rodenticide ingredient is 0.01% (w/w).

### Example 8: Preparation of a rodent control device

#### 35 A) Composition of the solid bait:

#### [0062]

	<b>Component</b>	<b>Amount % (w/w)</b>
40	Bromethalin:	0.009 %
	Crop milling products/flours:	62.998 %
	Sugar:	8.000 %
	Antioxidant:	0.072 %
45	Flavours and aromas:	0.600 %
	Preservatives:	0.500 %
	Denatonium benzoate:	0.002 %
	Colouring agent:	0.024 %
	Paraffin wax:	23.630 %
50	Solvents:	<u>4.165 %</u>
		100.000%

#### B) Composition of the pulpy part:

#### 55 [0063]

## EP 2 806 735 B1

	<b>Component</b>	<b>Amount % (w/w)</b>
	Bromethalin:	0.0164 %
	Crop milling products/flours:	66.658 %
5	Sugar:	4.000 %
	Antioxidant:	0.093 %
	Flavours and aromas:	0.150%
	Preservatives:	0.050 %
	Denatonium benzoate:	0.002 %
10	Colouring agent:	0.050 %
	Fats/oils:	25.000 %
	Solvents:	<u>3.9806 %</u>
		100.000%

15 **[0064]** The method of preparing of the rodent control device is exactly the same as described in Example 1. The amount of both A) and B) are selected to ensure 86.6% (w/w) solid part and 13.4% (w/w) pulpy part in the rodent control device. The combined overall concentration of the rodenticide ingredient is 0.01% (w/w).

### 20 **Example 9: Preparation of a rodent control device**

#### **A) Composition of the solid bait:**

**[0065]**

	<b>Component</b>	<b>Amount % (w/w)</b>
	Bromadiolone:	0.0025 %
	Crop milling products/flours:	62.998 %
	Sugar:	8.000 %
30	Antioxidant:	0.072 %
	Flavours and aromas:	0.600 %
	Preservatives:	0.500 %
	Denatonium benzoate:	0.002 %
	Colouring agent:	0.024 %
35	Paraffin wax:	23.630 %
	Solvents:	<u>4.1715 %</u>
		100.000%

#### 40 **B) Composition of the pulpy part:**

**[0066]**

	<b>Component</b>	<b>Amount % (w/w)</b>
	Warfarin:	0.076 %
	Crop milling products/flours:	66.658 %
	Sugar:	4.000 %
	Antioxidant:	0.093 %
50	Flavours and aromas:	0.150 %
	Preservatives:	0.050 %
	Denatonium benzoate:	0.002 %
	Colouring agent:	0.050 %
	Fats/oils:	25.000 %
55	Solvents:	<u>3.921 %</u>
		100.000 %

[0067] The method of preparing the rodent control device is exactly the same as described in Example 1. The amount of both A) and B) are selected to ensure 86.6% (w/w) solid part and 13.4% (w/w) pulpy part in the rodent control device. The concentration of the second generation rodenticide ingredient in the solid part is 0.003% (w/w), and the concentration of the first generation rodenticide ingredient in the pulpy part is 0.076% (w/w).

#### Example 10: Palatability (consumption) studies

[0068] Palatability studies were conducted with the rodent control device of the invention in comparison with the US EPA Standard (EPA: United States Environmental Protection Agency), which basically comprises crushed/milled crops (oat, corn) supplemented with sugar and edible oil, and no active ingredients. The studies were in compliance with the current guidelines and the habituation and pre-feeding periods were also observed.

[0069] Each study involved 5 male and 5 female, mature, healthy brown rats (*Rattus norvegicus*). Each rodent was accommodated separately in a 225 x 265 x 180 mm LF-3H type Amkrolon cage with a surface area of 800 mm<sup>2</sup>. During the entire study, the temperature was set to 20°C to 25°C and the relative humidity to 45% to 50%, and the rodents were exposed to 12/12 hour dark/light periods. During the study, water was provided *ad libitum*.

[0070] After a three-day conditioning period, study rodents were given the usual CRLT/N laboratory feed (manufacturer: Bioplan Kft., Hungary) *ad libitum*. Two steel feeding containers were attached to both sides of the front of the cage; the first was filled with the experimental rodenticide product, and the second with the standard EPA feed. Three studies were conducted: in the first and second study the extruded solid part and the pulpy part were tested separately, while in the third one the combined rodent control device of the invention prepared according to Example 4 and containing 0.005% bromadiolone was investigated.

Both feeding containers were weighed and filled with the rodenticide product, in an amount sufficient for the daily needs of the rats. After 24 hours, both feeding containers (plus the spilled feed) were weighed again and the total amount of the rodenticide product consumed by each rat was calculated. This was repeated for five consecutive days and the results were averaged.

[0071] The following results were obtained: on average, the consumption rate of the paraffinized blocks having the same composition as the solid part of the claimed rodent control device was 33.65% in comparison with the average consumption rate of the EPA Standard (66.35%). On average, the consumption rate for the bait having the same composition as the pulpy part of the claimed rodent control device was 33.60% in comparison with the average consumption rate of the EPA Standard (66.40%). In case of the combined product according to the invention, the consumption rate increased to 55.4%, while the consumption of the EPA Standard decreased to 44.6%.

[0072] The initial high consumption rates of the EPA Standard are due to its better taste, and the absence of paraffin, colouring agents, active ingredients, repellents, preservatives etc. Rodents consumed the pulpy part at the same rate as the solid part which may be due to the fact that the solid part of the claimed rodent control device is also sufficiently attractive, and that the pulpy part used in the studies was less acceptable than average because of the uneven quality of the mostly food-like raw materials used for its production.

In case of rodenticide baits, the approximately 33% consumption rate in comparison with the EA Standard is a very good result considering the 20% lower acceptance/palatability limit, although lower acceptance/palatability can also be convenient provided that the mortality is 100% in the end of the study. The data clearly demonstrate that rodents preferred the combination according to the invention over the EPA Standard and this is the reason for the reduction in the consumption of the EPA Standard in the third study. This may be due to the fact that in contrast with the monotonous EPA feed, the combined bait offers variability via the pulpy and solid part.

The mortality was 100% in all of the above mentioned studies.

#### Claims

1. A rodent control device, which is a combination of solid and pulpy rodenticide baits **characterised in that** the solid part having lower rodenticide concentration than that of the combination is a shaped paraffinized block rodenticide bait with at least one hole for containing the pulp, the pulpy part having higher rodenticide concentration than that of the combination is contained within said hole of block rodenticide bait.
2. A rodent control device, which is a combination of solid and pulpy rodenticide baits **characterised in that** the solid part having equal rodenticide concentration to that of the combination is a shaped paraffinized block rodenticide bait with at least one hole for containing the pulp, the pulpy part having equal rodenticide concentration to that of the combination is contained within said hole of block bait.
3. The rodent control device according to claims 1 or 2, **characterised in that** the solid part having a rodenticide

## EP 2 806 735 B1

concentration lower than or equal to that of the combination is a shaped paraffinized block rodenticide bait (1, 2, 3, 4, 5, 6) with one hole (11, 12) or more holes (13, 14, 15, 16), the pulpy part having a rodenticide concentration higher than or equal to that of the combination is contained within said hole(s), wherein the percentage rate of the solid part is 70-90 and the percentage rate of the pulpy part is 10-30 compared to the total mass of device.

- 5
4. The rodent control device according to any one of claims 1 to 3, **characterised in that** the rodenticide in both the solid and the pulpy part is an acute rodenticide such as scilliroside, strychnine, crimidine, bromethalin, sodium fluoroacetate, fluoroacetamide, zinc phosphide, norbormide, thallium sulphate, alpha-chloralose and alpha-naphthylthiourea or a mixture thereof.
- 10
5. The rodent control device according to any one of claims 1 to 3, **characterised in that** the rodenticide in both the solid and the pulpy part is a chronic rodenticide.
- 15
6. The rodent control device according to claim 5, **characterised in that** the chronic rodenticide is a first generation anticoagulant such as warfarin, warfarin sodium, coumachlor, coumatetralyl, coumafuryl, pivaldione, diphacinone, chlorophacinone or a mixture thereof.
- 20
7. The rodent control device according to claim 5, **characterised in that** the chronic rodenticide is a second generation anticoagulant such as bromadiolone, diphenacoum, brodifacoum, difethialone and flocoumaphen or a mixture thereof.
- 25
8. The rodent control device according to any one of claims 1 to 3, **characterised in that** the rodenticides in the solid and the pulpy part are different.
- 30
9. The rodent control device according to claim 8, **characterised in that** the different chronic rodenticides are first generation and second generation anticoagulants.
- 35
10. The rodent control device according to any one of claims 1 to 9, **characterised in that** the shaped rodenticide bait (1, 2, 3, 4, 5, 6) comprises a fixing hole (21).
- 40
11. The rodent control device according to any one of claims 1 to 9, **characterised in that** the shaped rodenticide bait (2, 3, 6) is an extruded block with a rectangular cross-section comprising at least one hole (12, 13, 16) for containing the pulpy rodenticide bait.
- 45
12. A method for the preparation of the rodent control device according to any one of claims 1 to 11, comprising the steps of:
- 50
- (i) preparing the solid bait with at least one hole for containing the pulp, using paraffin wax, the rodenticide and the other necessary components, in a manner which is known *per se*, preferably by extrusion;
  - (ii) preparing the pulpy bait using the necessary components and the rodenticide, in a manner which is known *per se*; and
  - (iii) filling part or the whole of at least one hole in the solid part with the pulpy bait during or after the preparation of the solid part, preferably by coextrusion.
- 55
13. Use of the device according to any one of claims 1 to 11 or prepared according to the method of claim 12, for the control of rodents.
14. The use according to claim 13 for the control of rodents belonging to the family of murine animals (*Muridae*), such as house mouse (*Mus musculus*), steppe mouse (*Mus spicilegas*), striped field mouse (*Mus agrarius* Pall), black rat (*Rattus rattus*), brown rat (*Rattus norvegicus*) or other rodents.
15. The use according to claim 14, wherein the rodent is black rat or brown rat.

### 55 Patentansprüche

1. Eine Vorrichtung zur Nagetierbekämpfung, die eine Kombination aus festen und breiigen Rodentizid-Ködern ist, **dadurch gekennzeichnet, dass** der eine geringere Rodentizidkonzentration als die Kombination aufweisende

## EP 2 806 735 B1

solide Teil ein geformter, paraffinierter Rodentizidköderblock mit mindestens einem Loch zur Aufnahme des Breis ist, wobei der breiige, eine höhere Rodentizidkonzentration als die der Kombination aufweisende Teil in dem besagten Lochs des Rodentizidköderblocks enthalten ist.

- 5 2. Eine Vorrichtung zur Nagetierbekämpfung, die eine Kombination aus festen und breiigen Rodentizid-Ködern ist, **dadurch gekennzeichnet, dass** der eine identische Rodentizidkonzentration als die Kombination aufweisende solide Teil ein geformter, paraffinierter Rodentizidköderblock mit mindestens einem Loch zur Aufnahme des Breis ist, wobei der breiige, eine identische Rodentizidkonzentration als die der Kombination aufweisende Teil in dem besagten Loch des Rodentizidköderblocks enthalten ist.
- 10 3. Die Vorrichtung zur Nagetierbekämpfung gemäß Anspruch 1 oder 2, **dadurch gekennzeichnet, dass** der, eine geringere oder gleiche Rodentizidkonzentration als die Kombination aufweisende solide Teil ein geformter, paraffinierter Rodentizidköderblock (1, 2, 3, 4, 5, 6) mit einem Loch (11, 12) oder mehreren Löchern (13, 14, 15, 16) ist, dass der breiige, eine höhere oder gleiche Rodentizidkonzentration als die der Kombination aufweisende Teil in dem besagten Loch oder in den besagten Löchern des Rodentizidköderblocks enthalten ist, wobei das prozentuale Verhältnis des soliden Teils bei 70-90 und das prozentuale Verhältnis des breiigen Teils bei 10-30 im Vergleich zur Gesamtmasse der Vorrichtung liegt.
- 15 4. Die Vorrichtung zur Nagetierbekämpfung gemäß einem der vorstehenden Ansprüche 1 bis 3, **dadurch gekennzeichnet, dass** das Rodentizid im soliden und im breiigen Teil ein akutes Rodentizid ist, wie Scillirosid, Strychnin, Crimidin, Bromethalin, Natrium-Fluoracetat, Fluoracetamid, Zinkphosphid, Norbormid, Thalliumsulfat, Alpha-Chloralose und Alpha-Naphthyltioharnstoff oder ein Gemisch daraus ist,
- 20 5. Die Vorrichtung zur Nagetierbekämpfung gemäß einem der vorstehenden Ansprüche 1 bis 3, **dadurch gekennzeichnet, dass** das Rodentizid im soliden und im breiigen Teil ein chronisches Rodentizid ist.
- 25 6. Die Vorrichtung zur Nagetierbekämpfung gemäß Anspruch 5, **dadurch gekennzeichnet, dass** besagtes chronische Rodentizid ein Antikoagulant der ersten Generation ist, wie Warfarin, Warfarinnatrium, Coumachlor, Coumatetralyl, Coumafuryl, Pivaldion, Diphacinon, Chlorphacinon oder ein Gemisch daraus ist.
- 30 7. Die Vorrichtung zur Nagetierbekämpfung gemäß Anspruch 5, **dadurch gekennzeichnet, dass** das chronische Rodentizid ein Antikoagulant der zweiten Generation ist, wie Bromadiolon, Diphenacum, Brodifacoum, Difethioalon und Flocoumafen oder ein Gemisch daraus.
- 35 8. Die Vorrichtung zur Nagetierbekämpfung gemäß einem der vorstehenden Ansprüche 1 bis 3, **dadurch gekennzeichnet, dass** die Rodentizide im soliden und im breiigen Teil unterschiedlich sind.
- 40 9. Die Vorrichtung zur Nagetierbekämpfung gemäß Anspruch 8, **dadurch gekennzeichnet, dass** die verschiedenen Rodentizide Antikoagulanten der ersten und zweiten Generation sind.
- 45 10. Die Vorrichtung zur Nagetierbekämpfung gemäß einem der vorstehenden Ansprüche 1 bis 9, **dadurch gekennzeichnet, dass** der geformte Rodentizidköder (1, 2, 3, 4, 5, 6) ein Befestigungsloch (21) umfasst
- 50 11. Die Vorrichtung zur Nagetierbekämpfung gemäß einem der vorstehenden Ansprüche 1 bis 9, **dadurch gekennzeichnet, dass** der geformte Rodentizidköder (2, 3, 6) ein extrudierter Block eines rechteckigen Querschnitts ist, der mindestens ein Loch (12, 13, 16) zur Ausnahme des breiigen Rodentizidköders umfasst.
- 55 12. Ein Verfahren zur Zubereitung der Vorrichtung zur Nagetierbekämpfung gemäß einem der vorstehenden Ansprüche 1 bis 11, **dadurch gekennzeichnet, dass** sie folgende Schritte umfasst:
- (i) Zubereitung des soliden Köders mit mindestens einem Loch zur Aufnahme des Breis, wobei Paraffinwachs, Rodentizid und die anderen notwendigen Komponenten in einer *per se* bekannten Weise, bevorzugterweise durch Extrusion verwendet werden;
  - (ii) Zubereitung des Breiköders, indem die notwendigen Komponenten und das Rodentizid in einer *per se* bekannten Weise verwendet werden;
  - (iii) Auffüllen eines Teils oder des ganzen mindestens einen Lochs im soliden Teil mit einem breiigen Köder, während oder nach der Zubereitung des soliden Teils, vorzugsweise durch Extrusion.

## EP 2 806 735 B1

13. Verwendung der Vorrichtung gemäß einem der Ansprüche 1 bis 11, oder gemäß dem Verfahren aus Anspruch 12 zubereiteten Weise zur Nagetierbekämpfung.

14. Die Verwendung gemäß Anspruch 13 zur Nagetierbekämpfung der folgenden Familien: Muridae, wie *Mus Muculus* (Hausmaus), *Mus Spicilegas* (Steppenmaus), *Mus agrarius* Pall (gestreifte Landmaus), *Rattus Rattus* (schwarze Ratte), *Rattus Norvegicus* (braune Ratte) oder andere Nagetiere.

15. Die Verwendung gemäß Anspruch 14, wo das Nagetier die schwarze oder die braune Ratte ist.

### Revendications

1. Dispositif de lutte contre les rongeurs, qui est une combinaison d'appâts rodenticides solide et pulpeux, **caractérisé en ce que** la partie solide, ayant une concentration de rodenticide inférieure à celle de la combinaison, est un appât rodenticide sous forme de bloc paraffiné avec au moins un trou pour contenir la pulpe, la partie pulpeuse, ayant une concentration de rodenticide supérieure à celle de la combinaison, est contenue à l'intérieur dudit trou d'appât rodenticide en bloc.

2. Dispositif de lutte contre les rongeurs, qui est une combinaison d'appâts rodenticides solide et pulpeux, **caractérisé en ce que** la partie solide, ayant une concentration de rodenticide égale à celle de la combinaison, est un appât rodenticide sous forme de bloc paraffiné avec au moins un trou pour contenir la pulpe, la partie pulpeuse, ayant une concentration de rodenticide égale à celle de la combinaison, est contenue à l'intérieur dudit trou d'appât en bloc.

3. Dispositif de lutte contre les rongeurs selon les revendications 1 ou 2, **caractérisé en ce que** la partie solide, ayant une concentration de rodenticide inférieure ou égale à celle de la combinaison, est un appât rodenticide sous forme de bloc paraffiné (1, 2, 3, 4, 5, 6) avec un trou (11, 12) ou plusieurs trous (13, 14, 15, 16), la partie pulpeuse, ayant une concentration de rodenticide supérieure ou égale à celle de la combinaison, est contenue à l'intérieur du ou desdits trou(s), dans lequel la valeur en pourcentage de la partie solide est de 70 à 90 et la valeur en pourcentage de la partie pulpeuse est de 30 à 10 en comparaison à la masse totale du dispositif.

4. Dispositif de lutte contre les rongeurs selon l'une quelconque des revendications 1 à 3, caractérisé dans cela le rodenticide tant dans la partie solide que pulpeuse est un rodenticide aigu comme le scilliroside, la strychnine, la crimidine, la brométhaline, le fluoroacétate de sodium, le fluoroacétamide, le phosphore de zinc, le nobormide, le sulfate de thallium, l'alpha-chloralose et l'alpha-naphthylthiourée ou un mélange de ceux-ci.

5. Dispositif de lutte contre les rongeurs selon l'une quelconque des revendications 1 à 3, **caractérisé en ce que** le rodenticide dans la partie tant solide que pulpeuse est un rodenticide chronique.

6. Dispositif de lutte contre les rongeurs selon la revendication 5, **caractérisé en ce que** le rodenticide chronique est un anticoagulant de première génération comme la warfarine, le sodium de warfarine, le coumachlore, le coumatétralyl, le coumafuryl, le pivaldione, la diphacinone, le chlorophacinone ou un mélange de ceux-ci.

7. Dispositif de lutte contre les rongeurs selon la revendication 5, **caractérisé en ce que** le rodenticide chronique est un anticoagulant de seconde génération comme le bromadiolone, le difénacoum, le brodifacoum, la diféthialone et le flocoumafène ou un mélange de ceux-ci.

8. Dispositif de lutte contre les rongeurs selon l'une quelconque des revendications 1 à 3, **caractérisé en ce que** les rodenticides dans la partie solide et dans la partie pulpeuse sont différents.

9. Dispositif de lutte contre les rongeurs selon la revendication 8, **caractérisé en ce que** les rodenticides chroniques différents sont des anticoagulants de première génération et de seconde génération.

10. Dispositif de lutte contre les rongeurs selon l'une quelconque des revendications 1 à 9, **caractérisé en ce que** l'appât rodenticide mis en forme (1, 2, 3, 4, 5, 6) comprend un trou de fixation (21).

11. Dispositif de lutte contre les rongeurs selon l'une quelconque des revendications 1 à 9, **caractérisé en ce que** l'appât rodenticide mis en forme (2, 3, 6) est un bloc extrudé avec une section transversale rectangulaire comprenant au moins un trou (12, 13, 16) pour contenir l'appât rodenticide pulpeux.

## EP 2 806 735 B1

12. Procédé pour la préparation du dispositif de lutte contre les rongeurs selon l'une quelconque des revendications 1 à 11, comprenant les étapes de:

5 (i) préparation de l'appât solide avec au moins un trou pour contenir la pulpe, en utilisant de la cire de paraffine, le rodenticide et les autres composants nécessaires, d'une façon qui est connue *en soi*, de préférence par extrusion;

(ii) préparation de l'appât pulpeux en utilisant les composants nécessaires et le rodenticide, d'une façon qui est connue *en soi*; et

10 (iii) remplissage d'une partie ou de la totalité d'au moins un trou dans la partie solide avec l'appât pulpeux pendant ou après la préparation de la partie solide, de préférence par coextrusion.

13. Utilisation du dispositif selon l'une quelconque des revendications 1 à 11 ou préparé selon le procédé de la revendication 12, pour la lutte contre les rongeurs.

15 14. Utilisation selon la revendication 13 pour la lutte contre les rongeurs appartenant à la famille des animaux murins (*Muridae*), comme la souris domestique (*Mus musculus*), la souris glaneuse (*Mus spicilegus*), le mulot rays (*Mus agrarius Pali*), le rat des greniers (*Rattus rattus*), le rat d'égout (*Rattus norvegicus*) ou d'autres rongeurs.

20 15. Utilisation selon la revendication 14, dans lequel le rongeur est le rat des greniers ou le rat d'égout,

25

30

35

40

45

50

55

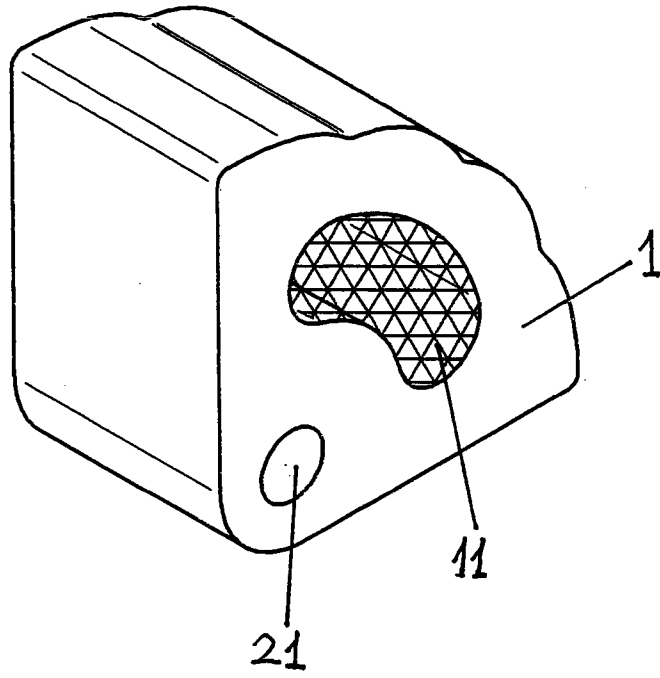

Fig. 1

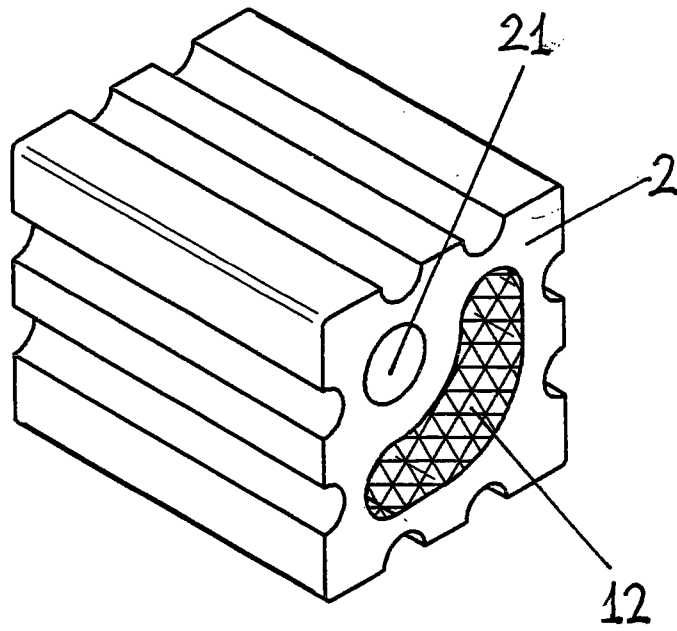

Fig. 2

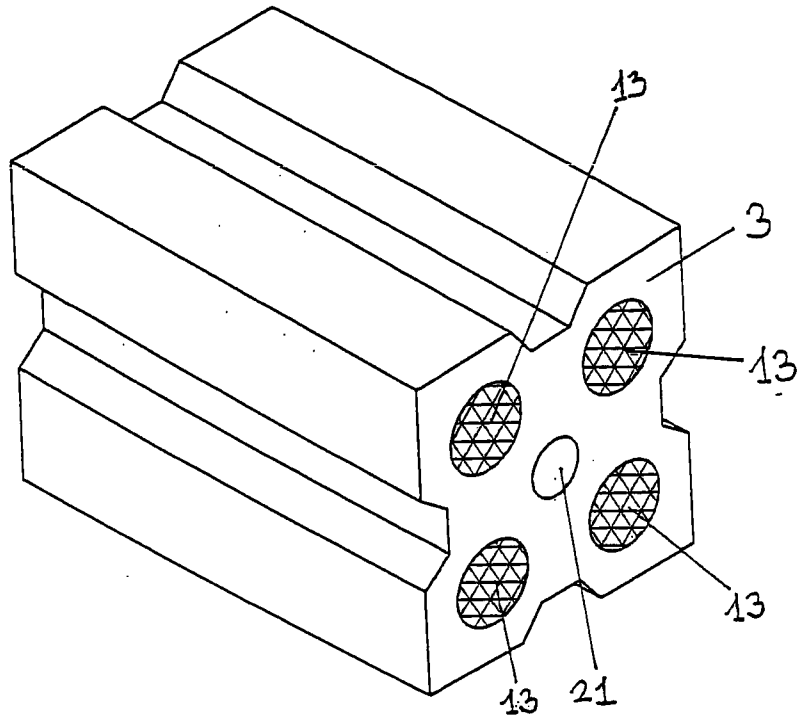

Fig. 3

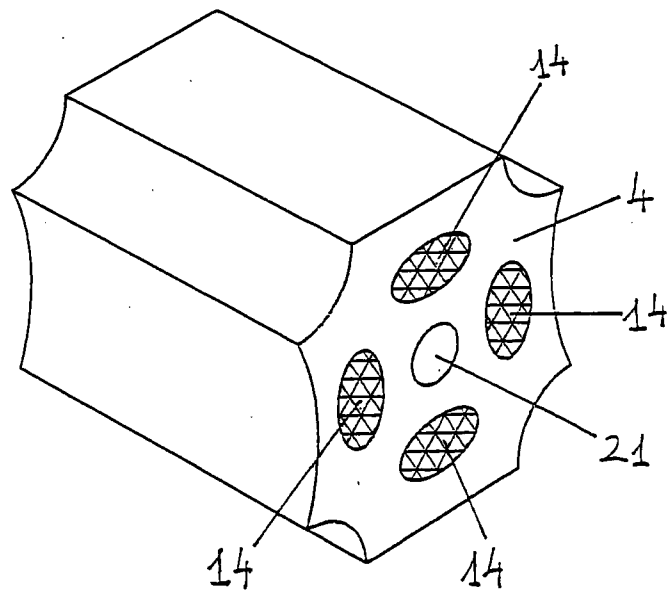

Fig. 4

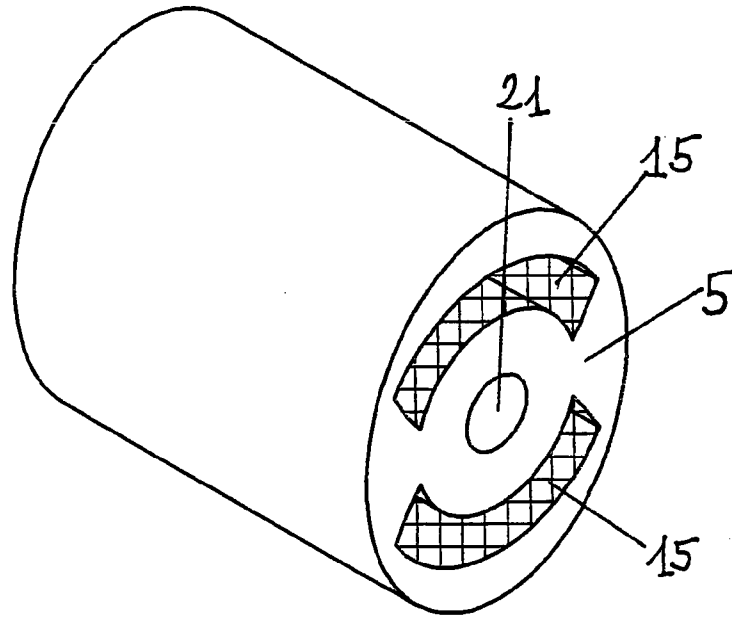

Fig. 5

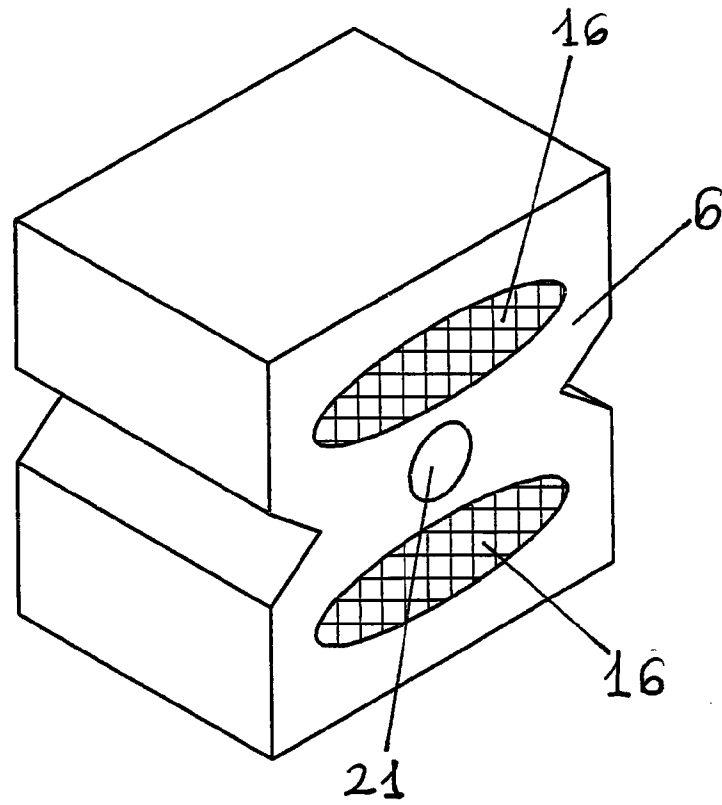

Fig. 6

**REFERENCES CITED IN THE DESCRIPTION**

*This list of references cited by the applicant is for the reader's convenience only. It does not form part of the European patent document. Even though great care has been taken in compiling the references, errors or omissions cannot be excluded and the EPO disclaims all liability in this regard.*

**Patent documents cited in the description**

- EP 0599755 A1 [0004]
- EP 1149530 A2 [0004]
- WO 99018780 A [0004]
- BE 904052 [0008]
- BE 904203 [0008]
- US 4891218 A [0009]
- EP 2090164 A1 [0012]
- EP 1279334 A [0013] [0024]

## Rágcsálóirtó eszköz

### SZABADALMI IGÉNYPONTOK

1. Rágcsálóirtó eszköz, amely szilárd és pépes rágcsálóirtó csalétek kombinációja, **azzal jellemezve, hogy** a szilárd rész egy formázott, a kombináció rodenticid-koncentrációjánál kisebb rodenticid-koncentrációjú, paraffint tartalmazó, olyan rágcsálóirtó csalétek, amely rendelkezik legalább egy üreggel a pép befogadására, a pépes rész pedig, amely a kombináció rodenticid-koncentrációjánál nagyobb rodenticid-koncentrációjú, a rágcsálóirtó csalétek-tömb üregébe van belefoglalva.

2. Rágcsálóirtó eszköz, amely szilárd és pépes rágcsálóirtó csalétek kombinációja, **azzal jellemezve, hogy** a szilárd rész egy formázott, a kombináció rodenticid-koncentrációjával egyenlő rodenticid-koncentrációjú, paraffint tartalmazó, olyan rágcsálóirtó csalétek, amely rendelkezik legalább egy üreggel a pép befogadására, a pépes rész pedig, amely a kombináció rodenticid-koncentrációjával egyenlő rodenticid-koncentrációjú, a csalétek-tömb üregébe van belefoglalva.

3. Az 1. vagy 2. igénypont szerinti rágcsálóirtó eszköz, **azzal jellemezve, hogy** a szilárd rész egy formázott, a kombináció rodenticid-koncentrációjánál kisebb vagy azzal egyenlő rodenticid-koncentrációjú, paraffint tartalmazó, olyan rágcsálóirtó csalétek (1, 2, 3, 4, 5, 6), amely rendelkezik egy üreggel (11, 12) vagy több üreggel (13, 14, 15, 16), a pépes rész pedig, amely a kombináció rodenticid-koncentrációjánál nagyobb vagy azzal egyenlő rodenticid-koncentrációjú, az üreg(ek)be van belefoglalva, ahol az eszköz össztömegére vonatkoztatva a szilárd rész százalékos aránya 70-90, a pépes rész százalékos aránya pedig 10-30.

4. Az 1-3. igénypontok bármelyike szerinti rágcsálóirtó eszköz, **azzal jellemezve, hogy** a rodenticid mind a szilárd mind a pépes részben egy akut rodenticid, úgy mint szcillirozid, sztrichnin, crimidin, brómetalin, nátrium-fluor-acetát, fluor-aceta-

mid, cink-foszfid, norbormid, tallium-szulfát, alfa-kloralóz és alfa-naftil-tiokarbamid vagy ezek keveréke.

5. Az 1-3. igénypontok bármelyike szerinti rágcsálóirtó eszköz, **azzal jellemezve, hogy** a rodenticid mind a szilárd mind a pépes részben egy krónikus hatású rodenticid.

6. Az 5. igénypont szerinti rágcsálóirtó eszköz, **azzal jellemezve, hogy** a krónikus hatású rodenticid egy első generációs véralvadásgátló, úgy mint warfarin, warfarin-nátrium, kumaklór, kumatetralil, kumafuril, pivaldion, difacinon, klórfacinon vagy ezek keveréke.

7. Az 5. igénypont szerinti rágcsálóirtó eszköz, **azzal jellemezve, hogy** a krónikus hatású rodenticid egy második generációs véralvadásgátló, úgy mint bromadiolon, difenakum, brodifakum, difetialon és flokumafen vagy ezek keveréke.

8. Az 1-3. igénypontok bármelyike szerinti rágcsálóirtó eszköz, **azzal jellemezve, hogy** a rodenticidek a szilárd és a pépes részben egymástól eltérnek.

9. A 8. igénypont szerinti rágcsálóirtó eszköz, **azzal jellemezve, hogy** az eltérő krónikus hatású rodenticidek első generációs és második generációs véralvadásgátlók.

10. Az 1-9. igénypontok bármelyike szerinti rágcsálóirtó eszköz, **azzal jellemezve, hogy** a formázott rágcsálóirtó csalétek (1, 2, 3, 4, 5, 6) egy rögzítő üreget (21) tartalmaz.

11. Az 1-9. igénypontok bármelyike szerinti rágcsálóirtó eszköz, **azzal jellemezve, hogy** a formázott rágcsálóirtó csalétek (2, 3, 6) extrudált, négyszög keresztmetszetű tömbként van kialakítva, amely legalább egy, a pépes rágcsálóirtó csalétek befogadására szolgáló üreget (12, 13, 16) foglal magába.

12. Eljárás az 1-11. igénypontok bármelyike szerinti rágcsálóirtó eszköz előállítására, amely a következő lépéseket foglalja magába:

(i) a szilárd csalétek elkészítése legalább egy pépet befogadó üreggel paraffinból, rodenticidből és a szükséges egyéb komponensekből önmagában ismert módon, előnyösen extrudálással;

(ii) a pépes csalétek elkészítése a szükséges komponensekből és rodenticidből önmagában ismert módon; és

(iii) a szilárd rész legalább egy üregének feltöltése részben vagy egészben a pépes csalétekkel, a szilárd rész elkészítése után vagy azzal egy időben, előnyösen koextrudálással.

**13.** Az 1-11. igénypontok bármelyike szerinti vagy a 12. igénypont szerinti eljárással előállított eszköz alkalmazása rágcsálók irtására.

**14.** A 13. igénypont szerinti alkalmazás egérfélék (Muridae) családjába tartozó rágcsáló irtására, úgy mint házi egér (*Mus musculus*), gúzüegér (*Mus spicilegus*), mezei egér (*Mus agrarius* Pall), házi patkány (*Rattus rattus*), vándorpatkány (*Rattus norvegicus*) vagy egyéb rágcsálók.

**15.** A 14. igénypont szerinti alkalmazás, amelyben a rágcsáló házi patkány vagy vándorpatkány.

A meghatalmazott:

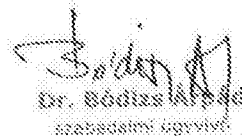

Dr. Bódis László  
szabadalmi ügyvivő  
SOGK Szabadalmi Ügyvivői Iroda  
H-1062 Budapest, Andrássy út 113.  
Telefon: +36-1-1000 Fax: 401-1099  
Email: bodus@soqk.hu