

Aug. 2, 1938.

B. W. FREEMAN

2,125,494

DIE

Filed Aug. 17, 1937

2 Sheets-Sheet 1

Fig. 1.

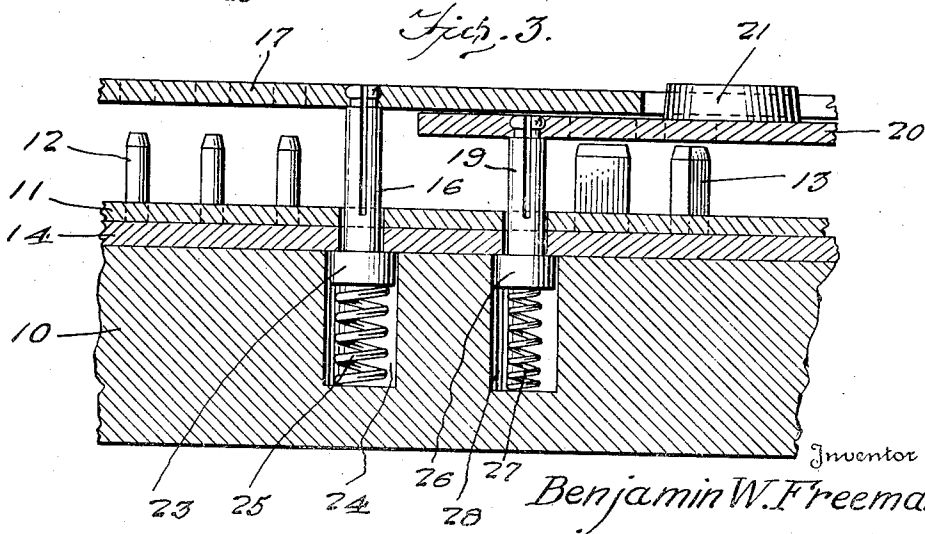
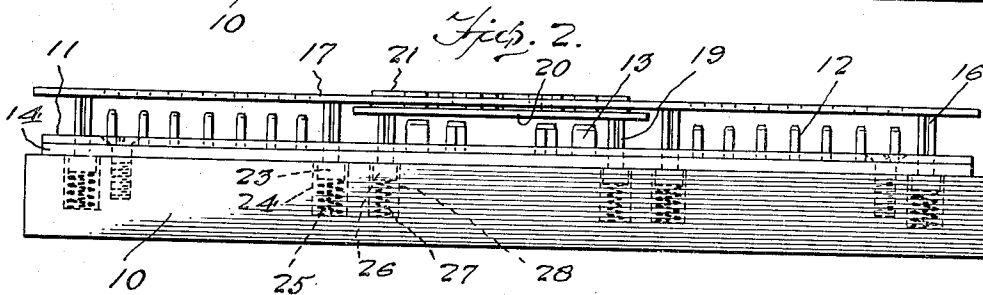
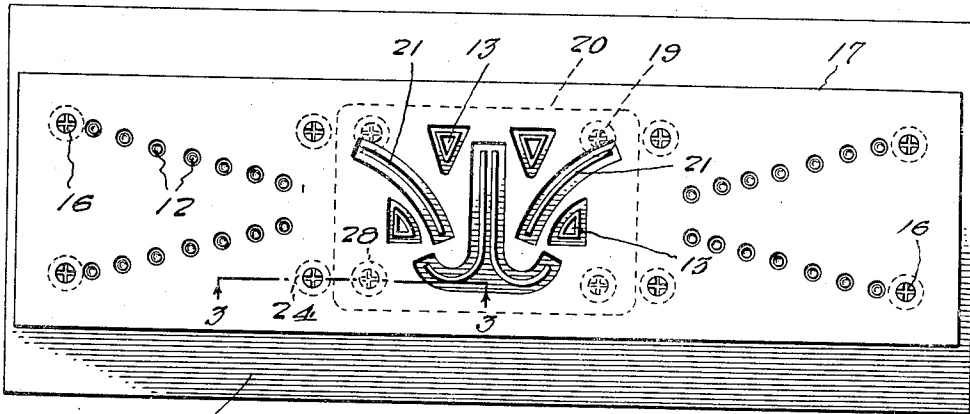

Inventor
Benjamin W. Freeman
By Rindow & Rindow
Attorney

UNITED STATES PATENT OFFICE

2,125,494

DIE

Benjamin W. Freeman, Cincinnati, Ohio

Application August 17, 1937, Serial No. 159,594

18 Claims. (Cl. 101—30)

This invention relates to shoe machinery and more particularly to improvements in dies for use in ornamenting shoe uppers and shoe parts by the formation of patterns of perforations or cut outs in portions thereof.

The illustrated embodiments of the invention disclose dies particularly adapted for operation upon shoe upper blanks, fitted or closed uppers or the like, in which the work is marked or printed with an ink or pigment, preferably in liquid form, during a single operation in which the work is ornamented by the perforating or cutting out of a design therein.

These dies, however, are by no means limited to combinations of marking and cutting, but may be used for either operation per se, and the marking may be effected solely by printing, or by indenting the work.

One embodiment illustrated herein, shows the invention applied to a style of die particularly designed for use in the type of machine disclosed in the Reissue Patent No. 20,294, granted March 16, 1937, to Benjamin W. Freeman et al, and in the copending application of Benjamin W. Freeman, Ser. No. 83,796, filed June 5, 1936.

The invention is also illustrated as applied to flat bed dies adapted for use in ornamenting machines or presses of the flat bed type. This type of die, while operable satisfactorily with various conventional flat bed machines, is also well adapted to use with the improved machine illustrated in a copending application of Benjamin W. Freeman, Ser. No. 11,277, filed November 25, 1936.

With many forms of work, the pressure requirements for perforating and for stripping are very heavy and the structures described in the aforesaid applications and patent are designed to meet such requirements, particularly with relation to the stripping of the work from the die.

Conventional strippers usually include some mechanism associated with the die unit, e. g. a stripper plate mounted on springs which normally serve to maintain the plate in a position flush with, or slightly advanced from the plane of the cutting edges of the die. The spring pressure must be so adjusted as to accommodate varying thicknesses of leather or material on which the die operates, and difficulties arise in this connection, especially when marking edges or ribs are placed on the stripper plate. Thus, if the spring pressure is adjusted to mark and properly strip a light piece of calf skin, it would probably injure a light piece of leather. Obviously when the material is thicker, the stripper will be de-

pressed more by such material, than would be the case with thin leathers.

Varying pressures are required with different characters of leather as well as with different thicknesses, and as the number of cut-outs and perforations in a piece of work is increased, the need for greater pressure likewise increases and such pressures are very difficult of attainment, if not impossible with conventional die mounted stripping devices now in use.

Hence, when a marking plate is used for the two-fold purpose of marking and stripping, difficulties are likely to arise in that too heavy an ink impression will be placed upon the work, or incomplete stripping will result, assuming that a conventional type of stripper pressure applying means is utilized. Again, there are many instances in which it is desired to place a marking upon the work in a spaced relation to perforations, or to the exclusion of perforations, and in such instances it is not necessary to strip at all in regions adjacent the marking.

Since an ink marking element should not indent, nor in any manner perforate the work, it is merely necessary to effect a light printing contact between the marking elements and the work. However, conventional stripping pressures required for removing a piece of work from the cutters are greater than the pressure required for properly printing or applying an ink mark to the surface of the work. It is desirable that the ink be kept on the surface and not forced into the fibers of the leather, nor below the normal surface, in order to provide a nice light legible mark which may easily be removed from the work, under circumstances where removal of such marks is found desirable. Too great a pressure is also harmful in that too much ink is applied, and the applied marks are apt to be unnecessarily wide and blurry, aside from the danger of injuring the work.

Even in the absence of pressure difficulties, when the marking elements are mounted on the stripper plate in a conventional manner, there is a tendency for the ink to smear, when the work is stripped from the die.

To the solution of these problems, the machine of Reissue Patent No. 20,294, and one form of the present invention, contemplate a stripping mechanism on the die, to which mechanism the pressure is applied by an arrangement independent of the die, this being accomplished by building a stripper pressure applying means into the machine as distinguished from supplying each independent die with a completely self-contained,

spring mounted stripping arrangement, of conventional nature.

The usual stripper plate, mounted in advance of the cutter, may be retained herein, wherever necessary, that is adjacent the cutting edges, but the marking elements are arranged independently of the stripper and operable in such a manner that the pressure required for stripping the work from the cutters is never applied to the marking portion of the die.

In those cases where the ink marking is applied without regard to perforating, the stripper plate may be eliminated and in the event that the pattern or design calls for perforations and markings side by side, the stripper plate may be only of such extent as is necessary to accommodate the cutter, and the marker may be left free.

Another embodiment of the invention, i. e., the application to a flat bed die contemplates a self-contained spring arrangement for applying stripper pressures to the stripper plate, but because of the independence of stripper and marker plates, the stripper springs may be located at points remote from the marker, and so arranged as to apply the stripping pressure without any effect on the marker itself. The marker, which will be resiliently mounted, may be supplied with light springs sufficient only for the purpose of providing a proper printing or marking pressure.

A primary object then of the present invention is the provision of a die with a structural design to facilitate the application of pressure to the stripper independently of the marker, or any marker pressure means, and with the stripper plate resiliently mounted for normal location flush or slightly advanced with respect to the plane of the cutting edges of the die, and so arranged that no real pressure will be exerted on the marker and hence on the work during a marking and/or cutting operation.

Such application of pressure to the stripper, independently of the marker may be provided by a completely self-contained arrangement, as by the use of springs in the base of the die, or through the medium of an external source of pressure independent of the die proper, or by a combination of both. The source of pressure for the marking plate will preferably be entirely self-contained as by the use of springs built into the die.

Another object includes the provision of a stripper plate having a smooth flat work-engaging surface such that when it presses against the work to strip same from the die, there will be no danger of cutting the work, irrespective of the stripping pressures applied. This surface permits exertion of a great deal of pressure against the work, it being understood that the marking elements are mounted separately, on light springs so that they just press against the work during the marking operation sufficiently to lay the ink lightly on the surface of the material, yet springs as heavy as desired may be utilized, at the same time, for the stripper plate.

In the event that it becomes desirable to utilize a die in accordance with the present invention, without recourse to a printing medium such as ink or pigment, the same structure could be made to apply an impression mark, or indentation into the work, merely by increasing the amount of pressure applied to the marking element as by increasing the weight of the springs under the marker.

In the illustrated arrangements, the marker is shown with the marking elements extending through openings in the stripper plate, and these

elements are made higher than the thickness of the stripper plate so that there can be no question at any time of these marking edges failing to adequately contact the work. The base of the marker is also shown as underlying the stripping plate except for the openings through which the marking ribs extend, i. e., the plate portion of the marker extends between the die base and the stripper and this makes it unnecessary to cut large openings in the stripper plate through which the entire marker might protrude.

The spring mounted marking plate may press up into engagement with the under side of the stripper when the die is not operating; when the die is functioning, the work engages the marker and moves same independently of the stripper until the work and stripper contact each other. Thereafter the marker and stripper move together, but during this movement the under side of the stripper is not contacting the marking plate, as when the die is in its non-operating position.

To the attainment of the foregoing and other objects which will appear as the description proceeds, reference may be made to the accompanying drawings, in which:

Fig. 1 is a plan of a flat bed die unit;

Fig. 2 is an elevation thereof;

Fig. 3 is an enlarged elevation thereof, partly in section, taken on line 3—3 of Fig. 1;

Fig. 4 is an elevation of a different form of die;

Fig. 5 is an enlarged elevation thereof, partly in section; and

Fig. 6 is an enlarged elevation partly in section of a modified type of mounting for the stripper and marker plates.

Referring now more specifically to the drawings, in which like reference numerals designate like parts, Figs. 1 to 3 illustrate the invention as applied to a flat bed die. This die has a base or die block 10, provided with any conventional means (not shown) for securing the die in place in an ornamenting machine, and with a tube or cutter plate 11, upon which is mounted a pattern of perforating tubes 12 and cutters 13 which may be individually of varied design. The tubes and cutters are, of course, relatively arranged into ornamental patterns. A sub-plate 14 is shown, although not essential, interposed between the tube plate 11 and the base or die block 10. It will be understood that the sub-plate 14 and block 10 will be suitably perforated in a conventional manner to provide exits or openings for the escape of chips and cuttings from the tubes 12 and cutters 13.

Split pins or studs 16 serve as snap fasteners to detachably support a stripper plate 17 in the die unit. This plate 17 is shown positioned in a plane advanced with respect to the cutting edges of the tubes 12 and cutters 13, but it might readily be located substantially flush with such edges, and still strip effectively. Studs 19 similar to the studs 16, function to mount detachably a marker plate 20, which plate has engraved, or otherwise secured upon it, projecting ribs 21, the exterior edges of which provide the work engaging, marking surfaces of the marker. Although shown as ribs for the sake of illustration, it will be understood that any suitable protuberances may be used, if occasion demands.

The studs 16 are each formed with an enlarged base or bearing portion 23 slidable in a socket 24 in the block 10, each socket being of greater diameter than the cooperative opening through the tube and sub-plates, provided for

the stem of the stud 16. Housed in each socket 24 beneath the enlargement 23 is a stripper spring 25, and by suitably distributing and proportioning these spring mountings, any desired degree of stripping pressure may be obtained.

The studs 19 for the marker plate are provided with enlarged bearing bases 26 which engage springs 27 in sockets 28. It will be noted, however, that the springs 27 are much lighter than the stripper springs 25, and are proportioned to apply merely the proper degree of pressure to the marker 20, necessary to printing. These springs also serve to position the ribs 21 in advance of the stripper plate and cutting edges, to permit the application of ink thereto without getting any ink on the adjacent parts of the die.

With this arrangement, and with the stripper 17 arranged to overlie the marker plate 20, it will be quite evident that the resistance of the marker to the work is solely governed by the springs 27, and that the stripper 17 is free to exert any amount of pressure required for stripping, and neither plate is influenced by the other, except for limitations of outward movement of the marker plate which may be imposed by the stripper plate. Thus in operation, and with a work piece in proper position, the marker will first be depressed, the stripper will follow, and when the operation is complete, the stripper will force the work off of the cutting members and tubes, and the marker will idle along thereafter, it being immaterial whether the marker 20 actually engages the stripper on its under side, or not.

Referring now to Figs. 4 and 5, there is illustrated a die of the type particularly adapted for use in the machine described in Reissue Patent No. 20,294. This die, in a preferred form, comprises a base plate 30, by means of which the unit is secured in an operating position in a machine. A dove-tailed wedge 31, and a perforated lug or ear 32 may be mounted on the base plate to cooperate with suitable locking means in the machine, as described in said reissue patent.

Secured to the base plate 30 by means of struts or sleeves 33 is a die block 34, upon which is mounted a cutter or tube plate 35, the latter being suitably perforated at the base of the tubes in a familiar manner to permit expulsion of chips or cuttings. A single block, suitably apertured for exit of cuttings or chips might be used in lieu of the base plate 30 and the die block 34. However, spacing between the base plate 30 and the block 34 provides a chamber for the reception of chips or cuttings from the work, regardless of whether the space is enclosed or not. Further, the preferred structure as described is more economical in manufacture, lighter in weight, and facilitates adjustment or variation in the height of the die plate. Hence, it will be seen that the preferred form is more desirable than the single block idea, which latter is mentioned as an illustration of what falls within the scope of the instant invention.

In the illustrated embodiment the tubes 36 are arranged in spaced groups, and intermediate these groups is a marker comprising a plate 37 having marked edges or ribs 38 thereon. The plate 37 is resiliently mounted in the die by split pins or snap studs 39 having enlarged bases or bearing portions 40 which slide in certain of the sleeves 33, springs 41 being encased by the sleeves 33 normally to maintain the plate 37 in a projected position. As in the case of the flat bed die, these springs are very light, no real pres-

sure being required against the plate 37. In fact, where the die operates downwardly as illustrated, the springs may be omitted entirely and the weight of the marking die will be sufficient to maintain it projected beyond the plane of the cutting edges, where it may be inked without inking the cutting tubes or stripper. However, in order to insure that the edges 38 are maintained in advanced position, during inking and in view of the fact that with some installations the die may be reversed to operate upwardly, it is preferred to use springs.

A stripper plate 42 is provided for the perforating members 36, this plate being carried by split pins 43 with bearing portions 44 which operate in additional struts or sleeves 33, as in the case of the pins 39. However, the pins for the stripper have extension 45 of a length to permit projection thereof through the base plate 30, which is suitably perforated for the purpose. Relatively heavy springs 46 encircle the extensions 45, within the sleeves.

The purpose of the extensions 45 is to receive pressures developed in the machine for which the die is designed, in a manner described in Reissue 20,294, and it will be evident that while any desired degree of pressure may be transmitted to the stripper 42 through these extensions 45 that just as in the case of the flat bed die, above described, there is a complete independence between the marker and the stripper, and the relative operation of these elements is exactly as described above. It will be further understood in connection with both forms of die that the arrangement or pattern of cutting elements, and the relation thereof to the marking ribs is variable, to accord with different runs of shoes.

Fig. 6 illustrates a modified mounting for the stripper and marker. In this mounting the springs 47 and 48 encircle the split pins for the stripper and marker respectively, at a location between the tubes or cutter plate 49 and the under side of the stripper 50 and marker 51. The sockets 52 and 53 are accessible from the exterior of the die block 54. This type of mounting while illustrated in connection with a flat bed die is obviously applicable to other types of die.

From the foregoing description the operation and advantages of the invention will be readily apparent. When the die unit is secured in operating position, in its proper type of machine, and pressure applied to produce a relative movement between the die and the work to be treated, the work and marking ribs will first engage each other with a resultant depression of the marker, followed by a depression of the stripper, with, however, no interference between the two. When pressure is relieved, and the work and die separate, the stripper and marker will begin to move outwardly as a unit, but with the stripper exerting pressure from whatever source obtained, to remove the work from the cutter.

Many advantages, additional to prevention of ink smearing and work injury, accrue in the manufacture of dies as herein described. Marking plates, stripping plates, and the like, may be made in sections corresponding to the work to be cut and marked, and may be provided with operating surfaces having portions higher at various points than at others, thereby accommodating the die to laminated work, such as appliques, overlays, foxings, saddles, and the like,

which in an assembled shoe upper, form a surface varying in level.

A marking plate made in sections will adjust itself readily to care for varying levels or thicknesses of the work without exerting greater pressures on high points than on low points of the work surface, and thus the marking will be uniform throughout. Again, an even distribution of pressure is attained, regardless of the particular die used, and tendency toward rocking or tilting of the stripper is avoided. This prevents binding of the stripper plate with attendant failure to strip. Any desired degree of pressure for stripping may be applied.

If it is desired to use the die for marking purposes which do not require a separately applied medium, such as ink or pigment, merely increasing the strength of the marking springs 27, 41 or 48 to provide a greater pressure against the respective marking plates may be effected, and the work may then be marked by indenting or impressing the marking ribs into the work, regardless of the pressures applied for stripping purposes.

It is, of course, not essential that a single die unit including both marking and cutting elements be provided, since the several marking and cutting sections might readily be made independent of each other, as in Fig. 4, or combined by arranging certain cutting members to project through the marking plate, as in Fig. 1.

It is understood that the embodiment of the invention shown and described herein is intended as illustrative, rather than limiting, as many modifications within the scope of the invention will occur to those skilled in the art. For example, the arrangement of any of the dies herein illustrated may be such as to cut up or down, the relative movement between the die and the work may be obtained by moving the die toward a fixed work support, or by moving the work to a relatively fixed die; the die itself may be made with a single base plate or block, or with a die block spaced by struts from a base plate, as described herein. Hence, such terms as underside, overlying, top or bottom as used herein are to be regarded as descriptive, and not limiting.

Having thus described my invention, what I claim as new and desire to secure by Letters Patent of the United States, is:

1. In a die of the class described, a base, cutting means mounted thereon, marking means independent of said cutting means also mounted on said base, and stripping means for said cutting means constructed and arranged for operation free and independently of said marking means, said marking means having a portion extending between said stripping means and said base, in normal juxtaposed relation to said stripping means.

2. In a die of the class described, a base, cutting means mounted thereon, marking means independent of said cutting means also mounted on said base, and stripping means for said cutting means constructed and arranged for operation free and independently of said marking means, said marking means having a portion extending between said stripping means and said base, resilient means mounting said marking means and effective to impart a light printing pressure thereto during operations on work, and to hold said marking means normally in juxtaposed relation to said stripping means, and resilient means mounting said stripping means effective to im-

part a relatively heavier pressure thereto for stripping purposes.

3. In a die of the class described, a base, a plurality of cutting units on said base, a marking unit adjacent said units and stripping means for said cutting units arranged in spaced relation to said marking unit for operation independently thereof, said marking means having a portion extending between said stripping means and said base, in normal juxtaposed relation to said stripping means.

4. In a die of the class described, a base, a plurality of cutting units on said base, a marking unit adjacent said units and stripping means for said cutting units arranged in spaced relation to said marking unit for operation independently thereof, said marking means having a portion extending between said stripping means and said base, resilient means mounting said marking means and effective to impart a light printing pressure thereto during operations on work, and to hold said marking means normally in juxtaposed relation to said stripping means, and resilient means mounting said stripping means effective to impart a relatively heavier pressure thereto for stripping purposes.

5. In a die of the class described, a base, a plurality of cutting units on said base, a marking unit adjacent said units, and common stripping means for all of said cutting units constructed and arranged to provide for free operation of said marking unit therethrough, said stripping means having a portion extending over and across said marking unit, in normal juxtaposed relation to said stripping means, on the opposite side thereof from said cutting units.

6. In a die of the class described, a base, a plurality of cutting units on said base, a marking unit adjacent said units, and common stripping means for all of said cutting units constructed and arranged to provide for free operation of said marking unit therethrough, said stripping means having a portion extending over and across said marking unit, on the opposite side thereof from said cutting units, resilient means mounting said marking means and effective to impart a light printing pressure thereto, during operations on work, and to hold said marking means normally in juxtaposed relation to said stripping means, and resilient means mounting said stripping means effective to impart a relatively heavier pressure thereto for stripping purposes.

7. In a die of the class described, a base, a marking plate mounted resiliently thereon, cutting means on said base having a stripper plate superposed over said marking plate and yieldably mounted on said base, said marking plate and stripper plate being constructed and arranged for free movement independently of each other.

8. In a die of the class described, a base, a marking plate mounted resiliently thereon, cutting means on said base having a stripper plate superposed over said marking plate and yieldably mounted on said base, said marking plate and stripper plate being constructed and arranged for free movement independently of each other, the resilient mounting for said marking plate being of a strength sufficient only to impart a light printing pressure thereto, and the yieldable mounting for said stripper plate being effective to impart a relatively heavier pressure thereto for stripping purposes.

9. In a die of the class described, a base, a marking plate mounted resiliently thereon, and

provided with marker portions, cutting means on said base having a stripper plate superposed over said marking plate and yieldably mounted on said base, said marking plate and stripper plate being constructed and arranged for free movement independently of each other, said stripper plate being constructed to at least partially surround the marking portions of said marking plate whereby said marking portions may operate freely therethrough.

10. In a die of the class described, a base, a marking plate mounted resiliently thereon, and provided with marker portions, cutting means on said base having a stripper plate superposed over said marking plate and yieldably mounted on said base, said marking plate and stripper plate being constructed and arranged for free movement independently of each other, said stripper plate being constructed to at least partially surround the marking portions of said marking plate whereby said marking portions may operate freely therethrough, the resilient mounting for said marking plate being of a strength sufficient only to impart a light printing pressure thereto, and the yieldable mounting for said stripper plate being effective to impart a relatively heavier pressure thereto for stripping purposes.

11. A die of the class described comprising a base, cutting means on said base, marking means adjacent to and movable with relation to said cutting means, said marking means including marking elements adapted to receive ink, means resiliently mounting said marking elements on said base in a plane advanced with respect to that of the cutting means, said resilient mounting being proportioned and arranged to develop a pressure sufficient only to provide a light contact of the marking elements with the work piece during cutting movement, thereby to ink mark the work piece as part of a single marking and cutting operation, a stripper for said cutting means positioned to overlie said marking means, and means resiliently mounting said stripper, said stripper mounting being proportioned and arranged to develop a pressure of greater intensity than that of said marking means.

12. A die of the class described comprising a base, cutting means on said base, a plate adjacent to and movable with relation to said cutting means, said plate being provided with marking elements adapted to ink mark the work during a cutting operation, mounting means for said plate having an amplitude of movement greater than that portion of the cutting means of the die which must penetrate the work in order to cut it, spring means resisting movement of said mounting means insufficiently to build up a pressure, during the penetration of work by said cutting means, greater than required for ink marking the work without penetrating or indenting the same, stripping means for said cutting means resiliently mounted for operable movement independently of said marking means, and positioned to overlie said marking means.

13. A die of the class described comprising a base, cutting means on said base, a plate adjacent to and movable with relation to said cutting means, said plate being provided with marking elements adapted to ink mark the work during a cutting operation, mounting means for said plate having an amplitude of movement greater than that portion of the cutting means of the die which must penetrate the work in order to cut it, spring means resisting movement of said mounting means insufficiently to build up a pres-

sure, during the penetration of work by said cutting means, greater than required for ink marking the work without penetrating or indenting the same, stripping means for said cutting means resiliently mounted for operable movement independently of said marking means, and positioned to overlie said marking means, said resilient means for said stripping means being proportioned to develop pressures greater than the spring means for said marking means.

14. A cutting and marking instrumentality for use in a cutting and marking operation wherein means is provided for developing stripping pressures exclusive of the cutter and marker, comprising a base, cutting means on said base, marking means overlying and movable with relation to said cutting means, said marking means being formed with marking elements effective to ink mark the work during a cutting operation, mounting means for said marking means having an amplitude of movement greater than that portion of the cutting means of the instrumentality which must penetrate the work in order to cut it, and spring means resisting movement of said mounting means insufficiently to build up a pressure, during penetration of work by said cutting means, greater than required for ink marking the work without penetrating or indenting the same by said marking elements, stripping means positioned to overlie said marking means on the opposite side thereof from the cutting means, and operable independently of said marking means to remove the work from the cutting means.

15. A flat bed die of the class described comprising a base, cutting means mounted thereon, marking means mounted on said base and stripping means for said cutting means also mounted on said base, means yieldably mounting said stripping means effective normally to position said stripping means in a plane beyond the plane of the cutting edges of said cutting means, and to develop during operation of the device, pressures sufficient to strip a work piece from said cutting means, means resiliently mounting said marking means effective normally to position said marking means in a plane beyond the plane of said stripping means, and to develop during operation of the device, pressures sufficient only for marking purposes, said marking means having a portion underlying said stripping means.

16. A flat bed die of the type described comprising a base, cutting means on said base, marking means on said base positioned in a plane above said cutting means, stripping means for said cutting means mounted on said base and positioned in a plane above said marking means, said cutting means being constructed and arranged to permit operation of said marking means therethrough, means resiliently mounting said marking means independently of said stripping means and effective to apply to said marking means a pressure sufficient only for marking the work, and means resiliently mounting said stripping means effective to develop relatively greater pressures of a degree sufficient to strip the work from the cutting means, said marking means and stripping means being operable independently of each other.

17. In a die of the class described, a base, cutting means mounted thereon, marking means independent of said cutting means also mounted on said base, and stripping means for said cutting means constructed and arranged for operation free and independently of said marking

means, said marking means having a portion extending between said stripping means and said base, in normal juxtaposed relation to said stripping means, and means mounting said marking means in a position where ink may be applied thereto to the exclusion of said cutting means and said stripping means.

18. In a die of the class described, a base, cutting means mounted thereon, marking means independent of said cutting means also mounted on said base, and stripping means for said cutting means constructed and arranged for operation free and independently of said marking means, said marking means having a portion extending

between said stripping means and said base, in normal juxtaposed relation to said stripping means, resilient means mounting said marking means and effective to apply sufficient pressure to said marking means, during an operation on the work, to impress or indent a mark in the work, and to hold said marking means otherwise in juxtaposed relation to said stripping means, and yieldable means mounting said stripping means effective to impart a relatively different pressure to said stripping means sufficient to remove the work from the cutting means.

BENJAMIN W. FREEMAN.