

(19)



(11)

EP 2 063 041 A1

(12)

EUROPEAN PATENT APPLICATION

(43) Date of publication:
27.05.2009 Bulletin 2009/22

(51) Int Cl.:
E04C 2/28^(2006.01) E04C 2/38^(2006.01)

(21) Application number: **08157652.2**

(22) Date of filing: **05.06.2008**

(84) Designated Contracting States:
AT BE BG CH CY CZ DE DK EE ES FI FR GB GR HR HU IE IS IT LI LT LU LV MC MT NL NO PL PT RO SE SI SK TR
Designated Extension States:
AL BA MK RS

(71) Applicant: **Finja AB**
Hässleholm (SE)

(72) Inventor: **Svensson, Peter**
288 32 Vinslöv (SE)

(74) Representative: **Karlsson, Leif Gunnar Börje**
Ström & Gulliksson AB
P.O. Box 4188
203 13 Malmö (SE)

(30) Priority: **23.11.2007 SE 0702589**

(54) **A Wall Element**

(57) A prefabricated wall element comprises a first insulation layer (200) and a second insulation layer (300) arranged on the first insulation layer (200). The second insulation layer forms channels for allowing the molding of a load bearing concrete structure. A third insulation layer (400) is arranged such that it covers the second insulation layer (300) and the load bearing concrete structure and a concrete layer (500) covers the third insulation layer (400). A skeleton (100) including beams (110, 120, 130) having a first side adapted for fastening of boards and a second side faces the first insulation layer (200).

Fig. 5

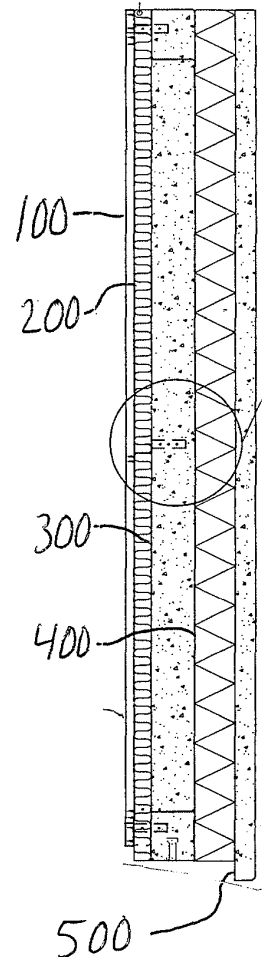

EP 2 063 041 A1

Description

FIELD OF THE INVENTION

[0001] The present invention relates to a prefabricated wall element comprising: a first insulation layer, a second insulation layer arranged on the first insulation layer and forming channels for allowing the molding of a load bearing concrete structure. A third insulation layer is arranged such that it covers the second insulation layer and the load bearing concrete structure and a concrete layer covers the third insulation layer.

[0002] The invention also relates to a method of manufacturing a wall element.

PRIOR ART

[0003] For house building, it is well known to use prefabricated wall elements made of reinforced concrete. In general, such wall elements include an outer, load bearing shell and an inner shell, both made of reinforced concrete. An insulating layer is usually provided between the inner shell and the outer shell. Wall elements of the known type have many advantages; they are easy and fast to mount, give an even indoor temperature due to the thermal inertia of the heavy inner shell and a good sound insulation. Moreover, prefabricated concrete wall elements provide excellent resistance to fire and decomposition caused by water entrainment.

[0004] There are, however, some drawbacks connected to the prior art wall elements; firstly, they are heavy. The weight is detrimental from many points of view, mainly handling, but also regarding manufacturing cost. Another severe drawback is that the internal surface of the wall (i.e. the inner shell) is "ready for use". All wiring inside the wall, e.g. electrical wires, radiator heating pipes, telephone wiring, computer wiring, etc., must be installed or prepared for during manufacturing of the wall element. Retrofitting of wiring and piping inside the wall is very complicated.

[0005] Also, when it comes to manufacturing of concrete wall elements, there are some major problems to be solved. The manufacturing method for prior art element comprises basically the following steps:

[0006] In a first manufacturing step, a form is arranged on a flat, glossy mould table. The internal volume contained by the form is reinforced, e.g. by reinforcement bars.

[0007] In a second manufacturing step, concrete to form an inner outer wall of the wall element is poured into the form. Often, reinforcement bars are arranged to extend up from the surface formed by the poured concrete.

[0008] Thereafter, a layer of insulation is laid on top of the poured concrete. The reinforcement bars extending up from the poured concrete will extend through the insulation and be joined with another reinforcement that is added on top of the insulation.

[0009] In a final manufacturing step, concrete is poured

onto the insulation. The concrete is allowed to harden overnight, and the following morning (or later) the wall element is removed from the mould table to leave room for manufacturing of another wall element.

[0010] The main problem with the manufacturing process for prior art wall elements is the forming procedure, which is very time consuming, and also the cleaning, or rinsing, of the form. Moreover, it is often necessary to apply a release agent (or mould agent) to the form prior to concrete pouring. The release agent might add an unwanted color change to the concrete, and is also expensive.

[0011] For manufacturing of prior art wall elements, it is necessary to occupy the mould table for two consecutive days for manufacturing a single wall element; the first day, the wall element manufactured the day before is removed, the mould table is cleaned, the form is built, and the first reinforcement layer is provided. The concrete is poured the following morning, and the concrete is left to harden over night; hence, the mould table will be occupied for two entire work days.

[0012] One wall type having some of the aforementioned benefits is a wooden wall; such a wall generally comprises a structure made from wooden beams, and the inside is covered with plaster board; it is light and it is relatively easy to retrofit the wall with internal wiring and piping. There are, however, some severe drawbacks with wooden walls, primarily that they are not very resistant to fire, and that they may rot if subjected to water or moist.

[0013] The object of the present invention is to provide a wall element that is lighter than the prior art prefabricated wall elements, have the same (or better) resistance against fire, that allow easy retrofitting of internal wiring, and that does not rot.

[0014] It is also an object of the present invention to provide a method for manufacturing a wall element having the benefits according to the above, which method allows manufacturing of a wall element in a single day.

SUMMARY OF THE INVENTION

[0015] The invention solves, or at least mitigates, some or all of the above problems by providing a prefabricated wall element comprising a skeleton including beams having a first side adapted for fastening of boards and a second side facing the first insulation layer.

[0016] In order to attain a good resistance to fire, a first insulation layer may be made from mineral wool. In order to get a soundproof and moisture blocking wall, the second and third insulation layers may be made from expanded or extruded polystyrene.

[0017] In order to avoid use of organic material in the wall, the beams of the skeleton may be made from profiles of sheet metal.

[0018] In order to increase the strength of the skeleton, it may be fastened to the load bearing concrete structure by elongate fastening means.

[0019] In order to avoid that the fastening means extends through the first insulation during the arrangement of the channels in the second insulation layer, the elongate fastening means may be a screw extending through the first insulation layer, from the skeleton to the load bearing concrete structure. By using a screw, it is possible to arrange the screw after the second insulation layer has been arranged.

[0020] In order to facilitate fitting of wiring in the wall, the skeleton may be arranged such that it faces an indoor space of a building.

[0021] In order to get an even indoor temperature, the wall may be arranged such that the concrete layer faces an indoor space of a building.

[0022] The invention also relates to a method of manufacturing a wall element. The method includes the steps of:

- a. arranging a skeleton comprising beams in a mould;
- b. covering said beams with a first insulation layer;
- c. onto said first insulation layer, applying a second insulation layer defining channels adapted for molding a load bearing structure;
- d. arranging fastening means extending from the channels, through the first insulation layer, to the beams;
- e. pouring concrete into the channels;
- f. covering said concrete and said second insulation layer with a third insulation layer and
- g. covering the third insulation layer with a layer of concrete.

[0023] In order to increase the strength of the wall, reinforcement bars may be arranged in the channels, and on the third insulation layer prior to pouring the concrete in the channels and on the third insulation layer, respectively.

BRIEF DESCRIPTION OF THE DRAWINGS

[0024] In the following, the invention will be described with reference to the drawings, wherein:

- Fig. 1 is a plan view showing a skeleton usable in a wall element according to the present invention;
 Fig. 1b is a section view of a sheet metal profile usable for the skeleton of Fig. 1;
 Fig. 1c is an end view of a crossbeam;
 Fig. 1d is an end view of a reinforcement part usable to increase the strength of the skeleton of Fig. 1;
 Fig. 2 is a perspective view of the skeleton of Fig. 1;
 Fig. 3 is a perspective view showing partly the skeleton of Fig. 1 in a larger scale, and partly some layer of insulation;
 Fig. 4 is an exploded perspective view showing a wall element according to the present invention;
 Fig. 5 is a section view of a wall element according

to one embodiment of the present invention;

Fig. 6 is a plan view showing a load bearing concrete structure of one embodiment of the wall element according to the present invention;

Fig. 7 is a perspective view showing a frame combined with a skeleton usable in connection with molding a wall element according to the present invention;

Fig. 8 is a perspective view showing the combined frame and skeleton of Fig. 7; and

Fig. 9 is a section view of one embodiment of a wall element according to the present invention.

DESCRIPTION OF EMBODIMENTS

[0025] Below, some embodiments of wall elements according to the present invention will be described.

[0026] In Fig. 1, a fastening skeleton 100 is shown. The skeleton 100 may be manufactured from any suitable material enabling fastening by screws, e.g. a sheet metal profile, although it may also be possible to use plastic or wood for the skeleton 100.

[0027] The skeleton 100 comprises standing beams 110 placed in parallel relationship to one another. The distance between the beams 110 may e.g. be 450mm or 600 mm. At both ends of the beams 110, the beams are fastened to upper and lower beams 120 and 130, respectively. The upper 120 and lower 130 beams extend perpendicularly to the beams 110.

[0028] In Fig. 1b, a typical profile usable for the beams 110, 120, 130 is shown. The profile can, as mentioned, be manufactured from sheet metal, and comprises a front portion 111, side portions 112 and a back portion 113. In the shown embodiment, the back portion 113 is provided with an opening; this opening has, however, no effect, but is the result of manufacturing the profile from sheet metal.

[0029] Moreover, the skeleton 100 may comprise a crossbeam 140. In one embodiment of the invention, the crossbeam 140 is a Z-profile made from sheet metal. In Fig. 1c, the z-profile is shown; the Z-profile comprises three different portions, namely an upper portion 141, an intermediate portion 142 and a lower portion 143. The lower portion 143 is fastened to the back portion 113 of the beams 110. Moreover, the intermediate portion has a height (i.e. the distance between the upper and lower portions 141 and 143, respectively) that corresponds to a thickness of an insulation layer that is placed onto the skeleton 100. Furthermore, the crossbeam 140 might be provided with means 145 for fastening the crossbeam to further sections of the wall element; examples of such means can be found in Fig. 2 and comprise a perforated steel ribbon fastened in the crossbeam 140.

[0030] Finally, the upper and lower beams 120 and 130 are fastened to the beams 110 in a suitable manner. One such manner could be the use of nail plates 115, which e.g. is screwed flush with the back portion 113.

[0031] In one embodiment of the invention, the nail plates 115 are screwed the back portion 113 of the beams

113, the upper beam 120 and the lower beam 130. In order to increase the strength of the screws, a reinforcement part 150 may be inserted into the profile comprised in the beams 110, 123 and 130. The reinforcement part 150 could comprise two screw portions 151, two support legs 152 and an intermediate surface 153 situated between the two screw portions 151. In the shown embodiment of the reinforcement part 150, the intermediate surface 153 has a lower level as compared to the screw portions 151. This has an effect that will be described later. The reinforcement part 150 is as mentioned inserted into the profile it is supposed to reinforce; it is inserted such that the screw portions 151 will abut the back portion 113 of the beams 110, 120 and 130. In this position, the support legs 152 will extend from the corners defined by the front portion 111 and the side portions 112 to the screw portions 151, and hence serve to hold the screw portions 151 firmly against the back portion 113.

[0032] A three-dimensional view of a skeleton 100 (provided with a crossbeam) is shown in Fig. 2. Moreover, in the embodiment shown in Fig. 2, the reinforcement parts 150 are shown, being placed in the ends of each beam 110.

[0033] As mentioned in the "Summary of the invention", the invention relates to a wall element, and in order to obtain the wall element, the following measures are taken, reference being made to Figs. 3, 4 and 5:

[0034] In a first step, the skeleton 100 is placed on a horizontal surface, and a form, or mould, is arranged such that it snugly surrounds the skeleton 100.

[0035] In a second step, a first layer of insulation 200 is laid flat onto the skeleton 100; this insulation layer should be rigid enough to support the weight of following layers of insulation and reinforced concrete. In one embodiment of the invention, the insulation layer 200 is an insulation made from mineral wool, although other types of insulation can be used (for example, boards of expanded or extruded polystyrene).

[0036] In a third step, a second insulation layer 300 is laid on top of the first insulation layer 200. The second insulation layer 300 is placed such that channels are formed in the insulation layer 300. In one embodiment of the invention, channels are formed between the insulation layer 300 and the form (or mould) that surrounds the skeleton 100, and also in the insulation layer 300 itself. Preferably, the channels extend in the same direction as the beams 110.

[0037] In a fourth step, reinforcement bars of a type suitable for reinforcement of concrete are laid in the channels. This type of reinforcement is well known by persons skilled in the art, and will hence not be described further.

[0038] In a fifth step, elongate fastening means 310, e.g. screws, are fastened in the nail plates 115. The length of the elongate fastening means 310 should be such that they extend through the first insulation layer and well into the channels formed by the second insulation layer. Here, it may be mentioned that the provision of the intermediate surface 152 of the reinforcement part

150 on a lower level than the screw portions 151 actually serves a purpose; if an elongate screw is used as the fastening means 310, this screw may be screwed through both the nail plate 115 and the intermediate surface 153 of the reinforcement part 150. Due to the distance between the intermediate surface 153 and the nail plate 115, the screw will be able to withstand larger bending forces than would be the case if the distance between the nail plate 115 and the intermediate surface was smaller.

[0039] In a sixth step, concrete is poured in the channels formed by the second insulation layer 300. Preferably, the concrete is poured to a level that makes the upper surface of the concrete flush with the top of the insulation layer 300.

[0040] In a seventh step, a third layer 400 of insulation is applied onto the second insulation layer and the poured concrete.

[0041] In a final step, a concrete layer 500 is poured onto the third layer of insulation.

[0042] It should be noted that it is preferred if the concrete layer 500 is connected to the concrete poured into the channels formed in the insulation layer 300. This connection can be achieved e.g. by means of plates (not shown) provided with openings for insertion of reinforcement bars. This technique for connecting concrete layers divided by an insulation layer is well known by persons skilled in the art, and will hence not be described further.

[0043] After the concrete in the channels and the concrete layer has hardened, the wall element can be removed from the horizontal surface and be transported to a building site. It should be noted that the horizontal surface on which the wall element is manufactured will be clean after the wall element has been removed; hence, a large amount of work can be saved.

[0044] On the construction site, the wall element according to any of the above embodiments can be used in at least two ways;

[0045] In a first use embodiment, the wall element is used such that the skeleton 100 will face in a direction corresponding to an interior volume of the building. In such a case, the skeleton is preferably covered with e.g. a plaster board (600) to form an interior wall surface pleasing to the eye. As mentioned earlier, the skeleton 100 is preferably made from a material allowing screwing, and if the material used for the skeleton allows for screwing, the plaster boards can be fastened by screws. It is, however, also possible to use e.g. glue to fasten the plasterboards to the skeleton 100. The first use embodiment has the advantage that it is possible to fit the wall with e.g. electric wiring prior to the provision of the plaster boards on the skeleton.

[0046] In a second use embodiment, the wall element is used such that the skeleton 100 will face "outwards", i.e. towards the surface intended to become the outer wall. In such a case, the skeleton is preferably clad with a board resistant to the influence of weather and wind. The second use embodiment has two advantages over

prior art walls; firstly, it is possible to renew a worn façade, and moreover, the indoor temperature will be more even.

[0047] In another embodiment of the invention, a frame surrounds the skeleton. This embodiment will be described below, with reference to Figs. 6 to 10. Most features are common for the earlier described embodiments and the embodiment that will be described below, and the methods for manufacturing the wall element are identical, but for the sake of clarity, the description will be complete also for the following embodiments. Moreover, details not described in the above embodiments may be used for those embodiments, and details described for the above embodiments, but not for the following embodiments may be used for them.

[0048] In Fig. 6, a plan view of a concrete grid 10 comprised in one embodiment of a prefabricated wall element according to the present invention is shown. The concrete grid 10 comprises a ground beam 11, a main bar 12 and columns 13 connecting the ground beam 11 and the main bar 12. If the grid 10 is to be used in a wall element for a room in a lower plane, the columns might extend slightly above the upper level of the main bar 12, in order to enable fastening of a double flooring for an upper plane in the lateral plane.

[0049] In most cases, the ground beam 11, the main bar 12 and the columns 13 are reinforced, preferably by steel reinforcement bars in a way well known by persons skilled in the art, by steel fibers, or by glass fiber reinforcements, either in form of short fibers, or in form of elongate bars.

[0050] The distance between the columns may be chosen depending on such factors as the weight of upper storey's supported by the wall element, strength of the columns (which, in turn, depends on the amount of reinforcement used in the column, and its width) and strength of the main bar; should a beam of the double flooring for an optional upper plane rest on the main bar between two columns and the distance between two adjacent columns be large, it is crucial that the main bar is sufficiently strong.

[0051] In Fig. 2, a frame/form 20a used for manufacturing and constituting an outer limit of the finished wall element of the present invention is shown. The frame/form 20a comprises two horizontal frame members 21, 22 and a number of vertical frame portions 19. Such vertical frame portions could e.g. be used for delimiting vertical walls of a window opening, such as shown in the blow-up B1 of Fig. 6. As can be seen in B1, further frame portions 19a and 19b, which delimit horizontal walls of the window opening, join the vertical frame portions 19 delimiting the vertical walls of the window opening.

[0052] In a preferred embodiment of the invention, the frame/form 20a might be manufactured from U-shaped sheet metal profiles, wherein the opening of the U preferably faces inwards with regards to the frame portions 19, 21 and 22, i.e. opening of the U will face the concrete used to manufacture the wall.

[0053] In Fig. 8, the same frame/form 20a is shown,

but in Fig.8, the frame/form 20a is provided with vertically extending sheet metal profiles 17, which join the two horizontal frame members 21, 22 and serve as suspension beams for gypsum or plaster boards used as inner walls of the wall element of the present invention. The sheet metal profiles may e.g. be of the type sold by Lindab under the trade name S7-25, which are adapted for allowing screwing of the gypsum or plasterboards to the sheet metal profiles. It is also possible to glue the plasterboards to the sheet metal profiles, but which method that is used is up to the persons mounting the wall element in the building to be built by these wall elements.

[0054] The sheet metal profiles 17 may be fastened to the horizontal frame members 21, 22 and the frame portions 19a and 19b in any suitable way, e.g. by screwing, gluing, riveting, welding or by spot welding.

[0055] Fig. 9 shows a finished wall element according to the present invention. Starting from the bottom of the figure, i.e. the inner side of the wall, there is a plasterboard attached to the sheet metal profiles 17. Following the sheet metal profiles 17, there is an insulation layer 20, e.g. an expanded plastic board or a board of mineral wool. An insulation layer 15, which also could be manufactured from either mineral wool or from expanded plastic, follows the insulation layer 20. The insulation layer 15 and the insulation layer delimits at least two sides of the vertical concrete columns 13.

[0056] On the outside of the insulation layer 15 and the columns 13, an insulation layer 30 is provided, and on the outside of the insulation 30, there is provided a concrete layer 31. The insulation layer 30 is perforated by plates (not shown) of stainless steel extending from the columns 13 to the concrete layer 30. The purpose of the stainless steel plates is to fix the mutual position of the columns and the concrete layer 30. On one embodiment, the steel plates are perforated, and reinforcement bars are placed in the perforations and allowed to fasten in the poured concrete.

[0057] Below, the manufacturing process for a wall element according to the present invention will be described.

[0058] In a first manufacturing step, the frame/form 20a is assembled, e.g. by welding, gluing, riveting, welding or point welding. In order to prevent the frame portions 21, 19, 19a, 19b from rusting, it might be suitable if these portions are painted or covered by a thin zinc plating.

[0059] In a second manufacturing step, the sheet metal profiles 17 are fastened to the frame portions 21.

[0060] In a third manufacturing step, the sheet metal profiles 17 are laid down flat on a horizontal surface such that the frame portions 21 will face "upwards". In some cases, it might be useful if it is possible to "tilt" the horizontal surface in order to facilitate removing of a finished wall element. In conjunction to this step, it might be suitable to build a form for allowing pouring of concrete on a higher level than allowed by the frame/form 20a.

[0061] In a fourth manufacturing step, the insulation layer 20 is laid onto the sheet metal profiles 17. In this

context, it might be added that the insulation layer 20 preferably should be rigid enough to support the weight of concrete to be poured onto the insulation layer 20.

[0062] In a fifth manufacturing step, the insulation 15 is attached to the insulation, such that there will be "channels" delimited by side walls of the insulation 15 or the frame 21 and by top surfaces of the insulation 20. These channels will be filled with concrete in a subsequent manufacturing step and hence form the main bar 12, the columns 13 and the ground beam 11.

[0063] In a sixth manufacturing step, reinforcement bars in the required thicknesses and numbers are laid in the channels forming the main bar 12, the columns 13 and the ground beam 11. The reinforcement bars are laid in such channels in a way well known by persons skilled in the art. Moreover, it might be advantageous if the stainless steel plates are placed in the channels at this stage, wherein the reinforcement bars preferably will be inserted through the perforations in the steel plates.

[0064] In a seventh manufacturing step, concrete will be poured in the channels. If considered necessary, the concrete will be vibrated, a process well known by persons skilled in the art of concrete building.

[0065] In an eighth manufacturing step, the insulation layer 30 will be laid on top of the insulation layer 15 and the poured concrete forming the main bar 12, the columns 13 and the ground beam 11. The stainless steel plates will extend through this insulation layer, either through holes arranged in the insulation, or through junctions between the boards constituting the insulation layer 30.

[0066] In an eighth manufacturing step, an optional reinforcement is added on top of the insulation layer 30, whereupon concrete to form the concrete layer 31 will be poured onto the insulation layer 300.

[0067] The concrete will be left to harden for a certain amount of time, e.g. over night, after which hardening it will be possible to remove the finished wall element from the horizontal surface it has occupied.

[0068] It should be noted that the above steps could be performed without interruptions for allowing concrete to harden. It is also very beneficial that the frame 20a actually will constitute a part of the finished wall, and lastly, it is very beneficial that the frame 20a and sheet metal profiles 17 can be assembled on a location different from the location where the concrete is poured.

[0069] Consequently, it is possible to double the output from a facility manufacturing prefabricated wall elements.

[0070] Above, a prefabricated wall element a method for manufacturing a wall element according to the invention has been described. The invention is however not limited to the embodiments above, but only by the scope of the appended claims.

Claims

1. A prefabricated wall element comprising:

a first insulation layer (200; 20)
 a second insulation layer (300; 15) arranged on the first insulation layer (200; 20) and forming channels for allowing the molding of a load bearing concrete structure (13);
 a third insulation layer (400; 30) arranged such that it covers the second insulation layer (300; 15) and the load bearing concrete structure (13) and
 a concrete layer (500; 31) covering the third insulation layer (400; 30), **characterized by**
 a skeleton (100; 17) including beams (110, 120, 130) having a first side adapted for fastening of boards and a second side facing the first insulation layer (200; 20).

2. The wall element of claim 1, wherein the first insulation layer (200; 20) is made from mineral wool and wherein the second (300; 15) and third (400; 30) insulation layers are made from expanded or extruded polystyrene.

3. The wall element of claim 1 or 2, wherein the beams (110, 120, 130) of the skeleton (100) are made from profiles of sheet metal.

4. The wall element of any of the preceding claims, wherein the skeleton (100) is fastened to the load bearing concrete structure by elongate fastening means (310).

5. The wall element of claim 4, wherein the elongate fastening means (310) is a screw extending through the first insulation layer (200), from the skeleton (100) to the load bearing concrete structure.

6. Use of a wall element according to any of the preceding claims, **characterized in that** the skeleton is arranged such that it faces an indoor space of a building.

7. Use of a wall element according to any of the claims 1 to 5, **characterized in that** the concrete layer (500) is arranged such that it faces an indoor space of a building.

8. Method of manufacturing a wall element, **characterized by** the steps of:

- i. arranging a skeleton (100) comprising beams (110, 120, 130) in a mould;
- ii. covering said beams 110, 120, 130) with a first insulation layer (200);
- iii. onto said first insulation layer, applying a second insulation layer (300) defining channels adapted for molding a load bearing structure;
- iv. arranging fastening means extending from the channels, through the first insulation layer,

to the beams (110, 120, 130);

v. pouring concrete into the channels;

vi. covering said concrete and said second insulation layer (300) with a third insulation layer (400) and

5

vii. covering the third insulation layer (400) with a layer of concrete.

9. The method of claim 8, further comprising the step of:

10

viii. arranging reinforcement bars in the channels, and on the third insulation layer prior to pouring the concrete in the channels and on the third insulation layer, respectively.

15

20

25

30

35

40

45

50

55

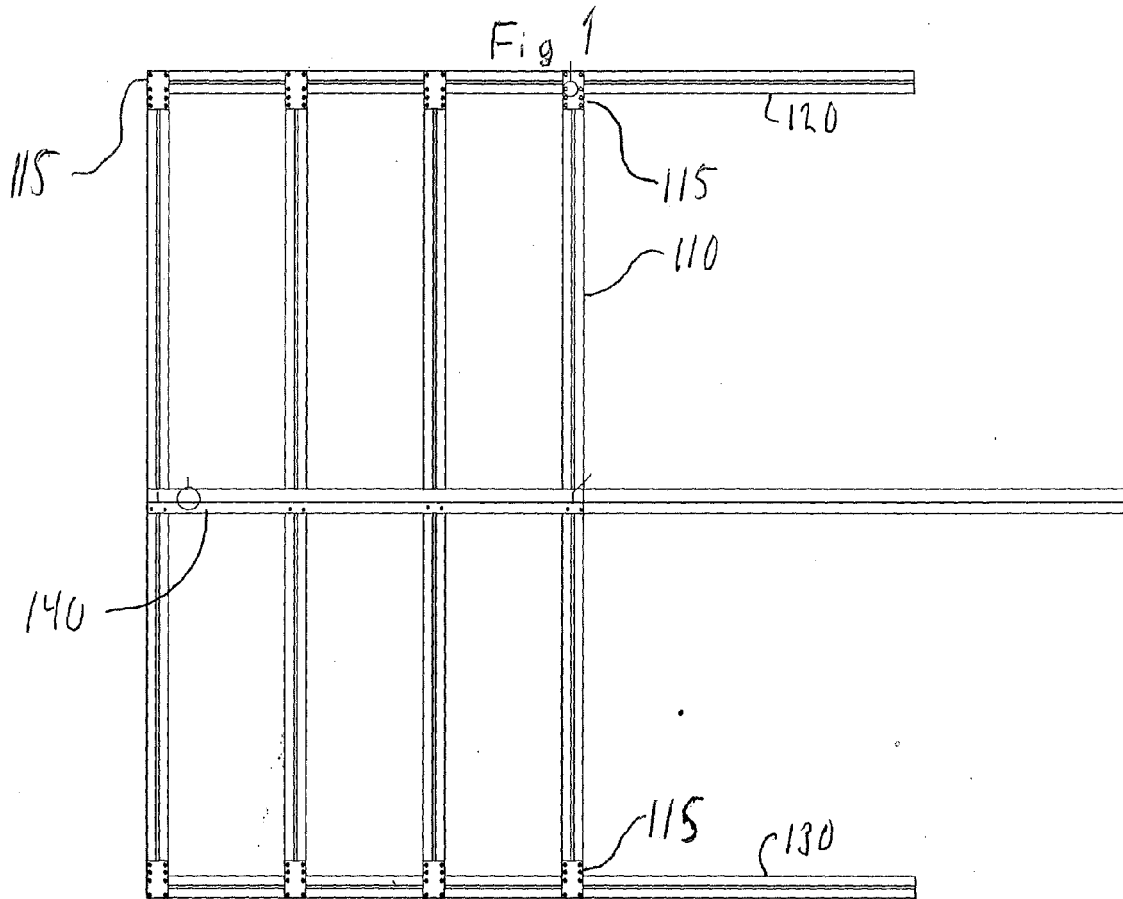

Fig. 1b



Fig. 1c

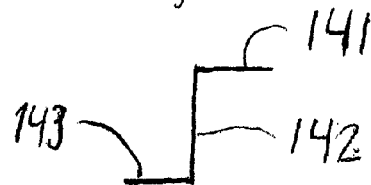
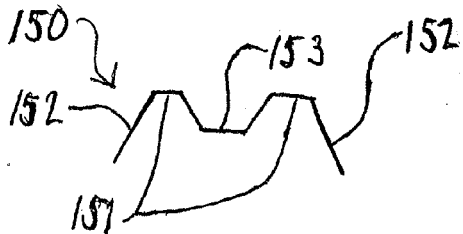

Fig. 1d



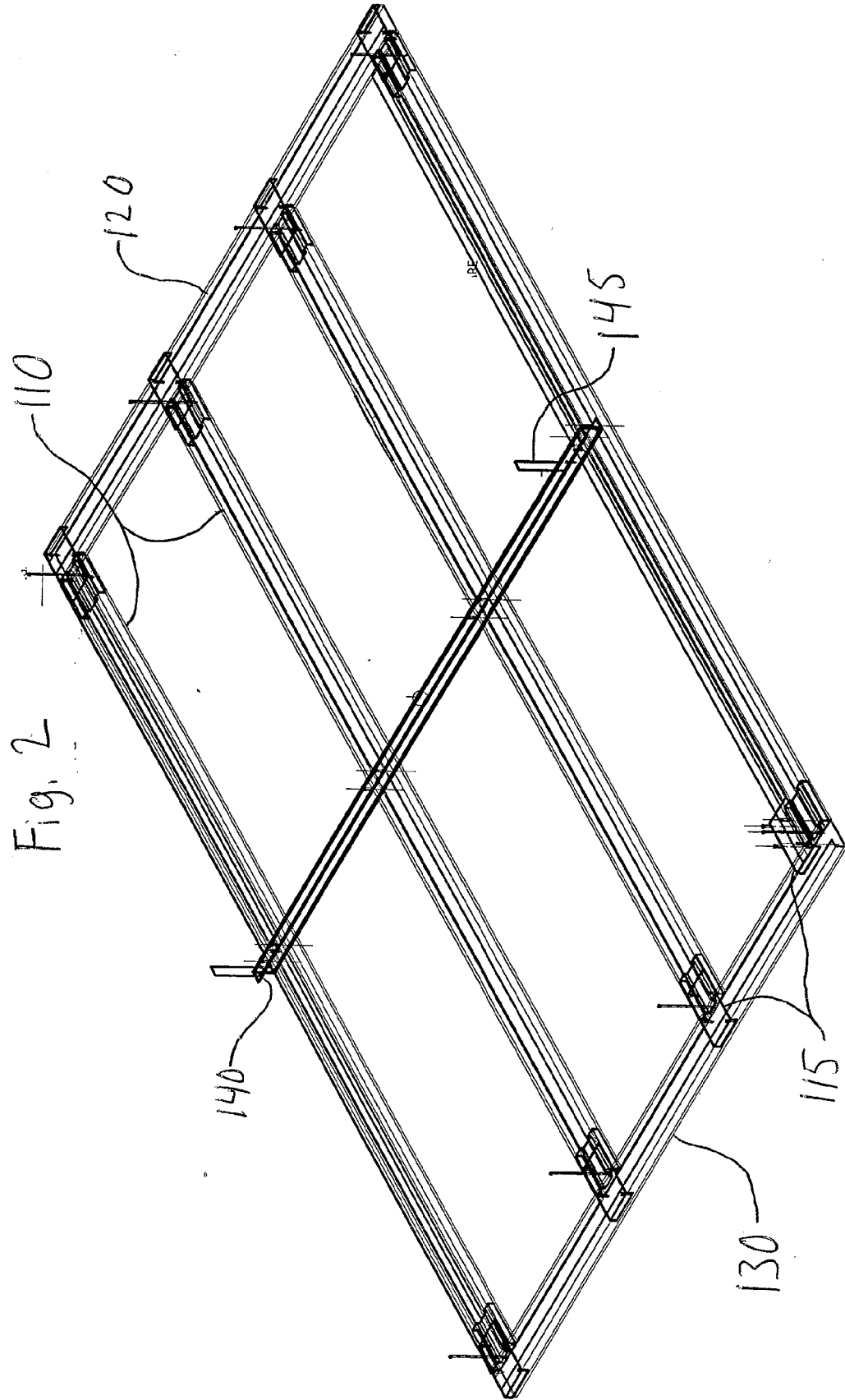
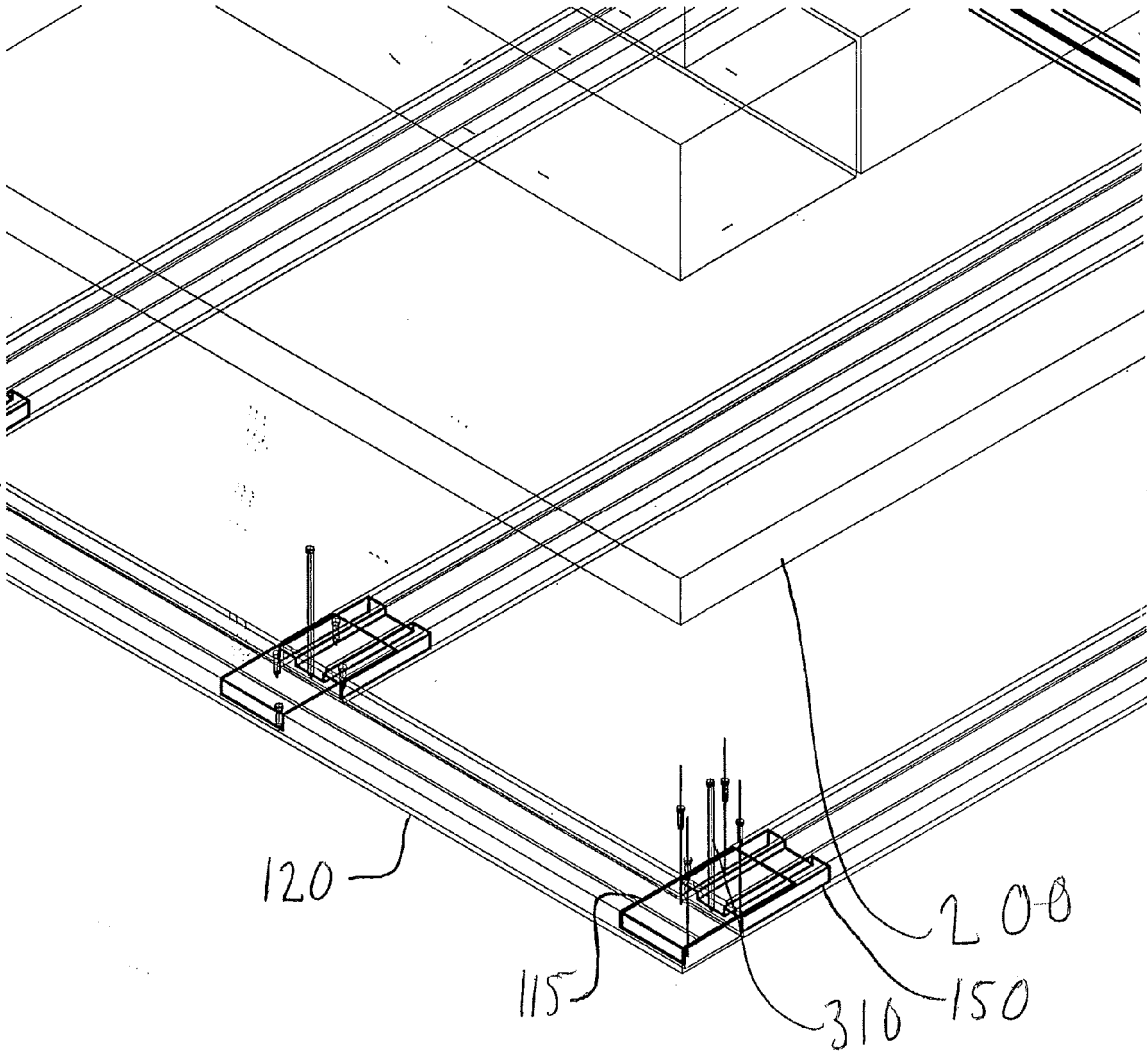

Fig. 3



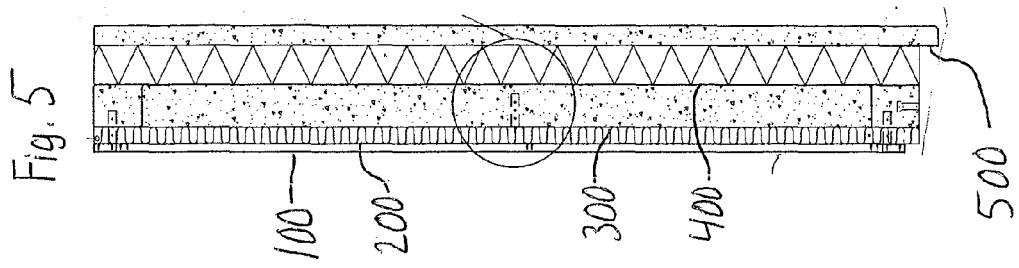
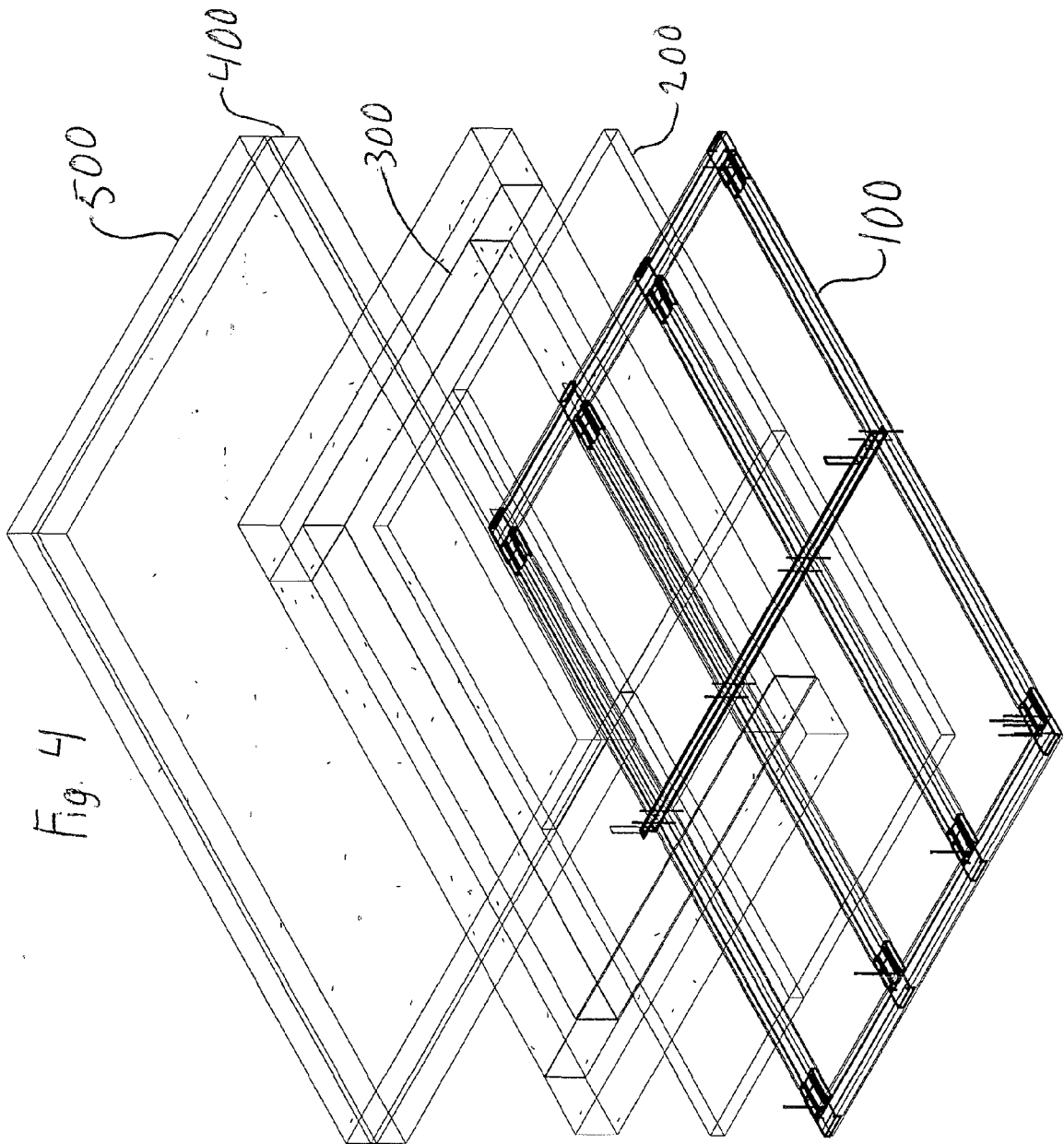

Fig. 6

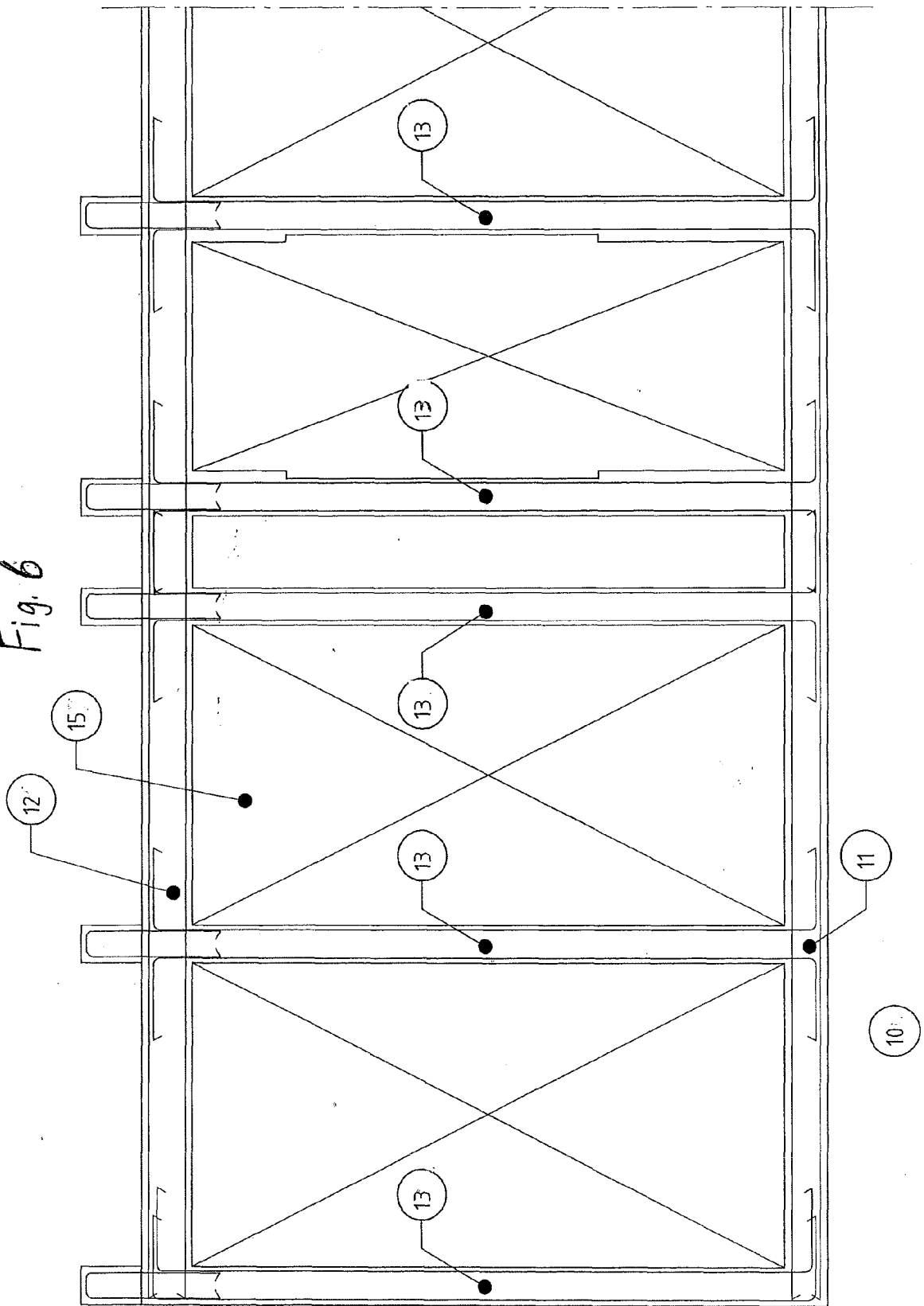
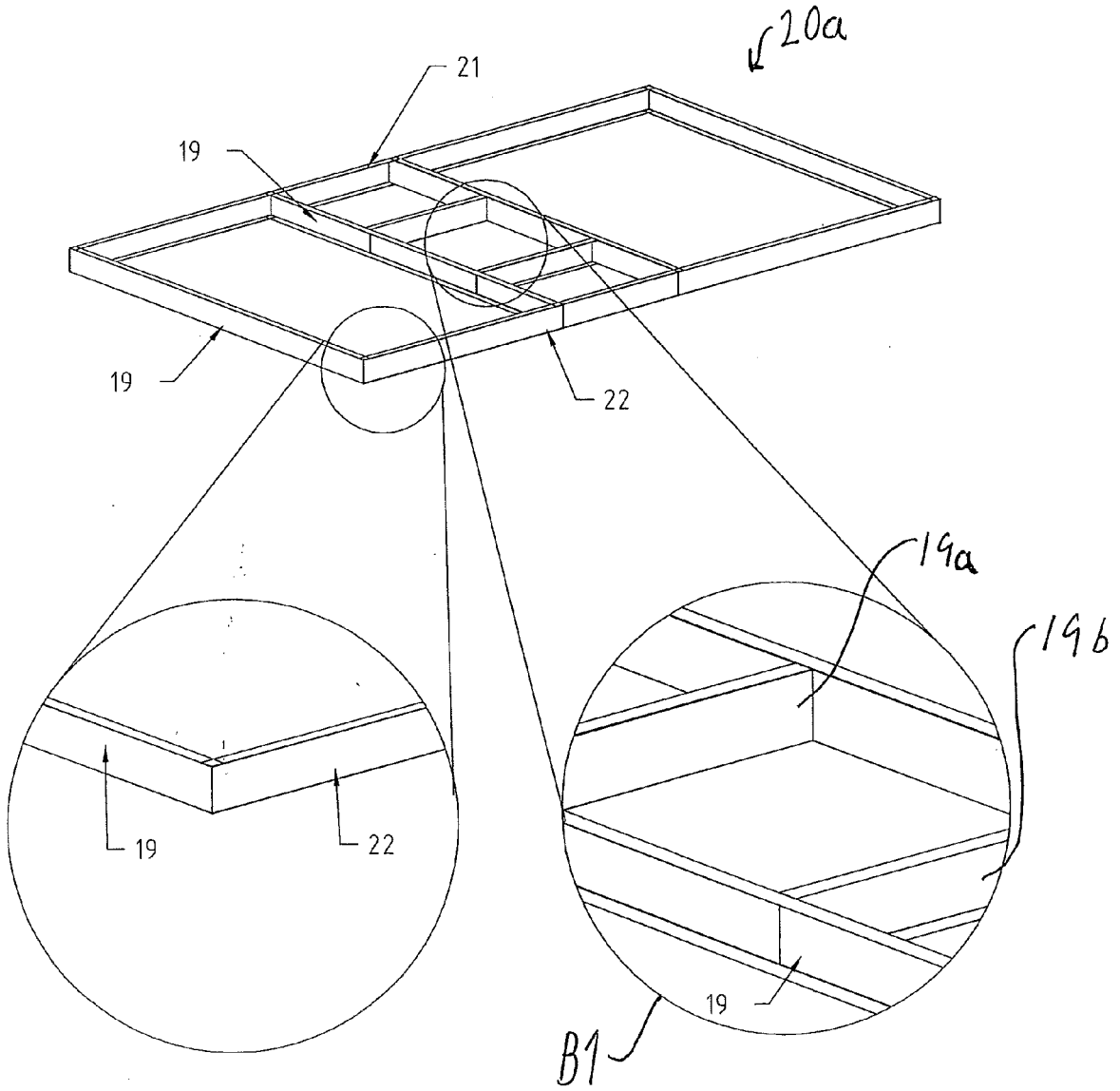

Fig. 7



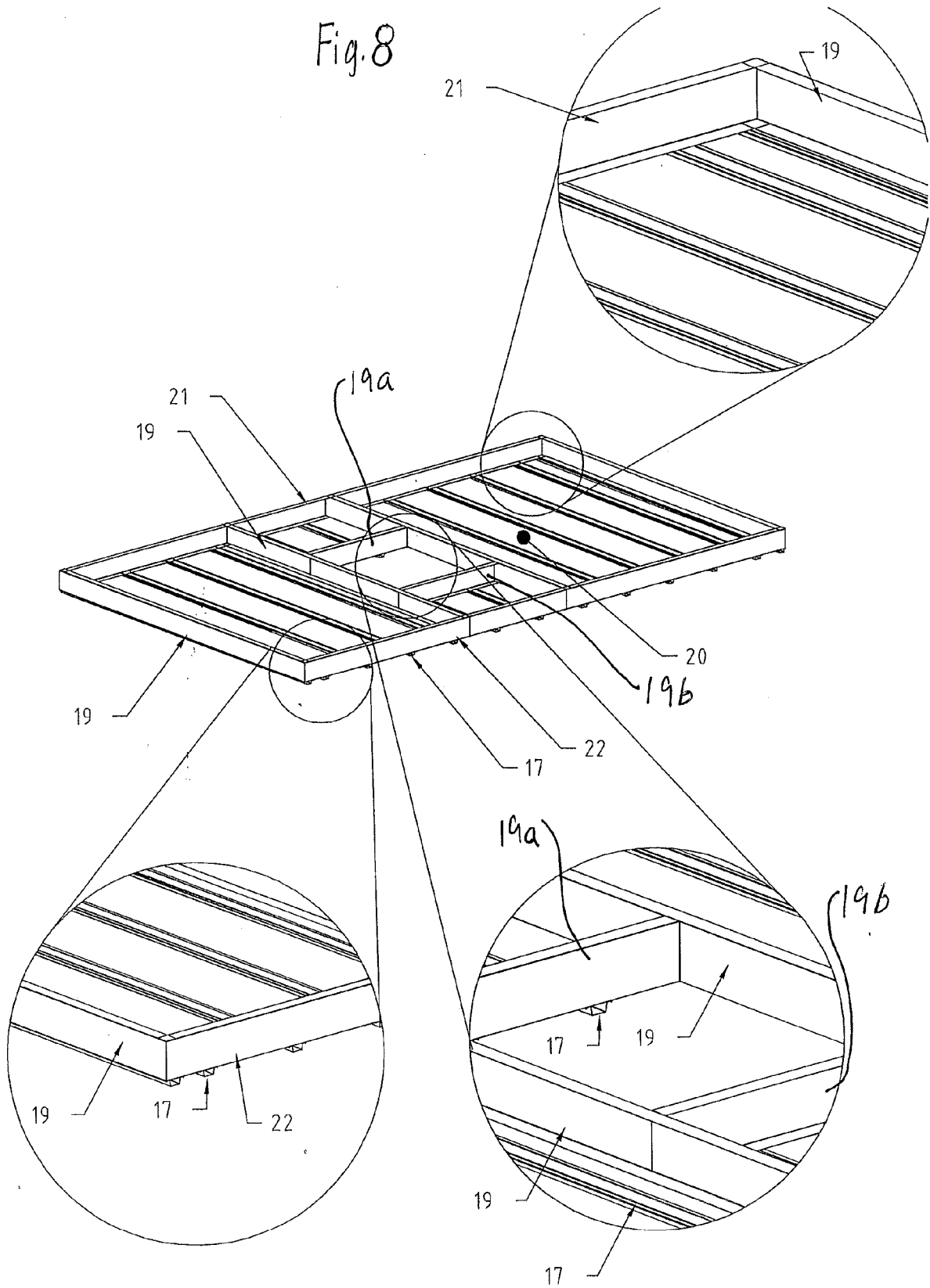
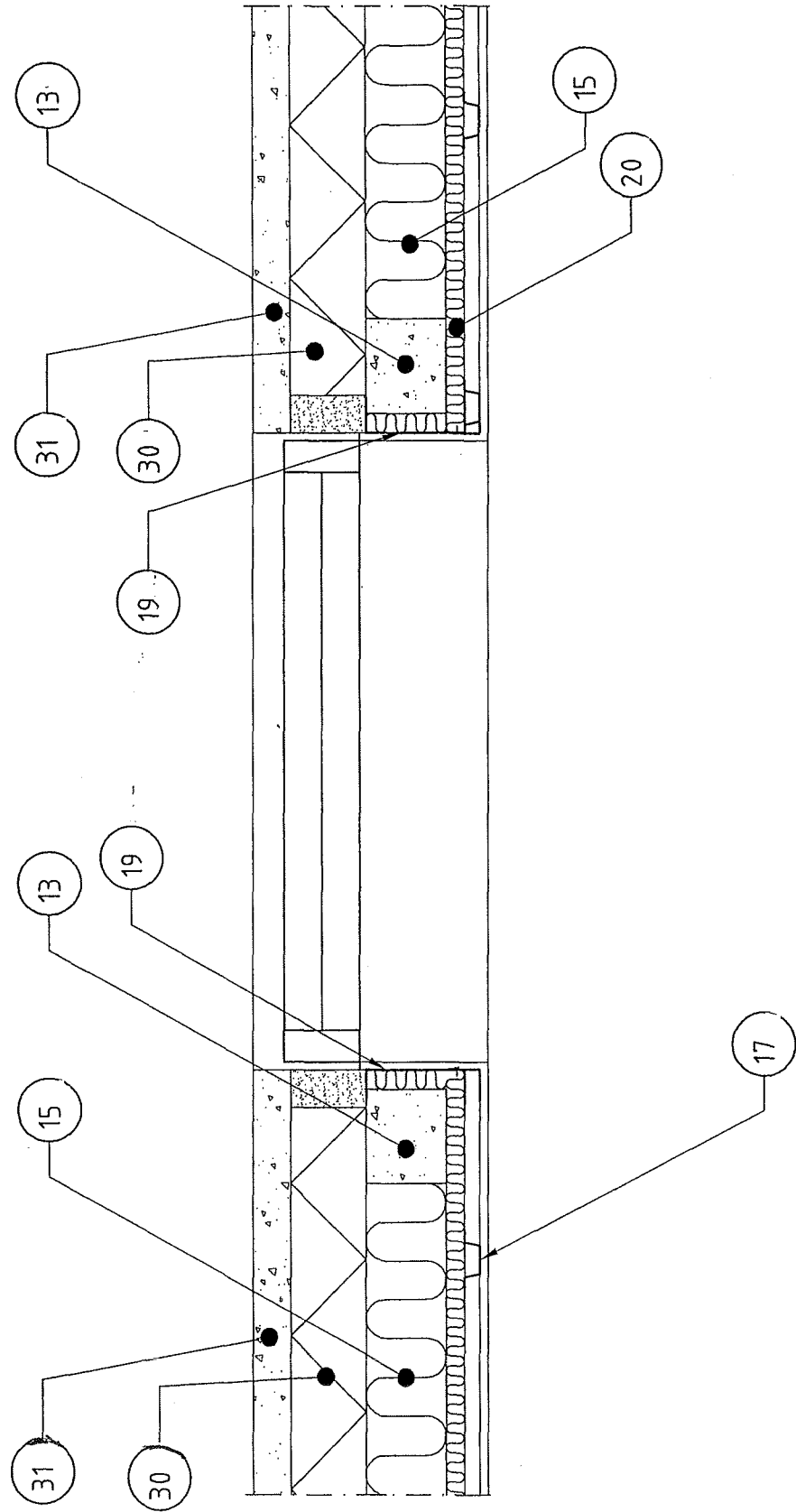

Fig. 9





Europäisches
Patentamt
European
Patent Office
Office européen
des brevets

EUROPEAN SEARCH REPORT

Application Number
EP 08 15 7652

DOCUMENTS CONSIDERED TO BE RELEVANT			
Category	Citation of document with indication, where appropriate, of relevant passages	Relevant to claim	CLASSIFICATION OF THE APPLICATION (IPC)
A	DE 20 2005 017046 U1 (GLATTHAAR FERTIGKELLER GMBH [DE]) 2 March 2006 (2006-03-02) * paragraph [0001] * * paragraph [0003] * * paragraph [0005] * * paragraph [0012] - paragraph [0014] * * paragraph [0021]; claim 1; figures 1a-d *	1-9	INV. E04C2/288 E04C2/38
A	CH 674 751 A5 (MARKUS SENN) 13 July 1990 (1990-07-13) * column 1, line 3 - line 5 * * column 1, line 29 - line 42 * * column 1, line 60 - column 2, line 3 * * column 2, line 10 - line 36; claim 1; figure 1 *	1-9	
A	EP 1 602 789 A (CHENG CHI WAI [CN]) 7 December 2005 (2005-12-07) * paragraph [0001] * * paragraph [0003] - paragraph [0005]; claim 1; figures 1,2 *	1-9	TECHNICAL FIELDS SEARCHED (IPC) E04C
A	DE 26 36 572 A1 (EUFINGER WERNER) 16 February 1978 (1978-02-16) * the whole document *	1-9	
E	EP 1 959 069 A (ICONORM GMBH [DE]) 20 August 2008 (2008-08-20) * paragraph [0001] * * paragraph [0007] * * paragraph [0009] - paragraph [0010] * * paragraph [0013] - paragraph [0015] * * paragraph [0018] * * paragraph [0024] - paragraph [0025]; claims 1,9,10; figures 2a-d *	1-9	
The present search report has been drawn up for all claims			
4	Place of search Munich	Date of completion of the search 18 February 2009	Examiner Giannakou, Evangelia
CATEGORY OF CITED DOCUMENTS		T : theory or principle underlying the invention E : earlier patent document, but published on, or after the filing date D : document cited in the application L : document cited for other reasons & : member of the same patent family, corresponding document	
X : particularly relevant if taken alone Y : particularly relevant if combined with another document of the same category A : technological background O : non-written disclosure P : intermediate document			

**ANNEX TO THE EUROPEAN SEARCH REPORT
ON EUROPEAN PATENT APPLICATION NO.**

EP 08 15 7652

This annex lists the patent family members relating to the patent documents cited in the above-mentioned European search report. The members are as contained in the European Patent Office EDP file on
The European Patent Office is in no way liable for these particulars which are merely given for the purpose of information.

18-02-2009

Patent document cited in search report	Publication date	Patent family member(s)	Publication date
DE 202005017046 U1	02-03-2006	AT 417971 T EP 1783293 A2	15-01-2009 09-05-2007
CH 674751 A5	13-07-1990	NONE	
EP 1602789 A	07-12-2005	AU 2004207164 A1 CA 2505832 A1 CN 1514086 A WO 2004067871 A1 HK 1051777 A2 US 2008115442 A1	12-08-2004 12-08-2004 21-07-2004 12-08-2004 01-08-2003 22-05-2008
DE 2636572 A1	16-02-1978	NONE	
EP 1959069 A	20-08-2008	US 2008190063 A1	14-08-2008