

AMENDED 617418

FORM 1



SPRUSON & FERGUSON

COMMONWEALTH OF AUSTRALIA

PATENTS ACT 1952

CONVENTION APPLICATION FOR A STANDARD PATENT

We, **NOVO NORDISK A/S**, of Novo Alle, DK-2880 Bagsvaerd, Denmark, hereby apply for the grant of a standard patent for an invention entitled:

APPARATUS FOR DETERMINATION OF THE COAGULATION TIME OF A BLOOD SAMPLE

which is described in the accompanying complete specification.

DETAILS OF BASIC APPLICATION

Number of Basic Application:-
157/88

Name of Convention Country in which Basic Application was filed:-
Denmark

Date of Basic Application:-
14 January 1988

The address for service is:-

Spruson & Ferguson
Patent Attorneys
Level 33 St Martins Tower
31 Market Street
Sydney New South Wales Australia

DATED this TWENTYSECOND day of MARCH 1991

NOVO NORDISK A/S

By:

Registered Patent Attorney.

TO: THE COMMISSIONER OF PATENTS

7257F/LPR

DECLARATION IN SUPPORT OF A
CONVENTION APPLICATION FOR A PATENT

In support of the Convention Application made for a
patent for an invention entitled:
Apparatus for Determination of the Coagulation
Time of a Blood Sample
I/We Anne Secher Director

Title of Invention

Full name(s) and
address(es) of
Declarant(s)

of Nordisk Gentofte A/S
Niels Steensensvej 1, DK-2820, Gentofte
Denmark

do solemnly and sincerely declare as follows:-

Full name(s) of
Applicant(s)

~~I am/We are the applicant(s) for the patent~~

(or, in the case of an application by a body corporate)

1. I am/We are authorised by Nordisk Gentofte A/S

the applicant(s) for the patent to make this declaration on
its/their behalf.

2. The basic application(s) as defined by Section 141 of the
Act was/were made

Basic Country(ies)

in Denmark

Priority Date(s)

on 14 January, 1988

Basic Applicant(s)

by Nordisk Gentofte A/S

Full name(s) and
address(es) of
inventor(s)

~~3. I am/We are the actual inventor(s) of the invention referred
to in the basic application(s)~~

(or where a person other than the inventor is the applicant)

3. Thomas Munk Plum

of Skodsborgvej 414, 3.tv, DK-2942 Skodsborg
Denmark

(respectively)

is/are the actual inventor(s) of the invention and the facts upon
which the applicant(s) is/are entitled to make the application are
as follows: Nordisk Gentofte A/S is entitled by Contract of
Employment between the inventor as employee and Nordisk
Gentofte A/S as employer, as a person who would be entitled
to have the patent assigned to it if a patent were granted
upon an application made by the inventor.

4. The basic application(s) referred to in paragraph 2 of this
Declaration was/were the first application(s) made in a Convention
country in respect of the invention the subject of the application.

Set out how Applicant(s)
derive title from actual
inventor(s) e.g. The
Applicant(s) is/are the
assignee(s) of the
invention from the
inventor(s)

Declared at Bagsvaerd this 19th day of October 19 90



Signature of Declarant(s)

To: The Commissioner of Patents

Anne Secher, Director

(12) PATENT ABRIDGMENT (11) Document No. AU-B-29448/89
(19) AUSTRALIAN PATENT OFFICE (10) Acceptance No. 617418

(54) Title
APPARATUS FOR DETERMINATION OF THE COAGULATION TIME OF A BLOOD SAMPLE

International Patent Classification(s)
(51)⁴ **G01N 033/86 G01N 021/03**

(21) Application No. : **29448/89** (22) Application Date : **29.12.88**

(87) PCT Publication Number : **WO89/06803**

(30) Priority Data

(31) Number	(32) Date	(33) Country
157/88	14.01.88	DK DENMARK

(43) Publication Date : **11.08.89**

(44) Publication Date of Accepted Application : **28.11.91**

(71) Applicant(s)
NOVO NORDISK A/S

(72) Inventor(s)
THOMAS MUNK PLUM

(74) Attorney or Agent
SPRUSON & FERGUSON , GPO Box 3898, SYDNEY NSW 2001

(56) Prior Art Documents
EP 120715

(57) Claim

1. An apparatus for the determination of the coagulation time of a blood sample comprising transparent capillary tubes of glass or plastics having an inner diameter of less than 0.5 mm for taking up samples of the blood to be tested, a photometer mounted in a housing with a measuring cell for each of the capillary tubes for the optical detection of the light permeability of the sample in the capillary tubes and a microprocessor for processing the data obtained from the photometer, said tubes being mounted in a removable support element that fits into a recess in the photometer housing.

617418

PCT

OP1 DATE 11/08/89

APPLN. ID 29448 / 89

INTERNATIONAL APPLICATI A0JP DATE 07/09/89

PCT NUMBER PCT/DK88/00224

<p>(51) International Patent Classification⁴ : G01N 33/86, 21/03</p>	<p>A1</p>	<p>(11) International Publication Number: WO 89/ 06803 (43) International Publication Date: 27 July 1989 (27.07.89)</p>
<p>(21) International Application Number: PCT/DK88/00224 (22) International Filing Date: 29 December 1988 (29.12.88) (31) Priority Application Number: 157/88 (32) Priority Date: 14 January 1988 (14.01.88) (33) Priority Country: DK (71) Applicant (for all designated States except US): NORDISK GENTOFTE A/S ^{NOVO NORDISK A/S} [DK/DK]; Niels Steensensvej 1, DK-2820 Gentofte (DK). (72) Inventor; and (75) Inventor/Applicant (for US only) : PLUM, Thomas, Munk [DK/DK]; Skodsborgvej 414, 3.tv., DK-2942 Skodsborg (DK). (74) Agent: LARSEN & BIRKEHOLM A/S SKANDINAVISK PATENTBUREAU ; Skagensgade 64, DK-2630 Taastrup (DK).</p>		<p>(81) Designated States: AT, AT (European patent), AU, BB, BE (European patent), BG, BJ (OAPI patent), BR, CF (OAPI patent), CG (OAPI patent), CH, CH (European patent), CM (OAPI patent), DE, DE (European patent), DK, FI, FR (European patent), GA (OAPI patent), GB, GB (European patent), HU, IT (European patent), JP, KP, KR, LK, LU, LU (European patent), MC, MG, ML (OAPI patent), MR (OAPI patent), MW, NL, NL (European patent), NO, RO, SD, SE, SE (European patent), SN (OAPI patent), SU, TD (OAPI patent), TG (OAPI patent), US.</p> <p>Published With international search report. In English translation (filed in Danish).</p> 

(54) Title: APPARATUS FOR DETERMINATION OF THE COAGULATION TIME OF A BLOOD SAMPLE

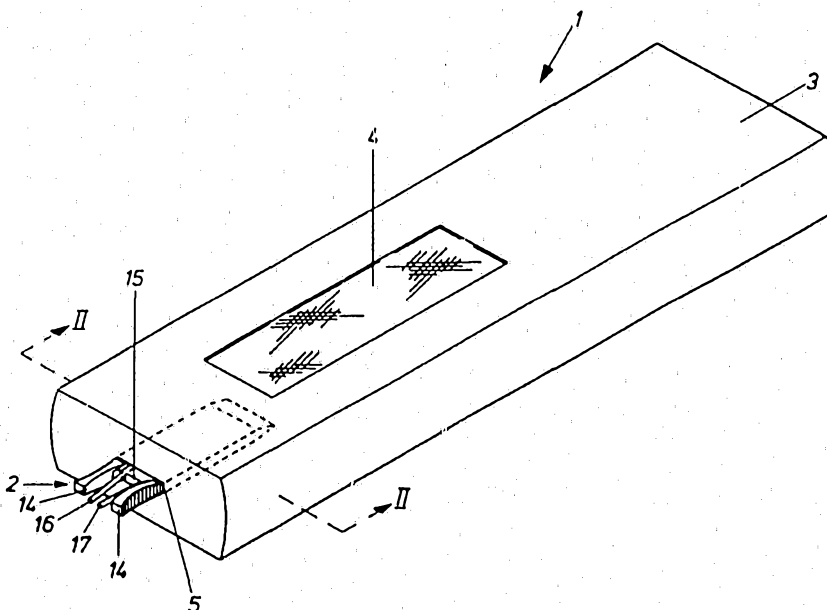

(57) Abstract

With a blood measuring apparatus according to the invention, which uses capillary tubes (16, 17), these can be filled with blood from a drop of blood of about 1 microlitre. This small amount of blood can be produced by the pricking of a finger. The blood sample can then be placed in an apparatus (1) with equipment for the determination of the blood by transillumination. The tubes (16, 17) are mounted in an independent plate piece (6), and the tubes are secured in V-form so that the inlet ends lie closely up against each other. This provides the possibility of filling two tubes at the same time, and herewith the possibility of simultaneous determination of one's own blood and a comparison with blood in, for example, a prepared tube.

**APPARATUS FOR DETERMINATION OF THE COAGULATION
TIME OF A BLOOD SAMPLE**

The invention relates to an apparatus for the measuring of a blood sample, and comprising transparent capillary elements for taking up the blood, and a housing-mounted photometer with measuring cells for the optical detection of the light permeability of the sample in the capillary element, and which is connected to a computer for the determination of the coagulation time of the sample.

10 Apparatus of this kind is used particularly by haemophilia patients for measuring the coagulability of the blood, and hereby for the determination of whether there is need for the injection of a factor VIII preparation in order to avoid haemorrhages.

15 Equipment of this kind is known from EP publication No. 120 715. Here, the capillary element consists of a measuring cell in the form of an elongated channel at the end of a holder. Blood is sucked up into the channel, and the measuring cell can hereafter be inserted into a measuring apparatus with
20 a light source and a photometer. The photometer measures the amount of light which, after the emission, passes the transparent side of the measuring cell, and which after reflection in the blood and the back of the measuring cell again passes through the transparent side.

25 This measuring cell does not, however, provide an accurate measurement result, the reason being that it is based on reflection. This gives rise to a measurement inaccuracy which is so great that it is unsuitable for the measurement of the coagulability of the blood. Furthermore, it is difficult to
30 produce such a measuring cell, the reason being that the capillary element is built up of at least two parts which must be assembled for the formation of an element.

From the Swedish publication No. 404 260, an apparatus is known which can measure with greater accuracy, since this
35 uses a beam of light and light detecting elements which are



placed at an angle in relation to the light's direction of incidence in the sample.

However, this apparatus demands a precisely balanced positioning of these measuring means in relation to the blood sample, and in practice
5 this means that the blood must be kept in a vessel-like container during the measurement. Since at a minimum there must be sufficient blood to cover the light detectors, a considerable amount of blood is required. This is a serious drawback for the user, the reason being that such a
10 large amount of blood in practice can be obtained only with the help of a suction pump and hypodermic. Therefore, this apparatus is not suitable for so-called home use, where the user himself must be able to remove the blood sample necessary for a measurement.

It is the object of the invention to ameliorate these deficiencies and disadvantages of the known kinds of apparatus.

15 Accordingly, this invention in one broad form provides an apparatus for the determination of the coagulation time of a blood sample comprising transparent capillary tubes of glass or plastics having an inner diameter of less than 0.5 mm for taking up samples of the blood to be tested, a photometer mounted in a housing with a measuring cell for
20 each of the capillary tubes for the optical detection of the light permeability of the sample in the capillary tubes and a microprocessor for processing the data obtained from the photometer, said tubes being mounted in a removable support element that fits into a recess in the photometer housing.

25 The accuracy of measurement achieved hereby is considerably increased, since one can transilluminate the blood in the tube transversely to said tube. This reduces the measurement inaccuracy, the reason being that the tube can be produced with precise dimensions and of a homogenous material. This makes it well-suited for use in the
30 measurement of the coagulability of the blood.

Furthermore, for reasons of the small internal diameter of the tube, a considerably smaller amount of blood is required in relation to the known types of measuring apparatus. For the filling of a tube length of, for example, 30 mm, less than 1 microlitre is required. In practice, a drop of blood procured by, for example, the pricking of a finger, could fill several tubes, which provides the possibility of filling, for example, a prepared and an unprepared tube from one and the same drop of blood.

The apparatus thus becomes convenient to use, in that it is simple and quick to remove and take up a drop of blood in the tubes for use in the measurement.

By mounting the tubes on an independent support element, e.g. in the form of a plate piece, these can easily be handled and filled and placed in the measuring apparatus in a well defined position opposite the photometer.

A preferred support element having two capillaries permits simultaneous double determination of the coagulation time of a blood sample.

By providing openings in the support piece opposite the tubes, as disclosed in claim 3, the passage of light through the blood will easily be ensured by placing light sources and detectors on each side of the opening in the apparatus.

By allowing the one end of the tubes to extend some distance outside the plate piece itself, as disclosed in claim 4, it will be a simple matter to place the tube ends in the drop of blood.

By allowing the tube ends to lie closely up against each other, as disclosed in claim 5, one will be able to fill several tubes from a single drop of blood.

By allowing the tubes to be placed in a fan-shaped manner, as disclosed in claim 6, it will be possible to transilluminate several tubes at a time in the apparatus, without any danger of the measurements being mutually influenced.

By providing the support piece with an extension on each side around the tube ends, as disclosed in claim 7, one will be able to hold the element between two fingers, and also to use the extensions as support, for example against the skin of the finger, during the taking up
5 of the blood.

The invention will now be described in closer detail with reference to the drawings, wherein:

Fig. 1 shows a perspective illustration of an apparatus with support element inserted,

10 Fig. 2 shows a cross-sectional drawing of the apparatus seen in the direction II-II in Fig. 1,

Fig. 3 shows the support element seen from the side during the filling of the tubes from a finger,

Fig. 4 shows the support element seen from the opposite side,

15 Fig. 5 shows a block diagram of the measuring equipment in the apparatus,

Fig. 6 shows a graph of the translucency D in normal blood as a function of the time t , and

20 Fig. 7 shows a corresponding graph for the blood of a haemophilia patient.

In Fig. 1 is shown an example of a preferred embodiment of an apparatus according to the invention.

The measuring apparatus itself is indicated as a whole by the reference figure 1. It comprises a housing 3 with a display 4 on the one
25 side.

At the one end of the housing 3 there is provided a slot opening 5 in which a support element with capillary tubes, which is shown as a whole by the reference figure 2, can be inserted, as shown in Fig. 1.



As shown in fig. 2, one or more light sources 7, 9, preferably in the form of light diodes, are mounted in the one part of the housing 3 in relation to the slot opening 5, plus a light meter, preferably in the form of a photodiode 8, 10, is mounted in the other part of the housing in relation to the slot opening.

The apparatus is also provided with a built-in but not shown microprocessor, which is connected as illustrated in the block diagram shown in fig. 5.

10 In this diagram, the apparatus itself is indicated by the block 22, which is connected to an analog/digital converter 23 which converts the signal from the photodiodes 8, 10 to a figure which is read into a microprocessor 24. This is arranged to analyse the signal from the measurement and to supply pulses
15 to a display 25 on the apparatus, which in fig. 1 is indicated by the reference figure 4.

By depicting the signal from this photometer as a function of time, a diagram as shown in figs. 6 and 7 is obtained.

20 Blood with a normal coagulation characteristic will, after a period of time, in the example in fig. 6 after approx. 5 mins., show a markedly decreasing light permeability for reasons of the coagulation of the blood.

As shown in fig. 7, such a marked decrease does not
25 appear with blood from a haemophilia patient.

Therefore, the blood's permeability to light can be used for the determination of the coagulation time, and hereby for indication of the need for an injection of a factor VIII preparation.

30 When a blood sample is thus placed in a capillary element between the light sources 7, 9 and the photodiodes 8, 10 in an apparatus 1, from the display 4 one will be able to read the period of time which it takes for the blood to begin to coagulate, and which corresponds to the turning point in the
35 graph shown in fig. 6.



As shown in figs. 3 and 4, the capillary element according to the invention comprises a support piece 6, which is preferably made of an opaque plastic. This is in the form of a plate which, as shown at its one end, is tapered to form a wedge 13 for easy insertion into the slot 5 in the apparatus.

At the opposite end of the plate piece, a pair of extensions are provided in the form of legs 14, the outer sides of which are slightly concave and provided with small serrations for easy handling during operation.

Moreover, the top and bottom sides of the plate piece are provided with a pair of grooves or guide tracks 11, 12 to ease the guiding of the plate during insertion into the apparatus.

Finally, on the one side there are formed two recesses which extend at a mutual angle, and in which a glass or plastic capillary tube 16, 17 can be secured, for example by glueing. Moreover, at a suitable place in each recess there is a through-going opening 18, 19.

When the support element 2 is inserted in the apparatus, the openings 18, 19 must be placed precisely opposite the light diodes and the photodiodes as shown in fig. 2.

As shown in figs. 3 and 4, the capillary tubes 16, 17 project for a distance beyond the plate edge 15, and also a small distance beyond the ends of the legs 14.

Glass is well-suited for the tube, the reason being that its electro-negative characteristics ensure a uniform starting time for the coagulation of the blood. Furthermore, an internal diameter of about 0.2 mm will be sufficient to ensure that the result of the measurement is reliable. If the glass has a length of approx. 30 mm, its capacity will be about 1 micro-litre. It is of great importance that more blood is not demanded, in that one can hereby carry out a blood test on the basis of a single drop of blood.

As shown in fig. 3, the blood sample can be taken from a drop 21 on a finger 20, which is first pricked e.g. by means of a not-shown lancet. When the drop of blood has been formed,

the support element 2, held by means of two fingers against the legs 14, is brought to bear against the finger so that the ends of the tubes 16, 17 are dipped in the blood. Hereafter, blood is taken up into the tubes 16, 17 in such an amount that it fills out the tubes opposite the openings 18, 19.

The support element 2 is then conveyed to the measuring apparatus, where it is inserted in the opening 5.

After the insertion, the measuring procedure commences and, after a short period of time, the measuring apparatus registers the time at which the coagulation starts, and shows this time on the display 4. In this simple manner, the patients themselves can measure their blood and decide whether there is need for an injection.

Where the user has difficulty in handling the relatively small support element 2, it can be of advantage to insert the element into the measuring apparatus before taking the blood sample, and thereafter apply the apparatus and therewith the support element with the tubes down on the drop of blood. In this way, one can more easily handle and control the support element while taking the blood sample.

After the measurement, the support element with the blood sample can be removed and discarded, in that the support element is a disposable product to simplify the operation and at the same time ensure the greatest possible hygiene.

One of the tubes 16, 17 can be provided with an internal coating of a material, e.g. a factor VIII preparation, the concentration of which is desired to be measured in the blood and compared with that blood which has been taken up into the second tube. This second tube is not provided with an internal coating, and is therefore a dry tube which will contain the patient's own blood. A patient can hereby simultaneously determine his blood's factor VIII concentration.

In the foregoing, the displaying of the result of the measurement has been discussed only in the form of a time-related indication, but it lies within the scope of the invention to use other corresponding parameters for the



determination of factors which are of importance for the result of the analysis.

SECRET

SECRET

SECRET

MTS

The claims defining the invention are as follows:

1. An apparatus for the determination of the coagulation time of a blood sample comprising transparent capillary tubes of glass or plastics having an inner diameter of less than 0.5 mm for taking up samples of the blood to be tested, a photometer mounted in a housing with a measuring cell for each of the capillary tubes for the optical detection of the light permeability of the sample in the capillary tubes and a microprocessor for processing the data obtained from the photometer, said tubes being mounted in a removable support element that fits into a recess in the photometer housing.

2. An apparatus according to claim 1, wherein said support element has two capillary tubes.

3. An apparatus according to claim 1 or 2, wherein said support element has apertures through it, each aperture exposing a said tube such that the measuring cells can detect the light permeability of the blood sample in the tubes.

4. An apparatus according to claim 1 or 2, wherein each said tube in said support element has an inlet end which projects beyond the adjacent end of the support element.

5. An apparatus according to claim 4 characterized in that the inlet ends of said tubes are positioned close to each other.

6. An apparatus according to claims 1 or 2, wherein the tubes in the support element diverge from each other from their inlet ends to their outlet ends.

7. An apparatus according to claim 1 or 2, wherein the support element has a pair of fingergrrips in the form of legs that project from the support element, one on each side of the tubes.

8. Apparatus for determining the coagulation time of a blood sample, substantially as described herein with reference to Figs. 1 to 5 of the accompanying drawings.

DATED this FOURTH day of SEPTEMBER 1991

Novo Nordisk A/S

Patent Attorneys for the Applicant
SPRUSON & FERGUSON

MTS

RLF/1433h

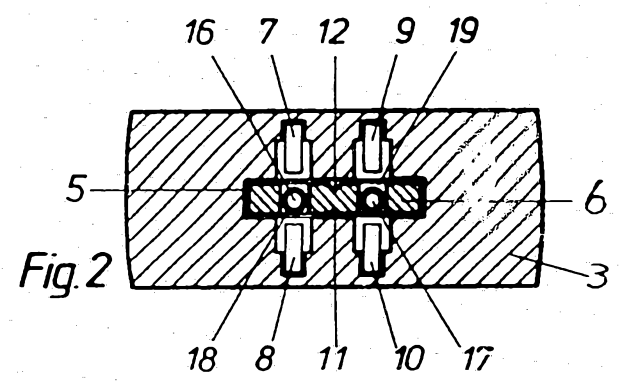
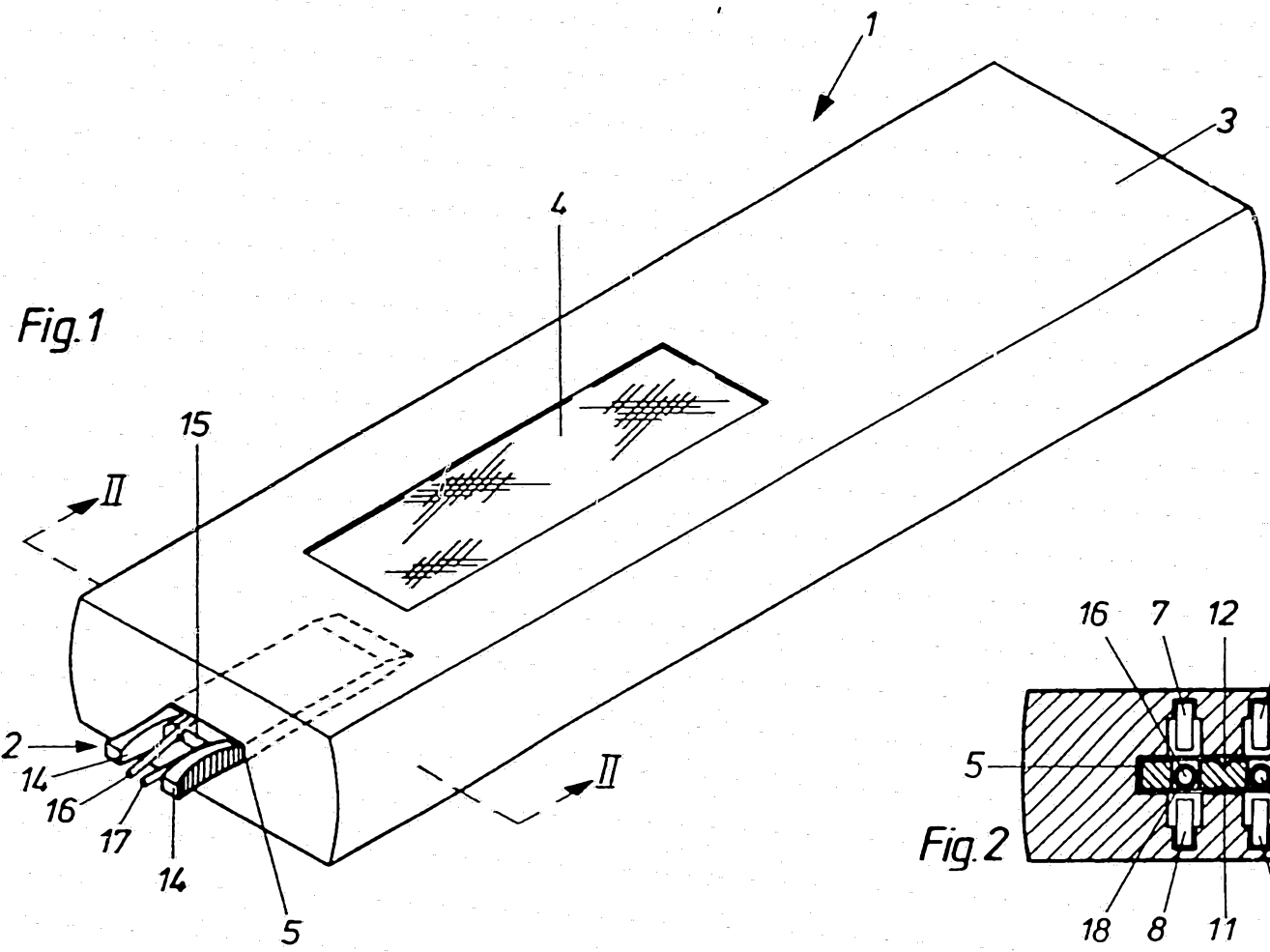

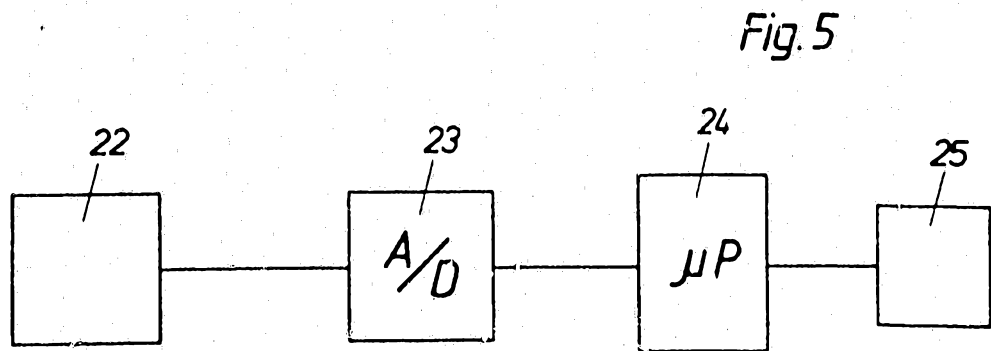
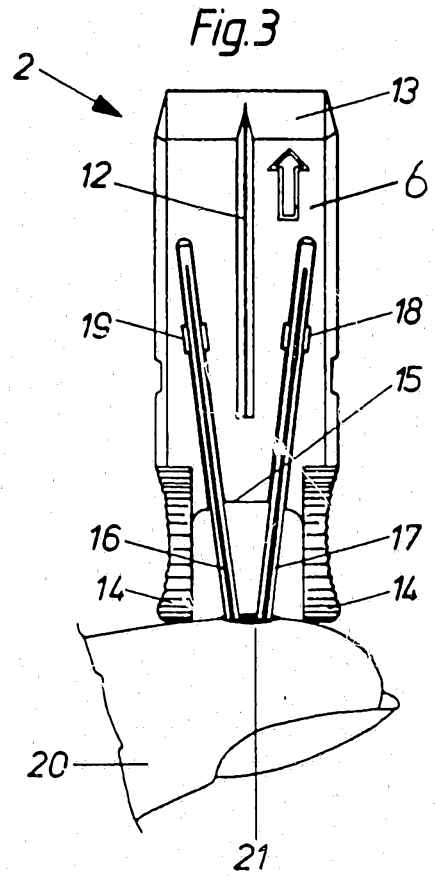
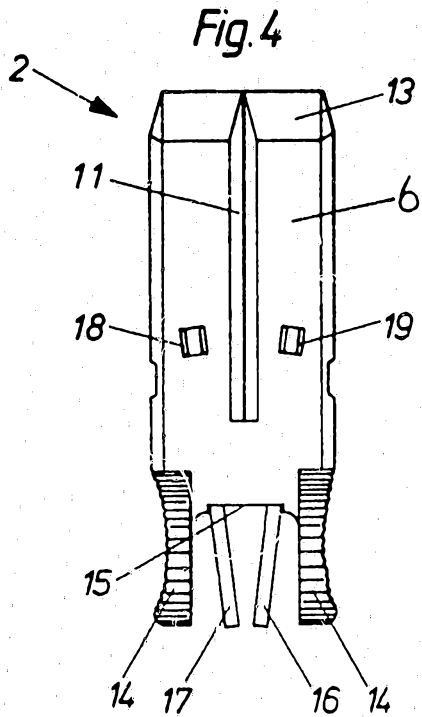

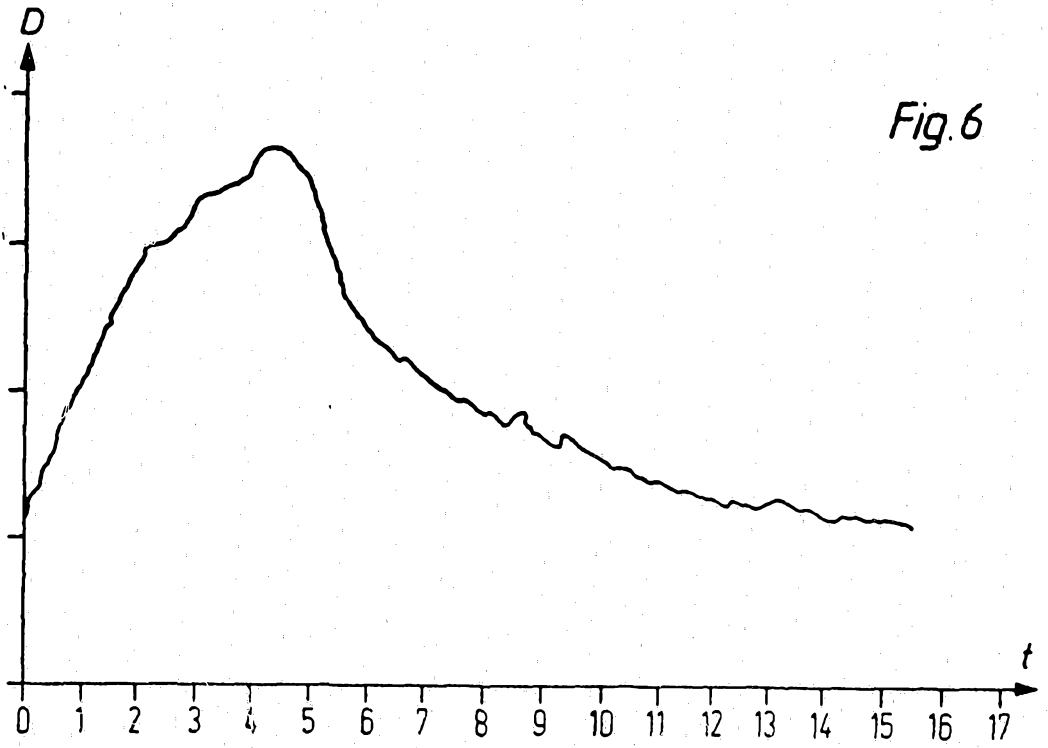

Fig. 6

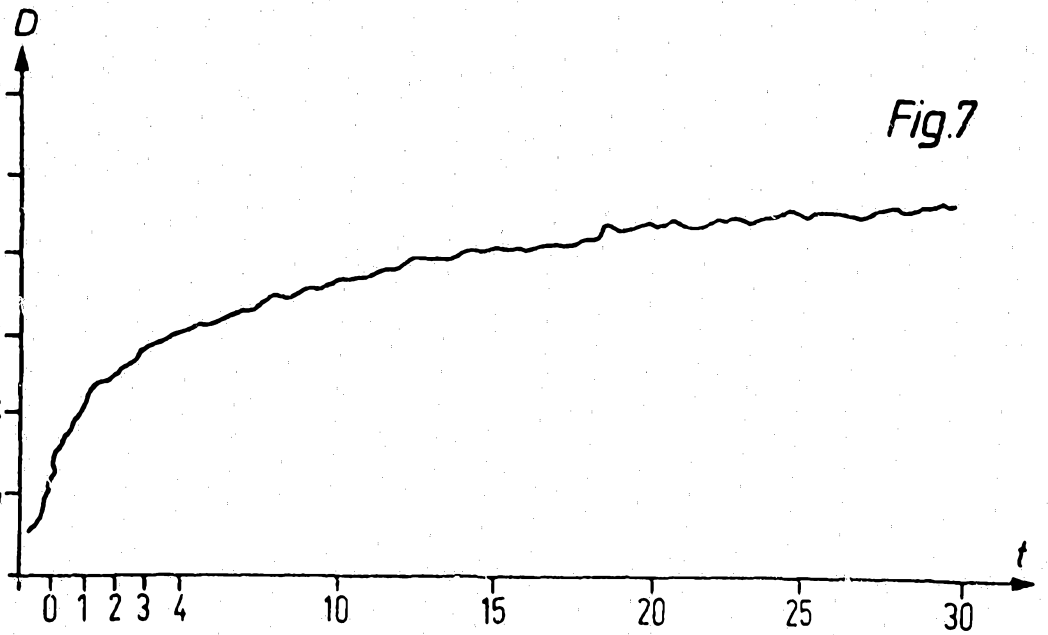
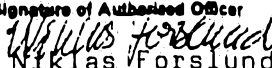

Fig. 7

INTERNATIONAL SEARCH REPORT

International Application No PCT/DK88/00224

I. CLASSIFICATION OF SUBJECT MATTER (if several classification symbols apply, indicate all) ⁶		
According to International Patent Classification (IPC) or to both National Classification and IPC ₄		
G 01 N 33/86, G 01 N 21/03		
II. FIELDS SEARCHED		
Minimum Documentation Searched ⁷		
Classification System	Classification Symbols	
IPC 4	G 01 N; C 12 M; C 12 Q	
Documentation Searched other than Minimum Documentation to the Extent that such Documents are Included in the Fields Searched ⁸		
SE, NO, DK, FI classes as above.		
III. DOCUMENTS CONSIDERED TO BE RELEVANT ⁹		
Category ¹⁰	Citation of Document, ¹¹ with indication, where appropriate, of the relevant passages ¹²	Relevant to Claim No. ¹³
Y	A Wiley Biomedical Publication, 1976, Vurek, G, Bowman, R, "Assay Methods Using Capillary Tubes", Mario Werner, M.D., John Wiley & Sons pp 55-64. See in particular p 59, col 1, lines 15-28	1
Y	EP, A2, 0 120 715 (HYSLOP, CHRISTOPHER PAUL) 3 October 1984 See in particular the abstract.	1
Y	SE, B, 404 260 SWELAB INSTRUMENT AB) 25 September 1978 See in particular the claims and the figure	1
<p>¹⁰ Special categories of cited documents: ¹⁰</p> <p>"A" document defining the general state of the art which is not considered to be of particular relevance</p> <p>"E" earlier document but published on or after the international filing date</p> <p>"L" document which may throw doubt on priority claim(s) or which is cited to establish the publication date of another citation or other special reason (as specified)</p> <p>"O" document referring to an oral disclosure, use, exhibition or other means</p> <p>"P" document published prior to the international filing date but later than the priority date claimed</p> <p>"T" later document published after the international filing date or priority date and not in conflict with the application but cited to understand the principle or theory underlying the invention</p> <p>"X" document of particular relevance; the claimed invention cannot be considered novel or cannot be considered to involve an inventive step</p> <p>"Y" document of particular relevance; the claimed invention cannot be considered to involve an inventive step when the document is combined with one or more other such documents, such combination being obvious to a person skilled in the art.</p> <p>"A" document member of the same patent family</p>		
IV. CERTIFICATION		
Date of the Actual Completion of the International Search	Date of Mailing of this International Search Report	
1989-04-07	1989-04-17	
International Searching Authority	Signature of Authorized Officer	
Swedish Patent Office	 Niklas Forslund	