

(19) World Intellectual Property Organization  
International Bureau



(43) International Publication Date  
22 March 2007 (22.03.2007)

PCT

(10) International Publication Number  
**WO 2007/033183 A1**

(51) International Patent Classification:  
B65D 81/34 (2006.01)

(74) Agents: ISAF, Louis, T. et al.; WOMBLE CARLYLE SANDRIDGE & RICE, PLLC, P.o. Box 7037, Atlanta, GA 30357-0037 (US).

(21) International Application Number:  
PCT/US2006/035503

(81) Designated States (unless otherwise indicated, for every kind of national protection available): AE, AG, AL, AM, AT, AU, AZ, BA, BB, BG, BR, BW, BY, BZ, CA, CH, CN, CO, CR, CU, CZ, DE, DK, DM, DZ, EC, EE, EG, ES, FI, GB, GD, GE, GH, GM, HN, HR, HU, ID, IL, IN, IS, JP, KE, KG, KM, KN, KP, KR, KZ, LA, LC, LK, LR, LS, LT, LU, LV, LY, MA, MD, MG, MK, MN, MW, MX, MY, MZ, NA, NG, NI, NO, NZ, OM, PG, PH, PL, PT, RO, RS, RU, SC, SD, SE, SG, SK, SL, SM, SV, SY, TJ, TM, TN, TR, TT, TZ, UA, UG, US, UZ, VC, VN, ZA, ZM, ZW.

(22) International Filing Date:  
12 September 2006 (12.09.2006)

(25) Filing Language: English

(26) Publication Language: English

(30) Priority Data:  
60/716,262 12 September 2005 (12.09.2005) US  
60/723,827 5 October 2005 (05.10.2005) US  
60/724,196 6 October 2005 (06.10.2005) US  
60/736,442 14 November 2005 (14.11.2005) US

(84) Designated States (unless otherwise indicated, for every kind of regional protection available): ARIPO (BW, GH, GM, KE, LS, MW, MZ, NA, SD, SL, SZ, TZ, UG, ZM, ZW), Eurasian (AM, AZ, BY, KG, KZ, MD, RU, TJ, TM), European (AT, BE, BG, CH, CY, CZ, DE, DK, EE, ES, FI, FR, GB, GR, HU, IE, IS, IT, LT, LU, LV, MC, NL, PL, PT, RO, SE, SI, SK, TR), OAPI (BF, BJ, CF, CG, CI, CM, GA, GN, GQ, GW, ML, MR, NE, SN, TD, TG).

(71) Applicant: GRAPHIC PACKAGING INTERNATIONAL, INC. [US/US]; 814 Livingston Court, Marietta, GA 30067 (US).

Published:  
— with international search report

(72) Inventors: RUSSELL, Mitchell, W.; 2 Brodeur Street, Penacook, NH 03303 (US). LIU, Bing; 133 Kirknewton Road, Ontario M6E 3Y3 (CA). LAI, Laurence, M., C.; 887 The Greenway, Mississauga, Ontario L5G 1P7 (CA).

For two-letter codes and other abbreviations, refer to the "Guidance Notes on Codes and Abbreviations" appearing at the beginning of each regular issue of the PCT Gazette.

(54) Title: ELEVATED MICROWAVE HEATING CONSTRUCT

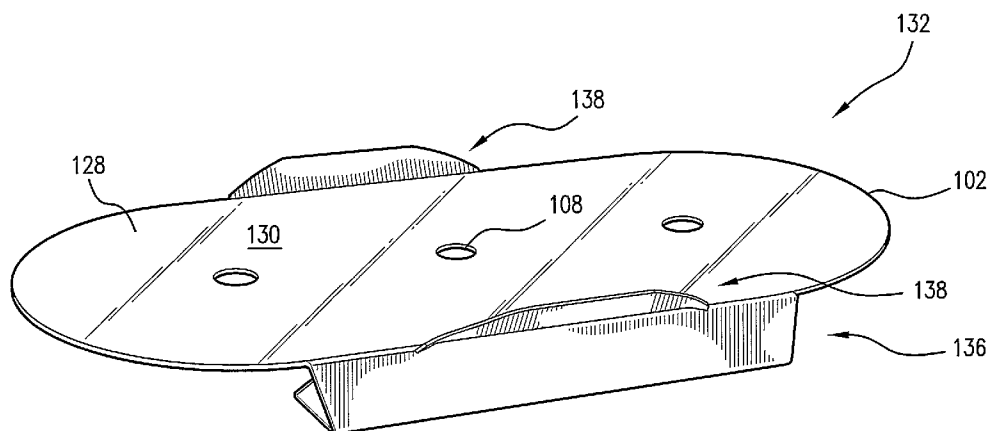

(57) Abstract: Various blanks and constructs formed therefrom are provided. The various constructs include features for supporting a food item at an elevated position to enhance the heating, browning, and/or crisping of the food item in a microwave oven.

WO 2007/033183 A1

## ELEVATED MICROWAVE HEATING CONSTRUCT

### CROSS-REFERENCE TO RELATED APPLICATIONS

This application claims the benefit of U.S. Application No. 60/716,262, filed September 12, 2005; U.S. Application No. 60/723,827, filed October 5, 2005; U.S. Application No. 60/724,196, filed October 6, 2005; and U.S. Application No. 60/736,442, filed November 14, 2005, each of which is incorporated by reference hereby in its entirety.

### TECHNICAL FIELD

The present invention relates to various blanks, constructs, and methods for heating, browning, and/or crisping a food item, and particularly relates to various blanks, constructs, and methods for heating, browning, and/or crisping a food item in a microwave oven.

### BACKGROUND

Microwave ovens provide a convenient means for heating a variety of food items, including dough-based products such as pizzas and pies. However, microwave ovens tend to cook such items unevenly and are unable to achieve the desired balance of thorough heating and a browned, crisp crust. Thus, there is a continuing need for a microwavable package that provides the desired degree of heating, browning, and crisping of the crust or dough of a food item.

### SUMMARY

The present invention is directed generally to various blanks, constructs formed from such blanks, and methods of making such blanks and constructs. The various constructs include one or more features that elevate a food-bearing platform from the turntable and/or the interior floor of the microwave oven. By elevating the food item in this manner, more heat is retained by and/or directed

to the food item, rather than being lost to the turntable or the floor of the microwave oven. As a result, the microwave heating efficiency is improved significantly. The various constructs also may include one or more microwave energy interactive elements that further enhance the heating, browning, and/or crisping of a food item in a microwave oven.

In one aspect, the invention encompasses a blank for a construct, where the blank comprises a main panel and a pair of opposed leg portions extending from the main panel along respective first fold lines. Each first fold line is interrupted by a receiving slot. Each leg portion terminates with a locking feature dimensioned to be received within the respective receiving slot. In one variation of this aspect, each leg portion comprises a plurality of panels joined along fold lines. For example, each leg portion may comprise a first panel joined to the main panel along the first fold line, a second panel joined to the first panel along a second fold line, and a third panel joined to the second panel along a third fold line, with the locking feature extending from the third panel. Various locking features are contemplated hereby. For example, the locking feature may be a tab that is somewhat arrow shaped. A microwave energy interactive element may overlie and/or be joined to at least a portion of the main panel.

Various constructs may be formed from the blank by folding each leg portion along the respective first fold line and inserting each locking feature into the respective receiving slot to form a pair of legs. In one example, the construct includes a platform for receiving a food item thereon, the platform being defined at least partially by the main panel, a pair of legs formed from the folded leg portions, and a microwave energy interactive element overlying and at least partially joined to the platform.

In another aspect, the invention encompasses a blank for a construct, where the blank comprises a pair of opposed leg portions joined to a main panel. Each leg portion includes a first panel joined to the main panel along a

first fold line, a second panel joined to the first panel along a second fold line, and a third panel joined to the second panel along a third fold line. In one variation, the blank also includes a fourth panel joined to the main panel along a fourth fold line. If desired, a microwave energy interactive element may overlie at least a portion of the main panel. A construct generally may be formed from the blank by folding the opposed leg portions toward a first side of the main panel along each respective first fold line, and folding the second panel and the third panel of each leg portion along respective fold lines to form a pair of legs. Various constructs may be formed from the blank.

In one variation of this aspect, the blank further comprises a pair of substantially opposed handle panels extending from the main panel along respective fold lines, where each fold line is interrupted by a cut line. In this variation, a construct may be formed from the blank by folding the opposed leg portions toward a first side of the main panel along each respective first fold line, folding the second panel and the third panel of each leg portion along respective fold lines to form a pair of legs, and folding the opposed handle panels toward a second side of the main panel to form a pair of substantially opposed handles.

In still another aspect, the invention encompasses a blank for a construct, where the blank comprises a pair of substantially opposed leg portions joined to a main panel along respective fold lines. The main panel includes a plurality of apertures extending therethrough. Each leg portion includes a central panel having a length substantially equal to that of the respective fold line. Each leg portion also includes a first end panel and a second end panel hingedly joined to opposed ends of the central panel. The first end panel and the second end panel each include a locking feature proximate to the main panel. At least one of the locking features is dimensioned to be received within at least one of the plurality of apertures. Each locking feature may comprise a substantially rectangular protrusion

extending from an interior edge of each of the first end panels and second end panels or may have any other suitable shape. If desired, a microwave energy interactive element may overlie at least a portion of the main panel.

In one variation of this aspect, the first end panel and the second end panel are joined hingedly to opposed ends of the central panel along respective end panel fold lines, and the plurality of apertures includes at least one aperture substantially aligned with and between the respective first and second end panel fold lines of the opposed leg portions. In another variation of this aspect, the first end panel and the second end panel are joined hingedly to opposed ends of the central panel along respective end panel fold lines, and the plurality of apertures includes at least one aperture offset from the respective first end panel fold lines of the opposed leg portions.

In yet another aspect, the invention encompasses a blank for a construct, where the blank comprises a first leg portion and a second leg portion, each extending from a main panel along a respective fold line. The first leg portion and the second leg portion each include a central panel having a length substantially equal to that of the respective fold line. A first end panel and a second end panel is joined hingedly to opposed ends of the central panel. The first end panel and the second panel each include a locking feature comprising a notch. The notches in the first leg portion extend to an interior edge of the first leg portion proximate the main panel and the notches in the second leg portion extend to an exterior edge of the second leg portion distal the main panel. The notches in the first end panel of each of the first leg portion and the second leg portion are substantially aligned and the notches in the second end panel of each of the first leg portion and the second leg portion are substantially aligned. The notches may have any suitable shape, and in one example, at least one of the notches may comprise a substantially triangular slit. A microwave energy interactive element may overlie at least a portion of the main panel.

A construct may be formed from the blank by folding the first leg portion and the second leg portion toward a surface opposed to a food-contacting surface of the main panel, such that each of the first leg portion and the second leg portion are substantially perpendicular to the main panel, folding the first end panel and the second end panel of each of the first leg portion and the second leg portion inwardly toward one another, such that each of the first leg panels and the second leg panels extend obliquely from the respective center panel, interlocking the notches in the first end panel of the first leg portion and the second leg portion, and interlocking the notches in the second end panel of each of the first leg portion and the second leg portion.

In one variation of this aspect, the blank may include a pair of substantially opposed handle panels extending from the main panel along respective fold lines, where each handle panel includes an elongate aperture. Each handle panel have a substantially arcuate exterior edge. A construct may be formed from the blank by folding the first leg portion and the second leg portion toward a surface opposed to a food-contacting surface of the main panel, such that each of the first leg portion and the second leg portion are substantially perpendicular to the main panel, folding the first end panel and the second end panel of each of the first leg portion and the second leg portion inwardly toward one another, such that each of the first leg panels and the second leg panels extend obliquely from the respective center panel, interlocking the notches in the first end panel of the first leg portion and the second leg portion, interlocking the notches in the second end panel of each of the first leg portion and the second leg portion, and folding the opposed handle panels toward the food-contacting surface to form a pair of substantially opposed handles.

In another variation of this aspect, the blank further comprises a pair of substantially opposed end panels joined to the main panel along respective fold lines. Each end panel includes a center panel and a pair of substantially

opposed bias cut side panels. The main panel includes a receiving slot adjacent to each of the bias cut side panels. Each receiving slot is dimensioned to receive at least a portion of the adjacent bias cut end panel. A construct may be formed from the blank by folding the first leg portion and the second leg portion toward a surface opposed to a food-contacting surface of the main panel, such that each of the first leg portion and the second leg portion are substantially perpendicular to the main panel, folding the first end panel and the second end panel of each of the first leg portion and the second leg portion toward one another, such that each of the first end panel and the second end panel form acute angles relative to the respective center panel, interlocking the notches in the first end panel of the first leg portion and the second leg portion, interlocking the notches in the second end panel of each of the first leg portion and the second leg portion, folding the end panels toward the surface opposed to the food-contacting surface along their respective fold lines, and inserting at least a portion of each of the bias cut side panels into the respective receiving slot.

In still another aspect, the invention encompasses a blank for a construct, where the blank comprises a first leg portion and a second leg portion joined to a main panel. The first leg portion includes a plurality of panels joined along fold lines and a tab extending from an edge of the first leg portion distal the main panel. The second leg portion includes a plurality of panels joined along fold lines and a receiving slot dimensioned to receive the tab extending from the first leg portion.

In one example, the plurality of panels of the first leg portion include a connection portion extending from the main panel, a first panel joined to the connection portion along a first fold line, and a second panel joined to the first panel along a second fold line. In another example, the plurality of panels of the second leg portion include a connection portion extending from the main panel, a first panel joined to the connection portion along a first fold line, a

second panel joined to the first panel along a second fold line, a third panel joined to the second panel along a third fold line, a fourth panel joined to the third panel along a fourth fold line, and a fifth panel joined to the fourth panel along a fifth fold line. The third fold line may be interrupted by the receiving slot.

A microwave energy interactive element, for example, a susceptor film, may overlie and/or be joined to at least a portion of the main panel. The periphery of the microwave energy interactive element may define a boundary between the connection portion and the main panel.

In yet another aspect, the invention contemplates a tray for supporting a food item at an elevated position. The tray comprises a platform including a first surface for supporting the food item and at least one support element extending from a peripheral edge of the platform. The support element includes a plurality of minor panels joined along fold lines. At least one of the minor panels is disposed at least partially below the platform. In one variation, the tray has a length that extends in a lengthwise direction, the platform has a length that extends in the lengthwise direction, the support element has a length that extends in the lengthwise direction, and the length of the platform is greater than the length of the support element. The tray may include a pair of substantially opposed, substantially upwardly extending handles joined to the platform. If desired, a microwave energy interactive element may overlie at least a portion of the platform.

In one variation, the plurality of minor panels includes a first minor panel extending downwardly from the peripheral edge of the platform and a second minor panel foldably joined to the first minor panel. The second minor panel may form an acute angle with respect to the first minor panel, may form an obtuse angle with respect to the first minor panel, or may form a right angle with respect to the first minor panel.

In another variation, at least a portion of the second minor panel lies beneath the platform. At least some of the minor panels of the support element may define a substantially triangular shape or other polygonal shape in an elevational view of the support element. At least a portion of the second minor panel may extend upwardly through an opening in the platform.

If desired, the support element may include a locking feature extending from at least one of the minor panels. The support element may be locked releasably to the main panel by way of interaction between the locking feature and an opening in the main panel.

In another variation, the support element is a first support element, the tray comprises a second support element a peripheral edge of the platform, the second support element includes a plurality of minor panels joined along fold lines, and at least one of the minor panels of the second support element is disposed at least partially below the platform. The first support element and the second support element may cooperate with one another to maintain the first support element and the second support element in a locked configuration. In one example, the first support element includes a tab, the second support element includes a receiving slot dimensioned to receive the tab, and the tab cooperates with the receiving slot to maintain the first support element and the second support element in a locked configuration. In another example, the first support element and the second support element each include a notch, and the notches cooperate with one another to maintain the first support element and the second support element in a locked configuration.

Other features, aspects, and embodiments will be apparent from the following description and accompanying figures.

## BRIEF DESCRIPTION OF THE DRAWINGS

The description refers to the accompanying drawings, some of which are schematic, in which like reference characters refer to like parts throughout the several views, and in which:

**FIG. 1A** depicts an exemplary blank according to various aspects of the invention;

**FIGS. 1B-1D** depict the blank of **FIG. 1** being formed into an exemplary construct for heating, browning, and/or crisping a food item, according to various aspects of the invention;

**FIGS. 1E and 1F** depict an exemplary construct formed from the blank of **FIG. 1A**, according to various aspects of the invention;

**FIG. 2A** depicts another exemplary blank according to various aspects of the invention;

**FIG. 2B** schematically depicts an elevational view of the blank of **FIG. 2A** formed into an exemplary construct;

**FIG. 2C** schematically depicts an elevational view of the blank of **FIG. 2A** formed into another exemplary construct, according to various aspects of the invention;

**FIG. 2D** schematically depicts an elevational view of the blank of **FIG. 2A** formed into yet another exemplary construct, according to various aspects of the invention;

**FIG. 2E** schematically depicts an elevational view of the blank of **FIG. 2A** formed into still another exemplary construct, according to various aspects of the invention;

**FIG. 3A** depicts yet another exemplary blank according to various aspects of the invention;

**FIG. 3B** depicts a bottom view of an exemplary construct formed from the blank of **FIG. 3A**, according to various aspects of the invention;

**FIG. 3C** depicts a perspective view of the exemplary construct of **FIG. 3B**, in an upright configuration, according to various aspects of the invention;

**FIG. 3D** depicts a perspective view of the exemplary construct of **FIG. 3C**, having handles in a partially upright position, according to various aspects of the invention;

**FIG. 4A** depicts still another exemplary blank according to various aspects of the invention;

**FIG. 4B** depicts a bottom view of an exemplary construct formed from the blank of **FIG. 4A**, according to various aspects of the invention;

**FIG. 4C** depicts a top view of the construct of **FIG. 4B**, according to various aspects of the invention;

**FIG. 5A** depicts yet another exemplary blank according to various aspects of the invention;

**FIG. 5B** depicts a bottom view of an exemplary construct formed from the blank of **FIG. 5A**, according to various aspects of the invention;

**FIG. 5C** depicts a top view of the construct of **FIG. 5B**, according to various aspects of the invention;

**FIG. 6A** depicts still another exemplary blank according to various aspects of the invention;

**FIG. 6B** depicts a bottom view of an exemplary construct formed from the blank of **FIG. 6A**, according to various aspects of the invention;

**FIG. 6C** depicts a top view of the construct of **FIG. 6B**, according to various aspects of the invention;

**FIG. 7A** depicts yet another exemplary blank according to various aspects of the invention;

**FIG. 7B** depicts a bottom view of an exemplary construct formed from the blank of **FIG. 7A**, according to various aspects of the invention;

**FIG. 7C** depicts a top view of the construct of **FIG. 7B**, according to various aspects of the invention;

**FIG. 8A** depicts still another exemplary blank according to various aspects of the invention;

**FIG. 8B** depicts a bottom view of an exemplary construct formed from the blank of **FIG. 8A**, according to various aspects of the invention;

**FIG. 8C** depicts a schematic representation of a partial side view of the construct of **FIG. 8B**;

**FIG. 8D** depicts a side view of the construct of **FIG. 8B**; and

**FIG. 8E** depicts a top view of the construct of **FIG. 8B** formed from the blank of **FIG. 8A**, according to various aspects of the present invention.

#### DESCRIPTION

The present invention may be illustrated further by referring to the figures. For simplicity, like numerals may be used to describe like features. It will be understood that where a plurality of similar features are depicted, not all of such features necessarily are labeled on each figure. It also will be understood that various components used to form the blanks and constructs of the present invention may be interchanged. Thus, while only certain combinations are illustrated herein, numerous other combinations and configurations are contemplated hereby.

**FIG. 1A** depicts an exemplary blank **100** according to various aspects of the present invention. The blank **100** may be symmetric or nearly symmetric about a transverse center line **CL1**. Therefore, certain elements in the drawing figures may have similar or identical reference numerals to reflect the whole or partial symmetry.

The blank **100** includes a generally obround food-bearing panel or main panel **102** suitable, for example, for heating a French bread pizza or sandwich thereon. However, in this and other aspects of the invention, it will be understood that numerous suitable shapes and configurations may be used to form the main panel. Examples of other shapes encompassed hereby include,

but are not limited to, polygons, circles, ovals, or any other regular or irregular shape. The shape of the main panel may be determined by the shape of the food item, and it should be understood that different packages are contemplated for different food items, for example, sandwiches, pizzas, French fries, soft pretzels, pizza bites, cheese sticks, pastries, doughs, and so forth. The main panel may be sized and shaped to receive one portion or multiple portions of one or more different food items.

As shown in **FIG. 1A**, the main panel **102** includes a plurality of spaced apertures **104**. In this example, the main panel **102** includes three apertures **104** positioned substantially along the transverse axis or centerline **CL1** of the main panel **102**, each aperture **104** being substantially circular in shape. However, it will be understood that the number, shape, spacing, and positioning of the apertures may vary depending on the food item to be heated and the desired degree of browning and crisping, as will be discussed further below.

The blank **100** includes a pair of substantially opposed support element portions or leg portions **106** extending from a peripheral edge of the main panel **102**. Each leg portion **106** includes a plurality of minor panels joined by fold lines. In this example, each leg portion **106** is formed from a first panel **108**, a second panel **110**, and a third panel **112**. The first panel **108** is joined to the main panel **102** along fold line **114**, which is interrupted by an opening, for example, a receiving slot **116** having oblique end portions **118**. The second panel **110** is joined to the first panel **108** along fold line **120**. The third panel **112** is joined to the second panel **110** along fold line **122**. The third panel **112** includes a somewhat trapezoidal or arrow shaped locking feature or tab **124** at least partially defined by a narrowed section or throat **126**. The tab **124** may be narrower in length than the third panel **112**, as indicated by respective lengths **L1** and **L2** (measured at widest point). Likewise, the throat **126** is narrower in dimension than the tab **124** measured at the widest point, as indicated by **L3**.

Numerous materials may be suitable for use in forming the various blanks and constructs of the invention, provided that the materials are resistant to softening, scorching, combusting, or degrading at typical microwave oven heating temperatures, for example, at from about 250°F to about 425°F. The particular materials used may include microwave energy interactive materials and microwave energy transparent or inactive materials.

For example, any of the various blanks or constructs of the present invention may include one or more features that alter the effect of microwave energy during the heating or cooking of the food item. For example, the blank or construct may be formed at least partially from one or more microwave energy interactive elements (hereinafter sometimes referred to as “microwave interactive elements”) that promote browning and/or crisping of a particular area of the food item, shield a particular area of the food item from microwave energy to prevent overcooking thereof, or transmit microwave energy toward or away from a particular area of the food item. Each microwave interactive element comprises one or more microwave energy interactive materials or segments arranged in a particular configuration to absorb microwave energy, transmit microwave energy, reflect microwave energy, or direct microwave energy, as needed or desired for a particular microwave heating construct and food item.

The microwave interactive element may be supported on a microwave inactive or transparent substrate for ease of handling and/or to prevent contact between the microwave interactive material and the food item. As a matter of convenience and not limitation, and although it is understood that a microwave interactive element supported on a microwave transparent substrate includes both microwave interactive and microwave inactive elements or components, such constructs are referred to herein as “microwave interactive webs”.

The microwave energy interactive material may be an electroconductive or semiconductive material, for example, a metal or a metal alloy provided as a

metal foil; a vacuum deposited metal or metal alloy; or a metallic ink, an organic ink, an inorganic ink, a metallic paste, an organic paste, an inorganic paste, or any combination thereof. Examples of metals and metal alloys that may be suitable for use with the present invention include, but are not limited to, aluminum, chromium, copper, inconel alloys (nickel-chromium-molybdenum alloy with niobium), iron, magnesium, nickel, stainless steel, tin, titanium, tungsten, and any combination or alloy thereof.

Alternatively, the microwave energy interactive material may comprise a metal oxide. Examples of metal oxides that may be suitable for use with the present invention include, but are not limited to, oxides of aluminum, iron, and tin, used in conjunction with an electrically conductive material where needed. Another example of a metal oxide that may be suitable for use with the present invention is indium tin oxide (ITO). ITO can be used as a microwave energy interactive material to provide a heating effect, a shielding effect, a browning and/or crisping effect, or a combination thereof. For example, to form a susceptor, ITO may be sputtered onto a clear polymer film. The sputtering process typically occurs at a lower temperature than the evaporative deposition process used for metal deposition. ITO has a more uniform crystal structure and, therefore, is clear at most coating thicknesses. Additionally, ITO can be used for either heating or field management effects. ITO also may have fewer defects than metals, thereby making thick coatings of ITO more suitable for field management than thick coatings of metals, such as aluminum.

Alternatively, the microwave energy interactive material may comprise a suitable electroconductive, semiconductive, or non-conductive artificial dielectric or ferroelectric. Artificial dielectrics comprise conductive, subdivided material in a polymeric or other suitable matrix or binder, and may include flakes of an electroconductive metal, for example, aluminum.

In one example, the microwave interactive element may comprise a thin layer of microwave interactive material, for example, a susceptor, that tends to

absorb microwave energy and generate heat at the interface with a food item in intimate or proximate contact therewith. Such elements often are used to promote browning and/or crisping of the surface of a food item (sometimes referred to as a “browning and/or crisping element”). When supported on a film or other substrate, such an element may be referred to as a “susceptor film” or, simply, “susceptor”. In the example illustrated in **FIG. 1A**, the blank **100** includes a susceptor film **128** substantially overlying and joined to at least a portion of the main panel **102** to form at least a portion of a first surface **130**, which may serve as a food-contacting or food-bearing surface. However, other microwave energy interactive elements, such as those described herein, are contemplated for use with the invention.

For example, the microwave interactive element may comprise a foil having a thickness sufficient to shield one or more selected portions of the food item from microwave energy (sometimes referred to as a “shielding element”). Such shielding elements may be used where the food item is prone to scorching or drying out during heating. The shielding element may be formed from various materials and may have various configurations, depending on the particular application for which the shielding element is used. Typically, the shielding element is formed from a conductive, reflective metal or metal alloy, for example, aluminum, copper, or stainless steel. The shielding element generally may have a thickness of from about 0.000285 inches to about 0.05 inches. In one aspect, the shielding element has a thickness of from about 0.0003 inches to about 0.03 inches. In another aspect, the shielding element has a thickness of from about 0.00035 inches to about 0.020 inches, for example, 0.016 inches.

As still another example, the microwave interactive element may comprise a segmented foil, such as, but not limited to, those described in U.S. Patent Nos. 6,204,492, 6,433,322, 6,552,315, and 6,677,563, each of which is incorporated by reference in its entirety. Although segmented foils are not

continuous, appropriately spaced groupings of such segments often act as a transmitting element to direct microwave energy to specific areas of the food item. Such foils also may be used in combination with browning and/or crisping elements, for example, susceptors.

Any of the numerous microwave interactive elements described herein or contemplated hereby may be substantially continuous, that is, without substantial breaks or interruptions, or may be discontinuous, for example, by including one or more breaks or apertures that transmit microwave energy therethrough. The breaks or apertures may be sized and/or positioned to heat particular areas of the food item selectively. The number, shape, size, and positioning of such breaks or apertures may vary for a particular application depending on type of construct being formed, the food item to be heated therein or thereon, the desired degree of shielding, browning, and/or crisping, whether direct exposure to microwave energy is needed or desired to attain uniform heating of the food item, the need for regulating the change in temperature of the food item through direct heating, whether and to what extent there is a need for venting, and numerous other factors.

It will be understood that the aperture may be a physical aperture or void in the material used to form the construct, or may be a non-physical "aperture". A non-physical aperture may be a portion of the construct that is microwave energy inactive by deactivation or otherwise, or one that is otherwise transparent to microwave energy. Thus, for example, the aperture may be a portion of the construct formed without a microwave energy active material or, alternatively, may be a portion of the construct formed with a microwave energy active material that has been deactivated. While both physical and non-physical apertures allow the food item to be heated directly by the microwave energy, a physical aperture also provides a venting function to allow steam or other vapors to be released from the food item.

As stated above, any of the above elements and numerous others contemplated hereby may be supported on a substrate. The substrate typically comprises an electrical insulator, for example, a polymer film or other polymeric material. As used herein the terms "polymer", "polymer film", and "polymeric material" include, but are not limited to, homopolymers, copolymers, such as for example, block, graft, random, and alternating copolymers, terpolymers, etc. and blends and modifications thereof. Furthermore, unless otherwise specifically limited, the terms "polymer", "polymer film", and "polymeric material" shall include all possible geometrical configurations of the molecule. These configurations include, but are not limited to isotactic, syndiotactic, and random symmetries.

The thickness of the film typically may be from about 35 gauge to about 10 mil. In one aspect, the thickness of the film is from about 40 to about 80 gauge. In another aspect, the thickness of the film is from about 45 to about 50 gauge. In still another aspect, the thickness of the film is about 48 gauge. Examples of polymer films that may be suitable include, but are not limited to, polyolefins, polyesters, polyamides, polyimides, polysulfones, polyether ketones, cellophanes, or any combination thereof. Other non-conducting substrate materials such as paper and paper laminates, metal oxides, silicates, cellulose, or any combination thereof, also may be used.

In one example, the polymer film comprises polyethylene terephthalate (PET). Polyethylene terephthalate films are used in commercially available susceptors, for example, the QWIKWAVE<sup>®</sup> Focus susceptor and the MICRORITE<sup>®</sup> susceptor, both available from Graphic Packaging International (Marietta, Georgia). Examples of polyethylene terephthalate films that may be suitable for use as the substrate include, but are not limited to, MELINEX<sup>®</sup>, commercially available from DuPont Teijan Films (Hopewell, Virginia), SKYROL, commercially available from SKC, Inc. (Covington, Georgia), and

BARRIALOX PET, available from Toray Films (Front Royal, VA), and QU50 High Barrier Coated PET, available from Toray Films (Front Royal, VA).

The polymer film may be selected to impart various properties to the microwave interactive web, for example, printability, heat resistance, or any other property. As one particular example, the polymer film may be selected to provide a water barrier, oxygen barrier, or a combination thereof. Such barrier film layers may be formed from a polymer film having barrier properties or from any other barrier layer or coating as desired. Suitable polymer films may include, but are not limited to, ethylene vinyl alcohol, barrier nylon, polyvinylidene chloride, barrier fluoropolymer, nylon 6, nylon 6,6, coextruded nylon 6/EVOH/nylon 6, silicon oxide coated film, barrier polyethylene terephthalate, or any combination thereof.

One example of a barrier film that may be suitable for use with the present invention is CAPRAN® EMBLEM 1200M nylon 6, commercially available from Honeywell International (Pottsville, Pennsylvania). Another example of a barrier film that may be suitable is CAPRAN® OXYSHIELD OBS monoaxially oriented coextruded nylon 6/ethylene vinyl alcohol (EVOH)/nylon 6, also commercially available from Honeywell International. Yet another example of a barrier film that may be suitable for use with the present invention is DARTEK® N-201 nylon 6,6, commercially available from Enhance Packaging Technologies (Webster, New York). Additional examples include BARRIALOX PET, available from Toray Films (Front Royal, VA) and QU50 High Barrier Coated PET, available from Toray Films (Front Royal, VA), referred to above.

Still other barrier films include silicon oxide coated films, such as those available from Sheldahl Films (Northfield, Minnesota). Thus, in one example, a susceptor may have a structure including a film, for example, polyethylene terephthalate, with a layer of silicon oxide coated onto the film, and ITO or other material deposited over the silicon oxide. If needed or desired, additional

layers or coatings may be provided to shield the individual layers from damage during processing.

The barrier film may have an oxygen transmission rate (OTR) as measured using ASTM D3985 of less than about 20 cc/m<sup>2</sup>/day. In one aspect, the barrier film has an OTR of less than about 10 cc/m<sup>2</sup>/day. In another aspect, the barrier film has an OTR of less than about 1 cc/m<sup>2</sup>/day. In still another aspect, the barrier film has an OTR of less than about 0.5 cc/m<sup>2</sup>/day. In yet another aspect, the barrier film has an OTR of less than about 0.1 cc/m<sup>2</sup>/day.

The barrier film may have a water vapor transmission rate (WVTR) of less than about 100 g/m<sup>2</sup>/day as measured using ASTM F1249. In one aspect, the barrier film has a water vapor transmission rate as measured using ASTM F1249 of less than about 50 g/m<sup>2</sup>/day. In another aspect, the barrier film has a WVTR of less than about 15 g/m<sup>2</sup>/day. In yet another aspect, the barrier film has a WVTR of less than about 1 g/m<sup>2</sup>/day. In still another aspect, the barrier film has a WVTR of less than about 0.1 g/m<sup>2</sup>/day. In a still further aspect, the barrier film has a WVTR of less than about 0.05 g/m<sup>2</sup>/day.

Other non-conducting substrate materials such as metal oxides, silicates, cellulose, or any combination thereof, also may be used in accordance with the present invention.

The microwave energy interactive material may be applied to the substrate in any suitable manner, and in some instances, the microwave energy interactive material is printed on, extruded onto, sputtered onto, evaporated on, or laminated to the substrate. The microwave energy interactive material may be applied to the substrate in any pattern, and using any technique, to achieve the desired heating effect of the food item. For example, the microwave energy interactive material may be provided as a continuous or discontinuous layer or coating including circles, loops, hexagons, islands, squares, rectangles, octagons, and so forth. Examples of various patterns and methods that may be suitable for use with the present invention are provided in U.S. Patent Nos.

6,765,182; 6,717,121; 6,677,563; 6,552,315; 6,455,827; 6,433,322; 6,410,290; 6,251,451; 6,204,492; 6,150,646; 6,114,679; 5,800,724; 5,759,418; 5,672,407; 5,628,921; 5,519,195; 5,420,517; 5,410,135; 5,354,973; 5,340,436; 5,266,386; 5,260,537; 5,221,419; 5,213,902; 5,117,078; 5,039,364; 4,963,420; 4,936,935; 4,890,439; 4,775,771; 4,865,921; and Re. 34,683, each of which is incorporated by reference herein in its entirety. Although particular examples of patterns of microwave energy interactive material are shown and described herein, it should be understood that other patterns of microwave energy interactive material are contemplated by the present invention.

If desired, the microwave interactive element or microwave interactive web may be joined to or overlie a dimensionally stable, microwave energy transparent support (hereinafter referred to as “microwave transparent support”, “microwave inactive support” or “support”) to form at least a portion of the construct.

In one aspect, for example, where a rigid or semi-rigid construct is to be formed, all or a portion of the support may be formed at least partially from a paperboard material, which may be cut into a blank prior to use in the construct. For example, the support may be formed from paperboard having a basis weight of from about 60 to about 330 lbs/ream, for example, from about 80 to about 140 lbs/ream. The paperboard generally may have a thickness of from about 6 to about 30 mils, for example, from about 12 to about 28 mils. In one particular example, the paperboard has a thickness of about 12 mils. Any suitable paperboard may be used, for example, a solid bleached or solid unbleached sulfate board, such as SUS® board, commercially available from Graphic Packaging International.

In another aspect, where a more flexible construct is to be formed, the support may comprise a paper or paper-based material generally having a basis weight of from about 15 to about 60 lbs/ream, for example, from about 20 to

about 40 lbs/ream. In one particular example, the paper has a basis weight of about 25 lbs/ream.

Optionally, one or more portions or sides of the various blanks or other constructs described herein or contemplated hereby may be coated with varnish, clay, or other materials, either alone or in combination. For example, at least the side of the support that will form an exterior surface of a construct erected therefrom may be coated with a clay coating or other base coating. The coating may then be printed over with product advertising, images, price coding, any other information or indicia, or any combination thereof. The blank or construct may then may be overcoated with a varnish to protect any information printed thereon.

Furthermore, the blanks or other constructs may be coated with, for example, a moisture and/or oxygen barrier layer, on either or both sides, such as those described above. Any suitable moisture and/or oxygen barrier material may be used in accordance with the present invention. Examples of materials that may be suitable include, but are not limited to, polyvinylidene chloride, ethylene vinyl alcohol, DuPont DARTEK™ nylon 6,6, and others referred to above.

Alternatively or additionally, any of the blanks or other constructs of the present invention may be coated or laminated with other materials to impart other properties, such as absorbency, repellency, opacity, color, printability, stiffness, or cushioning. For example, absorbent susceptors are described in U.S. Provisional Application No. 60/604,637, filed August 25, 2004, and U.S. Patent Application No. 11/211,854, to Middleton, et al., titled "Absorbent Microwave Interactive Packaging", filed August 25, 2005, both of which are incorporated herein by reference in their entirety.

It will be understood that with some combinations of elements and materials, the microwave interactive element may have a grey or silver color this is visually distinguishable from the substrate or the support. However, in

some instances, it may be desirable to provide a web or construct having a uniform color and/or appearance. Such a web or construct may be more aesthetically pleasing to a consumer, particularly when the consumer is accustomed to packages or containers having certain visual attributes, for example, a solid color, a particular pattern, and so on. Thus, for example, the present invention contemplates using a silver or grey toned adhesive to join the microwave interactive elements to the substrate, using a silver or grey toned substrate to mask the presence of the silver or grey toned microwave interactive element, using a dark toned substrate, for example, a black toned substrate, to conceal the presence of the silver or grey toned microwave interactive element, overprinting the metallized side of the web with a silver or grey toned ink to obscure the color variation, printing the non-metallized side of the web with a silver or grey ink or other concealing color in a suitable pattern or as a solid color layer to mask or conceal the presence of the microwave interactive element, or any other suitable technique or combination thereof.

Turning to **FIGS. 1B-1E**, to form the blank **100** into a construct, for example, a tray **132**, one of the tabs **124** may be brought toward the bottom surface **134** of the main panel **102** and inserted into the respective proximate receiving slot **116**. In doing so, the various panels **108**, **110**, **112** may be folded along fold lines **114**, **120**, **122**, thereby forming a somewhat triangular shaped support element or leg **136** that lies partially beneath and serves to support the food-bearing panel or platform **102** (**FIG. 1C**). This process may be repeated (not shown) for the other leg portion **106** to form a second support element or leg **136** secured within the respective receiving slot **116** (**FIG. 1D**). As shown in **FIGS. 1E** and **1F**, in which the tray **132** has been inverted and placed in an upright configuration, the tabs **124** extend through respective receiving slots **116** to form a pair of upwardly extending handles **138** that may be used to grasp the tray **132**.

Alternatively, to assemble the tray **132**, the first panel **108** may be folded along fold line **114** in a direction away from the food-contacting surface **130** so that the first panel **108** is somewhat perpendicular to the platform **102**. A first leg **136** then may be formed by folding the second panel **110** past the first panel **108** along fold lines **120** and **122** such that the second panel **110** is substantially parallel with the platform **102**. At this point, the tab **124** is superposed with the platform **102**. Next, the third panel **112** may be folded toward the platform **102** and the tab **124** is inserted through the receiving slot **116**, thereby forming somewhat triangular shaped support elements or legs **136** that support the food-bearing panel or platform **102**. In particular, each leg **136** respectively includes somewhat vertical and oblique supporting panels **108** and **112** and a horizontal supporting panel **110**. The tabs **124** extend through receiving slots **116** to form handles **138** that may be used to grasp the tray **132**.

In this and other aspects of the invention, it will be understood that while various methods of forming a tray are provided herein, other methods are contemplated hereby. The method used may depend on various factors, including the shape of the platform, and so forth. Additionally, in the example described in detail herein, the legs are somewhat triangular in shape. However, it will be understood that the leg portions and each of the various components thereof may have any suitable shape and dimensions depending on the size and weight of the food item, the resulting size of the platform **102**, the desired degree of stability in the construct formed from the blank **100**, and numerous other factors. For example, the legs may have a somewhat square shape by including an additional panel. A still additional panel may result in legs having a pentagonal shape. Other shapes are contemplated hereby.

Viewing **FIGS. 1E** and **1F**, to use the tray **132**, a food item (not shown) is placed on the food-bearing surface **130** of the platform **102** and placed in a microwave oven (not shown). The support elements or legs **136** support the platform **102** and maintain the food item at an elevated position in the

microwave oven (not shown). The apertures **104** provide venting of steam that is generated during heating, thereby improving browning and/or crisping of the food item. Additionally, the air between the platform **102** and the floor of the microwave oven provides an insulating effect, thereby decreasing the amount of heat loss from the microwave energy interactive material to the floor of the microwave oven, particularly where a susceptor **128** is used.

**FIG. 2A** illustrates another exemplary blank **200** that may be used in accordance with various aspects of the invention. The blank **200** may be symmetric or nearly symmetric about a transverse center line **CL2**. Therefore, certain elements in the drawing figures may have similar or identical reference numerals to reflect the whole or partial symmetry.

The blank **200** includes a generally obround food-bearing panel or main panel **202** having an elongate central portion and rounded end portions suitable, for example, for heating a French bread pizza or open-faced sandwich thereon. However, it will be understood that in this and other aspects of the invention described herein or contemplated hereby, numerous suitable shapes and configurations may be used in accordance with the invention.

Still viewing **FIG. 2A**, the main panel **202** also includes a plurality of spaced apertures **204**. In this example, the main panel **202** includes three apertures **204** positioned substantially along a transverse axis or centerline **CL2** of the main panel **202**, each aperture **204** being substantially circular in shape and extending through the thickness of the main panel **202**. However, it will be understood that in this and other aspects of the present invention, the number, shape, spacing, and positioning of the apertures may vary depending on the food item to be heated and the desired degree of browning and crisping.

The blank **200** includes a pair of substantially opposed support element portions or leg portions **206** extending from the main panel **202**. Each leg portion **206** includes a plurality of minor panels joined by fold lines. In this example, each leg portion **206** is formed from a first panel **208**, a second panel

**210**, a third panel **212**, and a fourth panel **214**. The first panel **208** is joined to the main panel **202** along fold line **216**. The second panel **210** is joined to the first panel **208** along fold line **218**. The third panel **212** is joined to the second panel **210** along fold line **220**. The fourth panel **214** is joined to the third panel **212** along fold line **222**. If desired, a microwave energy interactive element, for example, a susceptor **224**, may overlie and be joined to at least a portion of the main panel **202**, thereby at least partially defining a food contacting surface **226**.

To assemble the blank **200** into a construct, for example, a tray **228** (shown in schematic elevational view in **FIGS. 2B-2E**), the various minor panels **208**, **210**, **212**, **214** of each leg portion **206** generally may be folded along respective fold lines **216**, **218**, **220**, **222**, such that the various panels **208**, **210**, **212**, **214** cooperate to form a leg **230** having one or more vertical and/or horizontal support components or leg components. The legs **230** may have various shapes, as shown in **FIGS. 2B-2E**. For example the leg **230** of **FIG. 2B** is somewhat triangular in shape, with the fourth panel **214** serving as a somewhat vertical or oblique support for the platform **202**. In **FIG. 2C**, the leg **230** is somewhat triangular in shape, with the fourth panel **214** serving as a somewhat horizontal support panel substantially parallel to the platform **202**. In **FIG. 2D**, the leg **230** is somewhat square in shape, with the fourth panel **214** serving as a somewhat horizontal support panel directed toward the other panels that form the leg **230**. In **FIG. 2E**, the leg **230** is somewhat square in shape, with the fourth panel **214** serving as a somewhat horizontal support panel substantially parallel to the platform **202**. While various leg configurations are shown herein, it will be understood that numerous other leg configurations are contemplated hereby. Thus, for example, fewer or more panels may be provided to make a triangular shape, square shape, pentagonal shape, hexagonal shape, and so forth.

In use, a food item (not shown) is placed on the food bearing surface **226** of the tray **228** and placed in a microwave oven (not shown). Legs **230** support the platform **202** and maintain the food item at an elevated position in the microwave oven. In this and other aspects of the present invention, the air between the platform **202** and the floor of the microwave oven provides an insulating effect, which decreases the heat loss to the microwave oven. Additionally, the apertures **204** tend to provide venting of steam that is generated during heating, thereby improving browning and/or crisping of the food item.

**FIG. 3A** depicts another exemplary blank **300** in accordance with various aspects of the invention. The blank **300** includes some features that are similar to those described in connection with the blank **200** of **FIG. 2A** and, for purposes of simplicity and not limitation, the description of such features is not repeated in connection herewith.

In this example, the blank **300** includes a main panel **302** having a pair of handle panels **304** extending therefrom along a somewhat arcuate score line, slit, or cut line **306**. Other cut line shapes are contemplated hereby. Fold lines **308** extend between the score line or cut line **306** and the peripheral edge **310** of the blank **300**. If desired, a microwave energy interactive element **312**, for example, a susceptor, shield, or energy directing element, may overlie and be joined to at least a portion of the main panel **302**, and optionally may define at least a portion a food contacting surface **314**. The microwave energy interactive element also may overlie and be joined at least partially to the handle panels **304**, as shown in **FIG. 3A**.

Turning to **FIG. 3B**, the blank **300** may be formed into a tray **316** in a manner similar to that described in connection with the blank **200** of **FIG. 2A**. When inverted and positioned in an upright configuration as shown in **FIG. 3C**, the tray **316** is ready to be used. If desired, handle panels **304** may be folded toward the main panel **302** along score line or cut line **306** and fold lines

**308** to create upwardly extending handles for grasping the tray **316**, as shown in **FIG. 3D**. In this manner, contact with the food item (not shown) and/or platform **302**, either or both of which may be hot, may be avoided substantially. Additionally, handles **304** may serve to secure the food item (not shown) on the platform **302**.

**FIG. 4A** depicts another exemplary blank **400** according to various aspects of the present invention. The blank **400** may be symmetric or nearly symmetric about a transverse center line **CL3**. Therefore, certain elements in the drawing figures may have similar or identical reference numerals to reflect the whole or partial symmetry.

The blank **400** includes a substantially oval main panel **402**. However, in this and other aspects of the present invention, it will be understood that any shaped main panel may be used as desired. Substantially opposed leg portions **404** extend from the main panel **402** along fold lines **406**. Each leg portion **404** comprises a plurality of minor panels including a first panel, for example, a central support panel **408**, and a pair of hinged end panels **410**. The central support panel **408** has a length that corresponds substantially to the length **L4** of fold line **406**. End panels **410** are joined to the central support panel **408** along end panel fold lines **412**. A locking feature, in this example, a rectangular projection or tab **414**, extends from an interior edge of each end panel **410** toward the main panel **402**. If desired, the central support panel **408** may include one or more cuts or indentations, for example, somewhat C-shaped cut lines **416** to facilitate folding along fold lines **406**.

Still viewing **FIG. 4A**, a plurality of apertures **418** extend through the thickness of the main panel **402**. The apertures **418** are dimensioned and positioned to receive a locking feature **414** extending from each end panel **410**. In this example, the apertures **418** are arranged in two rows, each having three apertures, spaced along opposed sides of centerline **CL3**. However, other configurations are contemplated hereby.

Now viewing **FIGS. 4A-4C**, to form the blank **400** into a tray **420**, leg portions **404** may be folded toward a bottom surface **422** of the main panel **402** such that the leg portions **404** are substantially perpendicular to the main panel **402**. The end panels **410** of each leg portion **404** may be folded toward each other along fold lines **412** such that the end panels **410** substantially form right angles with respect to the central support panel **408**. Each locking feature **414** then may be aligned with and inserted into the appropriate corresponding or adjacent aperture **418**. The locking feature **414** extends upwardly into the plane of the main panel **402**, and may extend beyond the plane of the main panel **402**, and locks into position (**FIG. 4B**) to form a pair of somewhat square C-shaped legs **424**.

As shown in **FIG. 4B**, when the end panels **410** of this example are secured within the apertures **418**, the end panels **410** are substantially perpendicular to the central support panel **408**. In use, this leg configuration provides additional support to the platform along centerline **CL3**, as compared with a leg configuration in which no central support is provided.

**FIG. 4C** depicts the construct or tray **420** in an upright configuration. If desired, a microwave energy interactive element, for example, a susceptor **426**, may overlie the platform **402** and form a portion of the food bearing surface **428**. The resulting tray **420** may be used as described above with respect to the various other constructs of the invention.

**FIG. 5A** depicts yet another exemplary blank **500** according to various aspects of the present invention. The blank **500** includes features similar to that of blank **400** described in connection with **FIG. 4A** and, for purposes of simplicity and not limitation, such features are not described in connection herewith. Further, the blank **500** may be symmetric or nearly symmetric about a transverse center line **CL4**. Therefore, certain elements in the drawing figures may have similar or identical reference numerals to reflect the whole or partial symmetry.

In this example, the main panel **502** includes a plurality of apertures **504** arranged in an alternating, sinusoidal wavelike configuration extending between opposed leg portions **506**. A microwave energy interactive element, in this example, a susceptor **508**, overlies the main panel **502** to define at least a portion of a food-contacting surface **510**.

Turning to **FIG. 5B**, a construct, for example, a tray **512**, may be formed from the blank **500** of **FIG. 5A** in a manner similar to that described in connection with **FIGS. 4A-4C**. In this example, however, the end panels **514** extend obliquely toward the centerline **CL4** and lock within apertures **504** to form opposed, offset legs **516** that support to the platform **502**. As is evident from **FIG. 5B**, some of the end panels **514** form an acute angle with respect to the central panel **518**, and some of the end panels **514** form an obtuse angle with respect to the central panel **518**. **FIG. 5C** depicts the tray **512** in an upright configuration with the locking features **520** secured within the apertures **504**. The tray **512** may be used as described above with respect to the various other constructs of the invention.

**FIG. 6A** depicts yet another exemplary blank **600** according to various aspects of the present invention. In this example, the blank **600** includes a somewhat rectangular main panel **602** having a first dimension or length **L5** and a second dimension or width **W**. The main panel **602** includes a plurality of apertures **604** arranged proximate to centerline **CL5**, although other aperture configurations may be used.

Opposed leg portions **606** extend along the length of the main panel **602** along respective fold lines **608**. Each leg portion **606** includes a central support panel **610** and a pair of end panels **612** joined to the central support panel **610** along end panel fold lines **614**. The length of the central support panel **610** corresponds substantially to the length **L6** of fold lines **608**. A locking tab **616** or other feature defined by a somewhat v-shaped or triangular, notch or slit **618** terminates each end panel **612**. If desired, the central support panel **610** may

include one or more cut lines **620** or indentations to facilitate folding along fold line **608**.

Handle panels **622** extend from the main panel **602** along fold lines **624**. Each handle panel **622** includes an elongate aperture **626** extending between the leg portions **606**. A microwave energy interactive element, in this example, a substantially oval shaped susceptor **628**, overlies at least a portion of the main panel **602** to define at least a portion of a food-contacting or food-bearing surface **630**.

Now viewing **FIGS. 6A-6C**, to form a tray **632** from the blank **600**, leg portions **606** may be folded toward a bottom surface **634** of the main panel **602** along fold lines **608** so that the central support panel **610** is substantially perpendicular to the main panel **602**. Each pair of opposed end panels **612** then is brought together by folding along fold lines **614**, and locked by interconnecting each pair of opposed notches **618** to form opposed, interconnected legs **636**, as shown in **FIG. 6B**. As with various other aspects of this invention, this configuration provides strength to the platform **602** for supporting a food item (not shown) thereon. As shown in **FIG. 6C**, the handle panels **622** may be folded toward the food-bearing surface **630** of the platform **602** along fold lines **624** to provide a means of handling the tray **632**.

**FIG. 7A** depicts still another exemplary blank **700** according to various aspects of the present invention. The blank **700** includes some features similar to that of blank **600** described in connection with **FIG. 6A** and, for purposes of simplicity, such features are not described in detail in connection herewith.

In the example shown in **FIG. 7A**, the blank **700** includes a main panel **702** having end panels **704** defined partially by cut lines **706**, oblique cut lines **708**, and fold lines **710**. Each end panel **704** includes a center panel **712** and a pair of bias cut end panels **714** joined to the center panel **712** along respective fold lines **716**. The main panel **702** includes a plurality of slits **718** capable of

receiving the bias cut side panels **714** adjacent to and aligned therewith. If desired, the blank **700** may include one or more cuts or indentations **720** to facilitate folding along fold lines **710**. A somewhat obround microwave energy interactive element, for example, a susceptor **722**, may overlie at least a portion of the main panel **702** to form at least a portion of a food-bearing surface **724**.

To form the blank **700** into a tray **726**, opposed leg portions **728** may be folded and interlocked as described in connection with the blank **600** of **FIG. 6B** to form legs **730**. End panels **704** may be folded toward the bottom surface **732** of the main panel **702**. Side panels **714** may be folded along lines **716** toward the center panel **712** of the end panels **704** and inserted into the corresponding adjacent slits **718** to secure each end panel **704** into a locked position, thereby forming legs **732**, as shown in **FIG. 7C**. The tray **726** may be used similarly to other constructs described herein.

**FIG. 8A** depicts still another exemplary blank **800** according to various aspects of the invention. The blank **800** may be symmetric or nearly symmetric about a transverse center line **CL6**. Therefore, certain elements in the drawing figures may have similar or identical reference numerals to reflect the whole or partial symmetry.

The blank **800** includes a food-bearing panel or main panel **802**. In this example, the main panel **802** is somewhat circular in shape, suitable, for example, for heating a pizza thereon. However, numerous other shapes and configurations may be used. The main panel **802** includes a plurality of substantially circular spaced apertures **804** positioned substantially along the transverse axis or centerline **CL6**. In this example, the main panel **802** includes two apertures **804** extending through the thickness of the blank **800**. Other aperture configurations are contemplated hereby.

The blank **800** also includes a pair of leg portions **806**, **808** extending from the main panel **802**. Leg portions **806**, **808** each include a plurality of minor panels joined by fold lines. In particular, a first leg portion **806** includes

a connection portion **810** extending from the main panel **802** along a boundary **812**, a first panel **814** joined to the connection portion **810** along a fold line **816**, a second panel **818** joined to the first panel **814** along a fold line **820**, and a tab **822** extending from the second panel **818**. The connection portion **810** and the first panel **814** are somewhat tapered along their respective edges **824**, **826** when viewed from the main panel **802** toward the tab **822**. The second panel **818** is somewhat rectangular in shape with substantially parallel edges **828**. However, it will be understood that other joining panel, leg panel, and main panel configurations may be used as needed to support adequately the platform of the package formed from the blank.

The tab **822** may have any suitable shape and configuration, and may be sized generally to be inserted within a receiving slot or other receiving feature or opening (discussed below). In this example, the tab **822** is positioned substantially centered along the centerline **CL6** of the blank **800**, and is substantially rectangular in shape with cambered corners **830** to resemble an arrow. If desired, juts **832** may be provided to secure the tab **822** when inserted into the receiving slot or other receiving feature (discussed below). While a tab is shown herein, it will be understood that other locking features may be used in accordance with the present invention. Thus, for example, a plurality of tabs or other locking features may be used, and such features may be aligned in any manner with any suitable spacing as needed or desired for a particular application.

Still viewing **FIG. 8A**, a second leg portion **808** includes a connection portion **834** extending from the main panel **802** along the boundary **812**, a first panel **836** joined to the connection portion **834** along a fold line **838**, a second panel **840** joined to the first panel **836** along a fold line **842**, and a hinge portion **844** joined to the second panel **840** along a fold line **846**. The fold line **846** is interrupted by an opening, for example, receiving slot **848** (referred to above). The hinge portion **844** includes a first hinge panel **850** joined to the

main panel **840** along fold line **846**, a second hinge panel **852** joined to the first hinge panel **850** along fold line **854**, and a third hinge panel **856** joined to the second panel **850** along a fold line **858**.

In this example, the connection portion **834** and the first panel **836** are somewhat tapered along their respective edges **860**, **862** when viewed from the second panel **802** toward the hinge portion **844**. Further, in this example, the second panel **840** is somewhat rectangular in shape with substantially parallel edges **864**. The first hinge panel **850** is somewhat tapered along edges **866** from the second panel **840** to the second hinge panel **852**, the second hinge panel **852** is somewhat reverse tapered along edges **868**, and the third hinge panel **856** is somewhat rectangular in shape with substantially parallel edges **870**. However, it will be understood that other panel configurations may be used as needed to support the platform of the package formed from the blank. If desired, a microwave energy interactive element, for example, a susceptor **872**, may overlie all or a portion of the main panel **802** to form at least a portion of a food-contacting surface **874**. In this example, the susceptor **872** defines the boundary **812** between the main panel **802** and the connection portions **810** and **834**. However, other arrangements are contemplated hereby.

As shown in **FIGS. 8B-8E**, to form the blank **800** into a construct, for example, a tray **876**, the first leg portion **806** may be folded along fold lines **816** and **820**. Likewise, second leg portion **808** may be folded along fold lines **838**, **842**, **846**, **854**, and **858**. Leg portions **806** and **808** then may be brought toward each other such that the tab **822** is aligned with and can be inserted into the receiving slot **848**, as shown in **FIG. 8B**. In doing so, the first hinge panel **850** and the second hinge panel **852** form a somewhat arcuate “V” or “U” configuration, with the third hinge panel **856** extending therefrom, as shown schematically in **FIG. 8C**. In this configuration, the third hinge panel **856** is superposed with at least a portion of the second panel **818** of the first leg portion **806**. As shown in **FIG. 8D**, the folded and secured first leg portion **806**

and second leg portion **808** form legs **878** that support the platform **802**. In this example, a void or airspace **880** lies between the bottom surface **882** of the platform **802** and each of the main panels **818** and **840**.

In use, a food item (not shown) is placed on the food-bearing surface **874** (FIG. 8E) of the platform **802**, and the tray **876** with the food item thereon is placed in a microwave oven (not shown). The various panels of the first leg portion **806** and the second leg portion **808** cooperate to form legs **878** that support the platform **802** and maintain the food item at an elevated position in the microwave oven. In this and other aspects of the present invention, the air between the platform and the floor of the microwave oven provides an insulating effect, which decreases the heat loss to the microwave oven. Additionally, the apertures **804** may provide venting of steam that is generated during heating, thereby improving browning and crisping of the food item.

While various leg configurations are shown herein, it will be understood that numerous other leg configurations are contemplated by the present invention. For example, if no insulation is desired, the void or airspace can be minimized or eliminated. Likewise, where venting apertures are not needed or desired, such features can be eliminated.

It will be understood that in each of the various blanks and trays described herein and contemplated hereby, a "fold line" can be any substantially linear, although not necessarily straight, form of weakening that facilitates folding therealong. More specifically, but not for the purpose of narrowing the scope of the present invention, a fold line may be a score line, such as lines formed with a blunt scoring knife, or the like, which creates a crushed portion in the material along the desired line of weakness; a cut that extends partially into a material along the desired line of weakness, and/or a series of cuts that extend partially into and/or completely through the material along the desired line of weakness; or any combination of these features.

While various examples of constructs are provided herein, it will be understood that any configuration of components may be used as needed or desired. The construct may be flexible, semi-rigid, rigid, or may include a variety of components having different degrees of flexibility. Additionally, it should be understood that the present invention contemplates constructs for single-serving portions and for multiple-serving portions. It also should be understood that various components used to form the constructs of the present invention may be interchanged. Thus, while only certain combinations are illustrated herein, numerous other combinations and configurations are contemplated hereby.

Although certain embodiments of this invention have been described with a certain degree of particularity, those skilled in the art could make numerous alterations to the disclosed embodiments without departing from the spirit or scope of this invention. All directional references (e.g., upper, lower, upward, downward, left, right, leftward, rightward, top, bottom, above, below, vertical, horizontal, clockwise, and counterclockwise) are used only for identification purposes to aid the reader's understanding of the various embodiments of the present invention, and do not create limitations, particularly as to the position, orientation, or use of the invention unless specifically set forth in the claims. Joinder references (e.g., joined, attached, coupled, connected, and the like) are to be construed broadly and may include intermediate members between a connection of elements and relative movement between elements. As such, joinder references do not necessarily imply that two elements are connected directly and in fixed relation to each other.

It will be recognized by those skilled in the art, that various elements discussed with reference to the various embodiments may be interchanged to create entirely new embodiments coming within the scope of the present invention. It is intended that all matter contained in the above description or

shown in the accompanying drawings shall be interpreted as illustrative only and not limiting. Changes in detail or structure may be made without departing from the spirit of the invention. The detailed description set forth herein is not intended nor is to be construed to limit the present invention or otherwise to exclude any such other embodiments, adaptations, variations, modifications, and equivalent arrangements of the present invention.

Accordingly, it will be readily understood by those persons skilled in the art that, in view of the above detailed description of the invention, the present invention is susceptible of broad utility and application. Many adaptations of the present invention other than those herein described, as well as many variations, modifications, and equivalent arrangements will be apparent from or reasonably suggested by the present invention and the above detailed description thereof, without departing from the substance or scope of the present invention.

While the present invention is described herein in detail in relation to specific aspects, it is to be understood that this detailed description is only illustrative and exemplary of the present invention and is made merely for purposes of providing a full and enabling disclosure of the present invention and to provide the best mode contemplated by the inventor or inventors of carrying out the invention. The detailed description set forth herein is not intended nor is to be construed to limit the present invention or otherwise to exclude any such other embodiments, adaptations, variations, modifications, and equivalent arrangements of the present invention.

What is claimed is:

1. A blank for a construct, comprising:  
a main panel; and  
a pair of opposed leg portions extending from the main panel along respective first fold lines, wherein  
each first fold line is interrupted by a receiving slot, and  
each leg portion terminates with a locking feature dimensioned to be received within the respective receiving slot.
2. The blank of claim 1, wherein each leg portion comprises a plurality of panels joined along fold lines.
3. The blank of claim 1, wherein each leg portion comprises a first panel joined to the main panel along the first fold line, a second panel joined to the first panel along a second fold line, and a third panel joined to the second panel along a third fold line, wherein the locking feature extends from the third panel.
4. The blank of claim 1, wherein each locking feature comprises a tab that resembles an arrow.
5. The blank of claim 1, further comprising a microwave energy interactive element overlying and at least partially joined to the main panel.
6. A method of forming a construct from the blank of claim 1, comprising:  
folding each leg portion along the respective first fold line; and  
inserting each locking feature into the respective receiving slot to form a pair of legs.

7. A construct formed from the blank of claim 1, the construct including:
  - a platform for receiving a food item thereon, the platform being defined at least partially by the main panel;
  - a pair of legs formed from the leg portions; and
  - a microwave energy interactive element overlying and joined to at least a portion of the platform.
  
8. A blank for a construct, comprising:
  - a main panel; and
  - a pair of opposed leg portions joined to the main panel, each leg portion including
    - a first panel joined to the main panel along a first fold line,
    - a second panel joined to the first panel along a second fold line,
  - and
  - a third panel joined to the second panel along a third fold line.
  
9. The blank of claim 8, further comprising a fourth panel joined to the main panel along a fourth fold line.
  
10. The blank of claim 8, further comprising a microwave energy interactive element overlying at least a portion of the main panel.
  
11. A method of forming a construct from the blank of claim 8, comprising:
  - folding the opposed leg portions toward a first side of the main panel along each respective first fold line; and
  - folding the second panel and the third panel of each leg portion along the respective second fold line and third fold line to form a pair of legs.

12. The blank of claim 8, further comprising a pair of substantially opposed handle panels extending from the main panel along respective fold lines, wherein each fold line is interrupted by a cut line.

13. A method of forming a construct from the blank of claim 12, comprising:

    folding the opposed leg portions toward a first side of the main panel along each respective first fold line;

    folding the second panel and the third panel of each leg portion along the respective second fold line and third fold line to form a pair of legs; and

    folding the opposed handle panels toward a second side of the main panel to form a pair of substantially opposed handles.

14. A blank for a construct, comprising:

    a main panel including a plurality of apertures extending therethrough;  
and

    a pair of substantially opposed leg portions joined to the main panel along respective fold lines, each leg portion including

        a central panel having a length substantially equal to that of the respective fold line, and

        a first end panel and a second end panel hingedly joined to opposed ends of the central panel, the first end panel and the second end panel each including a locking feature proximate to the main panel, wherein at least one of the locking features is dimensioned to be received within at least one of the plurality of apertures.

15. The blank of claim 14, wherein at least one of the locking features comprises a substantially rectangular protrusion extending from an interior

edge of the first end panel or second end panel of at least one of the opposed leg portions.

16. The blank of claim 14, further comprising a microwave energy interactive element overlying at least a portion of the main panel.

17. The blank of claim 14, wherein  
the first end panel and the second end panel are joined hingedly to opposed ends of the central panel along respective end panel fold lines, and  
the plurality of apertures includes at least one aperture substantially aligned with and between the respective first and second end panel fold lines of the opposed leg portions.

18. The blank of claim 14, wherein  
the first end panel and the second end panel are joined hingedly to opposed ends of the central panel along respective end panel fold lines, and  
the plurality of apertures includes at least one aperture offset from the respective first end panel fold lines of the opposed leg portions.

19. A blank for a construct comprising:  
a main panel; and  
a first leg portion and a second leg portion, each extending from the main panel along a respective fold line, the first leg portion and the second leg portion each including  
a central panel having a length substantially equal to that of the respective fold line, and  
a first end panel and a second end panel hingedly joined to opposed ends of the central panel, the first end panel and the second panel each including a locking feature comprising a notch, wherein

the notches in the first leg portion extend to an interior edge of the first leg portion proximate the main panel,

the notches in the second leg portion extend to an exterior edge of the second leg portion distal the main panel,

the notches in the first end panel of each of the first leg portion and the second leg portion are substantially aligned, and

the notches in the second end panel of each of the first leg portion and the second leg portion are substantially aligned.

20. The blank of claim 19, wherein at least one of the notches comprises a substantially triangular slit.

21. The blank of claim 19, further comprising a microwave energy interactive element overlying at least a portion of the main panel.

22. A method of forming a construct from the blank of claim 19, comprising:

folding the first leg portion and the second leg portion toward a surface opposed to a food-contacting surface of the main panel, such that each of the first leg portion and the second leg portion are substantially perpendicular to the main panel;

folding the first end panel and the second end panel of each of the first leg portion and the second leg portion inwardly toward one another, such that each of the first leg panels and the second leg panels extend obliquely from the respective center panel;

interlocking the notches in the first end panel of the first leg portion and the second leg portion; and

interlocking the notches in the second end panel of each of the first leg portion and the second leg portion.

23. The blank of claim 19, further comprising a pair of substantially opposed handle panels extending from the main panel along respective fold lines, each handle panel including an elongate aperture.

24. The blank of claim 23, wherein each handle panel has a substantially arcuate exterior edge.

25. A method of forming a construct from the blank of claim 23, comprising:

    folding the first leg portion and the second leg portion toward a surface opposed to a food-contacting surface of the main panel, such that each of the first leg portion and the second leg portion are substantially perpendicular to the main panel;

    folding the first end panel and the second end panel of each of the first leg portion and the second leg portion inwardly toward one another, such that each of the first leg panels and the second leg panels extend obliquely from the respective center panel;

    interlocking the notches in the first end panel of the first leg portion and the second leg portion;

    interlocking the notches in the second end panel of each of the first leg portion and the second leg portion; and

    folding the opposed handle panels toward the food-contacting surface to form a pair of substantially opposed handles.

26. The blank of claim 19, further comprising a pair of substantially opposed end panels joined to the main panel along respective fold lines, wherein

each end panel includes a center panel and a pair of substantially opposed bias cut side panels,

the main panel includes a receiving slot adjacent to each of the bias cut side panels, and

each receiving slot is dimensioned to receive at least a portion of the adjacent bias cut end panel.

27. A method of forming a construct from the blank of claim 26, comprising:

folding the first leg portion and the second leg portion toward a surface opposed to a food-contacting surface of the main panel, such that each of the first leg portion and the second leg portion are substantially perpendicular to the main panel;

folding the first end panel and the second end panel of each of the first leg portion and the second leg portion toward one another, such that each of the first end panel and the second end panel form acute angles relative to the respective center panel;

interlocking the notches in the first end panel of the first leg portion and the second leg portion;

interlocking the notches in the second end panel of each of the first leg portion and the second leg portion;

folding the end panels toward the surface opposed to the food-contacting surface along their respective fold lines; and

inserting at least a portion of each of the bias cut side panels into the respective receiving slot.

28. A blank for a construct, comprising:

a main panel; and

a first leg portion and a second leg portion joined to the main panel,

wherein

the first leg portion includes a plurality of panels joined along fold lines, and a tab extending from an edge of the first leg portion distal the main panel, and

the second leg portion includes a plurality of panels joined along fold lines, and a receiving slot dimensioned to receive the tab extending from the first leg portion.

29. The blank of claim 28, wherein the plurality of panels of the first leg portion includes

a connection portion extending from the main panel,  
a first panel joined to the connection portion along a first fold line, and  
a second panel joined to the first panel along a second fold line.

30. The blank of claim 29, wherein the plurality of panels of the second leg portion includes

a connection portion extending from the main panel,  
a first panel joined to the connection portion along a first fold line,  
a second panel joined to the first panel along a second fold line,  
a third panel joined to the second panel along a third fold line,  
a fourth panel joined to the third panel along a fourth fold line, and  
a fifth panel joined to the fourth panel along a fifth fold line.

31. The blank of claim 30, wherein the third fold line is interrupted by the receiving slot.

32. The blank of claim 28, further comprising a microwave energy interactive element overlying at least a portion of the main panel.

33. The blank of claim 32, wherein the periphery of the microwave energy interactive element defines a boundary between the connection portion and the main panel.

34. A tray for supporting a food item at an elevated position, the tray comprising:

    a platform including a first surface for supporting the food item; and

    at least one support element extending from a peripheral edge of the platform, wherein

        the support element includes a plurality of minor panels joined along fold lines, and

        at least one of the minor panels is disposed at least partially below the platform.

35. The tray of claim 34, further comprising a microwave energy interactive element overlying at least a portion of the main panel.

36. The tray of claim 34, wherein the plurality of minor panels includes:

    a first minor panel extending downwardly from the peripheral edge of the platform; and

    a second minor panel foldably joined to the first minor panel.

37. The tray of claim 36, wherein the second minor panel forms an acute angle with respect to the first minor panel.

38. The tray of claim 36, wherein the second minor panel forms an obtuse angle with respect to the first minor panel.

39. The tray of claim 36, wherein the second minor panel forms a right angle with respect to the first minor panel.

40. The tray of claim 36, wherein at least a portion of the second minor panel lies beneath the platform.

41. The tray of claim 34, wherein at least some of the minor panels of the support element define a substantially triangular shape in an elevational view of the support element.

42. The tray of claim 34, wherein at least some of the minor panels of the support element define a substantially polygonal shape in an elevational view of the support element.

43. The tray of claim 34, wherein at least a portion of the second minor panel extends upwardly through an opening in the main panel.

44. The tray of claim 34, wherein  
the support element includes a locking feature extending from at least one of the minor panels, and  
the support element is locked releasably to the platform by way of interaction between the locking feature and an opening in the platform.

45. The tray of claim 34, wherein  
the tray has a length that extends in a lengthwise direction,  
the platform has a length that extends in the lengthwise direction,  
the support element has a length that extends in the lengthwise direction,  
and

the length of the platform is greater than the length of the support element.

46. The tray of claim 34, wherein  
the support element is a first support element,  
the tray comprises a second support element a peripheral edge of the platform,  
the second support element includes a plurality of minor panels joined along fold lines, and  
at least one of the minor panels of the second support element is disposed at least partially below the platform.

47. The tray of claim 46, wherein the first support element and the second support element cooperate with one another to maintain the first support element and the second support element in a locked configuration.

48. The tray of claim 46, wherein  
the first support element includes a tab,  
the second support element includes a receiving slot dimensioned to receive the tab, and  
the tab cooperates with the receiving slot to maintain the first support element and the second support element in a locked configuration.

49. The tray of claim 46, wherein  
the first support element and the second support element each include a notch, and  
the notches cooperate with one another to maintain the first support element and the second support element in a locked configuration.

50. The tray of claim 34, further comprising a pair of substantially opposed, substantially upwardly extending handles joined to the platform.



2/22

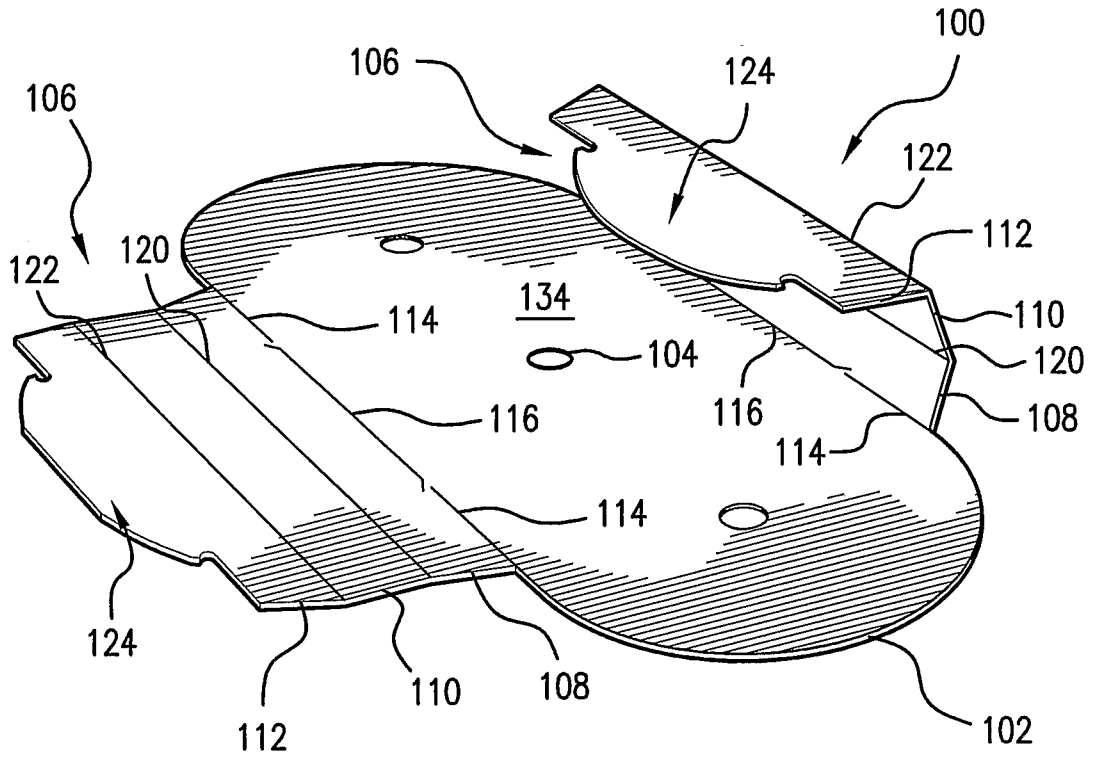

FIG. 1B

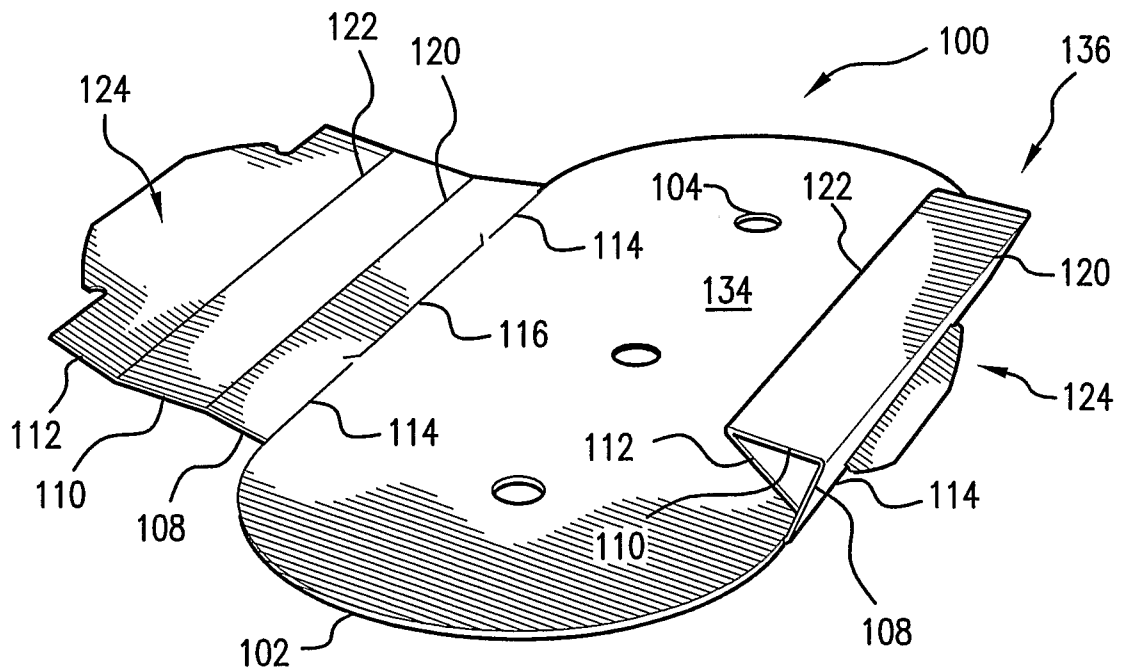

FIG. 1C

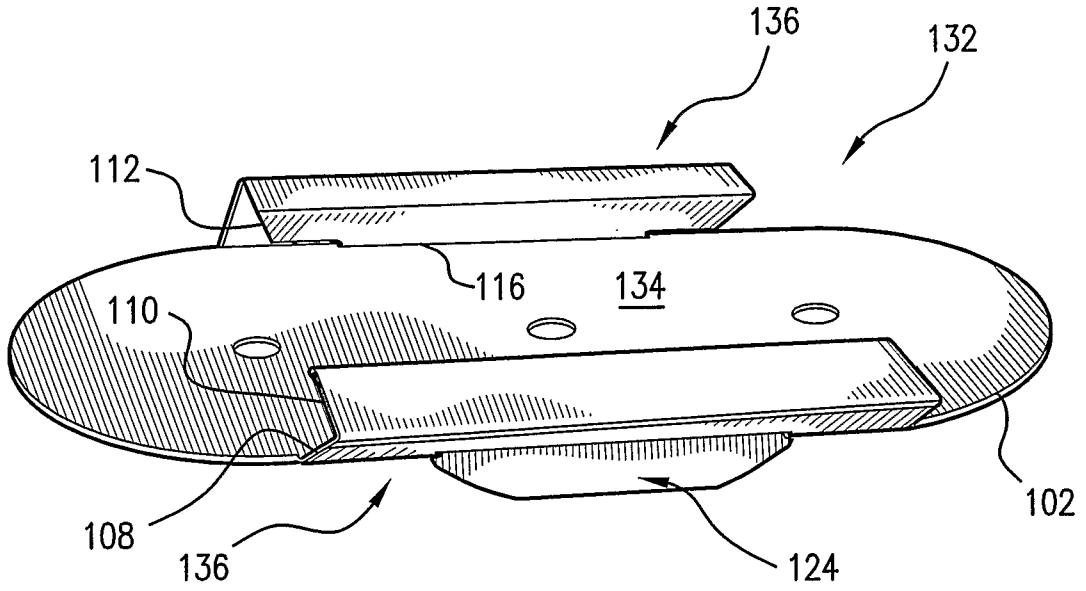

FIG. 1D

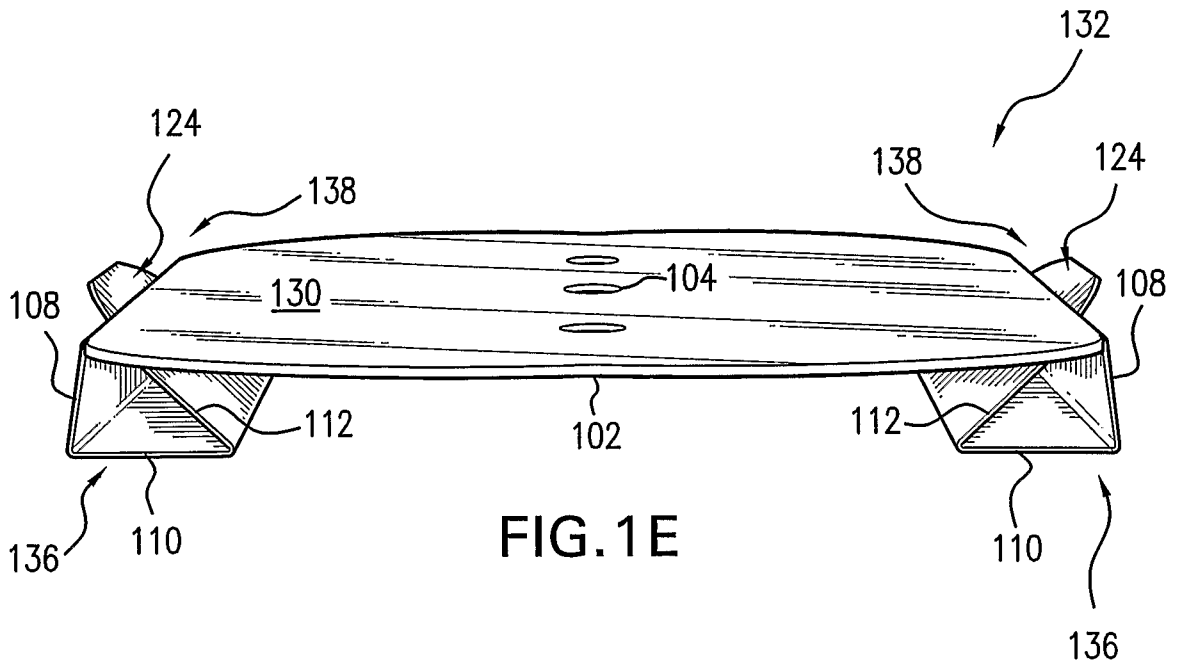

FIG. 1E

4/22

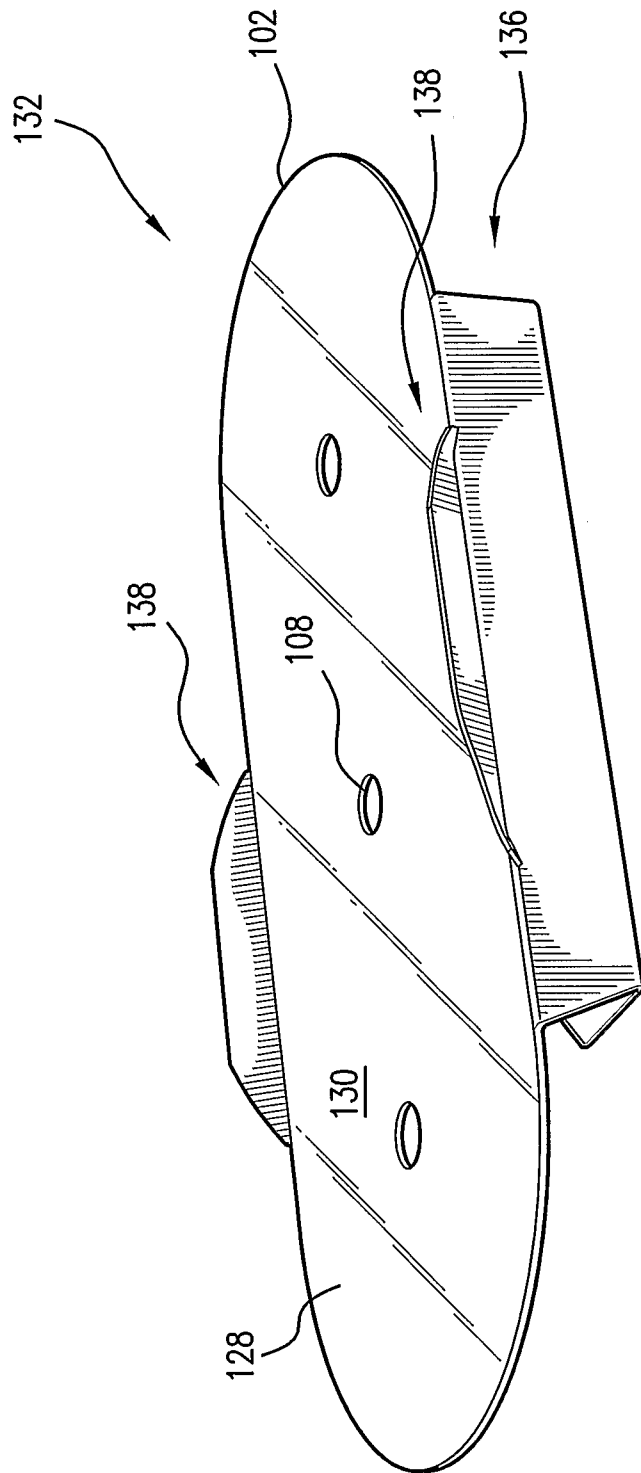

FIG. 1F

5/22

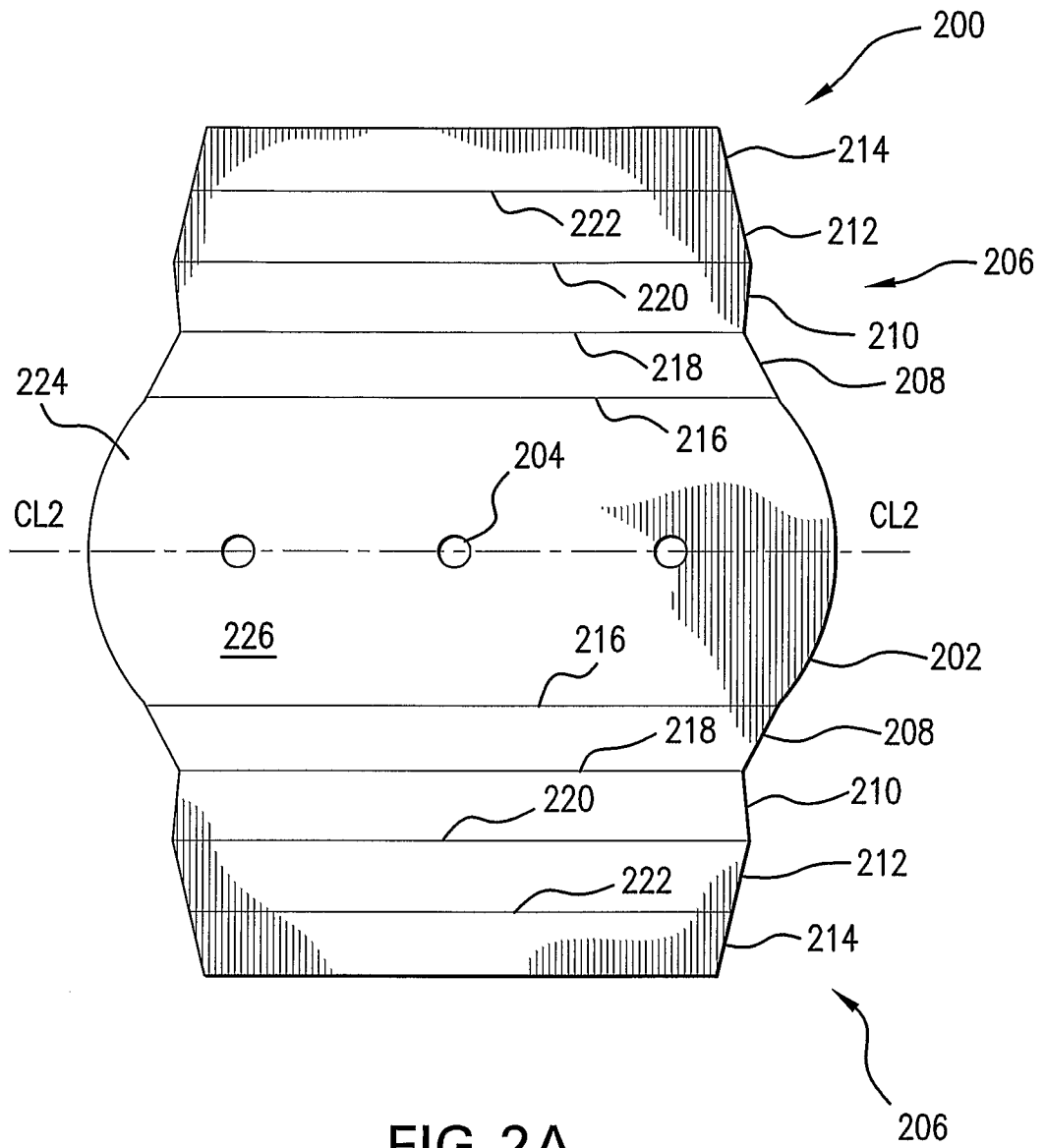
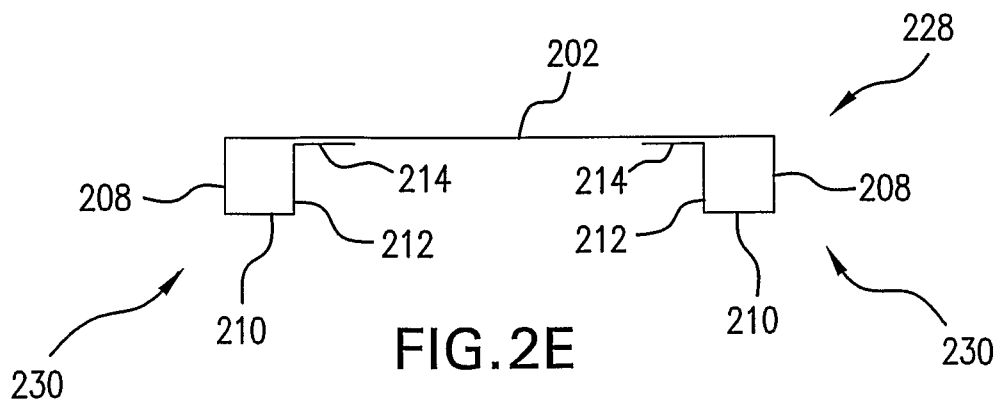
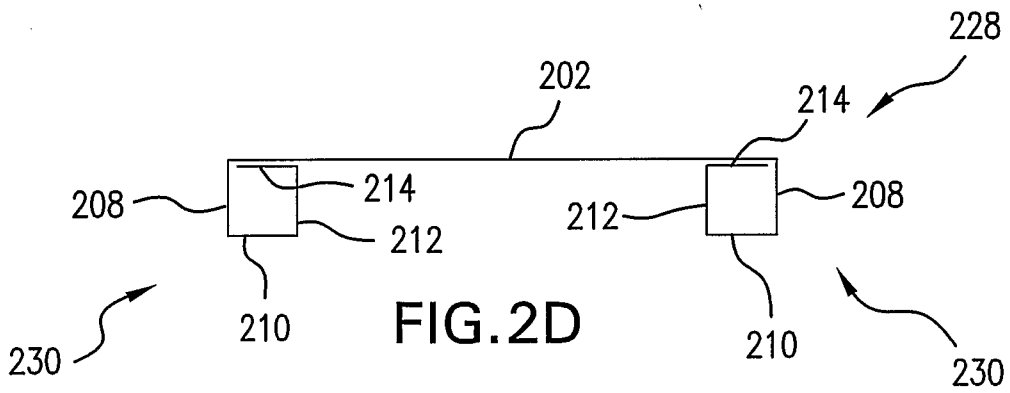
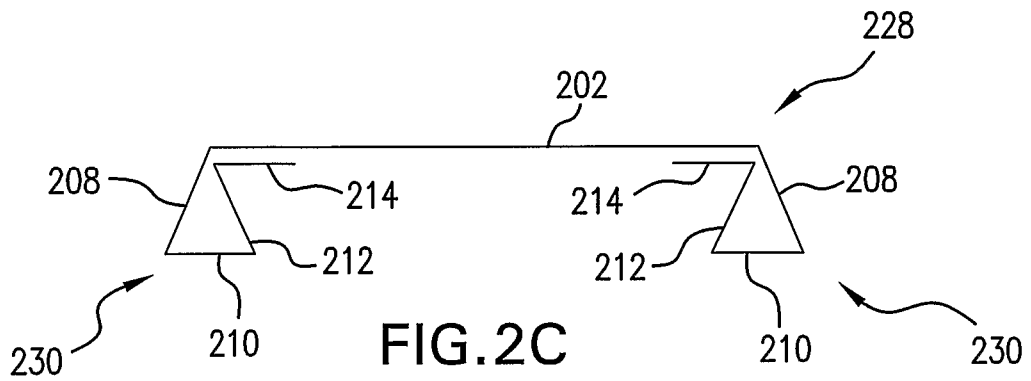
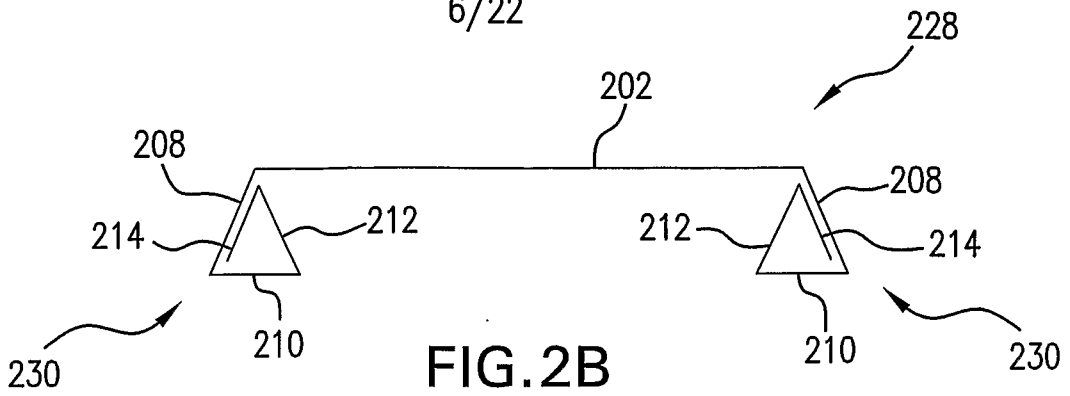

FIG. 2A

6/22



7/22

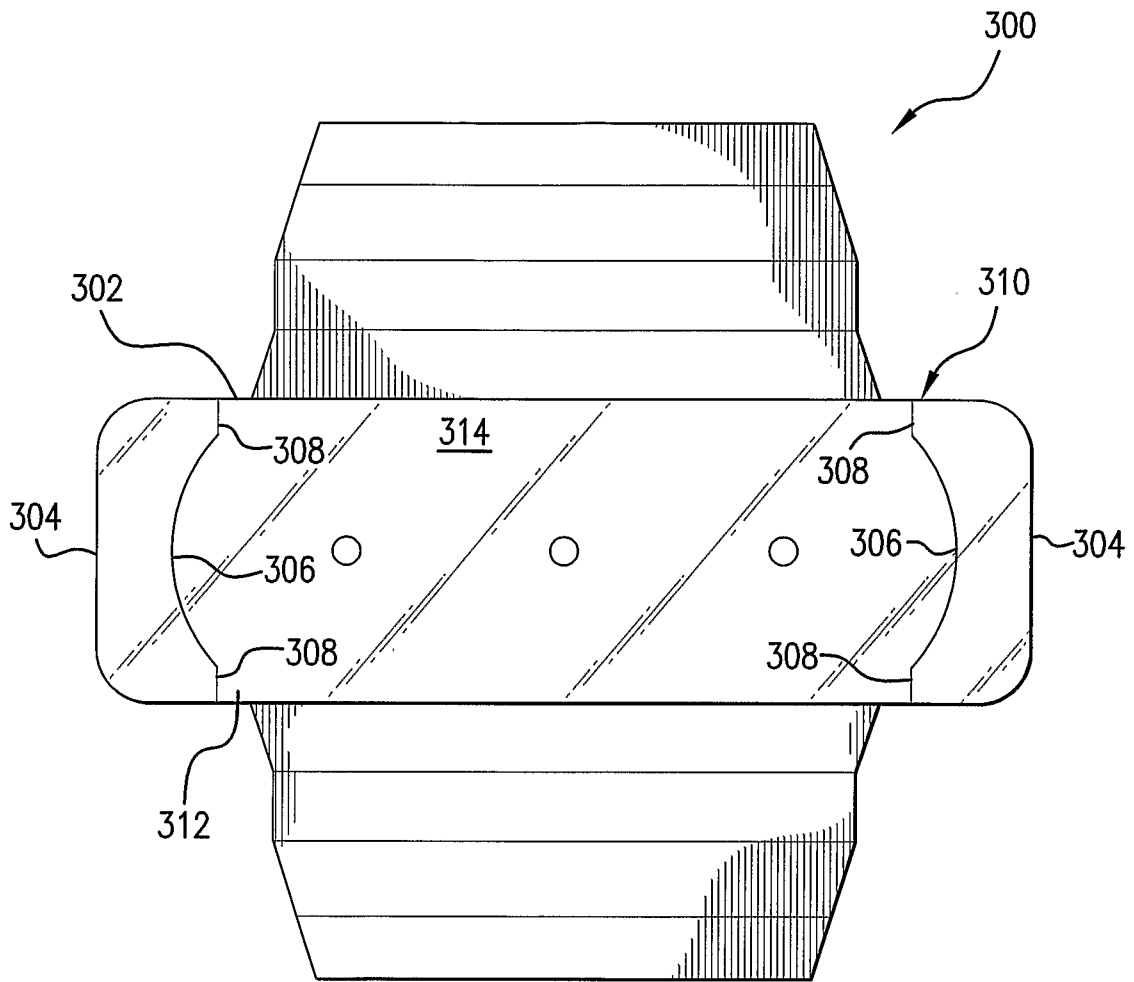

FIG.3A

8/22

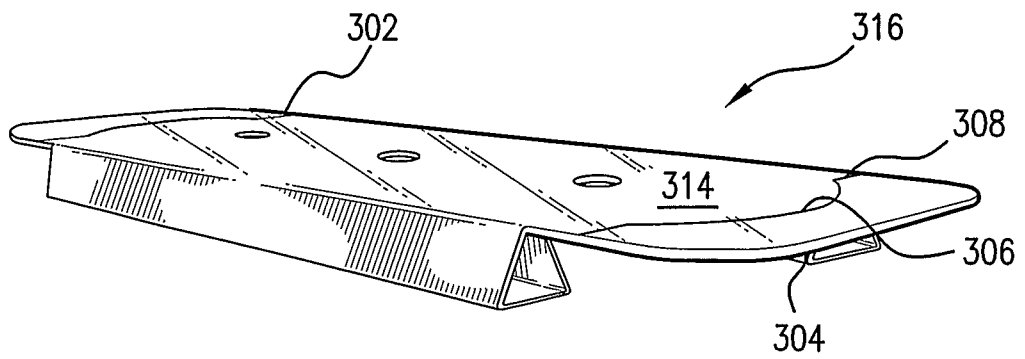
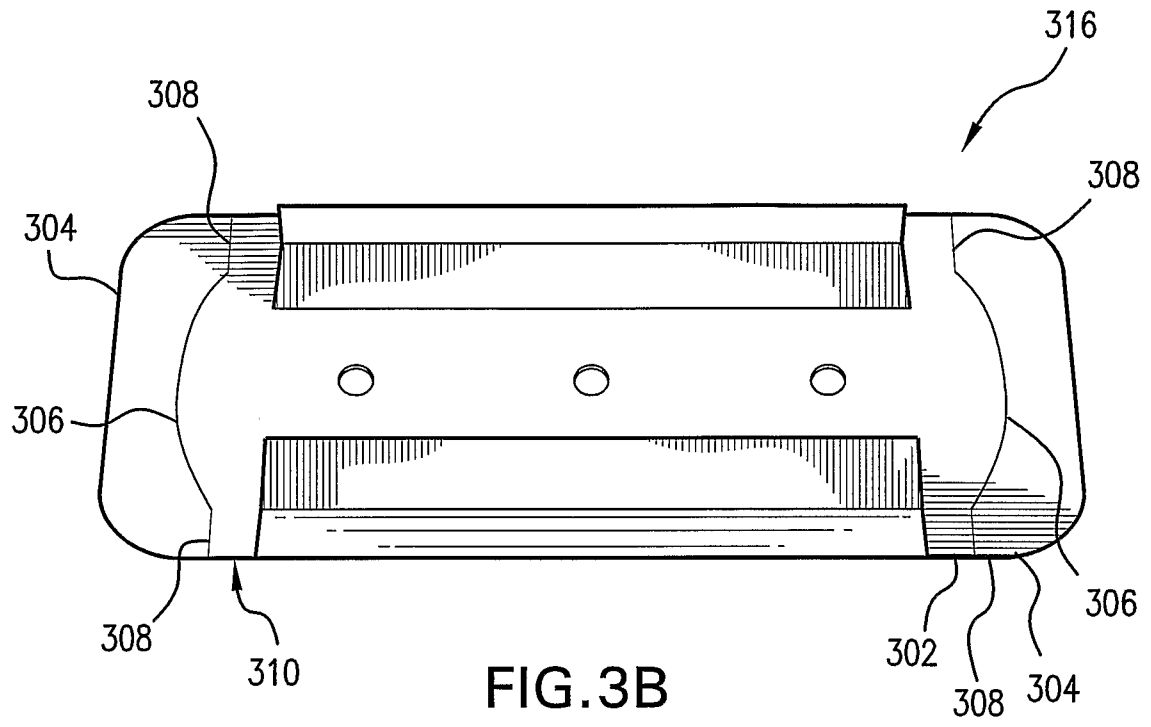

FIG. 3C

9/22

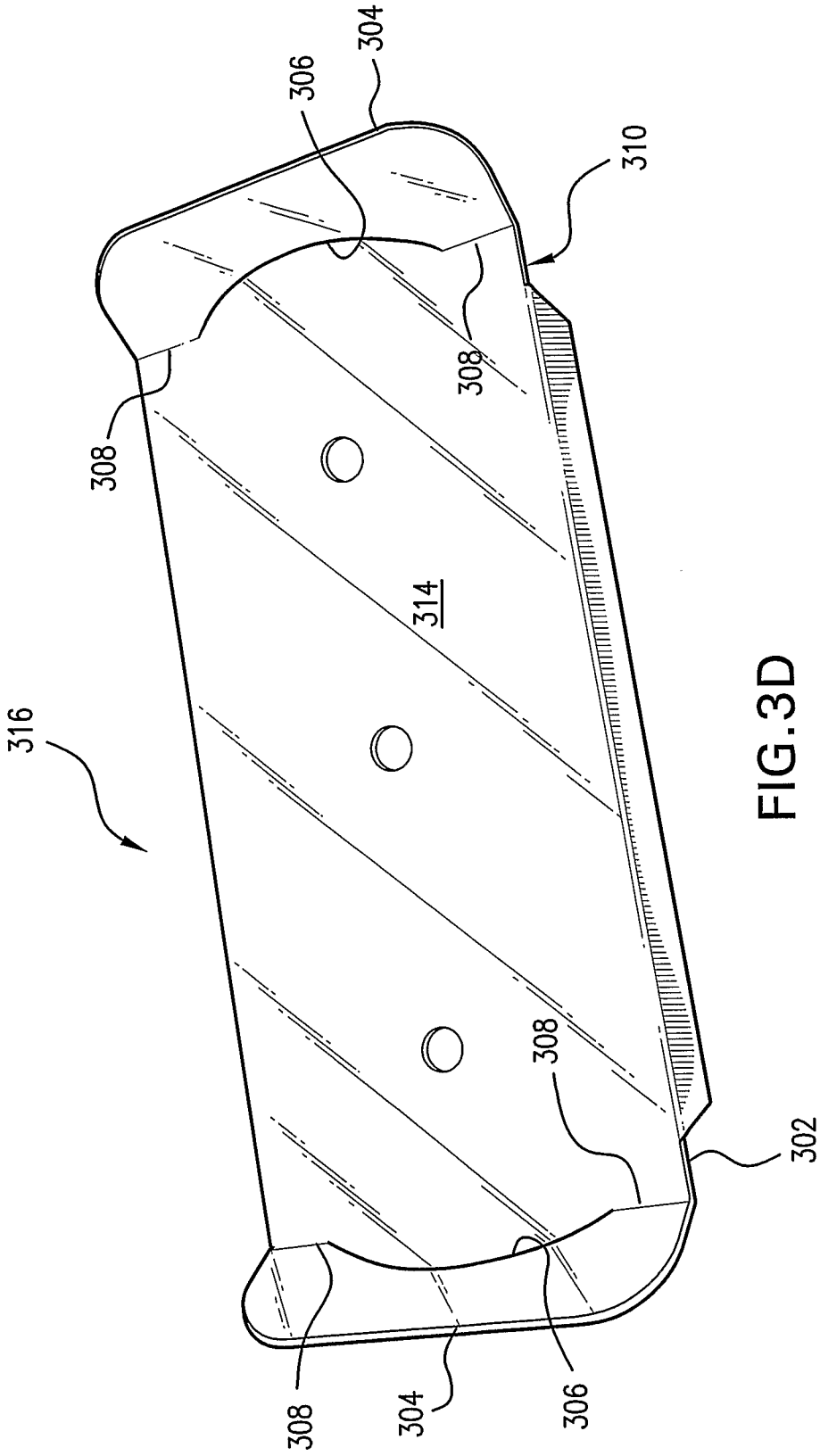

FIG. 3D

10/22

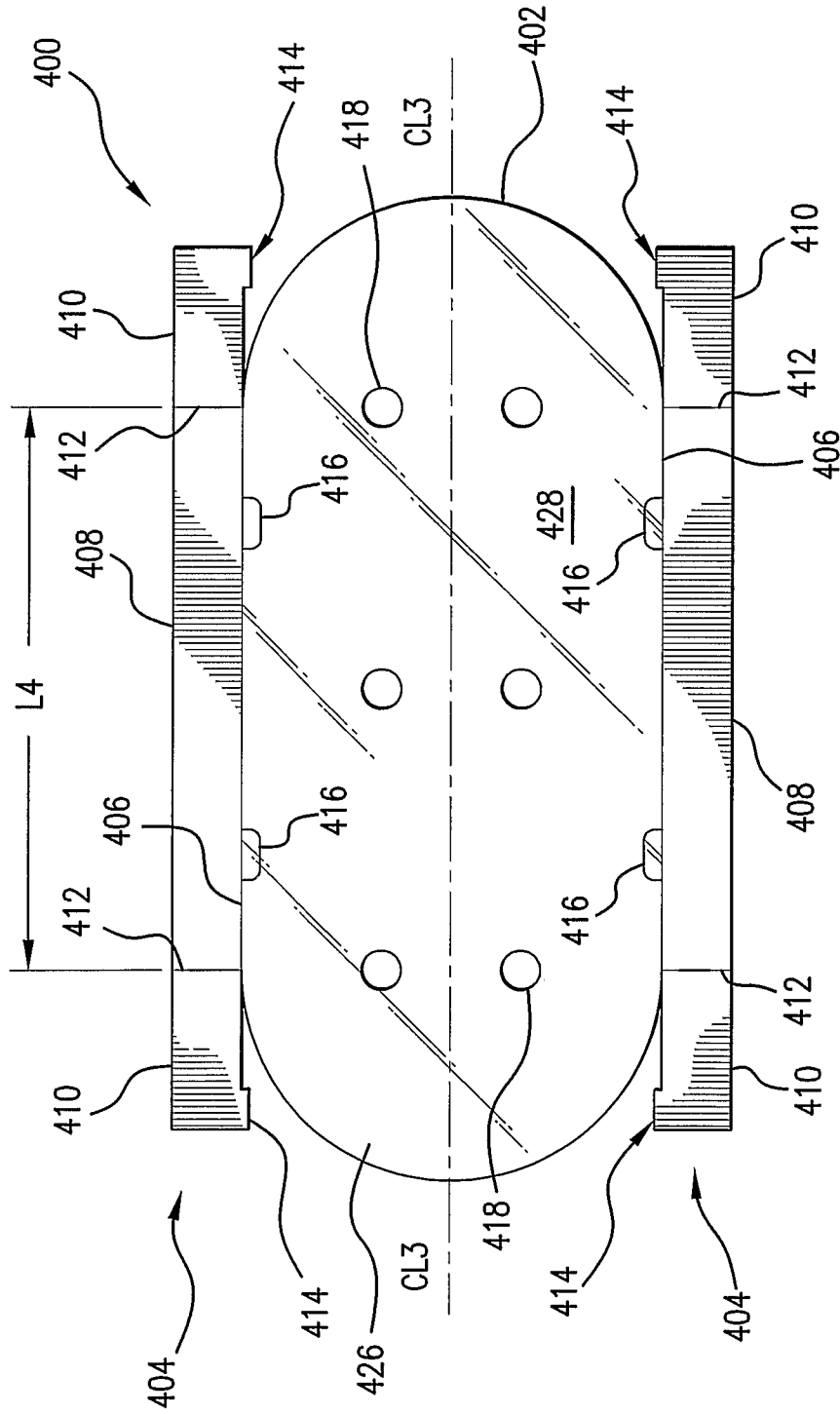
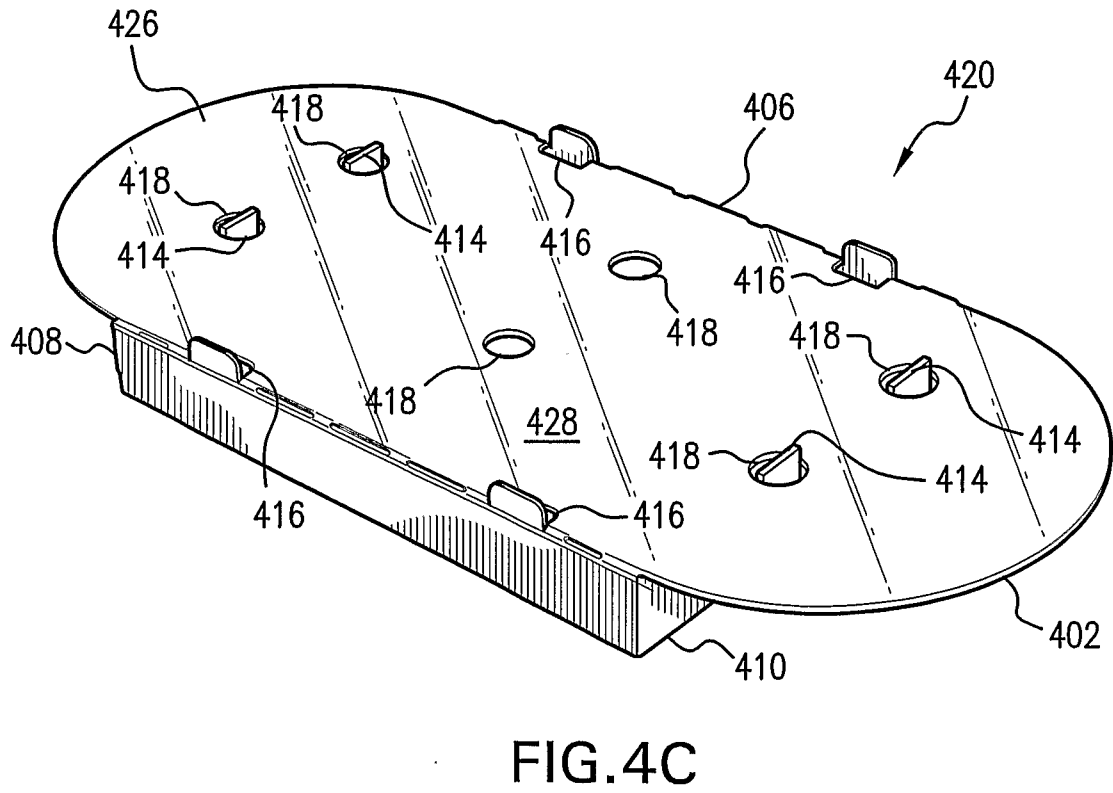
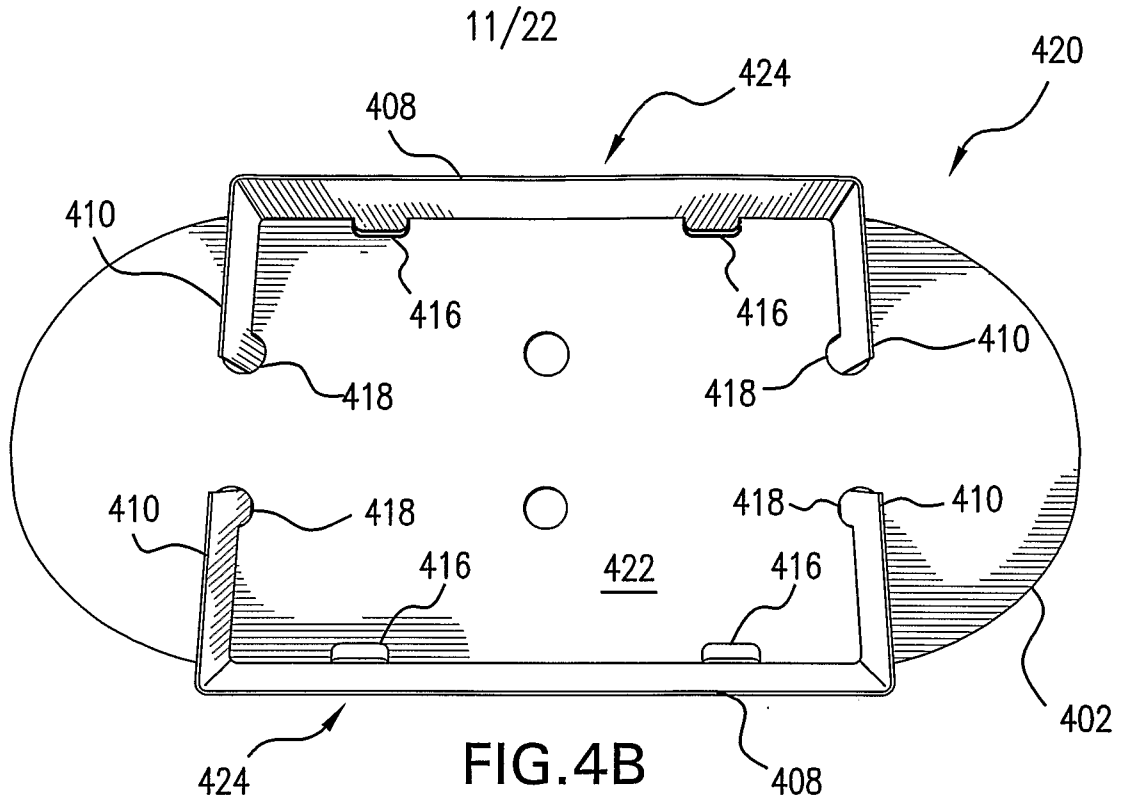

FIG.4A



12/22

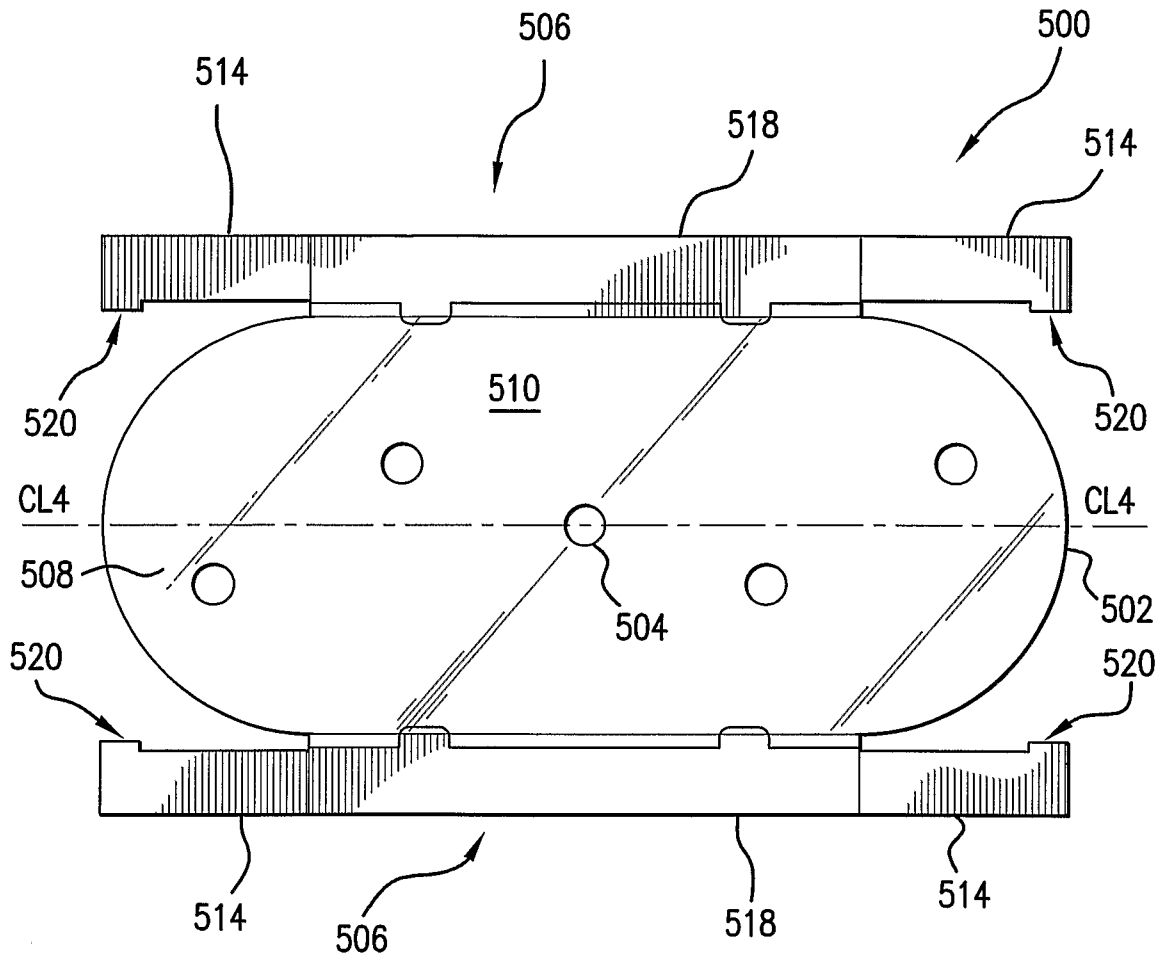

FIG. 5A

13/22

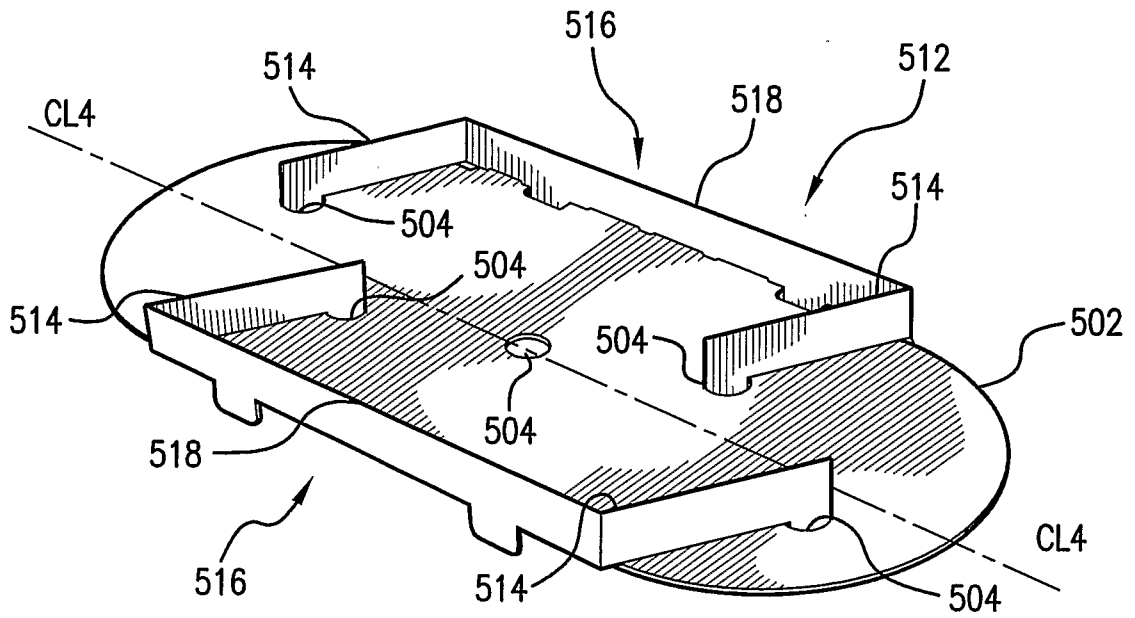

FIG. 5B

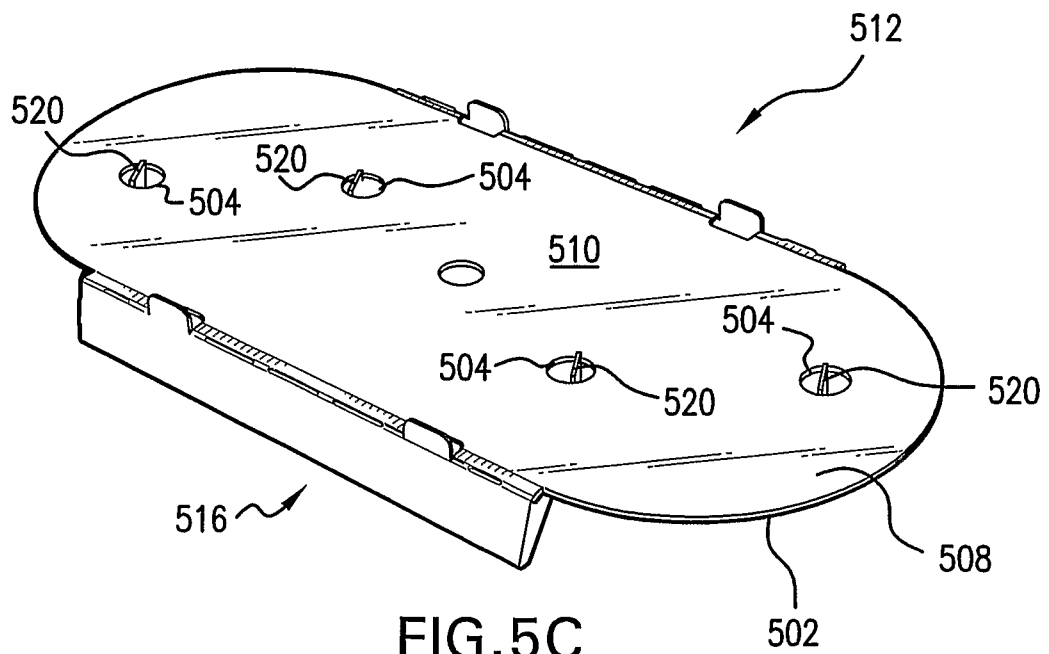

FIG. 5C

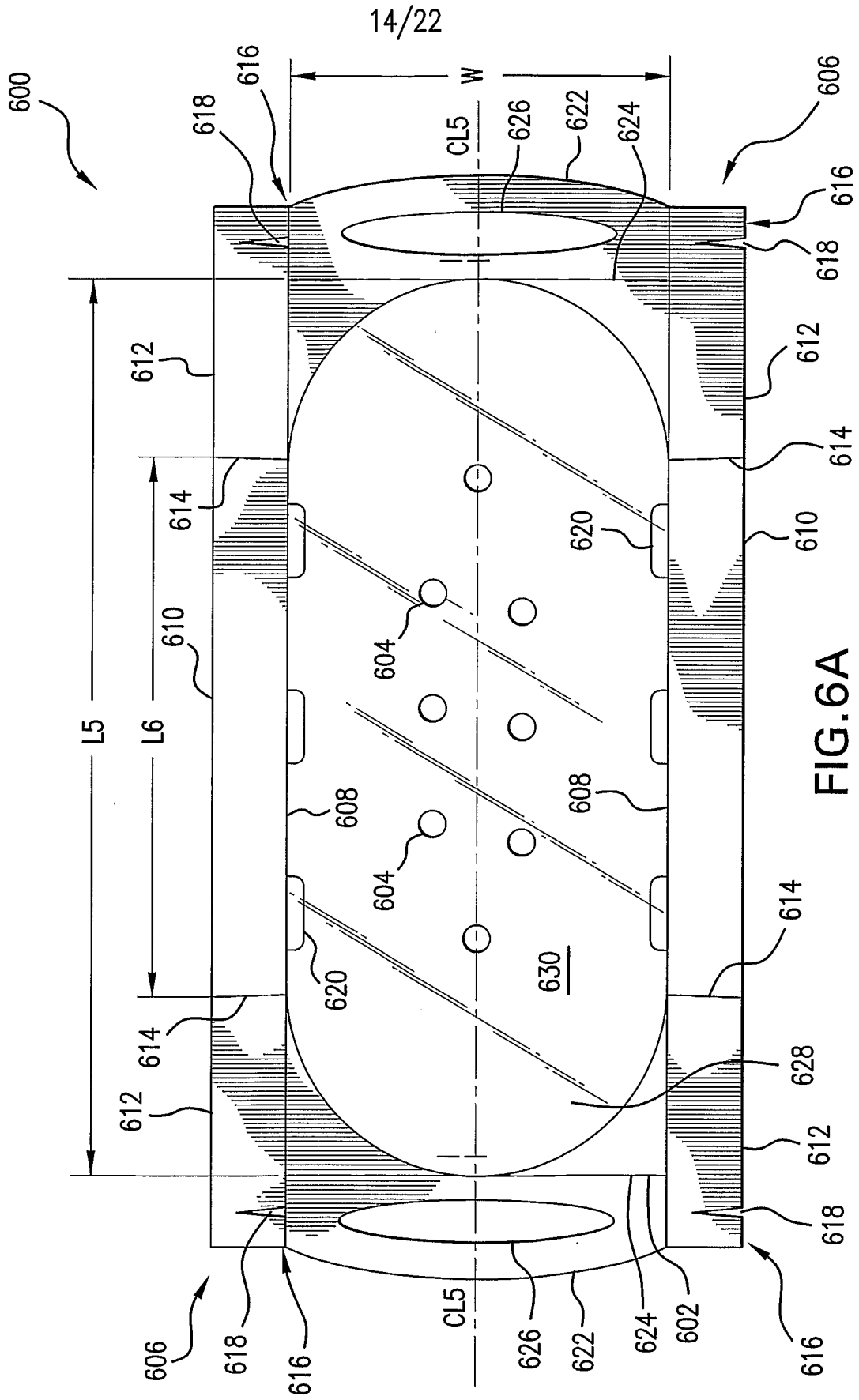

FIG. 6A



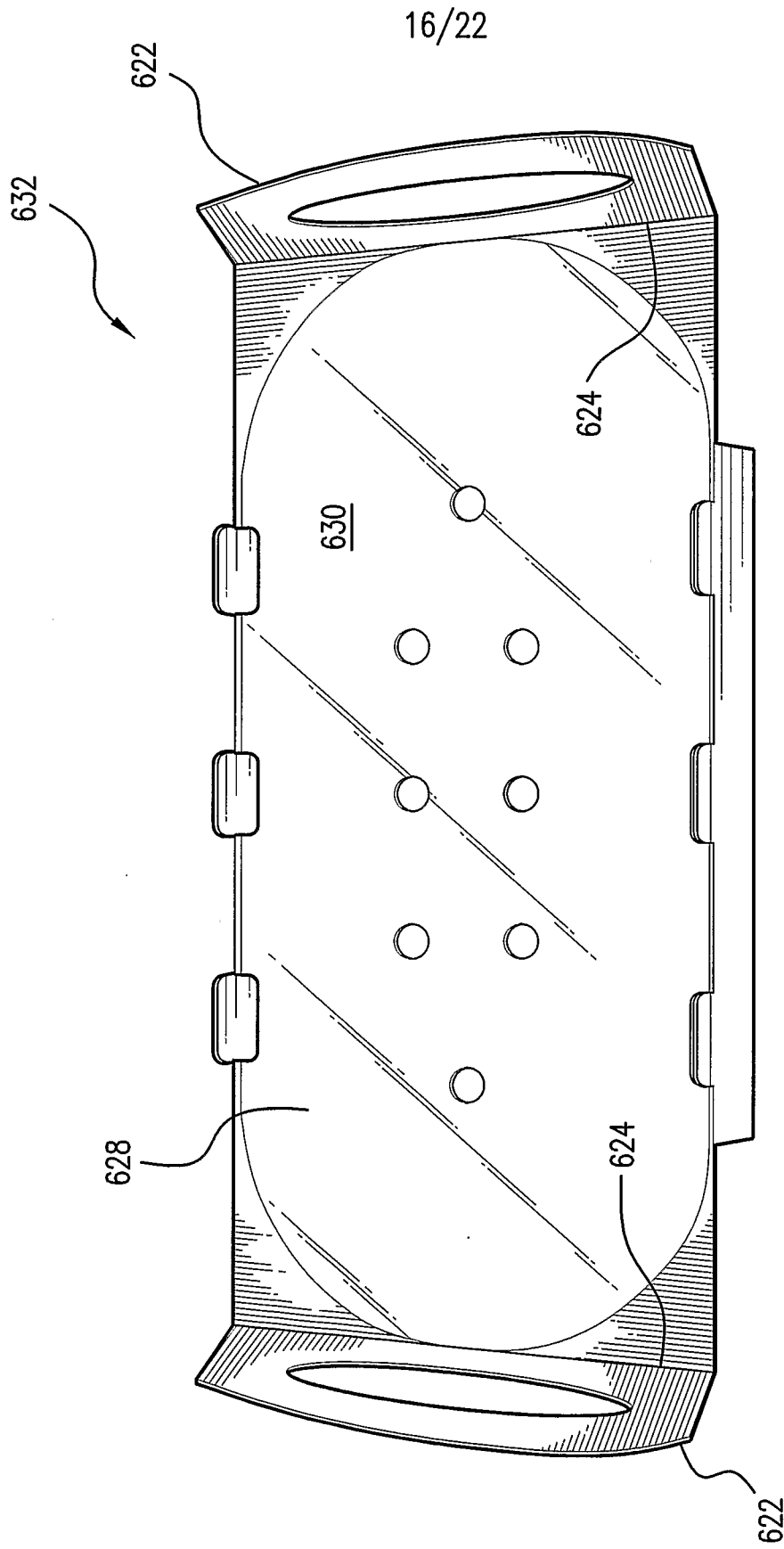

FIG. 6C

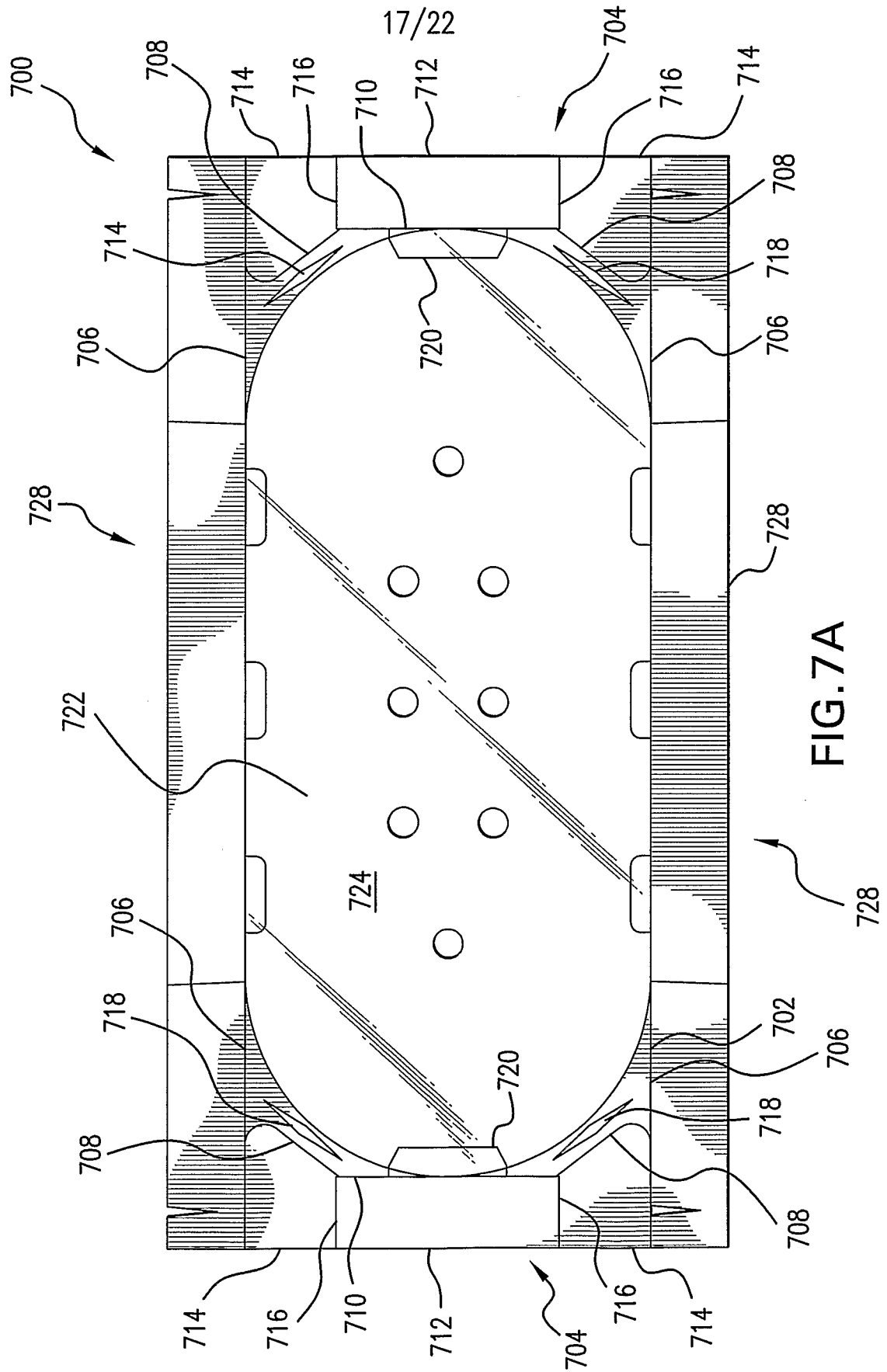

FIG. 7A

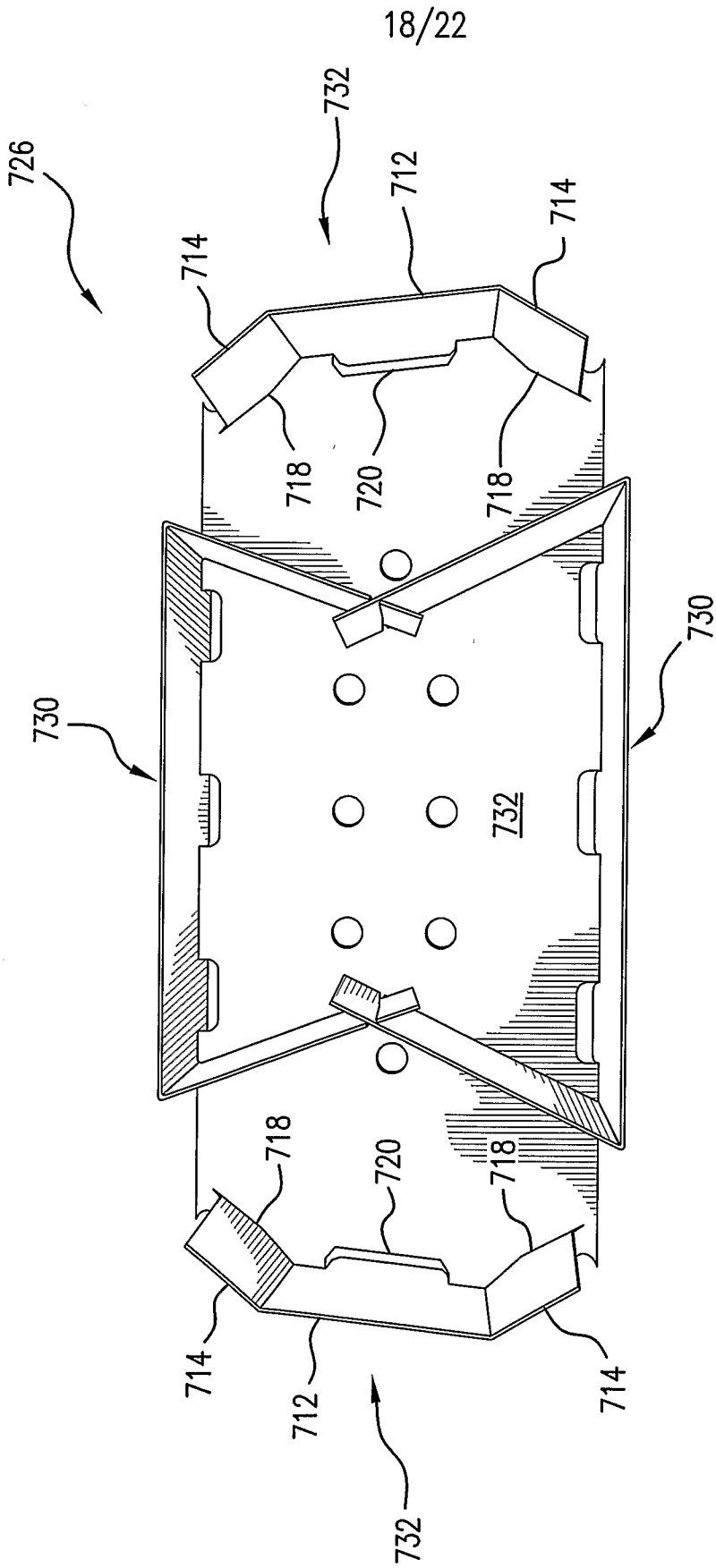

FIG. 7B

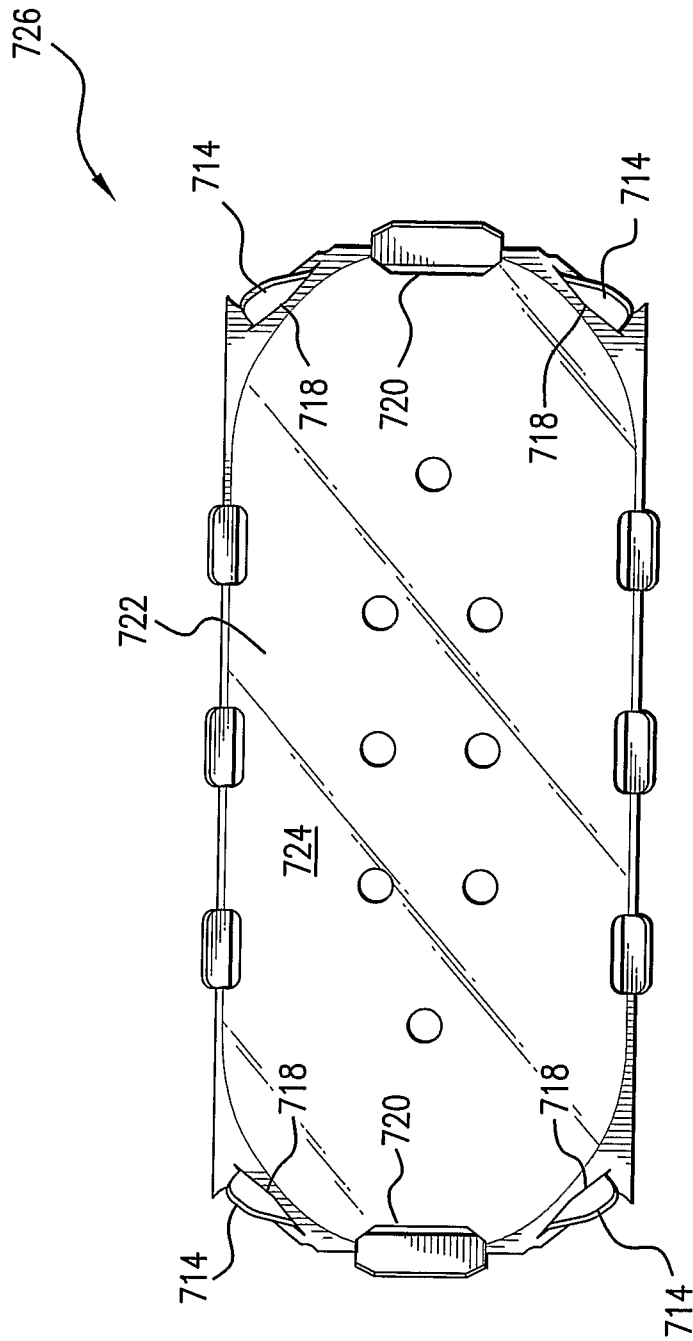

FIG. 7C



21/22

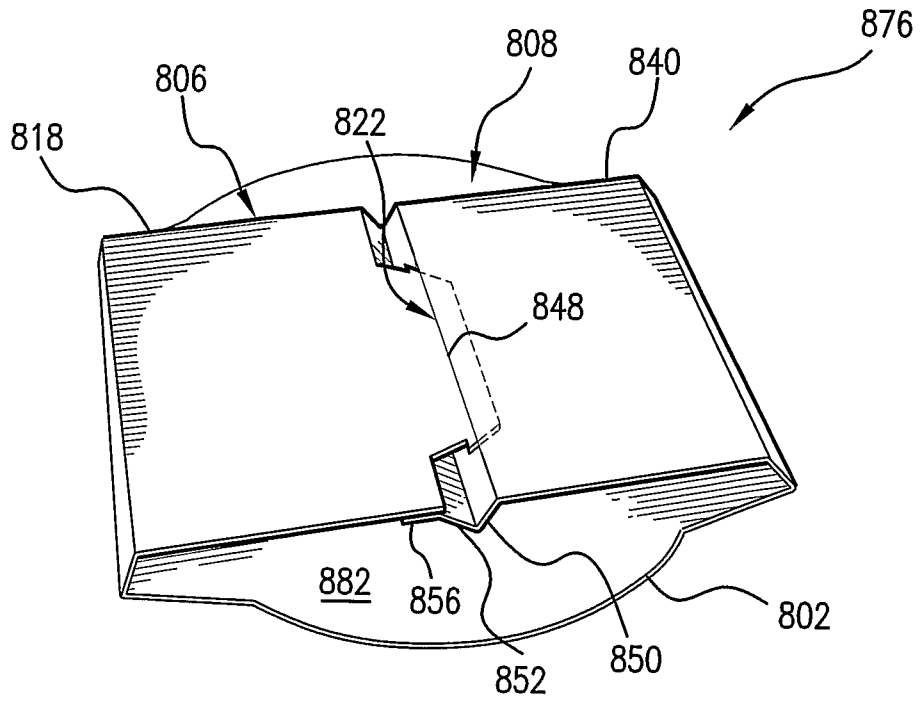

FIG. 8B

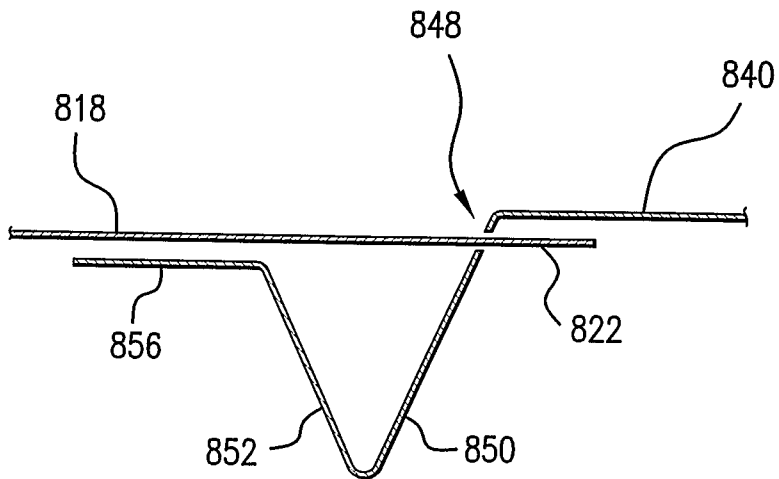

FIG. 8C

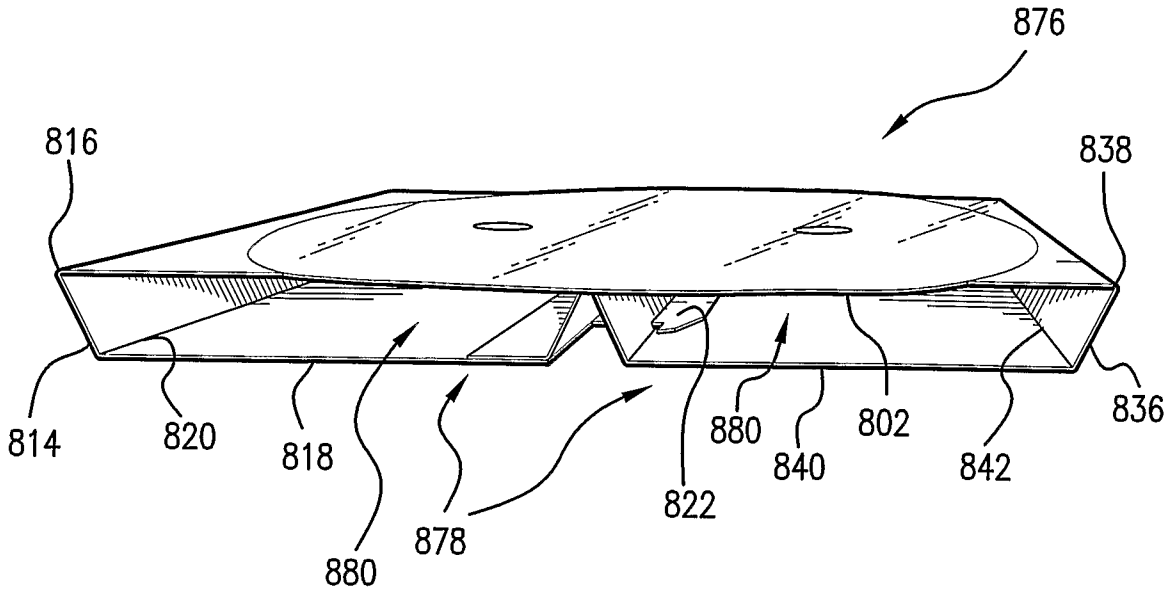

FIG. 8D

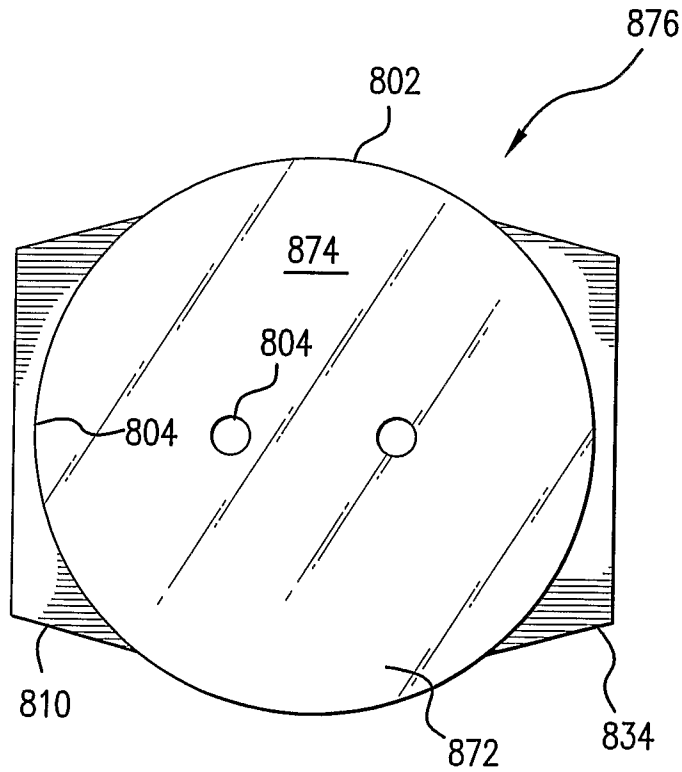

FIG. 8E

# INTERNATIONAL SEARCH REPORT

International application No  
PCT/US2006/035503

**A. CLASSIFICATION OF SUBJECT MATTER**  
INV. B65D81/34

According to International Patent Classification (IPC) or to both national classification and IPC

**B. FIELDS SEARCHED**

Minimum documentation searched (classification system followed by classification symbols)  
B65D H05B

Documentation searched other than minimum documentation to the extent that such documents are included in the fields searched

Electronic data base consulted during the international search (name of data base and, where practical, search terms used)

EPO-Internal

**C. DOCUMENTS CONSIDERED TO BE RELEVANT**

Category*	Citation of document, with indication, where appropriate, of the relevant passages	Relevant to claim No.
X	US 4 877 932 A (BERNSTEIN LINDA A [US] ET AL) 31 October 1989 (1989-10-31)	8-13, 34-36, 39,42, 46,50
Y	column 2, line 63 - column 4, line 22; figures 4-6	5,7,16, 21, 23-25, 32,45, 47-49
X	----- US 5 688 427 A (GALLO JR ANTHONY J [US]) 18 November 1997 (1997-11-18)	34-38, 40-46
Y	column 5, line 23 - column 5, line 61; figures 5-8	5,7,16, 21,32, 45,47,48
	----- -/--	

Further documents are listed in the continuation of Box C.

See patent family annex.

\* Special categories of cited documents :

"A" document defining the general state of the art which is not considered to be of particular relevance

"E" earlier document but published on or after the international filing date

"L" document which may throw doubts on priority claim(s) or which is cited to establish the publication date of another citation or other special reason (as specified)

"O" document referring to an oral disclosure, use, exhibition or other means

"P" document published prior to the international filing date but later than the priority date claimed

"T" later document published after the international filing date or priority date and not in conflict with the application but cited to understand the principle or theory underlying the invention

"X" document of particular relevance; the claimed invention cannot be considered novel or cannot be considered to involve an inventive step when the document is taken alone

"Y" document of particular relevance; the claimed invention cannot be considered to involve an inventive step when the document is combined with one or more other such documents, such combination being obvious to a person skilled in the art.

"&" document member of the same patent family

Date of the actual completion of the international search

12 December 2006

Date of mailing of the international search report

21/12/2006

Name and mailing address of the ISA/  
European Patent Office, P.B. 5818 Patentlaan 2  
NL - 2280 HV Rijswijk  
Tel. (+31-70) 340-2040, Tx. 31 651 epo nl,  
Fax: (+31-70) 340-3016

Authorized officer

Fitterer, Johann

## INTERNATIONAL SEARCH REPORT

International application No  
PCT/US2006/035503

C(Continuation). DOCUMENTS CONSIDERED TO BE RELEVANT		
Category*	Citation of document, with indication, where appropriate, of the relevant passages	Relevant to claim No.
X	GB 2 150 534 A (UNILEVER PLC) 3 July 1985 (1985-07-03)	1-3,6
Y	figures 1-3	5,7
X	GB 925 971 A (PAPELERA ESPANOLA S A) 15 May 1963 (1963-05-15)	1,2,4,6
Y	figures 1,2	5,7
X	US 5 544 806 A (ANDERSON THOMAS J [US] ET AL) 13 August 1996 (1996-08-13)	14,15, 17,18
Y	figures 2,3	16
X	FR 745 013 A (DUREYSEN) 1 May 1933 (1933-05-01)	19,20,22
Y	figures 1,2	21, 23-25,49
X	FR 961 269 A (MALESIEUX) 9 May 1950 (1950-05-09)	19,20,22
Y	figures 1,2	21,23,24
X	US 4 192 540 A (OLIFF JAMES R [US]) 11 March 1980 (1980-03-11)	28-31,33
Y	figures 1,3	32,47,48
Y	US 4 505 391 A (KUCHENBECKER MORRIS W [US]) 19 March 1985 (1985-03-19)	45
A	WO 93/19566 A (GOLDEN VALLEY MICROWAVE FOODS [US]) 30 September 1993 (1993-09-30)	1-50
	figures 1-18	

# INTERNATIONAL SEARCH REPORT

Information on patent family members

International application No PCT/US2006/035503
---

Patent document cited in search report	A	Publication date	Patent family member(s)	Publication date
US 4877932	A	31-10-1989	NONE	
US 5688427	A	18-11-1997	US 5510132 A	23-04-1996
GB 2150534	A	03-07-1985	NONE	
GB 925971	A	15-05-1963	NONE	
US 5544806	A	13-08-1996	CA 2179959 A1	23-02-1997
FR 745013	A	01-05-1933	NONE	
FR 961269	A	09-05-1950	NONE	
US 4192540	A	11-03-1980	NONE	
US 4505391	A	19-03-1985	NONE	
WO 9319566	A	30-09-1993	EP 0630552 A1 JP 7505109 T	28-12-1994 08-06-1995