

W. PAINTER. BOTTLING MACHINE.

No. 438,708.

Patented Oct. 21, 1890.

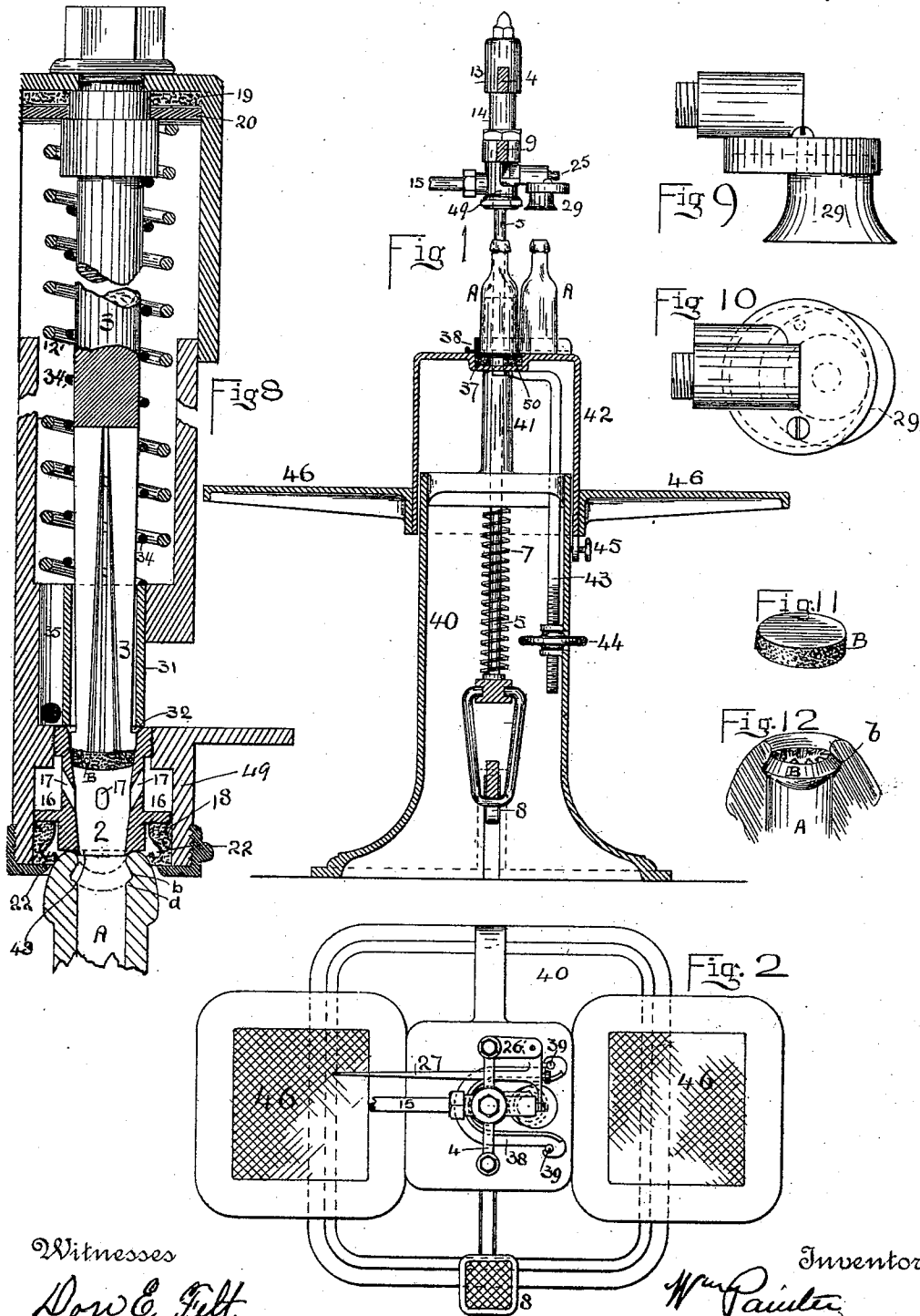

Witnesses

Dow C. Felt.
J. B. McSinn.

Inventor

Wm Painter

By his Attorney

R. D. Jones

(No Model.)

2 Sheets—Sheet 2.

W. PAINTER. BOTTLING MACHINE.

No. 438,708.

Patented Oct. 21, 1890.

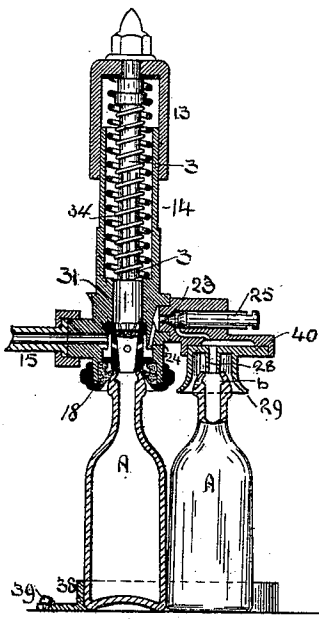

Fig. 6.

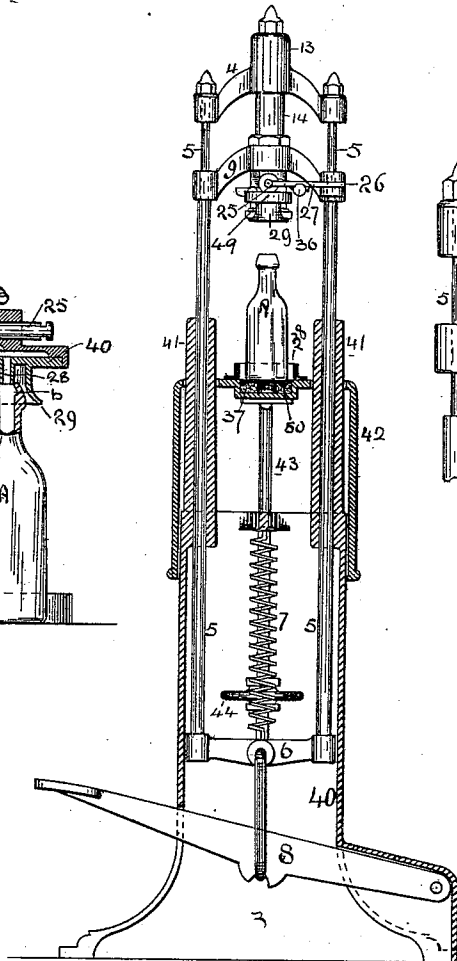

Fig. 3.

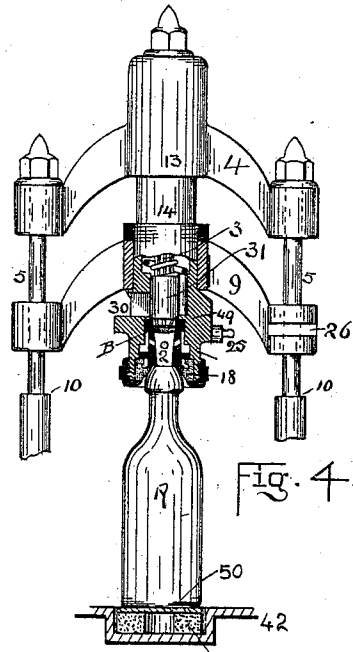

Fig. 4.

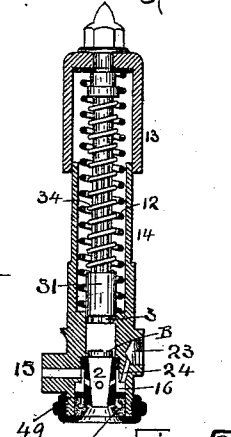

Fig. 5.

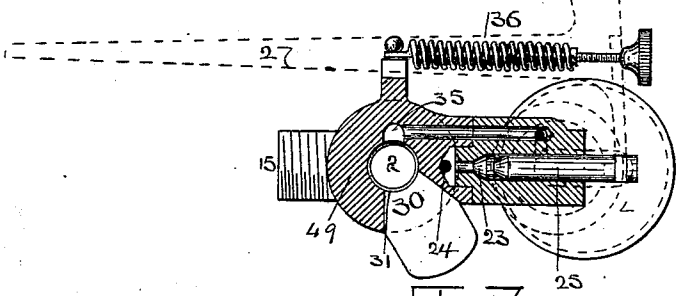

Fig. 7.

Witnesses
Dow E. Felt
J. B. Mc Giv.

By his Attorney

Inventor
W. Painter
R. J. Smith

UNITED STATES PATENT OFFICE.

WILLIAM PAINTER, OF BALTIMORE, MARYLAND.

BOTTLING-MACHINE.

SPECIFICATION forming part of Letters Patent No. 438,708, dated October 21, 1890.

Application filed October 1, 1887. Serial No. 251,171. (No model.)

To all whom it may concern:

Be it known that I, WILLIAM PAINTER, of Baltimore, in the State of Maryland, have invented new and useful Improvements in Bot-
5 tling-Machines; and I do hereby declare that the following is a full and accurate description of the same, reference being had to the accompanying drawings, wherein—

Figure 1 is a front vertical sectional elevation of my machine. Fig. 2 is a plan of the
10 same. Fig. 3 is a side vertical elevation of the same. Fig. 4 is a side elevation, partly in section, of the corking devices. Fig. 5 is a front central section of the bottling devices,
15 including the corking mechanism in initial position. Fig. 6 is a front central section of the corking device in the position assumed during bottle-filling. Fig. 7 is a horizontal
20 section through the snift-valve. Fig. 8 is a vertical section of the corker enlarged. Fig. 9 is a side elevation of the snifter-bell. Fig. 10 is a plan of the same. Fig. 11 is a perspective
25 view of one of my stopper-disks. Fig. 12 represents the same in the form it assumes in the bottle-mouth.

Disk stoppers such as shown in my patent, No. 327,099, dated September 29, 1885, are formed of disks of suitable elastic material,
30 which, being compressed circumferentially, assume an arched or dome-shaped form, and when inserted in the bottle-mouth with the convex side inward and the concave side outward and the edge resting in an interior circumferential
35 groove in the bottle-mouth, the resiliency of the material causes the edge to press outwardly into said groove. Therefore pressure against the convex side is translated into lateral pressure, so that such a stopper
40 will remain in its place and resist internal pressure in accordance with the mechanical principles which control the action of an arch, as fully set forth in said patent.

The principal object of my invention is to facilitate the insertion of said stoppers, and
45 in connection therewith to fill the bottles with effervescing liquids without the usual waste in snifting. A further object is to simplify the general machinery.

The following description and claims will
50 fully distinguish the points of the invention.

A is a bottle provided with the internal

groove *a* in its mouth, adapted to receive the edge of the disk-stopper B, such as is described and claimed in my patent above referred to, and shown herein in Figs. 11 and 12. 55

The first part of my invention refers to mechanism for inserting said stoppers, which are prepared beforehand in the form of disks,
60 as described in my patent referred to. I provide a holder for the bottle and a tapering throat-piece 2, fitted in a proper holder or head stock for the same. (See Fig. 8.) At its upper end this throat-piece is equal to the diameter of the disk B, and at its lower end its diameter equals the diameter of the bot-
65 tle-mouth, and it is provided with a slightly-projecting sharp-edged ledge 48, (see Fig. 8,) to facilitate the passage of the stopper from the throat 2 into the mouth of the bottle. This ledge or lip also assists in accurately
70 centering the bottle-mouth with the throat. The disk B is laid in the upper end of the throat-piece, as shown in Fig. 5, and is thereafter forced down through said tapering throat into the bottle-mouth. Its movement
75 through the contracting passage of said throat causes it to be compressed edgewise and arched, and the friction against the wall of the throat will so retard the edges that the disk will invariably assume a downward con-
80 vexity. When the disk has passed through the throat 2 into the mouth of the bottle, its resiliency causes it to expand into the groove *b*, from which it cannot be expelled by the internal pressure distributed evenly over its
85 convex surface.

To force the disk down through the tapered throat 2, a collapsible plunger or piston is employed. A collapsible plunger is desirable, because it is necessary that it shall
90 pass through the smaller end of the throat 2, and if it does not also fill said throat at the larger end there is liability that the edge of the disk will be squeezed between the plunger and the throat. I have made a satisfactory
95 plunger 3 by slitting a tube of proper size—*i. e.*, having a diameter equal to the larger end of the throat 2. The slits are, say, eight in number, and they extend a sufficient distance to make the plunger-fingers thus
100 formed long enough to possess the desired degree of elasticity. Such a plunger is shown

in longitudinal section in Fig. 8 and in elevation in Fig. 5. The disk B being laid upon the upper end of the throat 2, the plunger 3 is caused to descend. The slitted end of
 5 said plunger engages the disk all around at its extreme edge and forces it bodily down through said throat, the end of the plunger following down the taper of the throat, collapsing as it goes and following the disk
 10 until it rests in the groove *b*.

In the machine shown in the drawings the plunger 3 is attached to a yoke 4, which is attached at its ends to side rods 5 5, the lower ends of which are connected with a yoke 6,
 15 provided with a treadle 8, to which the operator's foot may be applied to depress the plunger, and a strong spring 7 to raise it again after having been depressed. This is the essential apparatus whereby the stoppers
 20 are inserted in the bottle, and it includes all that is necessary when the bottles contain still liquids or those which become effervescent after being stoppered.

For liquids which are effervescent at the time of bottling, and which are therefore bottled under pressure, additional devices are required. I therefore provide another yoke 9, with a head-stock 49, in which the throat-piece 2 is carried, and for convenience the
 30 yoke 9 is mounted on the same guide-rods 5 5 which carry yoke 4. The rods 5, however, pass freely through said yoke, their relative movement being limited in one direction by the shoulders 10 on the rods 5, and in the
 35 other direction by engagement with yoke 4. A strong spring 12 is introduced between in the head-stock 49 to keep the yoke 9 normally in contact with shoulders 10, or the weight of yoke 9 and its attachments may
 40 in some cases be sufficient to keep yoke 9 down against the shoulders 10. The effect of this is to make both yokes operative by the same treadle. A bottle having been put in position, depression of the treadle 8 brings
 45 both yokes down together. The throat-piece 2 and yoke 9 are arrested when the former encounters the bottle; but the spring 12 then yields, and yoke 4, with the plunger 3, continues to descend until the stopper has been
 50 forced into position in the bottle-mouth. At the proper moment—that is, when the stopper has been forced exactly to the right distance—the plunger is arrested by the engagement of the yokes 4 and 9, and this point
 55 of arrest is correctly ascertained and determined by proper adjustment.

For the proper protection of the spring 12 and plunger 3, I provide at the middle of the yoke 4 a hollow cylindrical hood 13, to the
 60 top of which the plunger 3 is rigidly secured. I also provide at the middle of yoke 9 a cylindrical sleeve 14, which constitutes the upper end of the head-stock 49. It enters and slides within said hood. The plunger 3 and
 65 spring 12 are inclosed, concealed, and protected by this telescopic case 13 14, and the downward motion of yoke and plunger is

gaged and cushioned by a rubber ring 19, protected by a ring of brass 20 and washers of thin metal for adjustment.

The pump or other means for conveying
 70 liquid under pressure to the machine is coupled to the inlet-pipe 15, and the flow into and through said inlet is controlled by a proper valve, (not shown,) but convenient to the
 75 operator's hand. The liquid to be passed into the bottle passes from the inlet 15 to the annular chamber 16 and thence through the ports 17 into the throat 2 and down into the
 80 bottle, the stopper B having previously been forced into the upper end of the throat down nearly to the ports, as shown in Fig. 8, so as to prevent the escape of liquid upward through the throat.

The ports 17 in the throat are made highly
 85 oblique, as shown, so that the stopper will slide easily over such ports. The throat 2 is made cylindrical at the place where the ports 17 enter, so that the stoppers may pass over said ports without suffering any additional
 90 compression and consequent abrasion.

At the bottom of throat 2 there is an elastic gasket 18 to close around the bottle-head. It is necessary, however, that the bottle shall come into contact with the throat-piece, be-
 95 cause the descent of the plunger into the bottle-neck must be gaged quite exactly, in order that the stopper-disk may be pushed fully into its seat, but not forced down past the
 100 shoulder *d* at the lower side of the groove *b*. Therefore the gasket 18 is made thin and undercut, as at 22. This makes the gasket more yielding, so as to accommodate varying sizes of bottle-heads. Gas and liquid which may
 105 pass behind this thin edge will tend to make it close the more tightly around the bottle-head.

When bottling fluids under pressure, it is required that the connection between the bottle and the source of supply shall be practically
 110 air-tight. To this end the disk B is forced part way down the throat 2 to close the same at the top, while the gasket 18 closes it below when in contact with the bottle, as
 115 shown in Figs. 4, 6, and 8. Under these conditions fluid will pass into the bottle A until the air therein has been compressed and the pressure in the bottle has become equal to the pressure of service. There will still remain the original quantity of air in the bottle,
 120 and it is necessary to permit this to escape. This is called "sniffing." To accomplish it, it is necessary to open the escape-way suddenly and close it again quickly, so that the confined air will escape with a gush before the superior inertia of the heavier liquid is overcome. In that way the smallest quantity of liquid will be blown out with the air. If the confined air is permitted to escape slowly, the liquid under pressure will
 125 escape with it. It is a practice to sniff by slightly and momentarily raising the throat-piece from the top of the bottle and permitting the air to escape in that way. The quan-

tity of fluid lost in that way is material and has been estimated at about ten percent. I prevent all such waste by a snifting-valve and duct which will convey the wasting fluid to a bottle properly located and next in order for filling, so that the fluid escaping in snifting one bottle enters another placed alongside of it. By thus snifting into the bottle next to be filled practically all atmospheric air is expelled and its place occupied by the snifted liquid and the heavy carbonic-acid gas disengaged therefrom. When, therefore, the second bottle is removed to the filling-head, it is chiefly occupied by such gas instead of by air. It is found by experience that beverages bottled in this manner have a much better quality and stability.

It is to be understood that I do not limit the use of my method of saving the snift by discharging it into the next bottle to be filled to the bottling-machine herein described, because it is evident that this part of my invention is also adapted to ordinary corking or bottling machines. To this end I make a lateral port 23, which communicates with the chamber 16 by the passage 24, and close said port with valve 25. The yoke 9 is provided with a laterally-extending lug 26, to the extremity of which I pivot one arm of the lever 27, conveniently made T-shaped, with the handle end extended parallel with the inlet-pipe 15 and the free arm in engagement with the valve 25. The handle end is then at a point close to the inlet-valve or pump, so that the same hand which manages one may manage the other also. This leaves one hand free to handle the bottles and disk stoppers.

The snifting-passage communicates with a short nozzle 28, Fig. 6, which discharges downward into a second bottle placed below it for that purpose, and to properly center said bottle a bell 29 is attached to the head-stock 49, concentric with said nozzle, so that as the yoke is brought down if the bottle does not stand exactly central as to the nozzle its head will be pushed over by the bell toward its center, so that it will receive the snift from the nozzle 28.

An opening 30 is made in the side of the head-stock 49, immediately at the upper end of the throat-piece 2, through which the disk B may be pushed by the finger. When the plunger descends, it passes by this opening, and as the stopper descends past the ports 17 the small quantity of fluid remaining in the pipe 15 between said ports and inlet-valve under service-pressure will be thrown out and upward through the throat and outward through the opening 30, if the same should be open. To prevent this and cause said expelled water to pass upward into the tube 14 and hood 13, I place a sleeve 31, Fig. 8, around the lower end of the plunger 3 and make the extremities of the plunger-fingers with shoulders 32 to engage the lower end of said sleeve and pull it up when the plunger rises out of the throat 2. A spring 34 serves to keep the

sleeve down upon said shoulders until arrested by contact with the top of the throat-piece 2, when the plunger descends, as shown in Fig. 8. The expelled fluid which is thrown up into the hood 13 is at liberty to escape through a channel 35 behind said sleeve into a duct which communicates with the snift-nozzle, so that all the waste fluid is saved, and at the same time splashing from the opening 30 is prevented.

The snift-valve is held to its seat by means of a spring 36, which bears upon the lever 27, and the tension of said spring may be changed at will by a screw, so that the pressure on the valve 25 shall exceed the service-pressure.

As hereinbefore stated, it is necessary to bring the lower end of the throat-piece down in contact with the bottle, and to prevent breakage of bottles by the sudden contact of metal and glass I employ the cushion 19, protected by a metal plate 20 in the top of the hood 13, and place a similar cushion or rubber ring 37 below the bottle in a recess in the bottling-table and cover it with a metal plate 50, the surface of which is flush with the top of said table. These cushions afford adequate elasticity and prevent cracking the glass when the downward thrust of the plunger is suddenly arrested by contact of the top of the cylinder or head-stock with the interior of the hood.

To facilitate the handling of the bottles, I have made a U-shaped gage 38, the diameter inside being a little greater than the diameter of the bottles which are being filled and the length of the arms being about two of such diameters. The exterior edge of said gage has three notches to engage the same number of pins 39 set in the table, and these pins hold the gage accurately in place and permit its ready removal. When bottles of different sizes are used, as half-pints, pints, or quarts, different gages 38 are used, each being adapted to bottles of a particular size; but the exterior edges which engage the pins 39 may be the same in all. This gage not only centers the bottle under the throat, but also guides the second bottle under the snifting-nozzle.

Bottles of different diameters require corresponding changes in the position of the bell 29 and snifter-nozzle 28. I therefore mount these parts eccentrically on a circular plate 40, which is secured in a corresponding recess and may rotate therein to move said nozzle and bell toward or away from the throat-piece 2.

The throat-piece 2 is made of bronze, with a facing of steel at the lower end for durability, where it comes in contact with the glass of the bottle, and it is made to be readily removable for repairs or replacement with another.

To construct a compact and convenient bottling-machine, I make the base and pillar in one hollow casting of iron 40, having near the bottom a fulcrum-place for the treadle 8,

and at the top two vertical sleeve-guides 41 for the side rods 5. The yoke 6 and spring 7 are therefore inclosed and concealed within said pillar. To make the table adjustable
 5 to accommodate bottles of different heights, I provide a hood 42, the open end of which fits over and slides upon the upper part of the column 40. The closed end constitutes the bottling-table. It is provided with two
 10 holes, through which the guides 41 pass and act as guides for said hood, and with a recess to receive the rubber ring 37 and its protecting-plate 50. The hood 42 is supported upon the upper elbow of the rod 43, which passes
 15 through an adjusting screw-wheel 44, located between two lugs cast on the pillar 40 and having its edge projecting through a slot in the side of said pillar to be accessible to the hand for the adjustment up or down of the
 20 hood 42. A set-screw 45 serves to hold the hood tightly when it has reached the proper height. The shelves 46 serve to hold the empty bottles on one hand and the filled bottles on the other. They are rigidly attached
 25 to the hood and go up or down with it.

Having described my invention, I claim—

1. In a machine for inserting elastic disk stoppers, the tapering throat 2, combined with a collapsible plunger.

30 2. In a machine for inserting elastic disk stoppers, a tapering throat 2, combined with plunger 3, slitted longitudinally to enable it to collapse as it passes through said throat.

3. In a machine for inserting elastic disk stoppers, a tapering throat 2, a collapsible plunger, and a stop to limit the movement of said plunger as to the amount of its protrusion from said throat.

4. Combined with bottle A, provided with
 40 an internal groove 6 in the mouth, which has an inwardly-inclined circular surface for the abutment of the edge of an arched disk stopper, a tapering throat 2, for causing the stopper to assume the arched form, a collapsible plunger, and a stop connected with the same,
 45 whereby when said throat rests upon said bottle the plunger will be arrested when it has entered the bottle the exact distance required to deliver the stopper in said groove.

5. In a machine for inserting disk stoppers,
 50 a tapering throat 2, mounted in a carriage capable of reciprocating in the line of the bottle's axis, a collapsible plunger mounted on a carriage capable of reciprocating in the same plane, a spring to keep said carriages normally separated, and a stop to limit the approach of said carriages to each other.

6. The combination, in a bottling-machine, of a table and operative treadle, the side rods
 60 5, connected with said treadle, the yoke 4, rigidly fastened to said rods, the yoke 9, mounted to slide on said rods, with stops 10 to limit the motion in one direction, a tapering throat 2 in the head-stock 49, attached to yoke 9, and a collapsible plunger 3, attached to yoke
 65 4, substantially as set forth.

7. The combination, in a bottling-machine

for inserting disk stoppers, of a tapering throat-piece 2, adapted to make hard contact with the bottle-top, a plunger to force the stopper through said throat, an elastic cushion-stop 19 to arrest the motion of the plunger without hard shock, and a cushion 37 beneath the bottle.

8. In combination, in a bottling-machine
 75 adapted to fill bottles with effervescing liquids, a tapering throat 2, having inlet-ports 17, a collapsible plunger 3, a cut-off sleeve 31, and a gasket whereby the escape of said liquid is prevented, substantially as described.

9. In combination, in a machine for bottling effervescing liquids, a tapering throat 2, having ports 17, mounted in a head-stock 49, provided with an opening 30, and a tubular sleeve 14, a hood 13, fitted to slide over said
 85 sleeve, a plunger mounted in said hood 13, a cut-off sleeve 31 to close said opening 30, and a gasket 18, made yielding, so as to close around the neck of the bottle while still permitting the throat-piece to make contact with
 90 the bottle, as set forth.

10. In a machine for bottling effervescing liquids, a filling-head having an inlet for the liquid and provided with an elastic gasket adapted to fit the mouth of the bottle, a snift-passage leading from said inlet, a snift-valve
 95 controlling said passage, and a snift-discharge provided with a centering bell or hood, whereby it is adapted to deliver the snift into a second bottle as the first is filled, as and for
 100 the purposes set forth.

11. The combination, with the filling duct and nozzle, of a snift-passage leading therefrom, a valve for controlling the same, and a snift nozzle or discharge adjustable relative
 105 to the first nozzle to accommodate different diameters of bottles, substantially as set forth.

12. The tapered throat-piece 2, provided with a lateral flange near its lower end and made cylindrical externally at its upper end
 110 and provided with ports 17 at its middle, combined with a head-stock 49, having a recess fitted to receive said cylindrical end and said flange and constitute an annular chamber 16 between them, and a liquid-inlet 15,
 115 discharging into said chamber.

13. The combination, with the main bottling-throat, the liquid-ducts, and the plunger, of the snift-valve 25, the passage 23, and nozzle 28, combined with a centering-bell 29, for
 120 the purpose of centering the bottle-mouth as to the nozzle 28.

14. In a bottling-machine, the combination, with the main bottle-filling devices, of the snift-passage 23, nozzle 28, bell 29, and an
 125 eccentric plate 40, whereon said bell is mounted for adjustment by revolution of said plate.

15. In combination with the inlet-pipe 15 and its controlling-valve, the snift-passage
 130 23, snift-valve 25, and the valve-lever 27, extended to a point in immediate proximity with the said controlling-valve of the inlet 15, whereby both of said valves may be oper-

ated by one hand and the other left free to handle the bottles and stoppers, substantially as set forth.

16. In a bottling-machine, the hollow pillar 40, provided with the tubular guides 41 at the top, the guide-rods 5, carrying the yokes 4 and 9 at their top, and the treadle 8 to operate the same, combined with movable hood 42 to constitute a bottling-table adjustable as to height.

17. The hollow pillar 40, provided with tubular guides 41, the rods 5 5, connected at top with the yokes 4 and 9 and at the bottom with the yoke 6, the treadle 8, and retracting-spring 7, combined with the hood 42, adjustable as to height on said pillar.

18. The hollow pillar 40, with guides for the side rods 5 5, the yokes 4 and 9, connected with said rods and carrying the fluid-inlet and stopper-inserting devices, combined with the hood 42 and the adjustable supporting-rod 43, engaging said hood at its center.

19. The combination, in a bottling-machine, of a supporting-pillar 40, a table 42, an operative treadle, and the side rods 5 5, with the yoke 4, rigidly fastened to said rods, the yokes 9, and head-stock 49, mounted to slide on said rods, stops to limit their motion, a tapering throat 2, attached to said head-stock, a collapsible plunger attached to said yoke 4, retracting-springs 12 and 34, and sleeve 31, substantially as set forth.

20. In combination with a bottling-machine adapted to fill bottles with effervescing liquids, a tapering throat 2, having inlet-ports 17, a collapsible plunger 3, and a cut-off sleeve 31, whereby the escape of liquid is prevented.

21. In combination in a machine for bottling effervescing liquids, a tapering throat 2, having ports 17, a head-stock 49, wherein said throat and ports are located, a lateral opening 30 to permit the stoppers to be inserted, a plunger to force the stopper through said throat, and a sleeve 31 to close said stopper-opening against the escape of liquid when said stopper has moved past said ports.

22. In a bottling-machine, the combination, with the main bottle-filling devices, of the snift-passage 23, valve 25, the nozzle 28, and bell 29, adjustable as to distance from the throat 2, substantially as described.

23. In a bottling-machine for effervescing beverages, the bottle-filling mechanism, a waste or snift duct, a controlling-valve for the same, a nozzle for discharging the waste, combined with a holder by said nozzle for maintaining a second bottle in close proximity to the bottle being filled and under said nozzle, whereby the waste is discharged into said second bottle, substantially as set forth.

WILLIAM PAINTER.

Witnesses:

R. D. O. SMITH,
J. B. MCGIRR.