

(19) **DANMARK**

(10) **DK/EP 3494930 T3**



(12)

Oversættelse af
europæisk patentskrift

Patent- og
Varemærkestyrelsen

-
- (51) Int.Cl.: **A 61 F 2/24 (2006.01)**
- (45) Oversættelsen bekendtgjort den: **2020-03-02**
- (80) Dato for Den Europæiske Patentmyndigheds bekendtgørelse om meddelelse af patentet: **2020-01-08**
- (86) Europæisk ansøgning nr.: **18210929.8**
- (86) Europæisk indleveringsdag: **2008-12-15**
- (87) Den europæiske ansøgnings publiceringsdag: **2019-06-12**
- (30) Prioritet: **2007-12-14 US 1400707 P**
- (62) Stamansøgningsnr: **13002630.5**
- (84) Designerede stater: **AT BE BG CH CY CZ DE DK EE ES FI FR GB GR HR HU IE IS IT LI LT LU LV MC MT NL NO PL PT RO SE SI SK TR**
- (73) Patenthaver: **Edwards Lifesciences Corporation, One Edwards Way, Irvine, CA 92614, USA**
- (72) Opfinder: **BENICHOU, Netanel, Edwards Lifesciences, One Edwards Way, Irvine, CA 92614, USA**
- (74) Fuldmægtig i Danmark: **Zacco Denmark A/S, Arne Jacobsens Allé 15, 2300 København S, Danmark**
- (54) Benævnelse: **Bladfastgørelsesramme til en proteseklap**
- (56) Fremdragne publikationer:
WO-A1-03/047468
WO-A2-2005/102015
WO-A2-2006/108090
WO-A2-2009/116041
US-A1- 2002 173 842
US-A1- 2004 186 563

DESCRIPTION

FIELD

[0001] The present disclosure relates generally to an apparatus and method for the restoration of heart valve function. More particularly, the present disclosure concerns embodiments of an implantable prosthetic valve and methods for making the same.

BACKGROUND

[0002] Prosthetic cardiac valves have been used for many years to treat various cardiac valvular disorders. For many years, the definitive treatment was the surgical repair or replacement of a native valve during open heart surgery. More recently, transvascular techniques have been developed, which reduce or eliminate many of the undesirable complications of open heart surgery. Such transvascular techniques traditionally involve the implantation of a prosthetic valve that can be compressed or folded to a reduced diameter. By compressing or folding the prosthetic valve to a reduced diameter, the prosthetic valve can be delivered through a less invasive penetration to a desired target location within the human anatomy. Thereafter, the compressed valve is traditionally released, expanded, separated from the delivery system, and secured to the desired target location.

[0003] US patent application 2004/0186563 discloses a prosthetic aortic valve having a support frame with a continuous, undulating leaflet frame defined therein. The leaflets are attached to the support frame by directly suturing the leaflets at the commissures to respective struts of the support frame.

SUMMARY

[0004] An assembly according to the present invention is defined in claim 1. The assembly comprises a balloon catheter, comprising an inflatable balloon, and a balloon expandable prosthetic aortic heart valve. The heart valve comprises a radially collapsible and expandable annular frame, and a leaflet assembly positioned within the frame. The leaflet assembly comprises a plurality of leaflets that are connected to each other to form commissures of the leaflet assembly. The frame comprises a pair of struts adjacent to each of the commissures, the struts of each pair of struts being spaced apart from each other so as to define an opening therebetween. At each commissure, two adjacent leaflets are positioned between an adjacent pair of struts, with one of the leaflets wrapping around at least a portion of one of the struts and the other leaflet wrapping around at least a portion of the other strut. A cloth portion is attached to a portion of one leaflet that extends radially outside of the frame, the cloth portion being wrapped around one of the struts. Another cloth portion is attached to a portion of the other

leaflet that extends radially outside of the frame, the cloth portion being wrapped around the other strut. Furthermore, the struts are oriented vertically, and the leaflets of the leaflet assembly are attached to the frame without suturing the leaflets at the commissures directly to the frame. Further preferred embodiments of the assembly according to the present invention are provided in claims 2 through 10.

[0005] A method of assembling an implantable balloon-expandable prosthetic valve according to the present invention is defined in claim 11. The method comprises providing a radially collapsible and expandable annular frame. The frame comprises a plurality of circumferentially spaced pairs of vertical struts, the struts of each pair being spaced apart from each other so as to define an opening therebetween. The frame is made of metal selected from a group comprising stainless steel, CoCr alloys and titanium. The method comprises providing a leaflet assembly comprising a plurality of leaflets, inserting a pair of adjacent leaflets through the opening of each pair of vertical struts. The method further comprises wrapping one of the leaflets at least partially around one of the vertical struts and wrapping the other leaflet at least partially around the other vertical strut. The method further comprises securing two cloth portions to each pair of adjacent leaflets by wrapping the additional cloth portions around respective vertical struts and suturing them to the leaflet portions that are radially outside of the frame. Furthermore, the leaflet assembly is attached to the frame without suturing the leaflets at the commissures directly to the vertical struts. Further preferred embodiments of the method according to the present invention are provided in claims 12 through 14.

[0006] A valve prosthesis is provided which is suitable for implantation in body channels or ducts. The valve prosthesis includes an implantable structure having a deployable construction adapted to be initially crimped in a narrow configuration suitable for catheterization through the body ducts to a target location and adapted to be deployed by exerting substantially radial forces (or releasing the valve, if the valve is self-expandable) from within by means of a deployment device to a deployed state at the target location.

[0007] The valve prosthesis desirably includes a two-part foldable frame. The frame is configured to support the flexible leaflets of a unidirectional valve in an optimal manner. The frame has an "upper part" and a "lower part" wherein each part of the frame is shaped with rounded arc portions to support the leaflets. The leaflets are sandwiched between the upper and lower arcs. The frame can have portions, e.g., leaflet receiving portions, that are scalloped shaped to match the shape of the flexible leaflets.

[0008] The length of the arcs is matched to the total length of the cell struts that create the frame. The geometrical constraint on the length of the cell struts is such that the frame can be evenly crimped.

[0009] In one aspect of the invention, a cloth is first assembled (sewn) to the leaflets. The leaflets with the cloth are sandwiched between the two arcs and the cloth is wrapped over the arcs and sewn together. This suture line crosses all the fabric layers of the wrapped over cloth as well as the leaflet to create a robust leaflet attachment.

[0010] In one embodiment, an implantable prosthetic device is provided. The device comprises an upper frame section having a plurality of struts and a first leaflet receiving surface at a lower portion of the upper frame section, a lower frame section having a second leaflet receiving surface at an upper portion of the lower frame section, and at least one flexible leaflet with a first edge portion. The first edge portion is disposed between the first and second leaflet receiving surfaces. In specific implementations, the first and second leaflet receiving surfaces are scalloped shaped.

[0011] In other specific implementations, the device further comprises one or more cloth portions that are attached to the flexible leaflet at or near the first edge portion and wrapped around at least a portion of one or both of the first and second receiving surfaces to secure the flexible leaflet to the upper and lower frame sections. The cloth portions can be attached to the flexible leaflet so that a first excess cloth portion extends away from the first edge portion on an upper side of the flexible leaflet and a second excess cloth portion extends away from the first edge portion on a lower side of the flexible leaflet. The first and second excess cloth portions can be wrapped around the respective first and second leaflet receiving surface and secured to one another. In other specific implementations, the upper frame section and the lower frame section can be connected via one or more struts.

[0012] In other specific implementations, the upper and lower frame sections can be configured to be expanded from a first configuration to a second configuration. The lengths of the first and second leaflet receiving surfaces can be substantially the same in both the first and second configurations. In other specific implementations, the first leaflet receiving surface comprises an arc section. The arc section can be defined as a portion of the leaflet receiving surface that is located between one or more struts that extend away from the first leaflet receiving surface. The length of the arc section can be substantially equal to the combined length of one or more struts on the upper frame section.

[0013] In another embodiment, an implantable prosthetic device comprises a frame comprising a plurality of frame sections. Each frame section can have a lower portion with a scalloped shape. A flexible membrane can comprise a plurality of flexible leaflets, with each flexible leaflet having a lower portion with a scalloped shape. The lower portion of each flexible leaflet can be attached to the lower portion of each frame section.

[0014] In specific implementations, the lower portion of each frame section comprises a first part and a second part, the first and second parts being spaced apart to receive the lower portion of the flexible leaflets in an opening formed therebetween. In other specific implementations, one or more cloth portions are attached to each flexible leaflet, and the cloth portions are wrapped around at least a portion of the first and second parts to secure the flexible leaflets to the frame.

[0015] In other specific implementations, the frame further comprises first and second vertical posts at an upper area between two frame sections. The two vertical posts can be spaced

apart so that they define an opening for receiving a first portion of a first flexible leaflet and a second portion of a second flexible leaflet. Both the first and second portions can be attached to a first and second cloth portion, respectively. The first and second cloth portions can be wrapped around at least a portion of the first and second vertical posts, respectively, to attach the flexible leaflets to the frame. In other specific implementations, a third cloth portion can be positioned radially outside of the frame. The first and second leaflets can be secured to the frame by attaching the first and second cloth portions to the third cloth portion.

[0016] In another embodiment, a method is provided for assembling an implantable prosthetic valve comprising a flexible membrane and crimpable frame with an upper and lower part. The method comprises partially crimping the frame to have a diameter that is less than the diameter of the frame when the valve is expanded to its functional size, positioning an edge of the flexible membrane between the upper and lower part of the frame, and securing the edge of the flexible membrane to both the upper and lower part of the frame.

[0017] In specific implementations, the method further comprises attaching a cloth portion to the edge of the flexible leaflet so that a first excess cloth portion extends away from the edge on an upper side of the flexible membrane and a second excess cloth portion extends away from the edge on a lower side of the flexible membrane. The first excess cloth portion can be wrapped around at least a portion of the upper part of the frame and the second excess cloth portion can be wrapped around at least a portion of the lower part of the frame. The first and second excess cloth portions can be secured to each other at an area radially outside of the frame.

[0018] The foregoing and other objects, features, and advantages of the invention will become more apparent from the following detailed description, which proceeds with reference to the accompanying figures.

BRIEF DESCRIPTION OF THE DRAWINGS

[0019]

FIG. 1 is a perspective view of one embodiment of a prosthetic valve;

FIG. 2 is a schematic illustration of one embodiment of a prosthetic valve mounted to a balloon and deployed within a patient;

FIG. 3 is a flattened view of one embodiment of a frame of a prosthetic valve;

FIG. 4 is a perspective view of one embodiment of a prosthetic valve;

FIG. 5 is a flattened view of one embodiment showing a portion of a frame of a prosthetic valve;

FIG. 6 is a cross-section view taken along line 5-5 in FIG. 5, with a leaflet attachment portion

included;

FIG. 7 is a perspective view of an embodiment of a flexible leaflet with one or more cloth portions sewn to the leaflet;

FIG. 8 is a simplified sectional side view of a portion of the flexible leaflet and cloth shown in FIG. 7;

FIG. 9A is a flattened view of one embodiment showing a portion of a frame of a prosthetic valve;

FIG. 9B is a cross-section view taken along line 9B-9B in FIG. 9A, with two leaflet attachment portions included;

FIG. 10 is a cross-section view showing another embodiment of a portion of a prosthetic valve having two leaflet attachment portions attached to a portion of a frame;

FIG. 11 is an embodiment of another portion of a frames of a prosthetic valve;

FIG. 12 is an embodiment of another portion of a frames of a prosthetic valve;

FIG. 13 is an embodiment of another portion of a frames of a prosthetic valve;

FIG. 14 is a cross-section view taken along line 14-14 in FIG. 11;

FIG. 15 is a view of an embodiment of a frame, with the frame shown in a crimped or partially crimped configuration;

FIG. 16 is a view of the frame shown in FIG. 15 in an expanded (or uncrimped) configuration; and

FIG. 17 is a view of another embodiment of a frame, with the frame shown in a crimped or partially crimped configuration.

DETAILED DESCRIPTION

[0020] The following description is exemplary in nature and is not intended to limit the scope, applicability, or configuration of the invention in any way. Various changes to the described embodiment may be made in the function and arrangement of the elements described herein without departing from the scope of the invention.

[0021] As used in this application and in the claims, the singular forms "a," "an," and "the" include the plural forms unless the context clearly dictates otherwise. Additionally, the term "includes" means "comprises." Further, the term "coupled" generally means electrically, electromagnetically, and/or physically (e.g., mechanically or chemically) coupled or linked and

does not exclude the presence of intermediate elements between the coupled items.

[0022] As used herein, the "expanded" or "deployed" state of a valve assembly or frame refers to the state of the valve assembly/frame when radially expanded to its functional size. The "crimped", "compressed" or "folded" state of a valve assembly or frame refers to the state of the valve assembly/frame when radially compressed or collapsed to a diameter suitable for delivering the valve assembly through a patient's vasculature on a catheter or equivalent mechanism. A valve assembly/frame that is "partially crimped" or "partially compressed" has a diameter that is less than the diameter of the valve assembly/frame in the expanded state and greater than the diameter of the valve assembly/frame in the compressed state.

[0023] Although the operations of exemplary embodiments of the disclosed method may be described in a particular, sequential order for convenient presentation, it should be understood that disclosed embodiments can encompass an order of operations other than the particular, sequential order disclosed. For example, operations described sequentially may in some cases be rearranged or performed concurrently. Further, descriptions and disclosures provided in association with one particular embodiment are not limited to that embodiment, and may be applied to any embodiment disclosed.

[0024] Moreover, for the sake of simplicity, the attached figures may not show the various ways (readily discernable, based on this disclosure, by one of ordinary skill in the art) in which the disclosed system, method, and apparatus can be used in combination with other systems, methods, and apparatuses. Additionally, the description sometimes uses terms such as "produce" and "provide" to describe the disclosed method. These terms are high-level abstractions of the actual operations that can be performed. The actual operations that correspond to these terms can vary depending on the particular implementation and are, based on this disclosure, readily discernible by one of ordinary skill in the art.

[0025] FIG. 1 shows a perspective view of an implantable prosthetic valve 100 (hereinafter "valve 100"), suitable for percutaneous deployment and configured to replace a diseased native valve in a patient. As discussed in more detail below, valve 100 can include a generally cylindrical support frame, such as a stent, which is compressible and/or foldable to a smaller delivery diameter, and a plurality of flexible leaflets releasably attached to the support element.

[0026] The valve 100 in the illustrated embodiment comprises a flexible membrane, or leaflet assembly, 102 mounted on an expandable, annular support stent, or frame, 104. As discussed in more detail below, frame 104 can comprise one or more scalloped portions 166 to which the flexible membrane is attached.

[0027] Valve 100 is desirably adapted to be radially collapsed or compressed to facilitate navigation through the narrow passages of a patient's vasculature to the treatment site within the patient's body. After valve 100 reaches the treatment site (e.g., the aortic valve annulus), valve 100 can be expanded within the orifice. To achieve the radial compression of the valve 100, frame 104 desirably comprises a collapsible and/or compressible support structure.

[0028] Flexible membrane 102 can be attached to frame 104 so that the flexible membrane 102 permits fluid flow through the valve 100 in one direction along a structural axis of the frame 104 and resists fluid flow in the opposite direction. In particular, the implantable structure supports flexible leaflets that allow a forward flow through the valve prosthesis and prevent a reverse flow as the flexible leaflets collapse inwardly to block the reverse flow. To provide for such fluid flow, flexible membrane 102 can comprise a collapsible pliant material formed as flexible leaflets 106 that are arranged to collapse in a tricuspid arrangement. Alternatively, the flexible membrane can be formed into other configurations, including, for example, a mono cusp or bicuspid configuration. Flexible leaflets 106 can comprise three pieces of pliant material that are connected to each other at seams (also referred to as commissure tabs) to form the flexible membrane.

[0029] The flexible membrane 102 can be made from biological matter, such as natural tissue, pericardial tissue (such as bovine, porcine or equine pericardium), a harvested natural valve or other biological tissue. Alternatively, the valve member 102 can be made from biocompatible polymers or similar materials. Various flexible leaflet configurations and materials for constructing such leaflets are described in U.S. Patent No. 6,730, 118, U.S. Patent No. 6,767,362, and U.S. Patent No. 6,908,481.

[0030] As discussed above, frame 104 can comprise, for example, stent that has a generally cylindrical framework that can be expanded at a treatment site to secure valve 100 within or adjacent to the defective valve annulus. Frame 104 can also provide stability to the valve 100 and prevent the valve 100 from migrating after it has been implanted. Frame 104 can be a self-expanding frame or it can be expandable by a balloon member or other mechanical means. Frame 104 can be made from any of various suitable expandable and/or elastic materials and is typically made of a metal, such as stainless steel, CoCr alloys, titanium, or other biocompatible metals. Frame 104 also can be made from self expandable shape memory alloys, such as nickel titanium (NiTi) shape memory alloys, as marketed, for example, under the trade name Nitinol.

[0031] FIG. 2 is a schematic illustration of a flexible membrane 102 coupled to a frame 104 that is mounted on an inflatable balloon 110 of a balloon catheter for delivery and deployment of valve 100. Valve 100 can be initially crimped to a smaller radial profile on balloon 110 so that it presents a narrower cross-sectional profile to facilitate percutaneous delivery of the valve 100 to the treatment site. FIG. 2 illustrates the valve 100 being deployed in the aorta A at the aortic annulus 116 to replace a diseased or damaged native aortic valve. However, it should be understood that the prosthetic valves described herein can be implanted in other channels or orifices in the body using the same techniques as the one used for the implantation of the aortic valve prosthesis. Such an implantation may, for example, include the implantation of: valves in the veins (for instance a cardiac valve), valves in the esophagus and/or at the stomach, valves in the ureter and/or the vesica, valves in the biliary passages, valves in the lymphatic system, and valves in the intestines.

[0032] In one embodiment, a delivery catheter can advance valve 100 (mounted on balloon 110) through an introducer sheath and into the vasculature of a patient. The delivery catheter can then be advanced over a guidewire to move valve 100 to a target location in a body duct, such as the aortic annulus 116 of aorta A (FIG. 2). After the valve 100 is properly positioned at the treatment site, balloon 110 can be inflated to expand frame 104 radially to the desired size, securing valve 100 at the treatment site. It should be understood that valve 100 can also be deployed using a non-inflatable, mechanical embodiment of the delivery catheter or, alternatively, valve 100 can be a self-expanding valve.

[0033] In one embodiment, frame 104 can comprise one or more scalloped portions 166 at a lower portion of frame 104. FIG. 3 illustrates, for convenience, a flattened schematic view of a frame 104 that comprises a plurality of frame sections 150, 152, 154, which each have a respective scalloped portion 166 at a lower portion of frame 104. Frame sections 150, 152, 154 can comprise a plurality of struts (or strut sections) 160, 210. Adjacent scalloped portions 166 can be connected together by struts 160. Because the frame is shown in a flattened view, the two end strut sections 160 of FIG. 3 appear to be disconnected; however, the two end strut sections 160 are desirably connected to one another, in the same manner of the other strut sections 160 shown in FIG. 3.

[0034] Referring again to FIG. 1, if desired, an expansion restriction member 162 can be secured between two adjacent strut sections 160. Expansion restriction member 162 can be, for example, a suture or thread that is secured to adjacent strut sections 160 to prevent the valve 100 from being over-expanded during deployment.

[0035] FIG. 4 illustrates a valve 100 with a frame 104 that has a plurality of scalloped portions 166. Frame 104 comprises a collapsible frame with a flexible membrane 102 attached thereto. As noted above, strut sections 160 desirably extend from a portion of the scalloped frame to provide structural strength to the frame 104. The number of strut sections 160 between adjacent scalloped portions 166 can vary. For example, FIG. 3 shows two strut sections 160 (forming one cell) between adjacent scalloped portions 166, while FIG. 4 shows four strut sections 160 between adjacent scalloped portions 166 (arranged to form three cells between adjacent scalloped portions). Strut sections 160 can also extend radially outward from the frame 104, as shown in FIG. 4, to help anchor the valve 100 in the body and to help prevent migration or movement of the valve after it has been deployed within the body. Other portions of the frame 104 can also be configured to extend radially outward to help anchor the valve in place. For example, certain cell struts, such as cell struts 270 (FIG. 4), can be configured to extend radially outwards from the frame 104 to provide additional valve anchoring means.

[0036] As best shown in FIG. 5, a frame 104 can be comprised of a first or "upper" part 202 and a second or "lower" part 204. First part 202 can include a plurality of struts or strut sections 210 and a first arc section 206. Second part 204 includes a second arc section 208. Both arc sections 206, 208 desirably have an arc length 280 that is substantially the same. First part 202 and second part 204 are desirably separate elements that are not connected to each other by any strut members of the frame 104. Accordingly, as shown in FIG. 5, when first

part 202 is positioned adjacent second part 204, a gap (or opening) 282 is defined between the two parts. A flexible membrane 102 or portions thereof can be received into gap 282 to facilitate attachment of the flexible membrane 102 to the frame 104. The two surfaces facing gap 282 include a first leaflet receiving surface (e.g., the lower surface of upper part 202) and a second leaflet receiving surface (e.g., the upper surface of lower part 204). If desired, the first part 202 and second part 204 can be connected via one or more connecting struts 268 (FIG. 17) to provide additional structural strength to the frame 104.

[0037] In one embodiment, the flexible leaflets 106 of the flexible membrane 102 can be received in the gap 282 and the first and second arc sections 206 and 208 can help secure the flexible leaflets to the frame 104 and/or provide a point of attachment. Referring to FIGS. 7 and 8, a cloth member 304 is desirably attached to a flexible leaflet 106. FIG. 7 is a perspective view of a leaflet sub-assembly 302 in which one or more portions of cloth 304 are attached to selected portions of flexible leaflet 106. Leaflet sub-assembly 302 can be formed by attaching cloth 304 to flexible leaflet 106 by sewing (suturing) or other suitable attachment means. The cloth 304 can be any fabric or other material made from any of various suitable biocompatible synthetic materials, such as woven polyester, polyethylene terephthalate (PET), or polytetrafluoroethylene (PTFE).

[0038] To attach cloth 304 to the leaflet 106, a cloth portion 304 can be folded over a lower edge portion 308 (FIG. 8) of leaflet 106, and cloth 304 and leaflet 106 can be sewn together along a leaflet-cloth suture line 330 (hereinafter "suture line 330"). In this manner, leaflet edge 308 is captured between two layers of cloth 304 to form a leaflet attachment portion 314 (FIG. 6). Excess portions 310 of cloth 304 extend along both sides of flexible leaflet 106 away from suture line 330 and away from edge 308. As described in more detail below, excess cloth portions 310 can be used to secure the flexible leaflets 106 to the frame 104. If desired, a plurality of separate cloth portions 304 (as shown in FIG. 7) can be attached to the leaflet 106. In this manner, when the leaflet is secured to the frame between the first and second arc sections 206, 208, the separate cloth portions 304 can extend between the struts that extend from the first arc section 206.

[0039] Referring now to FIG. 6, a method of attaching leaflet sub-assembly 302 to frame 104 is described. FIG. 6 is a simplified cross-sectional view of a leaflet sub-assembly attached to a frame. In particular, leaflet sub-assembly 302 extends radially between and is "sandwiched" or otherwise captured between first arc section 206 (of the first part 202 of the frame) and second arc section 208 (of the second part 204 of the frame). As shown in FIG. 6, leaflet sub-assembly 302 can be positioned between the two arc sections so that suture-line 330 is substantially captured between the two arcs. Additionally, an edge portion 314 comprised of two layers of cloth and a portion of the leaflet desirably extends radially outwards from between the first and second arc sections 206 and 208.

[0040] As illustrated in FIG. 6, excess cloth portions 310 of cloth 304 can be wrapped over and around first arc section 206 and second arc section 208. In this embodiment, excess portions 310 of cloth 304 can be sewn together within an attachment area 316. Attachment area 316 is

desirably located outside of (e.g., radially external to) frame 104. For example, a sandwiching suture line 320 can pass through the two ends of excess cloth portions 310 and also through the edge portion 314 that extends out from between first and second arc sections 206 and 208. Thus, by securing the flexible leaflet to the cloth and then securing portions of the cloth to itself, the flexible leaflet 106 can be securely attached to the frame 104 without requiring additional sutures passing through the flexible leaflet 106. If desired, leaflet 106 can be positioned so that suture line 320 passes through the excess cloth portions 310 and through the leaflet 106.

[0041] Conventional frames typically require suturing the flexible membranes at the commissures directly to vertical posts. However, the suture line applies local stress and abrasion on the leaflet which may lead to early leaflet failure. Accordingly, this approach causes very high stresses on the commissures when the flexible leaflets move between open and closed positions.

[0042] FIGS. 9A and 9B illustrate a method of attaching flexible leaflets to a frame without suturing the flexible valves directly to vertical posts. FIG. 9A illustrates an upper portion 402 of frame 104 where two leaflets come together in the valve (e.g., the commissure). At the commissure, first frame part 202 has a first vertical strut 404 and a second vertical strut 406. First strut 404 and second strut 406 are spaced apart and define an opening 420 therebetween for receiving at least a portion of two adjacent flexible leaflets 106.

[0043] FIG. 9B is a cross-section view taken along line 9B-9B in FIG. 9A, with flexible leaflets and cloth portions shown positioned between the first and second struts 404, 406. As shown in FIG. 9B, two flexible leaflets 106a and 106b can be inserted and captured between first and second struts 404 and 406. Flexible leaflet 106a, 106b can be attached to a respective cloth 304, creating an area 408 where the leaflet 106a is attached to the cloth 304 and an area where the leaflet 106a is not attached to the cloth 304. Leaflet 106a can be wrapped around at least a portion of first strut 404 so that the unattached portion of the leaflet 106a extends radially inwards into the interior of the frame. The unattached portion of cloth 304 can form an excess cloth portion 430 that extends radially inward into the frame and wraps back around the strut 404.

[0044] Similarly, leaflet 106b can be attached to a cloth 304, creating an area 410 where the leaflet 106b is attached to the cloth 304 and an area where the leaflet 106b is not attached to the cloth 304. Leaflet 106b can be wrapped around second strut 406 so that the unattached portion of the leaflet 106b extends radially inwards into the interior of the frame. The unattached portion of cloth 304 can form an excess cloth portion 432 that extends inward into the frame and wraps back around the strut 406.

[0045] To secure the leaflets 106a, 106b to the frame, another piece of cloth 440 can be placed radially outside of the frame and positioned over the portion of flexible leaflets 106a, 106b that extend radially outside of the frame (e.g., the portions of 408, 410 that are external to struts 404, 406). The second piece of cloth 440 can be sewn to the leaflet 106a at an

attachment area 350 to secure the leaflets to first strut 404. Thus, the second piece of cloth 440 can be sewn (or otherwise attached) to leaflet 106a, the portion of cloth 304 attached to leaflet 106a, and to the excess cloth portion 430 that has been wrapped around first strut 404. The second piece of cloth 440 can similarly be sewn to the leaflet 106b, the portion of cloth 304 attached to leaflet 106b, and to the excess cloth portion 432 (which has been wrapped around second strut 406) at an attachment area 360 to secure the leaflets to second strut 406.

[0046] Operationally, when flexible leaflets 106 are closed, load F is applied to the leaflets to move them radially inward as shown in FIG. 9B. Folding flexible leaflets 106 around stent struts 404 and 406 can reduce stresses on the leaflets by creating a friction attachment at leaflet-strut contact areas 412, which reduces the stresses at suture lines 340. Furthermore, as discussed in more detail below, by securing the leaflets 106a, 106b at attachment areas 350, 360 on the outer side of frame 104, relative movement at the leaflet/frame interface can be reduced or eliminated, which further reduces stresses and strains on the leaflets during expansion and/or compression of the valve 100.

[0047] FIG. 10 shows another embodiment by which flexible leaflets 106c, 106d can be attached to first and second struts 404 and 406 of a frame 104. Similar to the embodiment shown in FIG. 9B and described above, a first leaflet 106c is secured to a cloth 304 by a suture 460 and an excess cloth portion 462 extends inwardly of the frame and wraps back around first strut 404 to extend back outwardly of the frame. A second leaflet 106d is secured to a cloth 304 by a suture 464 and an excess cloth portion 466 extends inwardly of the frame and wraps back around second strut 406 to extend back outwardly of the frame. After the excess portions of cloth 462, 466 are wrapped back around first and second struts 404, 406, they can be secured to one another by another suture 468 at an area outside of the frame 104. As shown in FIG. 10, suture 468 can pass through both of the excess cloth portions 462, 466 and through portions of the leaflets (e.g., leaflet portions 470, 472) that extend outward from between the first and second struts 404, 406. In addition, if desired, the excess cloth portions and/or flexible leaflets can be folded and/or wrapped around each other so that the suture 468 extends through one or more portions of the excess cloth portions and/or the flexible leaflets.

[0048] FIGS. 11-13 show additional embodiments of frames 104 that have scalloped portions. In particular, FIGS. 11-13 illustrate alternative shapes and configurations of struts 210, 270. The shape and number of struts can vary. For example, struts 210 can be configured to be substantially straight (FIG. 13), or they can be rounded or curved (FIG. 12).

[0049] As described above with regard to FIG. 4, the struts or other frame members can also be configured to extend radially outward of the generally cylindrical surface of the expandable framework to improve the ability to anchor the frame to the tissue. For example, as best seen in FIGS. 4, 11, and 14, struts 160 and/or 270 may be bent so that they protrude outward from stent struts 210 (i.e., radially outward from the tangential plane P defined on an external surface of the cylindrically shaped frame 104). Similarly, in the embodiments illustrated in FIGS. 12 and 13, struts 160 and/or 270 can be formed so that one or more of struts 160 and/or 270 extend radially outward from the frame 104.

[0050] The use of the scalloped frame 104 together with the methods of attachment described herein beneficially enable the flexible membrane and flexible leaflets to be secured to a frame without introducing needle holes and/or sutures in the area where a leaflet flexes (e.g., leaflet flexing area 318 shown in FIG. 6) or undergoes significant stresses. Leaflets are particularly susceptible to failure at areas where they flex and by reducing and/or eliminating needle holes in the leaflets at these areas, the structural integrity of the flexible leaflets can be improved. Thus, in contrast to traditional methods of attachment where a flexible membrane is simply sutured to a frame, the methods of attachment described herein eliminate and/or reduce needle holes and sutures in the leaflet flexing area 318, which increases the durability of the valve.

[0051] In addition, the leaflet can be attached to the frame along the length of the first and second arc sections 206 and 208. By capturing the entire edge 308 (or substantially the entire edge) of flexible leaflet 106 between the arc sections 206 and 208 and securing the leaflet to the arc sections as described herein, the leaflet stresses can be optimally distributed along the length of the leaflet edge.

[0052] In addition, the methods described herein are particularly useful to facilitate attaching a flexible membrane to a frame while the valve is in a partially collapsed (partially-crimped) configuration. As described in U.S. Patent Publication 2008/0154355, it can be desirable to attach a flexible membrane to a partially collapsed frame, which can allow the frame to be constructed with relatively large angles between adjacent struts to enhance the structural rigidity of the frame. Due to the enhanced structural rigidity, the frame can be constructed with thinner metal struts, which can allow the frame to be crimped to a smaller profile. However, it can be difficult to attach a flexible membrane to a frame in a partially collapsed state because the diameter of the flexible membrane is greater than the diameter of the partially collapsed frame. For instance, in certain implementations, the diameter of the valve member can be twice that of the partially collapsed frame. The valve member therefore cannot easily conform to the shape of the partially collapsed frame, and as a result, assembly of the valve assembly is rendered more difficult.

[0053] The frames described herein can easily and accurately receive flexible membranes while the frames are in a partially collapsed configuration. In addition, by reducing the relative movement that occurs between the frame and the flexible leaflets during expansion of the valve at the treatment site, the valves produced by the methods describe herein have increased strength and durability.

[0054] Referring again to FIG. 5, first and second arc sections 206 and 208 are substantially the same length (e.g., arc length 280). The length of the first and second arc sections 206, 208 desirably can be selected to correspond to the length of a similarly scalloped shaped edge portion of a leaflet. Thus, as described herein, the accurate assembly of the scalloped-shaped leaflet 106 between the two arc sections 206, 208 can be achieved. In addition, the attachment of the leaflet 106 to the arc sections 206, 208 can be easily and accurately performed even if

the frame 104 is in a crimped (folded) or partially crimped configuration due to the fact that the arc length of sections 206, 208 where the leaflet is attached remains constant when the frame is compressed.

[0055] FIGS. 15 and 16 illustrate a segment of a frame that is configured to expand from a reduced profile (FIG. 15) to an expanded profile (FIG. 16) while maintaining the relationship between first and second arc sections 206, 208. In particular, the length of corresponding portions of first and second arc sections 206, 208 are desirably matched to the lengths of related struts SL1, SL2, and SL3. For example, as shown in FIGS. 15 and 16, arc section 500 can be defined by the length of arc section 206 between two strut members extending therefrom (e.g., SL1 and SL3). Arc section 500 can be configured to have substantially the same length as the combined length of one or more struts. In particular, Arc section 500 is configured to be substantially the same length as the combined length of struts SL2 and SL3.

[0056] After flexible leaflets are attached to the frame, the frame can expand smoothly and evenly from a reduced profile (FIG. 15) to an expanded profile (FIG. 16), causing arc sections 206, 208 to also expand evenly. This even expansion from a first profile to a second profile reduces relative movement between the arc sections, which, in turn, reduces stress on the leaflets that are attached to the arc sections. Moreover, because the length of the struts are matched to corresponding lengths of sections of the first and second arc sections 206, 208, relative movement between the frame and flexible leaflets is reduced in all configurations and stages of crimping and/or expansion. Thus, a flexible leaflet can be attached to the frame shown in FIG. 15 and then, if desired, the frame can be crimped (or folded) to an even smaller profile without causing additional stresses at the leaflet attachment area.

[0057] In prior art implantable valve devices, during deployment, the dimensions of the complete, implantable structure of the implantable valve vary from its initial first crimped position to its final deployed position. Thus, typically when attaching flexible leaflets to the implantable structure one should take into consideration the dimension changes and leave "slack" or extra leaflet material so that upon deployment of the valve device the flexible leaflets do not tear or deform. By maintaining a constant arc length of the arc sections during deployment of valve 100, there is no need for "slack" material in the flexible leaflets 106. Instead, the attachment points of the flexible leaflets 106 remain at a constant distance regardless of the delivery position of valve 100 (crimped or expanded).

[0058] Referring to FIG. 17, another embodiment of a frame 104 is disclosed. FIG. 17 shows a section of a compressed frame that comprises first arc section 206 and second arc section 208, with the two arc sections being connected via optional connecting struts 268. As described above with regard to FIGS. 15 and 16, relative movement between the first and second arc sections 206, 208 can be avoided by matching arc sections with strut sections so that the first arc section 206 and second arc section 208 remain constant during deployment, providing a stable area for anchoring flexible leaflets 106. As shown in FIG. 17, in this embodiment, the arc length of arc section 510 is matched to the total length SL of cell struts SL1, SL2, and SL3. That is, the total length SL (SL1 + SL2 + SL3) of the strut sections is

substantially the same as the length of arc section 510. Because the geometrical constraint on length SL of cell struts 210 is designed such that cell struts 210 may be collapsed and expanded without changing the dimensions of the first and second arc sections 206 and 208, the frame 104 can be evenly crimped and/or expanded, which allows flexible leaflets 106 to also deploy evenly.

[0059] In embodiments disclosed above, little or no relative movement exists between the flexible leaflets 106 and attachment points on the first and second arc sections 206 and 208. As a result, the valve has greater durability and is capable of withstanding the harsh conditions prevailing within the vasculature and especially the millions of cycles of stress applied by the blood pressure.

[0060] In view of the many possible embodiments to which the principles of the disclosed invention may be applied, it should be recognized that the illustrated embodiments are only preferred examples of the invention and should not be taken as limiting the scope of the invention. Rather, the scope of the invention is defined by the following claims. We therefore claim as our invention all that comes within the scope of these claims.

REFERENCES CITED IN THE DESCRIPTION

This list of references cited by the applicant is for the reader's convenience only. It does not form part of the European patent document. Even though great care has been taken in compiling the references, errors or omissions cannot be excluded and the EPO disclaims all liability in this regard.

Patent documents cited in the description

- [US20040186563A \[0003\]](#)
- [US6730A \[0029\]](#)
- [US118A \[0029\]](#)
- [US6767362B \[0029\]](#)
- [US6908481B \[0029\]](#)
- [US20080154355A \[0052\]](#)

Patentkrav

1. Anordning omfattende:

- 5 et ballonkateter, der omfatter en oppustelig ballon (110); og
en ballonudvidelig aortahjerteklapprotese (100), omfattende:
en radialt sammenklappelig og udvidelig ringformet ramme (104);
en bladanordning (102), der er anbragt inden i rammen (104), hvor bladanord-
ningen omfatter en flerhed af blade (106), der er forbundet med hinanden for
at danne kommissurer af bladanordningen (102);
10 hvor rammen (104) omfatter et par stivere (404, 406), der er naboliggende til
hver af kommissurerne, idet stiverne af hvert par er anbragt med afstand fra
hinanden for således at definere en åbning (420) derimellem;
hvor ved hver kommissur to naboliggende blade (106a, 106b) er anbragt mel-
lem et naboliggende par stivere (404, 406), idet et af bladene (106a) omvikles
15 omkring mindst en del af en af stiverne (404), og det andet blad (106b) omvik-
les omkring mindst en del af den anden stiver (406);
hvor en klædedel (304) er fastgjort til en del (408, 410) af et blad (106a, 106b),
der strækker sig radialt uden for rammen, idet klædedelen (304) omvikles om-
kring en af stiverne (404, 406), og
20 hvor en anden klædedel (304) er fastgjort til en del (408, 410) af det andet blad
(106a, 106b), der strækker sig radialt uden for rammen, idet klædedelen (304)
omvikles omkring den anden stiver (404, 406),
kendetegnet ved, at stiverne (404, 406) er orienteret vertikalt, og at bladene
(106a, 106b) af bladanordningen (102) er fastgjort til rammen (104) uden at sy
25 bladene (106a, 106b) ved kommissurerne direkte på stiverne (404, 406).

2. Anordning ifølge krav 1, hvor hvert blad (106) har en nedre kantdel, som har
en rundtakket form og er fastgjort til rammen (104).

- 30 3. Anordning ifølge krav 2, hvor klædedelene (304) er syet til modsatte over-
flader af den nedre kantdel af hvert blad (106).

4. Anordning ifølge et af de foregående krav, hvor klædedelene (304) af hver
kommissur omfatter en fastgjort del, som er fastgjort til et af bladene (106a,

106b), og en overskydende klædedel (430, 432), der strækker sig indad i rammen og omvikles tilbage omkring en af de vertikale stivere (404, 406).

5 **5.** Anordning ifølge et af de foregående krav, hvor de vertikale stivere (404, 406) af hvert par er forbundet til hinanden ved deres øvre ender.

6. Anordning ifølge et af de foregående krav, hvor parrene af vertikale stivere (404, 406) befinder sig ved rammens (104) øvre ende.

10 **7.** Anordning ifølge et af de foregående krav, hvor hvert par af vertikale stivere (404, 406) er forbundet til naboliggende par af vertikale stænger af en række af vinklede stivere, der strækker sig periferisk.

15 **8.** Anordning ifølge et af de foregående krav, hvor:
rammen (104) omfatter et øvre rammeafsnit og et nedre rammeafsnit, hvor det øvre rammeafsnit har en flerhed af stivere og en første bladmodtagende overflade ved en nedre del af det øvre rammeafsnit, det nedre rammeafsnit har et anden bladmodtagende overflade ved en øvre del af det nedre rammeafsnit; hvert blad omfatter en nedre kantdel, der er anbragt mellem den første og den anden bladmodtagende overflade.
20

9. Anordning ifølge krav 8, hvor den første og den anden bladmodtagende overflade har en rundtakket form.

25 **10.** Anordning ifølge et af de foregående krav, hvor et andet stykke klæde (440) er placeret radialt uden for rammen (104) og er anbragt over delen med fleksible blade (106a, 106b), der strækker sig radialt uden for rammen (104).

30 **11.** Fremgangsmåde til at samle en implanterbar ballonudvidelig proteseklap omfattende:

at tilvejebringe en radialt sammenklappelig og udvidelig ringformet ramme (104), hvor rammen omfatter en flerhed af periferisk par af vertikale stivere (404, 406) anbragt med afstand, hvor stiverne i hvert par er anbragt med afstand fra hinanden for således at definere en åbning (420) derimellem, hvor
35 rammen (104) er lavet af et metal udvalgt fra en gruppe bestående rustfrit stål, CoCr-legeringer og titan;

at tilvejebringe en bladanordning (102), der omfatter en flerhed af blade (106);
at indføre et par naboliggende blade (106a, 106b) gennem åbningen (420) af
hvert par vertikale stivere (404, 406);

5 at omvikle et af bladene (106a, 106b) i det mindste delvist omkring en af de
vertikale stivere (404, 406) og at omvikle det andet blad (106a, 106b) i det
mindste delvist omkring den anden vertikale stiver (404, 406); og

10 at fastgøre to klædedele (304) til hvert par af naboliggende blade (106a, 106b)
ved at omvikle de yderligere klædedele (304) omkring de respektive vertikale
stivere (404, 406) og sy dem til bladdelene (408, 410), som er radialt uden for
rammen,

kendetegnet ved, at bladanordningen (102) er fastgjort til rammen (104) uden
at sy bladene (106a, 106b) ved kommissurerne direkte på de vertikale stivere
(404, 406).

15 **12.** Fremgangsmåde ifølge krav 11, hvor klædedelene (304) yderligere sys til
de modsatte overflader af en nedre kantdel med rundtakket form af hvert blad.

20 **13.** Fremgangsmåde ifølge krav 11 eller 12, yderligere omfattende at fastgøre
den nedre kantdel af hvert blad til rammen efter syning af klædedelene (304)
til bladene.

25 **14.** Fremgangsmåde ifølge et af kravene 11 til 13, hvor hver klædedel (304)
omfatter en fastgjort del, som er fastgjort til et af bladene (106a, 106b), og en
overskydende klædedel (430, 432), der strækker sig indad i rammen og om-
vikles tilbage omkring en af de vertikale stivere (404, 406), hvor de fastgjorte
dele og de overskydende klædedele (430, 432) er syet til bladdelene (408,
410), som er radialt uden for rammen og til klædedelen (440).

DRAWINGS

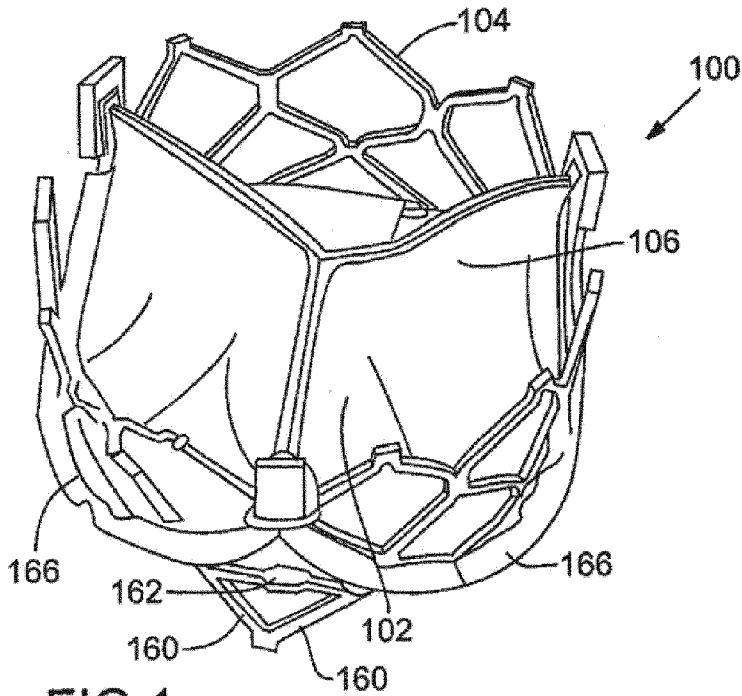

FIG. 1

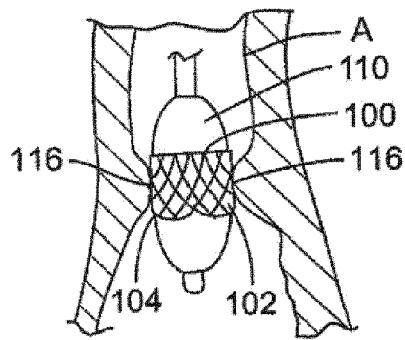

FIG. 2

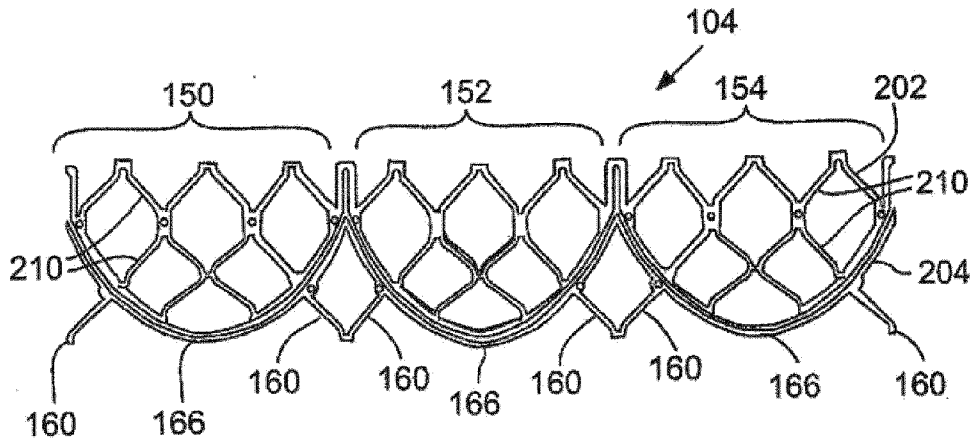

FIG. 3

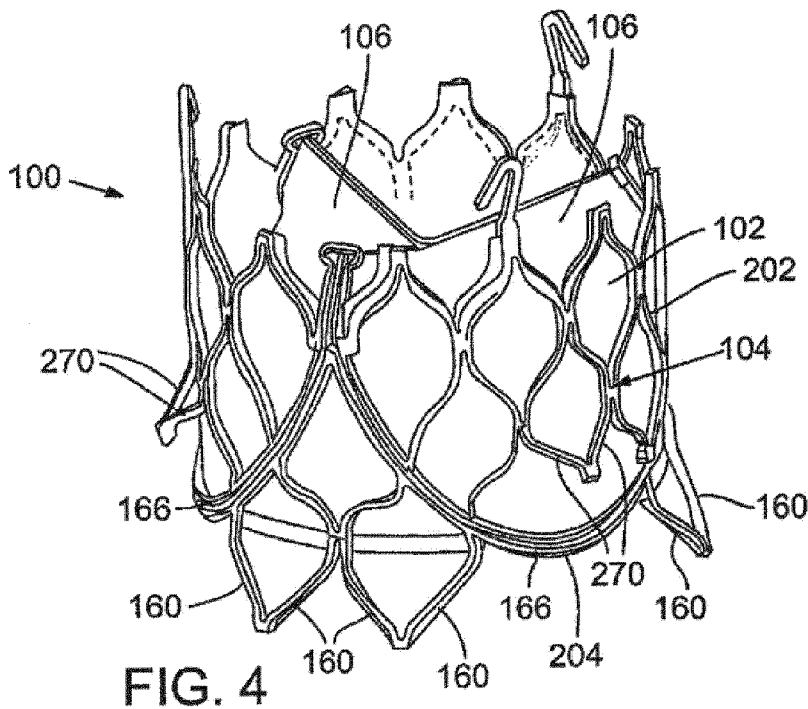
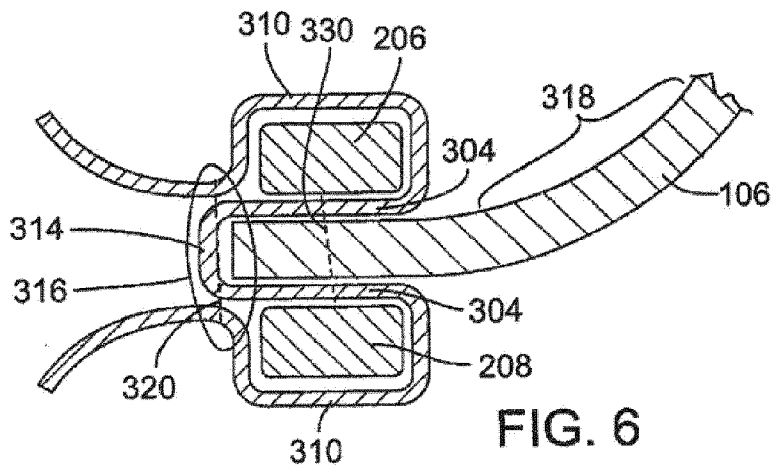
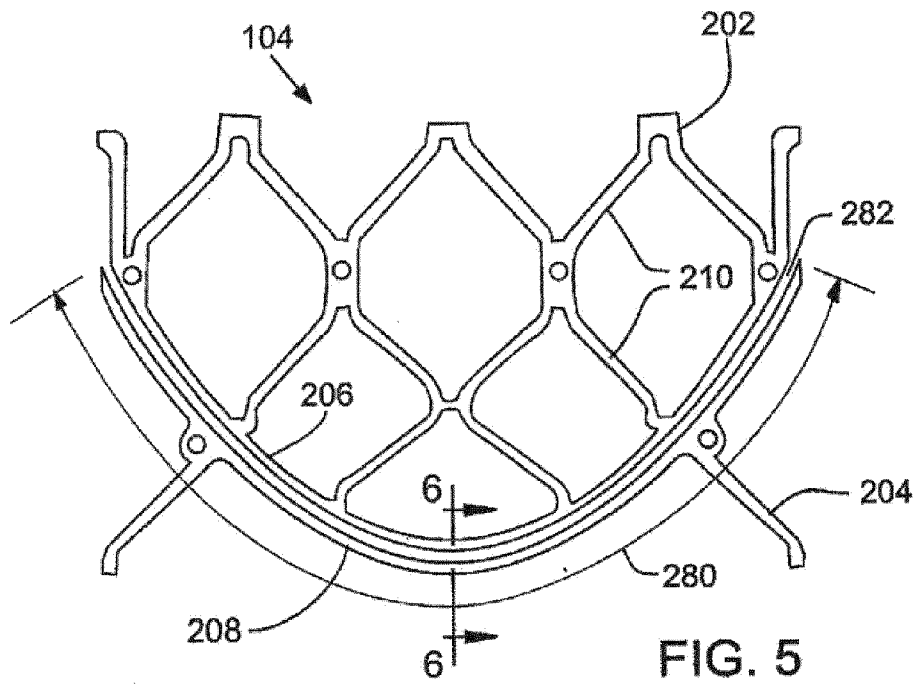
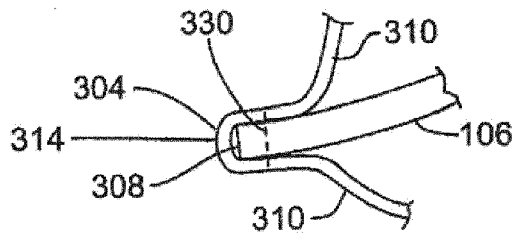
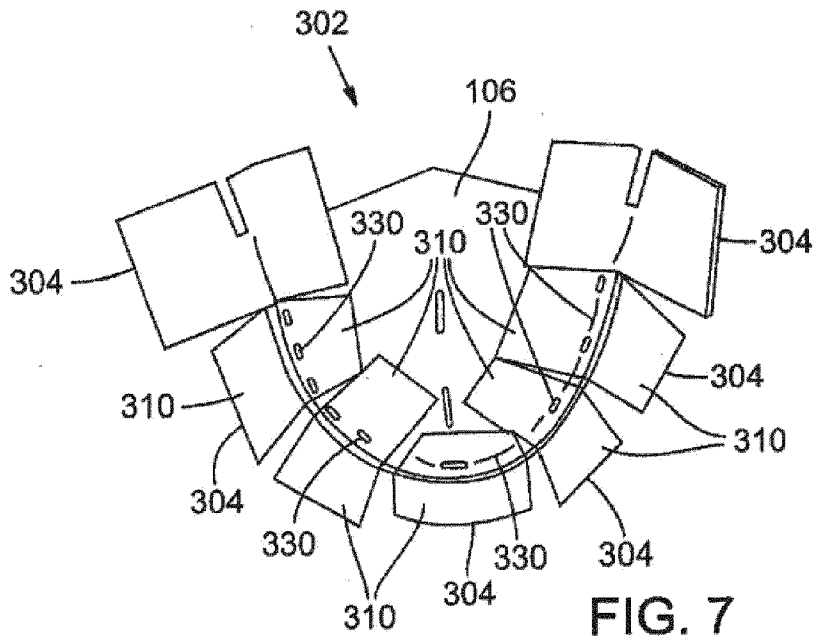
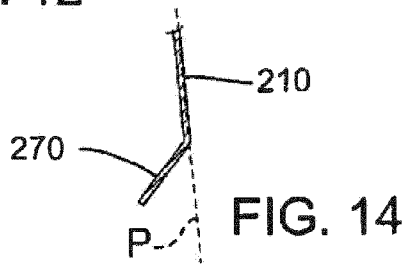
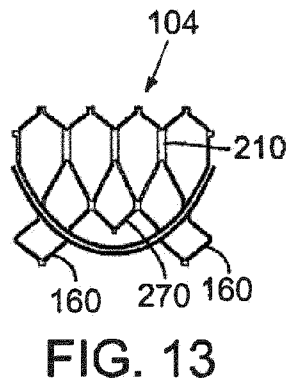
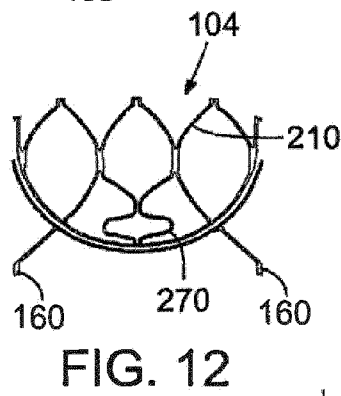
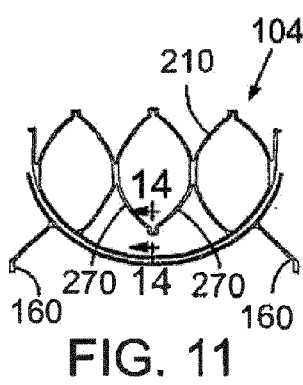
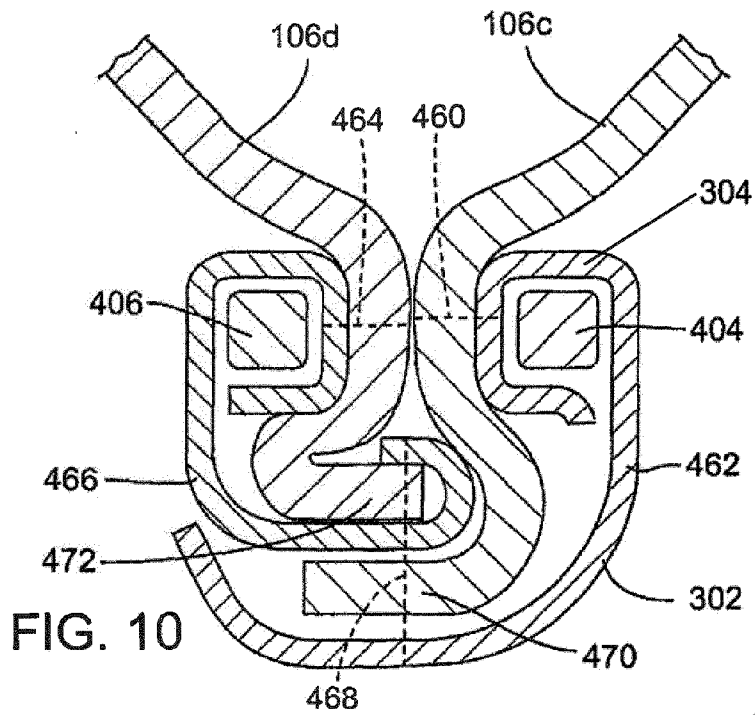
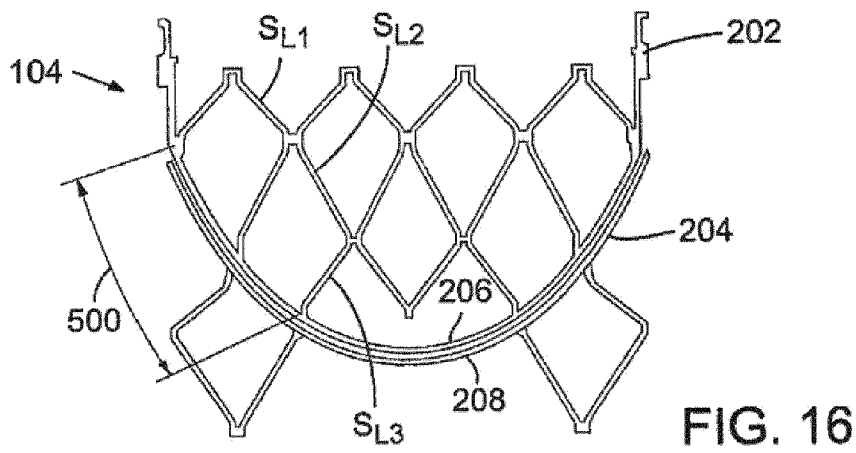
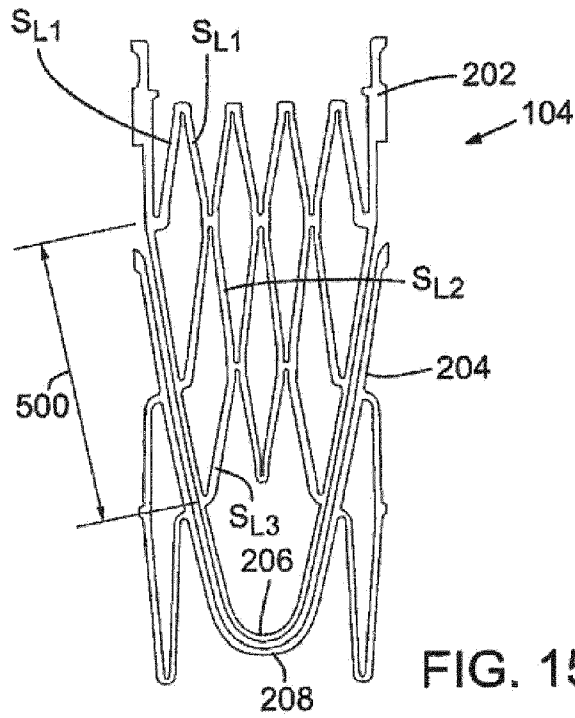

FIG. 4









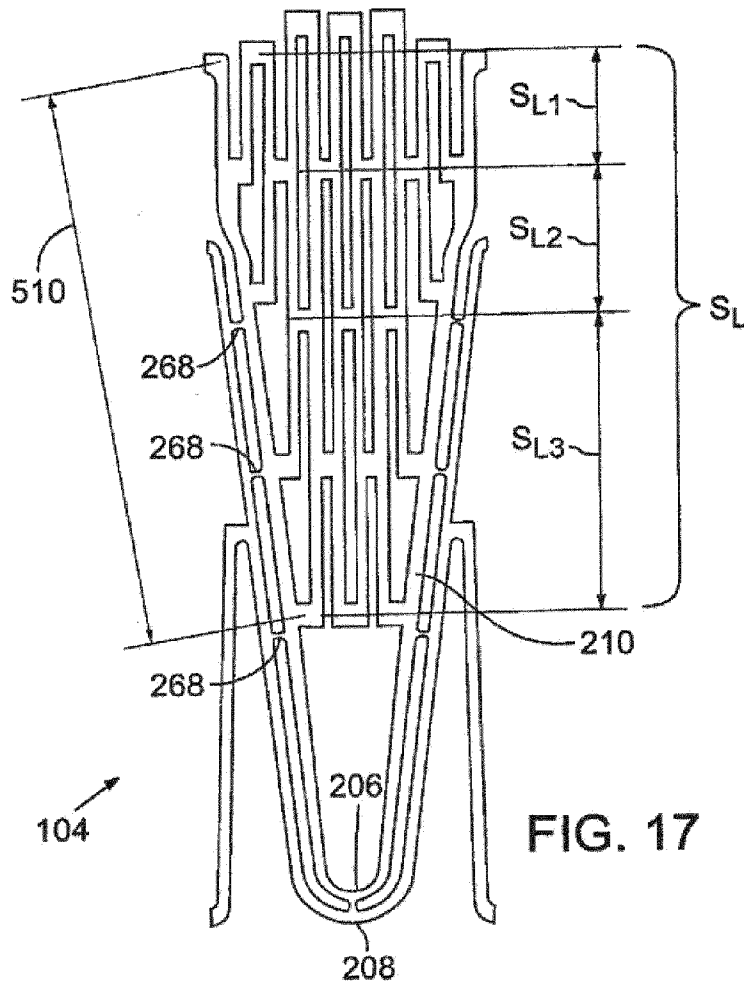

FIG. 17