

A. G. HAWKES.

Improvement in Elevators.

No. 129,339.

Patented July 16, 1872.

Fig. 1

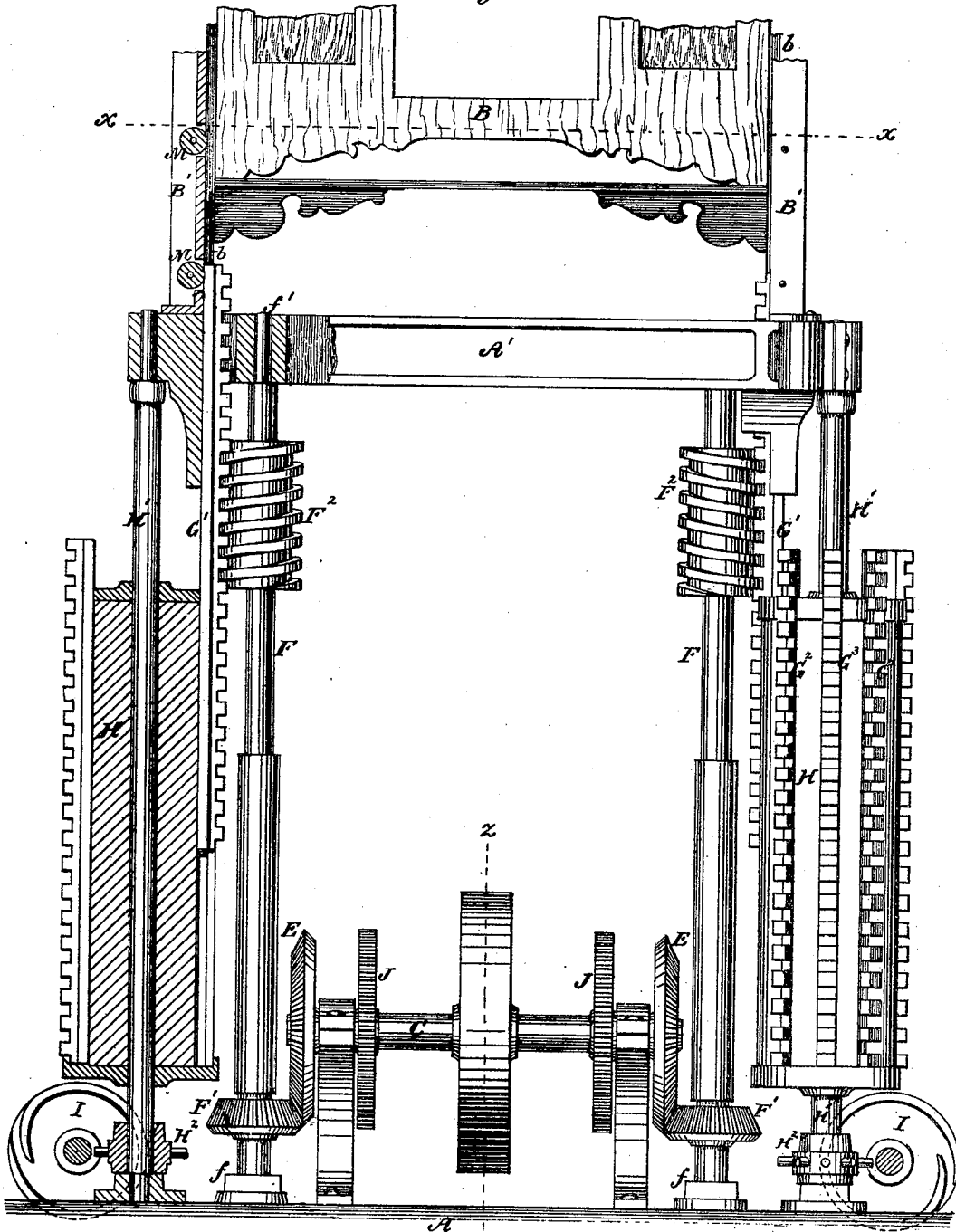

Witnesses:-

Thomas C. Smith
J. R. Nottingham

Albert G. Hawkes
by his attys
Dunn & Rome

A. G. HAWKES.
Improvement in Elevators.

No. 129,339.

Patented July 16, 1872.

Fig. 2

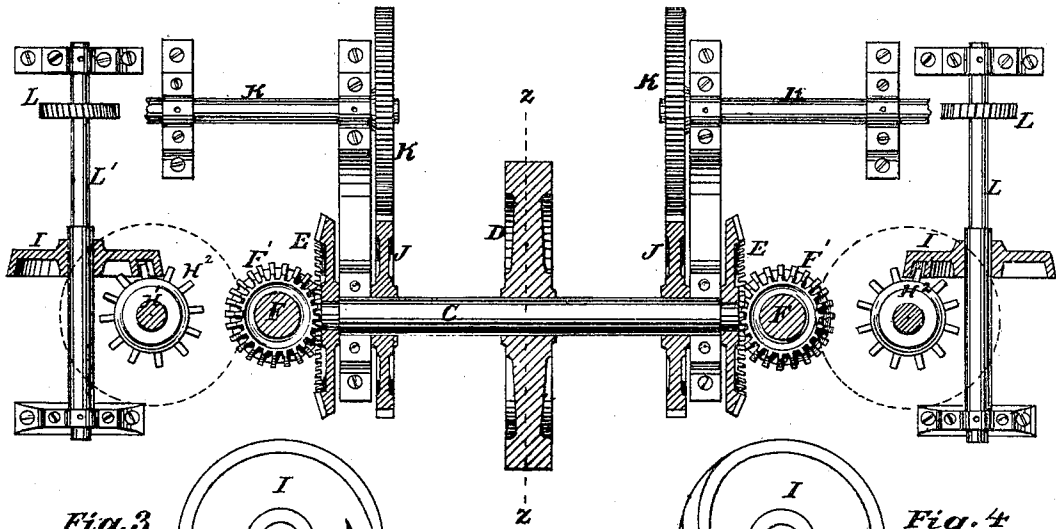

Fig. 3

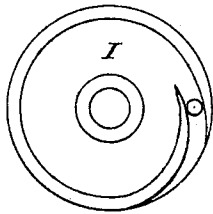

Fig. 4

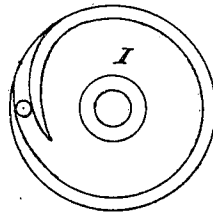
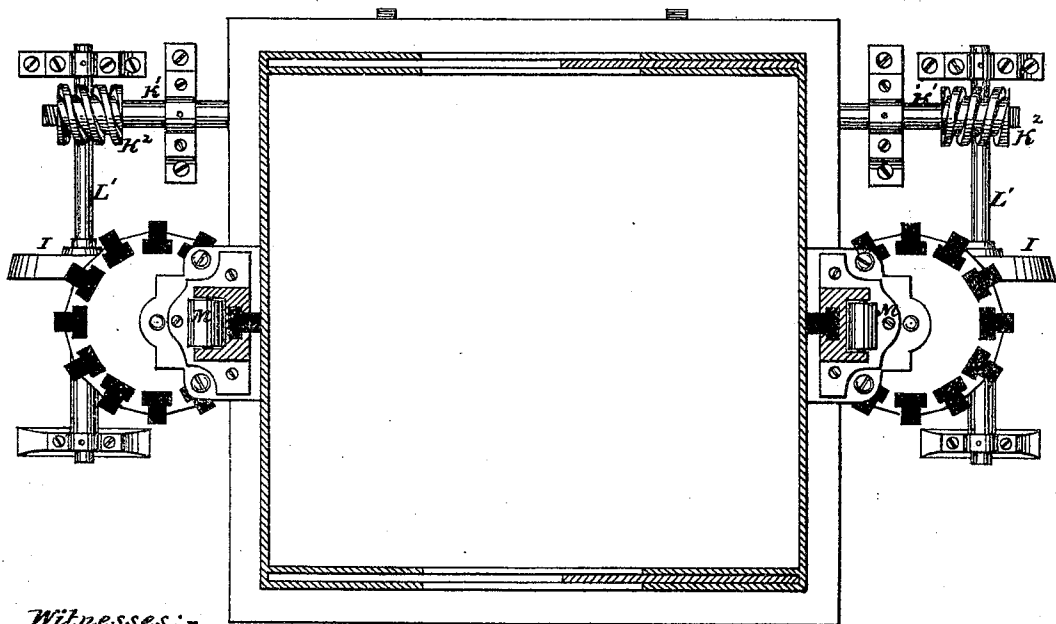

Fig. 5



Witnesses:-
Thomas E. Smith
J. R. Nottingham

Albert G. Hawkes
 by his atty.
 Burr & Rome

UNITED STATES PATENT OFFICE.

ALBERT G. HAWKES, OF BALTIMORE, MARYLAND, ASSIGNOR OF ONE-HALF HIS RIGHT TO F. J. HAYWARD AND E. L. BARTLETT, OF SAME PLACE.

IMPROVEMENT IN ELEVATORS.

Specification forming part of Letters Patent No. 129,339, dated July 16, 1872.

SPECIFICATION.

To all whom it may concern:

Be it known that I, ALBERT G. HAWKES, of Baltimore, in the county of Baltimore and State of Maryland, have invented certain new and useful Improvements in Elevators, of which the following is a specification:

My invention relates to that class of hoisting apparatus known as elevators, which are employed to raise goods and passengers from one floor to another of a building. The most important requisites of a machine for this purpose are strength, security, and certainty of operation. These features are found in that class of machines which employ a rotary screw for raising and lowering the car or platform; but the devices heretofore used of this class have been expensive and occupy considerable room, as the screw-shafts are long and extend the entire distance through which the car is to be raised. The object of my invention is to form a cheap and compact mechanism operating upon this principle, whereby the car or platform is pushed up at the sides from below instead of lifted from above or operated by lifting devices extending the entire length of the elevator-shaft; and the improvement consists, first, in combining a lifting-screw with sectional racks that are stowed away in a case in such manner that as each section is pushed up to lift the car another section is brought in gear with the lifting-screw, and so on until the car is raised to the desired height; second, in combining a screw or lifting device, the sectional racks, and a drum constructed to receive the racks and feed them to the screw one after another by its intermittent rotation, as hereinafter described; third, in combining the lifting-screw, the sectional racks, the drum to receive the racks, and the cam-wheel, constructed in such manner that it holds the drum in position while the sections are being withdrawn and replaced, and partially revolves the drum as each section leaves it to bring another section into position.

In the accompanying drawing, Figure 1 is a front elevation with one of its sides partly in section, showing so much of an elevator as is necessary to illustrate my invention; Fig. 2, a plan view of the gearing for operating the machine, partly in section, and with some of its parts broken away; Figs. 3 and 4, enlarged

face views of the cams for operating the drums when in the position shown in Fig. 2; and Fig. 5, a horizontal section of the machine in the line *xx* of Fig. 1.

The frame of the machine is composed of a base, A, which supports the gearing, and an upper frame, A¹, which is supported from the base by columns A², (see Fig. 5,) and forms a platform above the gearing for the car to rest upon when it is at the bottom of the elevator-shaft. The car B is supported and guided on both sides by uprights B' B', which are secured to the upper frame A¹, and also to the walls of the shaft through which the car passes. The devices for raising and lowering the car are also applied at both sides of it, so that the machinery for operating these devices are alike on both sides of the central line *zz*, as shown in Figs. 1 and 2 of the drawing, and the letters of reference hereinafter given will refer to either one side or the other. A driving-shaft, C, is driven by a pulley, D, that is driven by the prime mover, and has a beveled gear-wheel, E, secured to each of its ends. A vertical shaft, F, resting on a socket, *f*, on the base A, and supported at its upper end by a bearing, *f'*, on the frame A¹, is provided with a beveled pinion, F¹, on its lower end that meshes with the beveled wheel E and is revolved by it. The upper end of the shaft is provided with a short screw or worm, F², that gears with a rack divided into sections G¹, G², G³, &c., the number of which depends upon the height of the elevator-shaft. These sections are stowed away in a drum, H, in such manner that as the screw draws each rack out of the drum it makes the rack enter a groove in the upright B' and raises the car, which rests upon the upper end of the first rack. The rack-sections are in this instance of a T-shaped cross-section, and the grooves in the drum and upright, into which they fit, are of a corresponding shape, so that they are prevented from falling out of place, but permitted to be easily withdrawn or replaced when desired. In order to bring the sections of the rack successively into gear, the drum is secured to a vertical shaft, H¹, that has its bearings in the base A and the upper frame A¹, and is caused to make a partial revolution as each section is withdrawn or replaced, so that the following section is

brought in line with the upright B' and the section that has preceded it. The drum is revolved at proper intervals by a cam, I, of peculiar construction, as hereinafter described, that operates upon a pin-wheel, H², on the drum-shaft, and is driven from the main driving-shaft in the following manner: A spur-gear, J, is secured to the driving-shaft C and meshes with a corresponding gear, K, on a countershaft, K¹, that revolves in suitable bearings secured to the base A of the frame. The countershaft K¹ has a worm, K², secured to it, (shown in Fig. 5 and broken away in Fig. 2,) that turns a worm-wheel, L, on a shaft, L', at right angles to the shaft K¹, and journaled in bearings secured to the frame of the machine. The cam I is secured to the shaft L' and revolves continually with it. In order that the ends of the rack-section may be in close apposition as they ascend the uprights, the rack-sections are made to project a certain portion of their length above the drums, so that as the lower end of one section leaves the drum the upper end of the following section will project sufficiently above it to compensate for the distance traveled by the first section while the following section is being brought into position by the movement of the drum, and thus place their adjacent ends in close contact with each other. To further this object the drum should revolve as each section leaves it, and, having done so, maintain the rack in position during its ascent. This is accomplished by means of the cam I, and in the following manner: The cam I makes one revolution for every rack-section in the drum, so that when twelve racks are employed, as shown in the drawing, the cam I will make twelve revolutions to every revolution of the drum. The number of pins in the wheel H¹ on the drum-shaft correspond with the number and position of the racks in the drum, so that their movements are identical. The cam I has a flange projecting from its face that is concentric with the shaft a certain portion of its length and eccentric the remainder. The flange of the cam-wheel engages with a pin on the wheel H¹ of the drum-shaft, and while the pin is in contact with the concentric part of the flange the drum will be held in position; but when the eccentric part of the flange meets the pin (see Figs. 3 and 4) the drum will be revolved a distance

proportionate to the eccentricity of the cam, and as there are twelve racks employed the cam must move one of the pins of the wheel H¹, and with it the drum, through an angle of thirty degrees, or one-twelfth of a revolution. The concentric part of the cam-flange will then be in contact with the succeeding pin of the wheel H¹, and the drum will be again held in position until the following rack-section is withdrawn from or replaced in the drum. In order that the car may move smoothly and freely up and down without rattling and jarring, the uprights are cut away at proper intervals, and rubber rollers M are placed in the openings, so that their surfaces will press gently against the side irons b and rack-sections G¹, &c., as the car passes between the guides, and act as friction-rollers, and also yield sufficiently to prevent noise and permit the car to move freely between the guides.

Some of the devices herein described may be modified in various ways without departing from the spirit of my invention; and although I prefer to use a screw for raising the rack-sections in combination with the revolving drum, other mechanical devices could be substituted—as, for instance, a spur-gear or ratchet mechanism; and, on the other hand, a horizontally-moving case to receive the rack-sections could be substituted for the revolving drum when the lifting-screw is used in the combination.

I claim as new and desire to secure by Letters Patent—

1. The combination of the lifting-screw, the rack-sections, and a case to hold the sections and present them successively to the screw, substantially as described.
2. The combination of a lifting device, the sectional-rack, and a drum constructed to receive the racks and feed them to the screw one after another by its intermittent rotation, substantially as described.
3. The combination of a lifting device, the sectional racks, the drum, and the cam to revolve the drum at the proper moment and hold it in position while the rack-sections are being withdrawn or replaced, substantially as described.

ALBERT G. HAWKES.

Witnesses:

E. L. BARTLETT,
W. S. WILKINSON.