

J. G. Lane,

Trunk.

No. 110,575.

Patented Dec. 27, 1870.

Fig. 1.

Fig. 2.

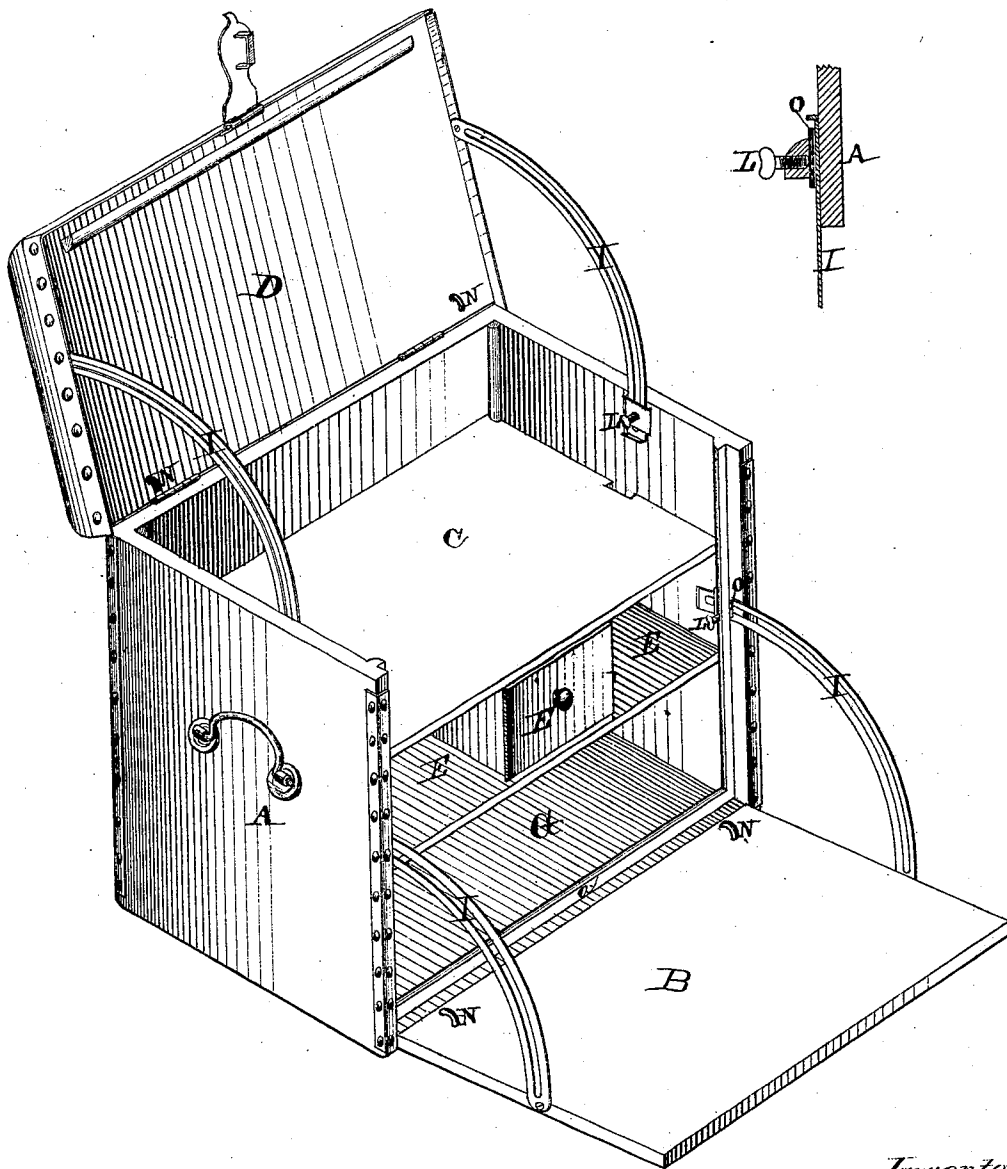

Witnesses:
Thos. S. Mercer
C. S. Fisher

Inventor

J. G. Lane

United States Patent Office.

JOHN G. LANE, OF ST. LOUIS, MISSOURI.

Letters Patent No. 110,575, dated December 27, 1870.

IMPROVEMENT IN TRUNKS.

The Schedule referred to, in these Letters Patent and making part of the same.

To all whom it may concern :

Be it known that I, JOHN G. LANE, of St. Louis, Missouri, have invented certain Improvements in Trunks, of which the following is a specification.

Nature and Objects of the Invention.

The first part of my invention consists in providing the cover and hinged front of my trunk with curved slotted guides, against which a piece of rubber is pressed by means of a thumb-screw, so that the cover and front can be retained in any desired position when open.

The second part consists in providing the hinged front piece with a number of hooks or clasps, which extend over and grasp a projection on the floor of the trunk when the front is closed, so that, should the hinges of this piece be broken off, these clasps or hooks will hold it firmly in place.

The third part consists in the general arrangement and combination of the different parts of my trunk, as will hereafter be more fully set forth.

Description of the Accompanying Drawing.

Figure 1 is a perspective of my trunk.

Figure 2 is a section view of my clamping device, by which the lid and front are held at any desired angle when opened.

A represents a trunk, the front part B of which is hinged to the body so as to be opened and closed in the usual manner. The interior of the trunk may be divided into any desired number of compartments, drawers, and shelves, which can be arranged in any desired manner.

For instance, there may be an open compartment, C, upon the top, which is covered by the lid D, and immediately below this there may be arranged a number of drawers E, one of which may be a secret one, while under the drawers there is an open space, G, extending the whole length of the body, which may be fitted with a drawer or a set of shelves. I do not wish, however, to be limited to this precise arrangement.

To both the lid D and hinged front B there is attached at each end a curved slotted guide, I, by which the opening and closing of these parts are regulated.

Just outside of the frame A, near the edges, there is arranged a set-screw, L, for each one of the guides, the ends of which screws bear and press against a piece of rubber or any suitable substance, O, so as to produce friction against the guides as they are moving back and forth.

Frequently, when the trunk is opened, it is desirable to keep the lid D or front B at a certain position or angle, and so as to prevent their suddenly falling, which is accomplished by my device.

By means of the screw L, the pressure of the rubber O can be regulated to any desired degree against the guides, so as to produce sufficient friction to allow them to be readily moved by manual force, and yet sufficient to retain them at any desired angle at which they may be placed.

Near the lower edge of the hinged front B and lid D there is arranged one, two, or more hooks or clasps N, which, when the front and lid are closed, extend over and grasp any suitable projection a, placed in the bottom of the trunk or the top part of the trunk itself.

If, by any accident or otherwise, the hinges of these parts should be broken or injured, these hooks or clasps hold it firmly and securely in place.

Having thus described my invention,

What I claim as new, and desire to secure by Letters Patent, is—

The frame A, front B, and lid D provided with the hooks or clasps N, the curved slotted guides I, thumb-screw L and rubber O and projection a, when all are combined to operate substantially as shown and specified.

JOHN G. LANE.

Witnesses :

THOS. S. MERCER,
C. H. FOWLER.