



US 20040154341A1

(19) **United States**

(12) **Patent Application Publication**

Conti

(10) **Pub. No.: US 2004/0154341 A1**

(43) **Pub. Date: Aug. 12, 2004**

(54) **DEVICE FOR PICKING UP A TUBULAR KNITTED ARTICLE FROM A KNITTING MACHINE AND FOR SEWING THE TOE**

Publication Classification

(51) **Int. Cl.⁷ D04B 35/00; D04B 27/34; D04B 15/88**

(52) **U.S. Cl. 66/149 S**

(76) **Inventor: Paolo Conti, Firenze (IT)**

(57) **ABSTRACT**

Correspondence Address:
MCGLEW & TUTTLE, PC
1 SCARBOROUGH STATION PLAZA
SCARBOROUGH, NY 10510-0827 (US)

Described herein is a device for picking up a tubular knitted article (M) from a cylinder (5) of a circular knitting machine (3) and for closing the toe of said article. The device comprises a sewing machine for sewing the toe of the tubular article and a suction pipe (13) which develops from an intake end (13A), in an area where the tubular article is picked up from the circular knitting machine, to an output end (13B), in an area where the toe of the article is sewn. Also provided is a guide element (15) for guiding the tubular article, said guide element developing inside said suction pipe and extending inside the cylinder of the circular knitting machine. Between the guide element (15) and the inner wall of the suction pipe (13) there remains a space for transit of the tubular article.

(21) **Appl. No.: 10/471,186**

(22) **PCT Filed: Mar. 4, 2002**

(86) **PCT No.: PCT/IT02/00129**

(30) **Foreign Application Priority Data**

Mar. 8, 2001 (IT) FI2001A000038

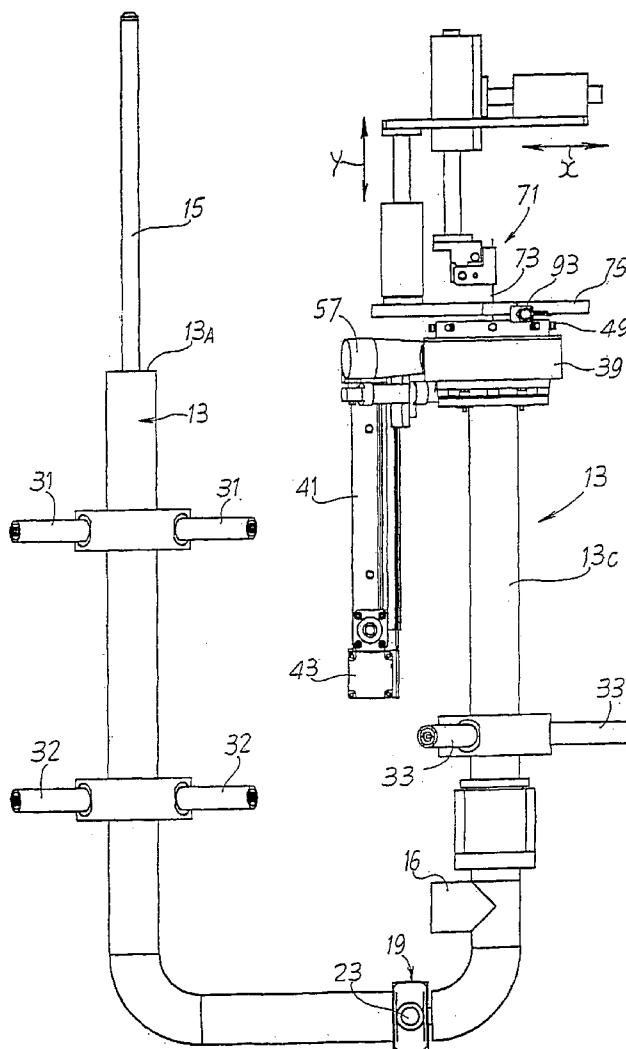

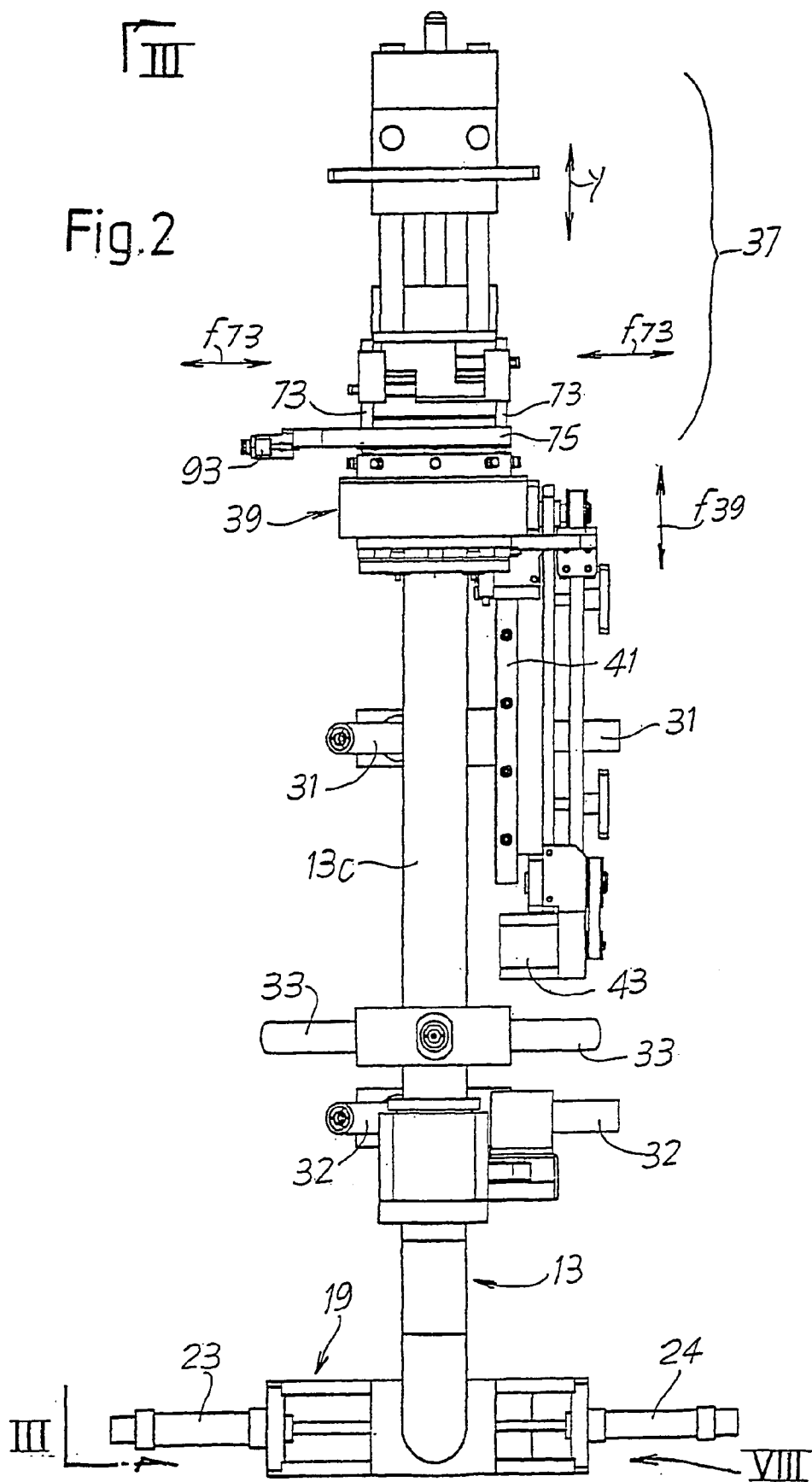

Fig. 3

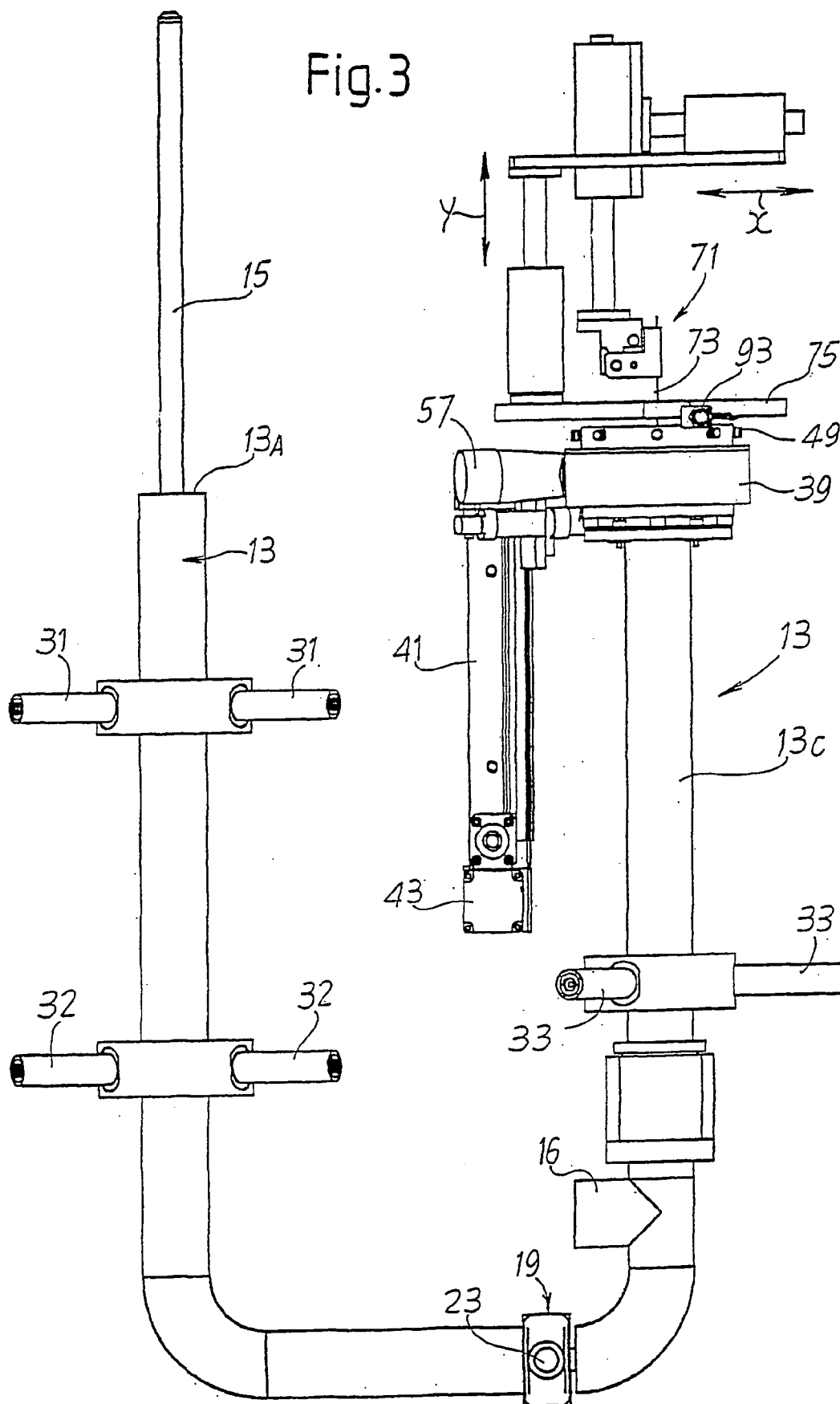

Fig. 4

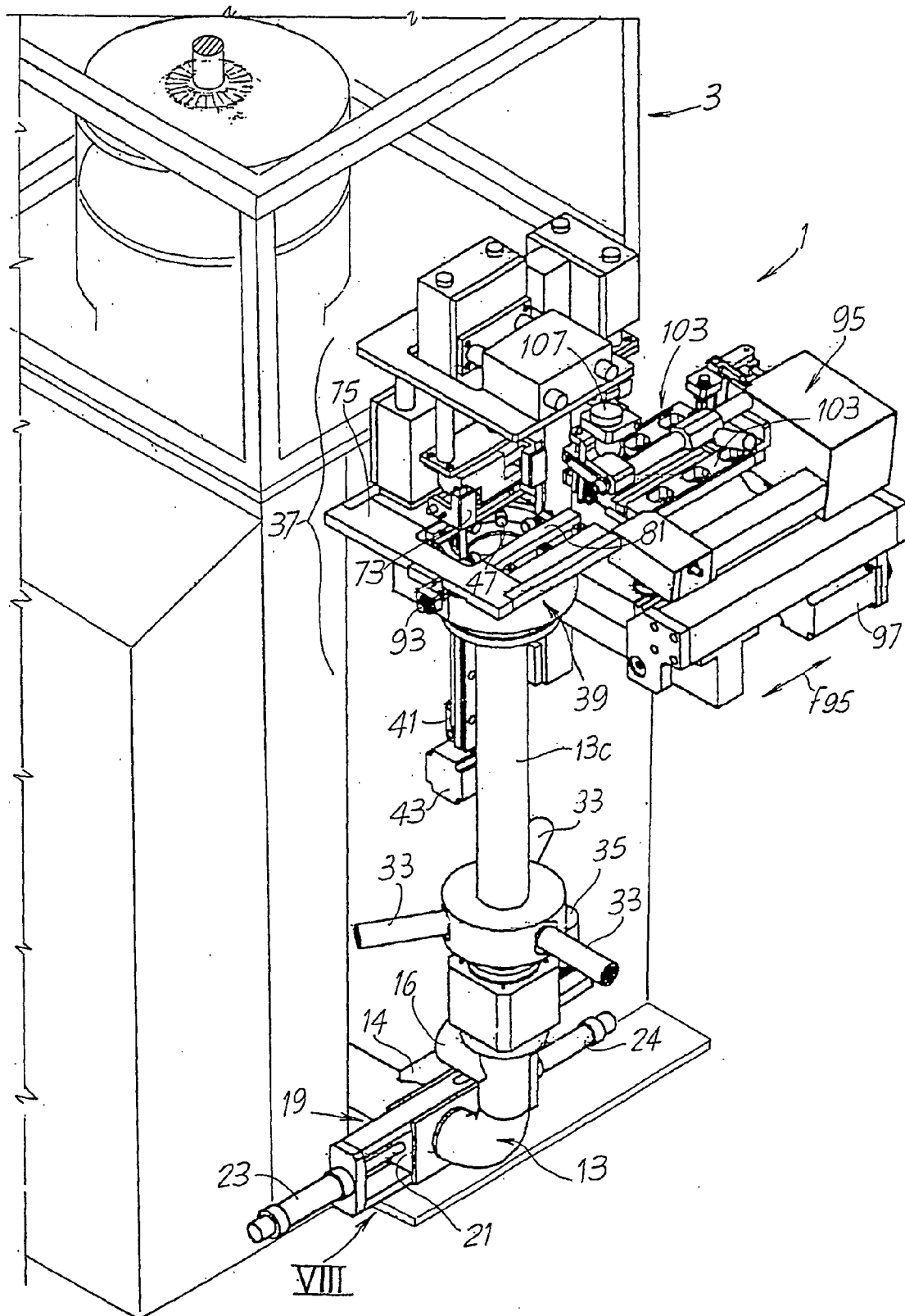
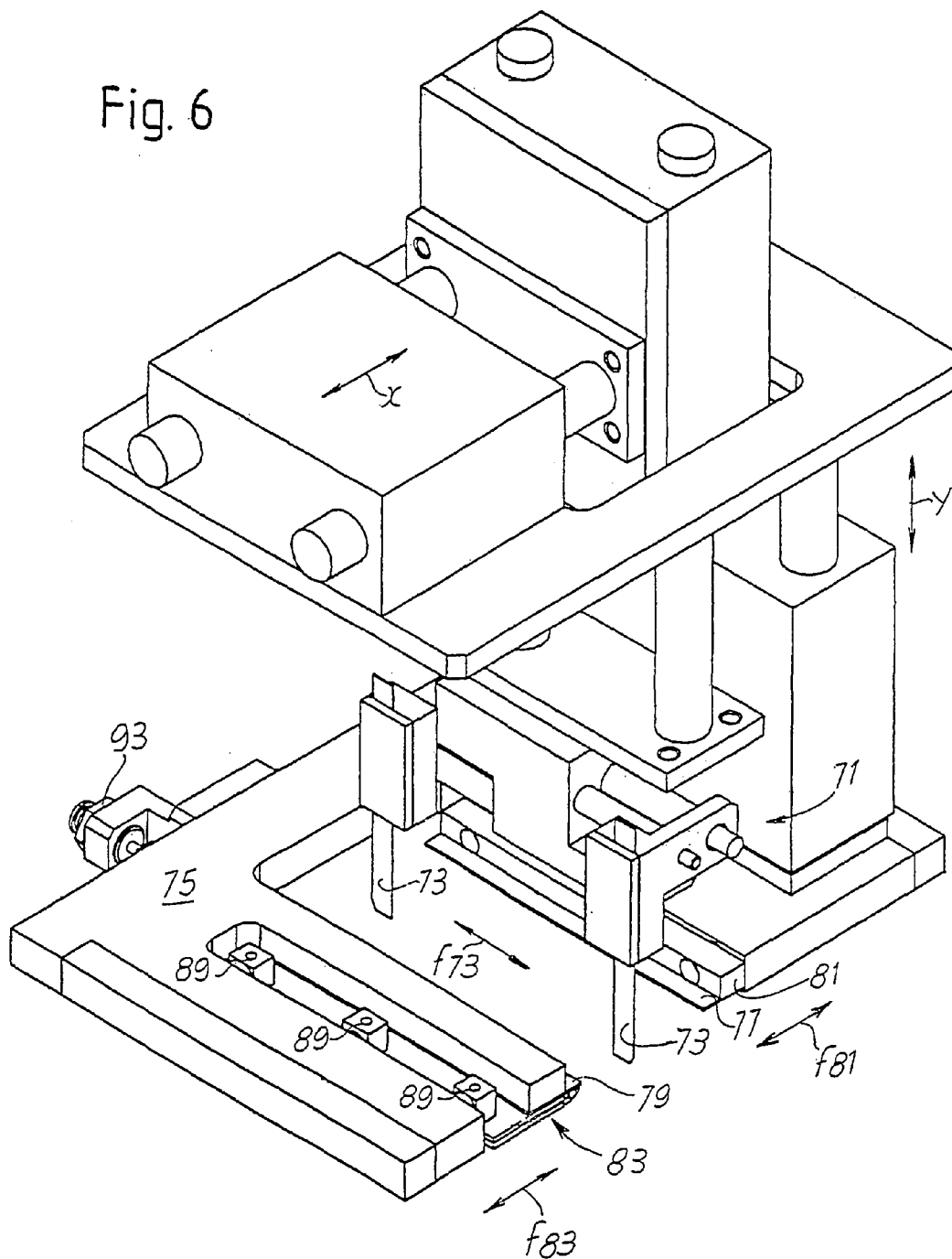
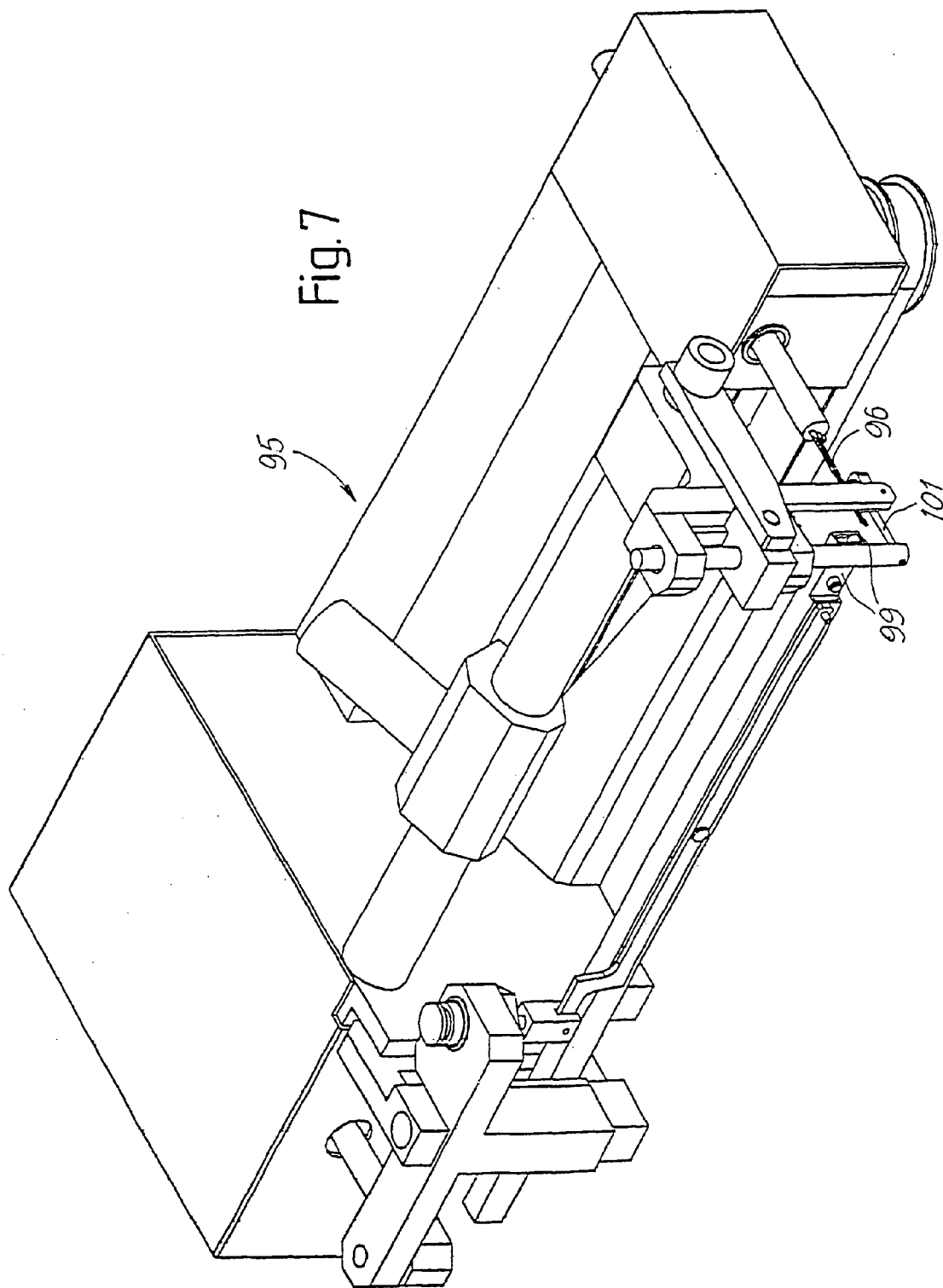
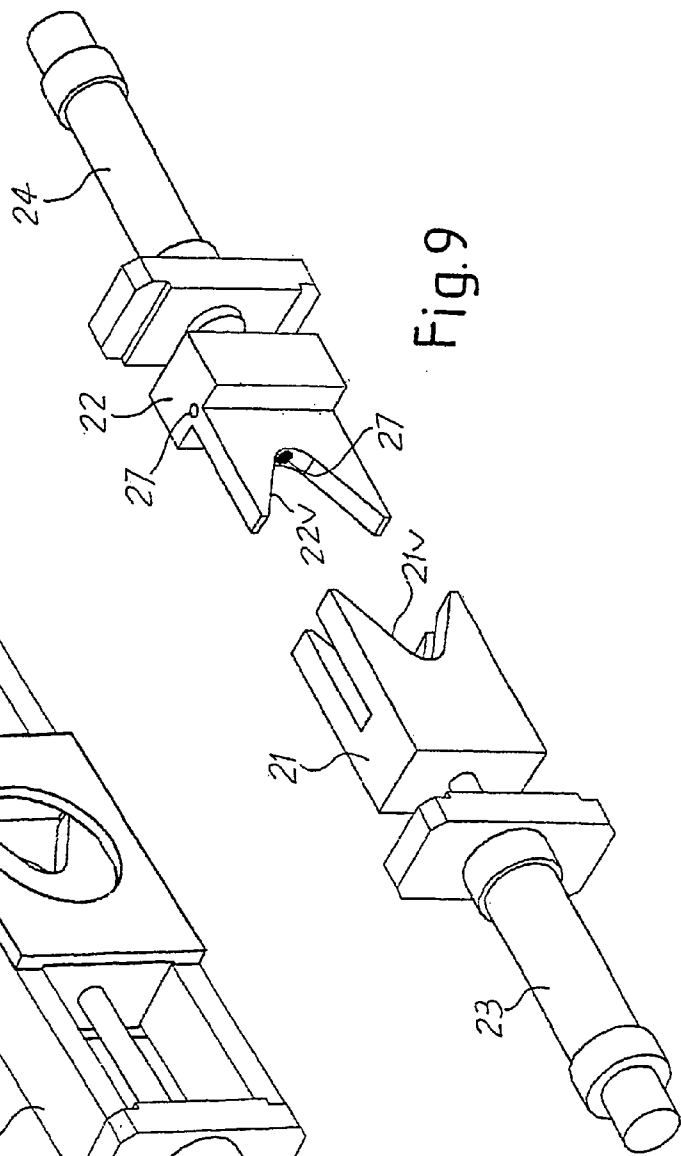
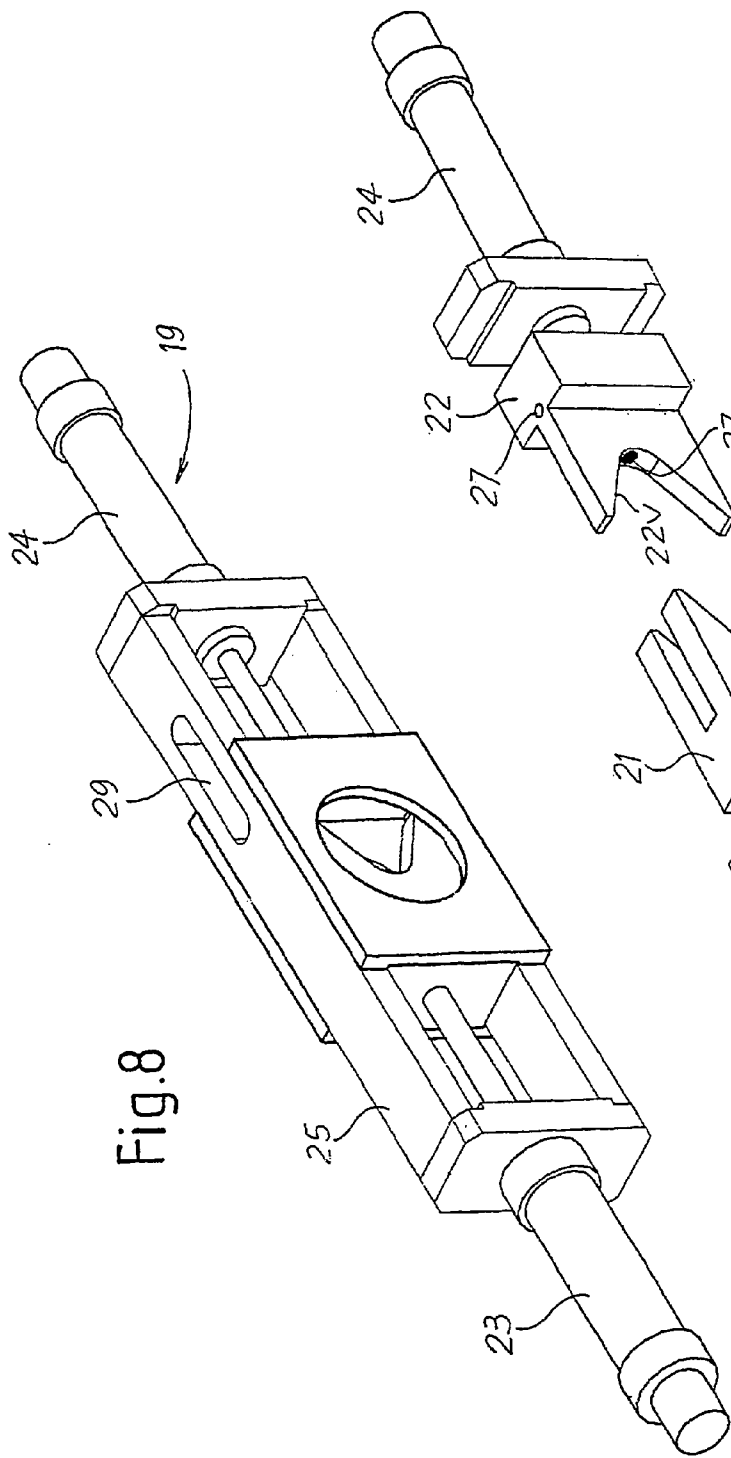

Fig. 6







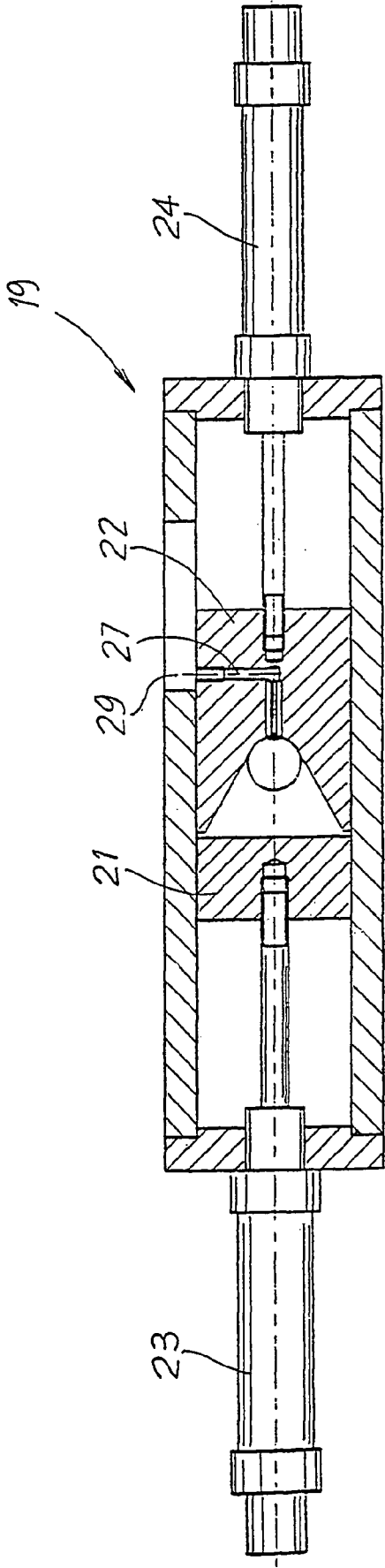

Fig.10

Fig.11

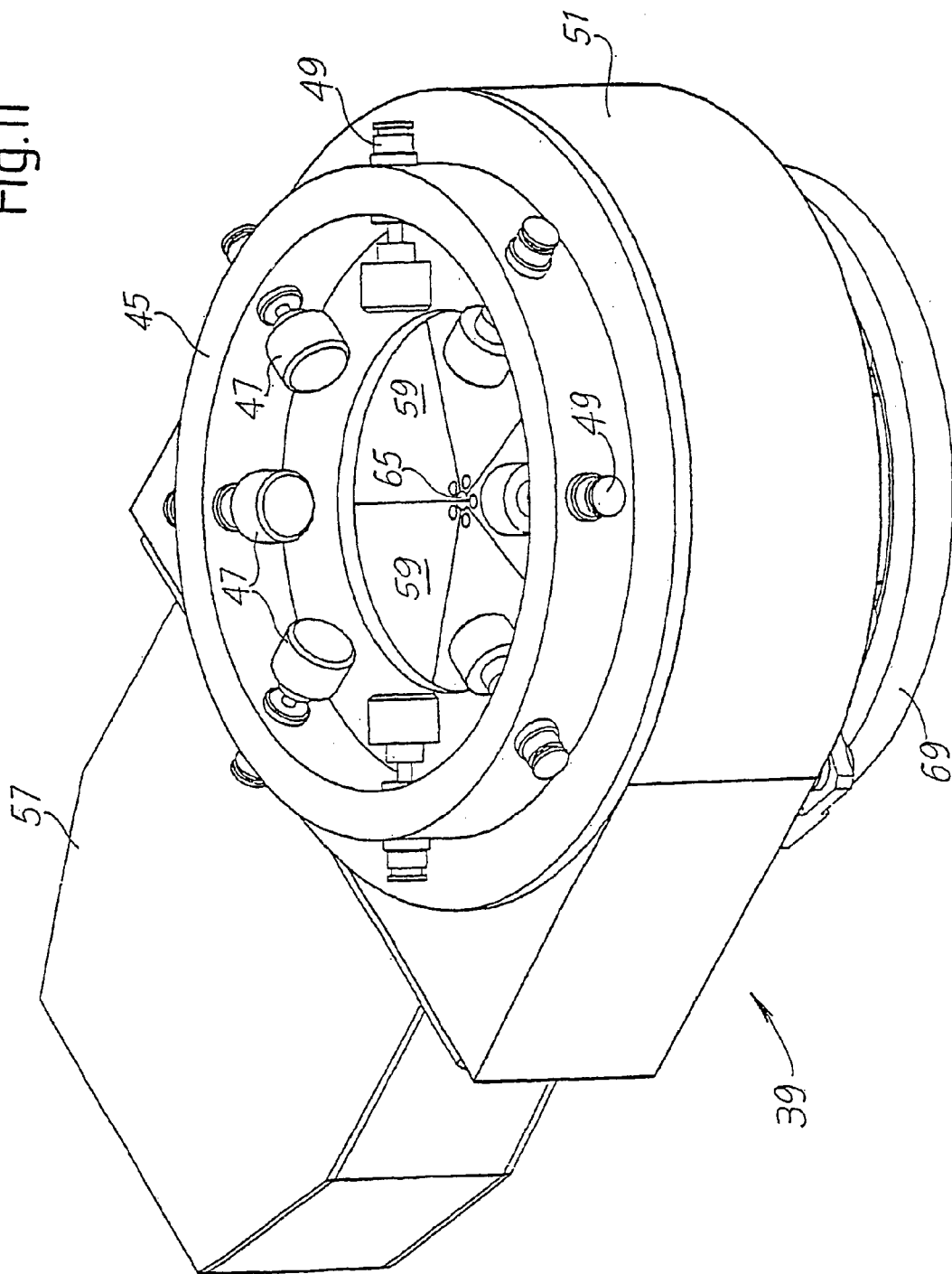

Fig.12

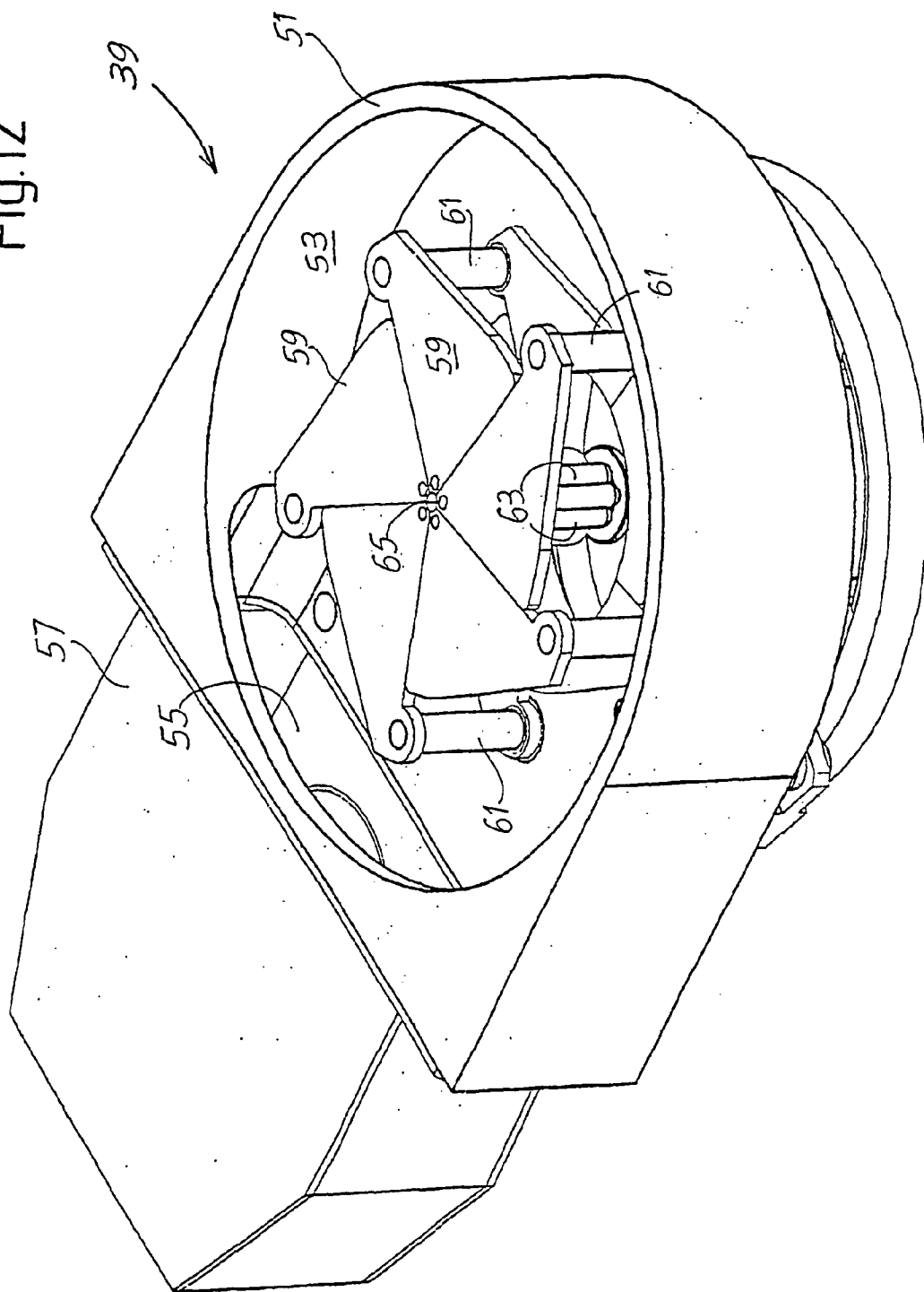

Fig. 13

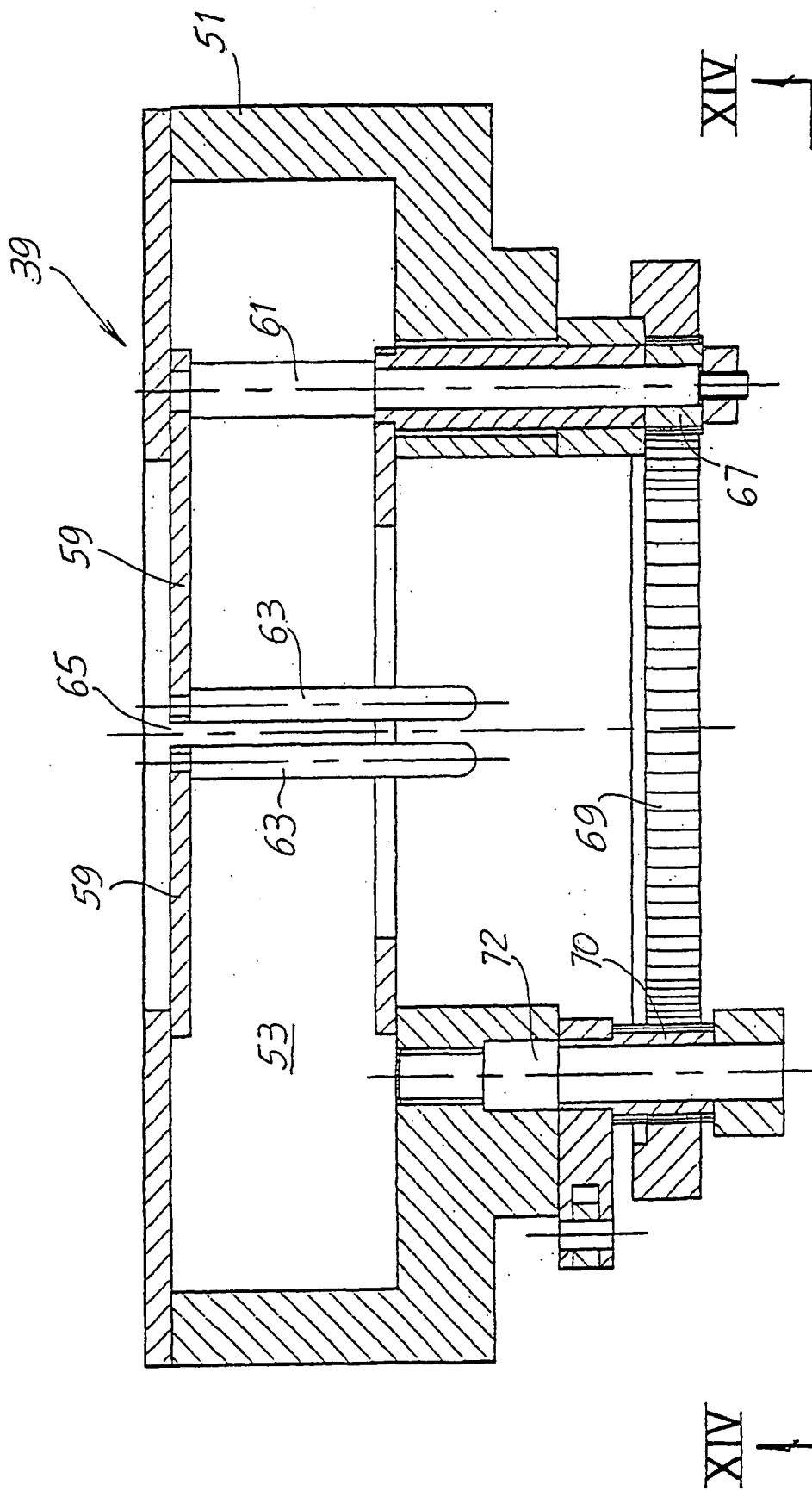
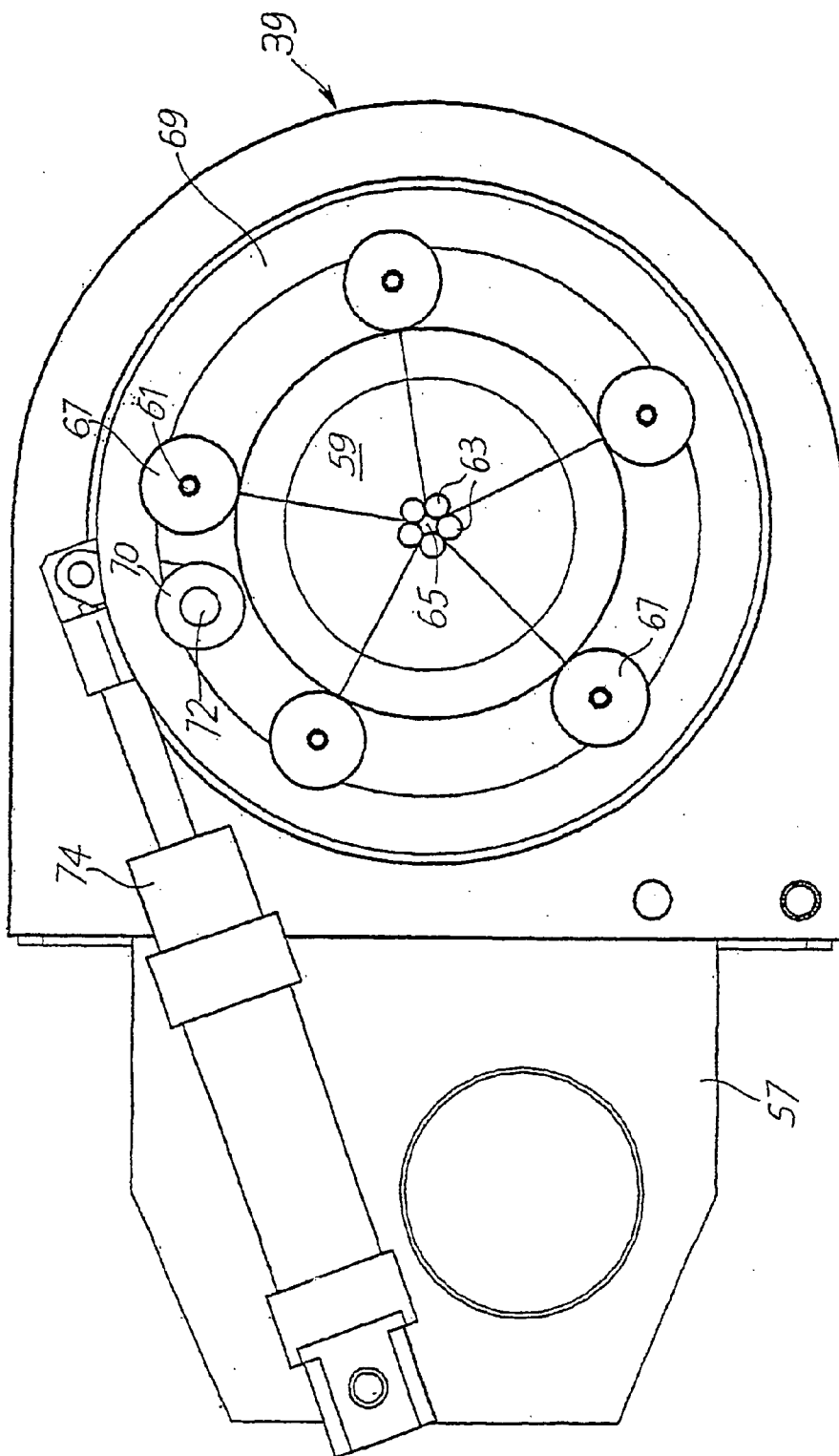
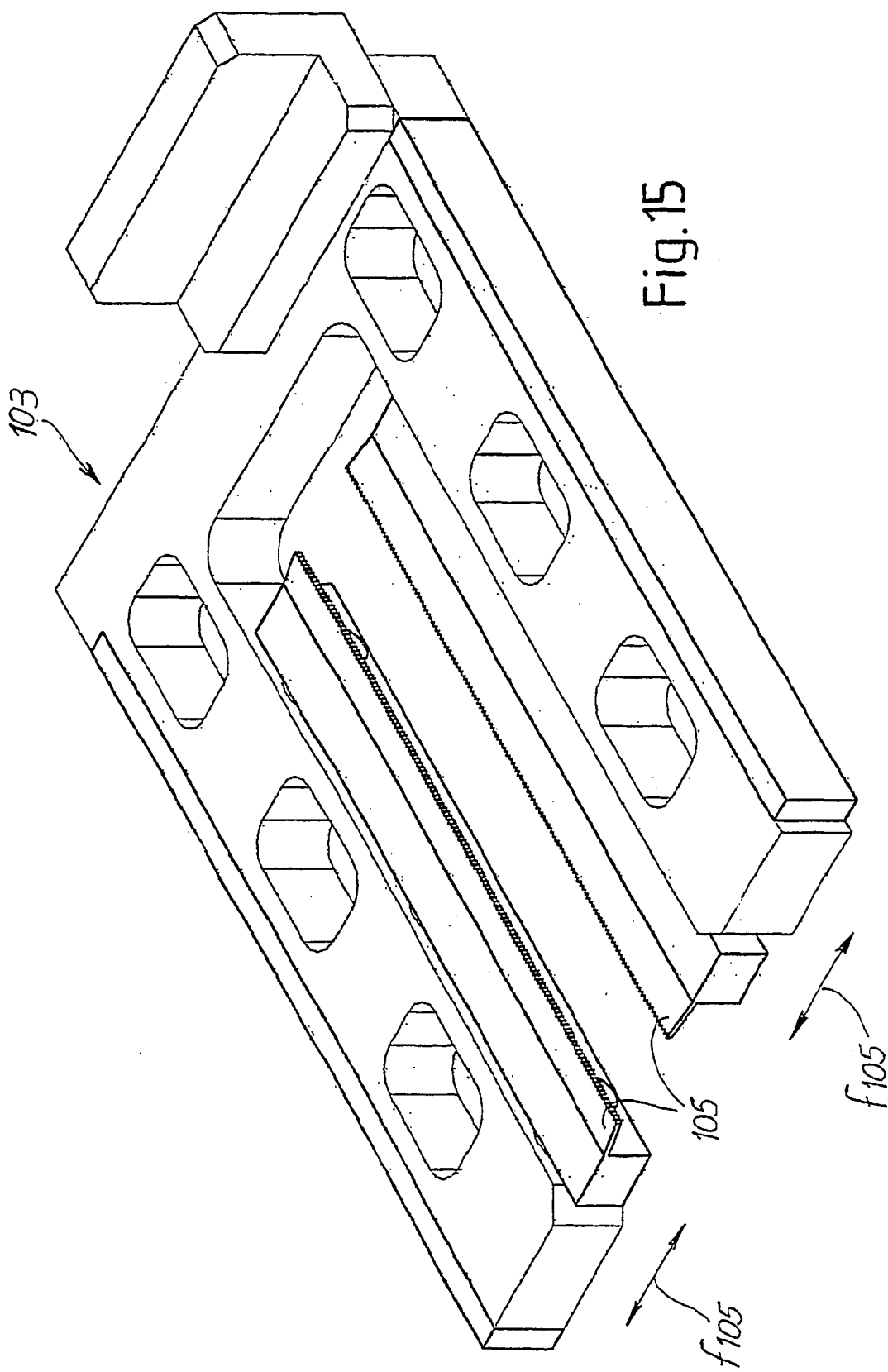

Fig. 14





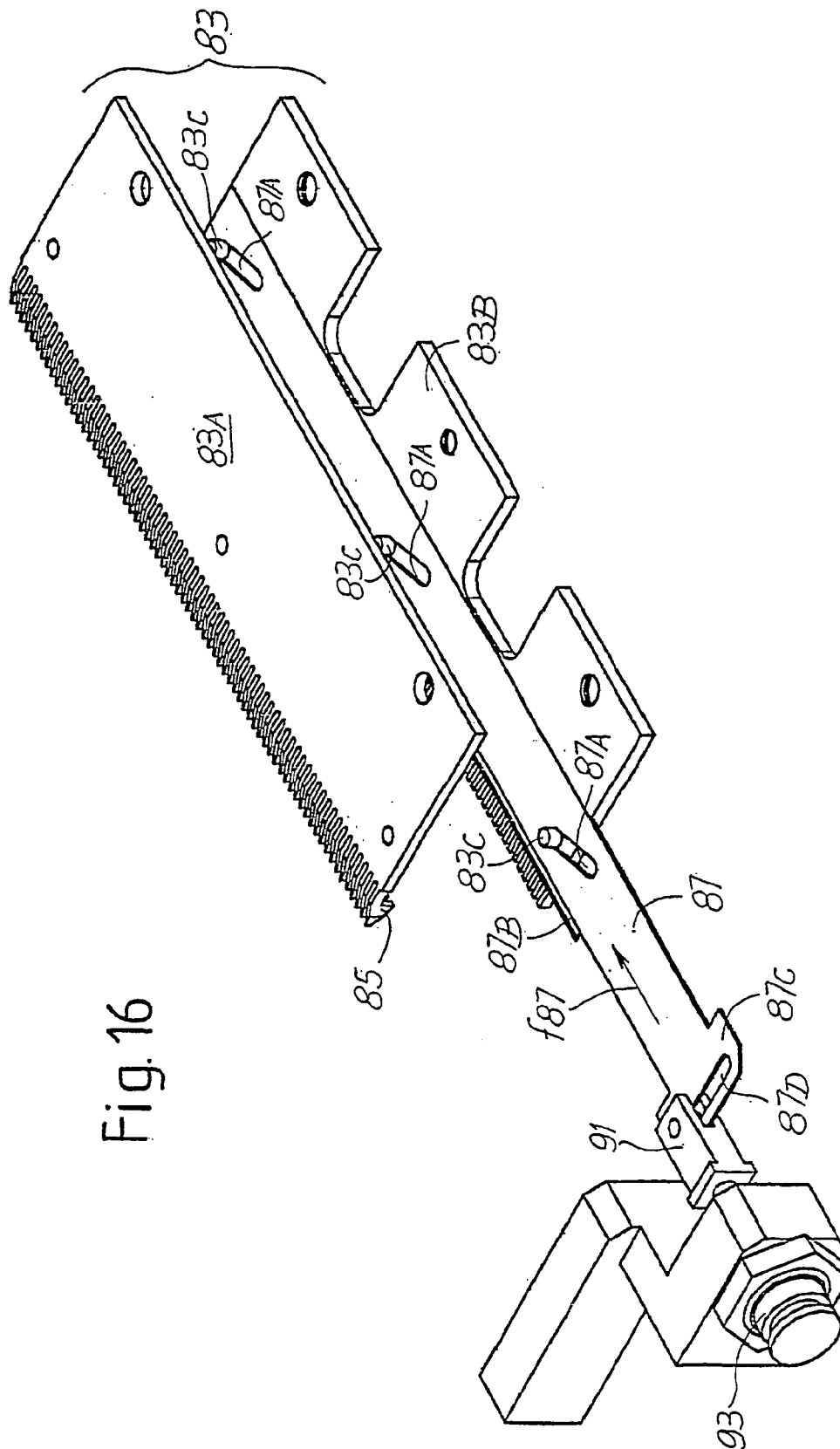

Fig. 16

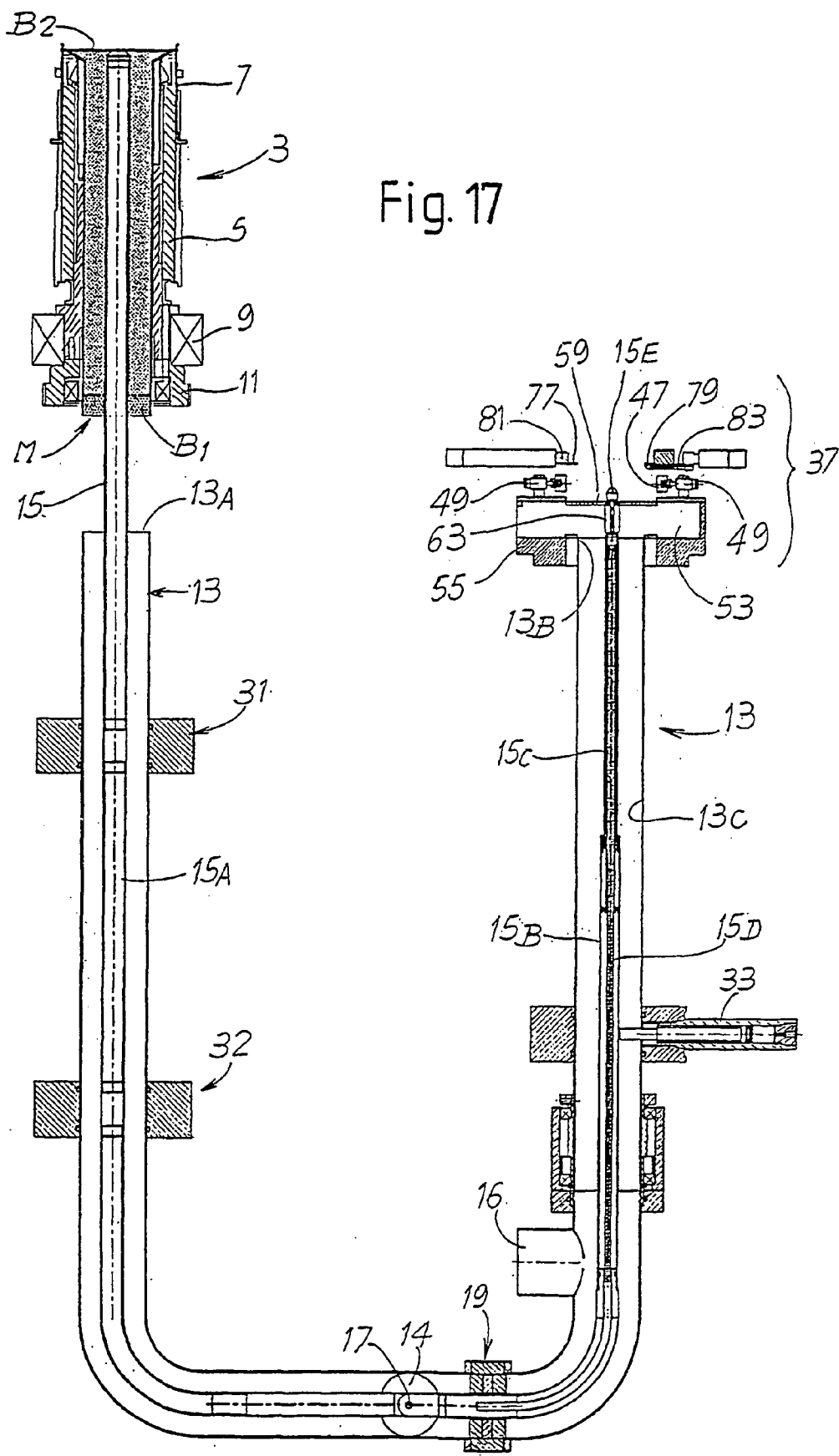
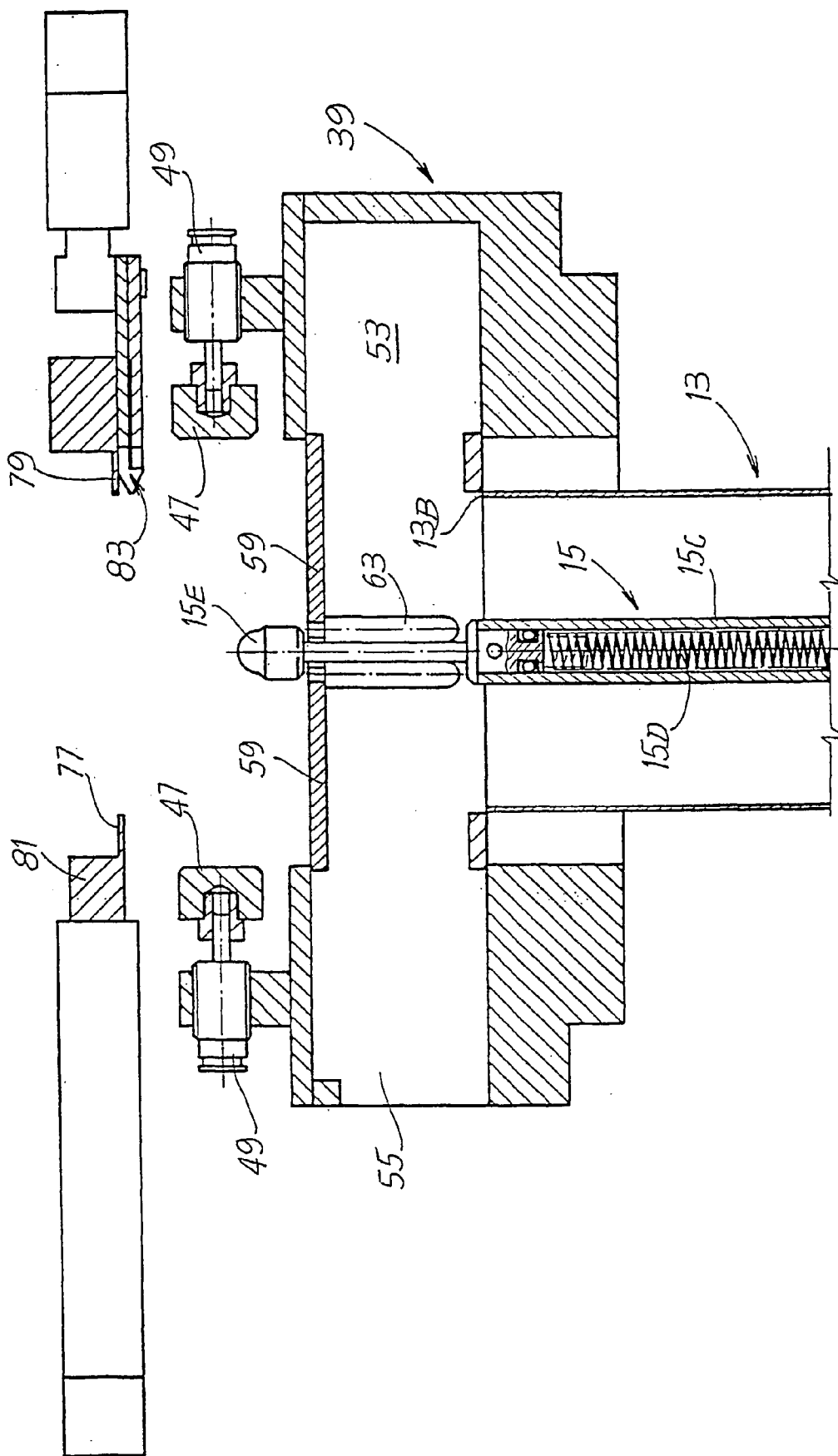
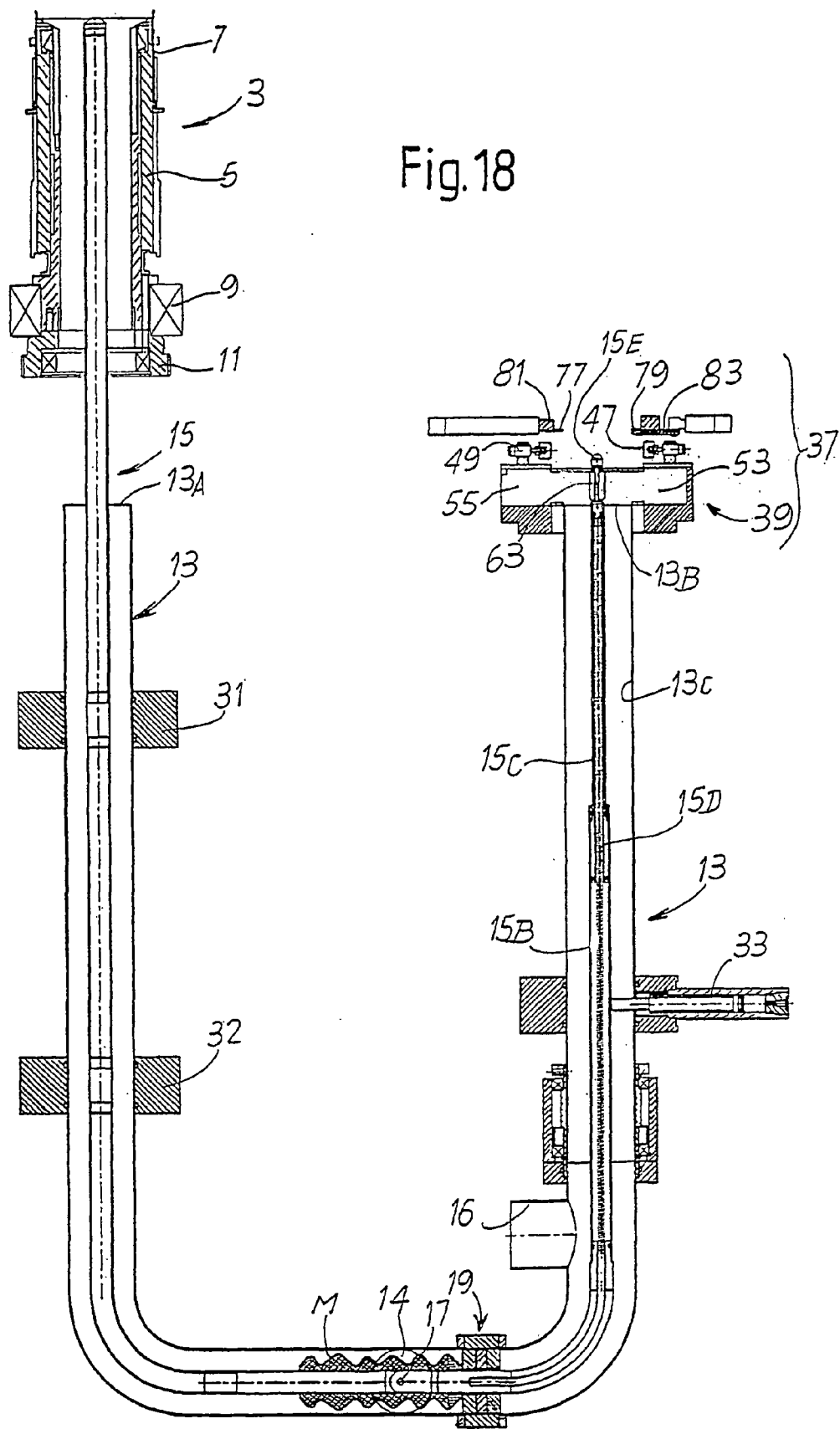

Fig. 17

Fig. 17A





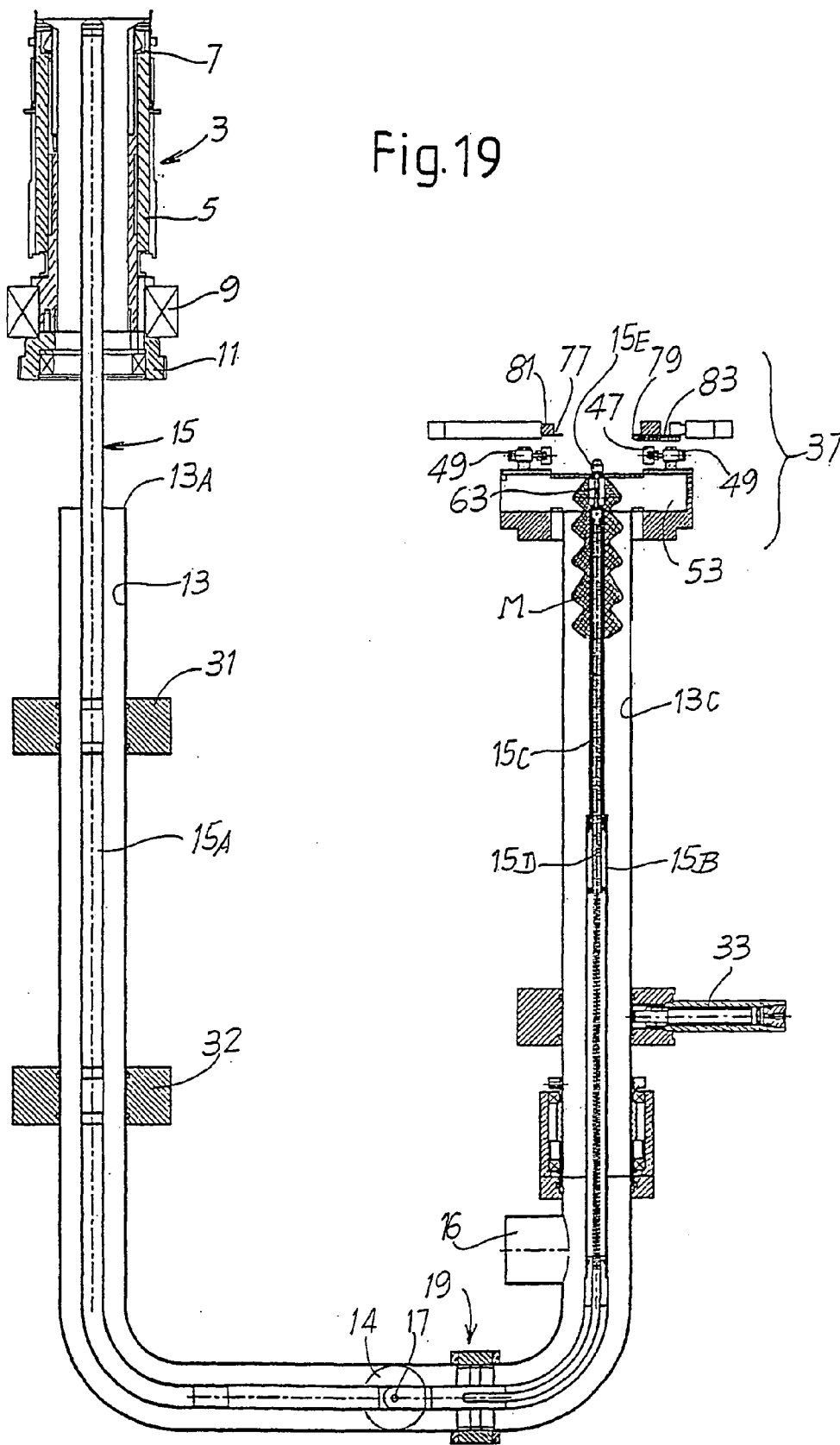

Fig.19

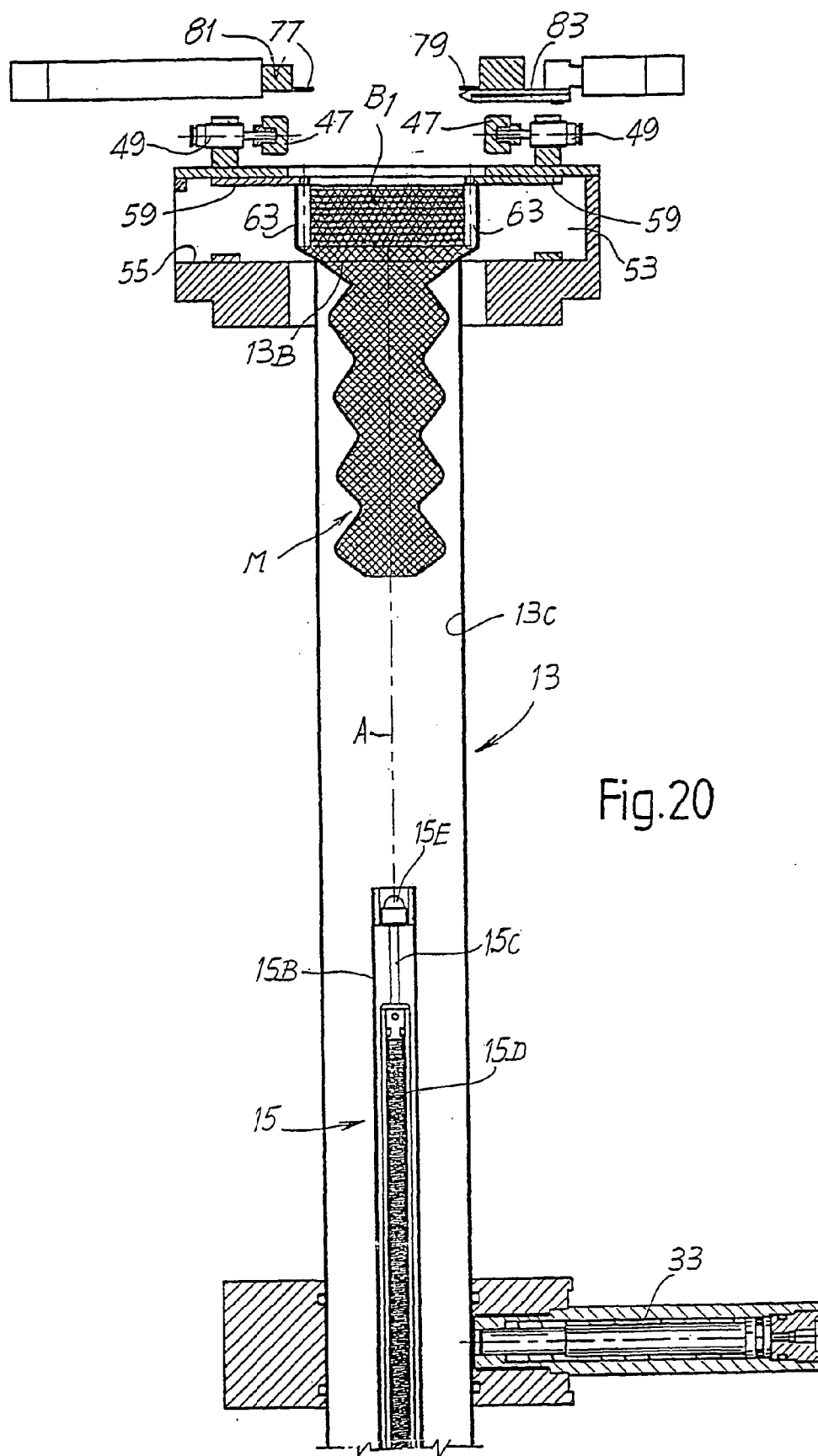

Fig. 20

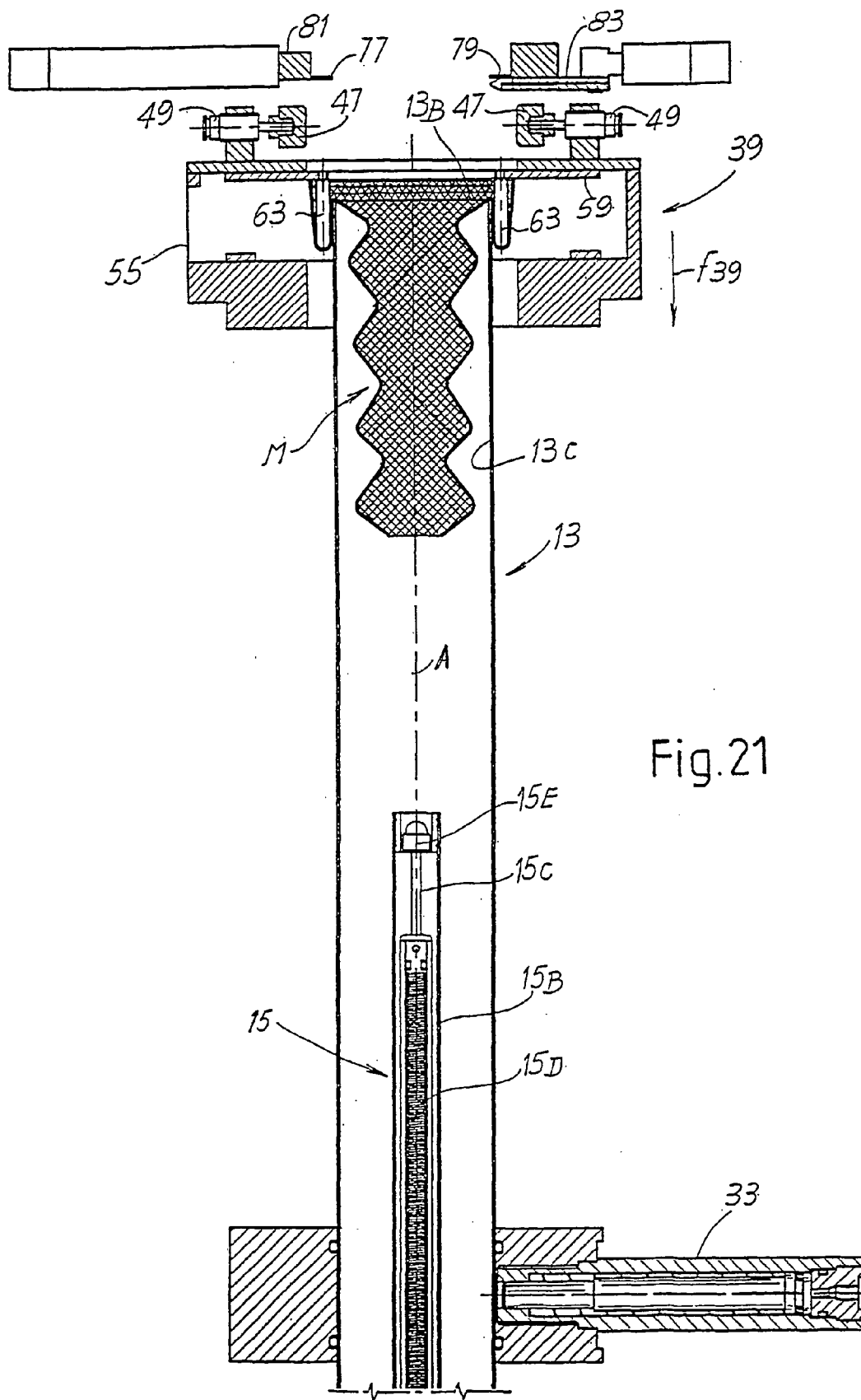

Fig. 21

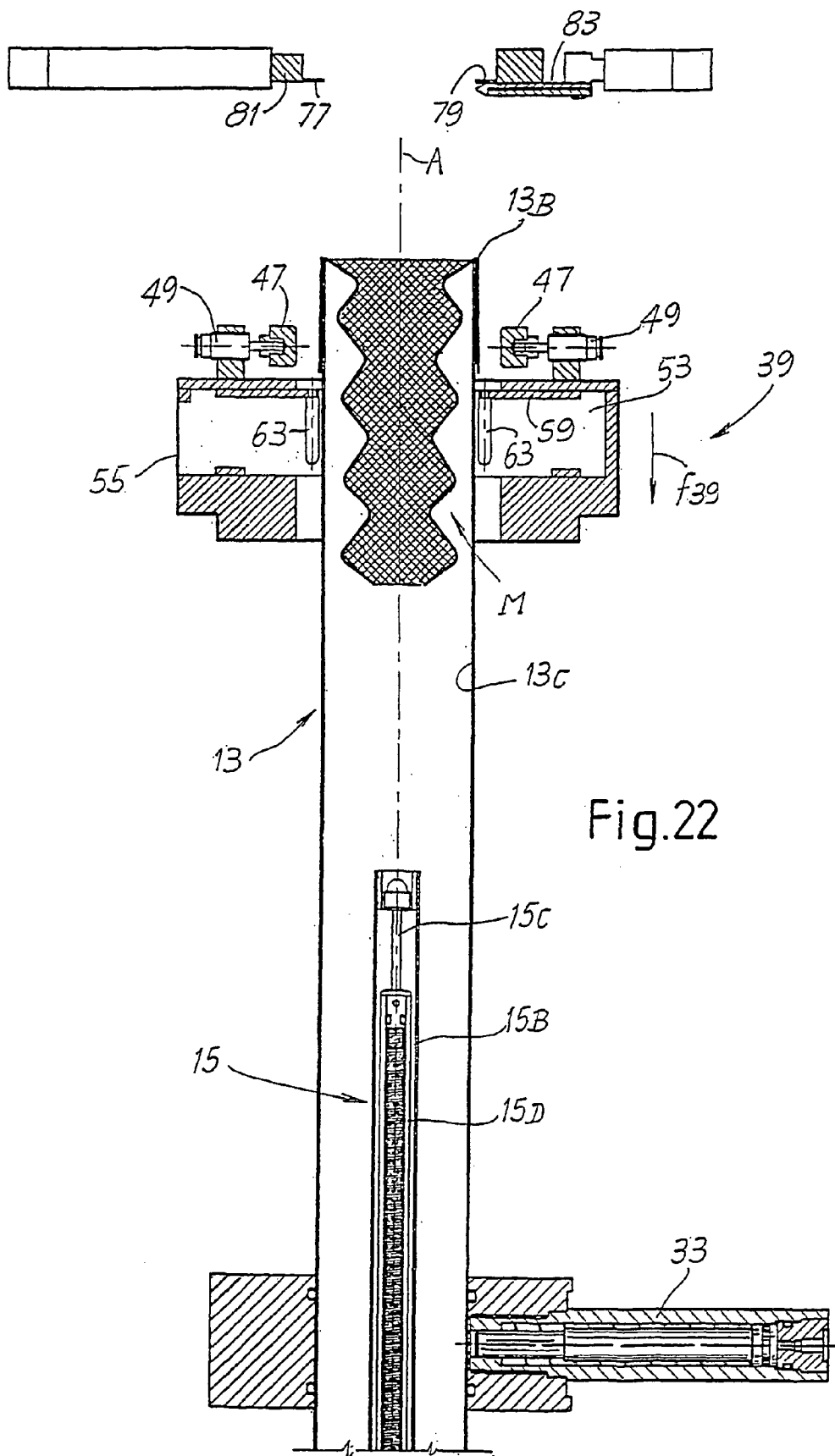

Fig.22

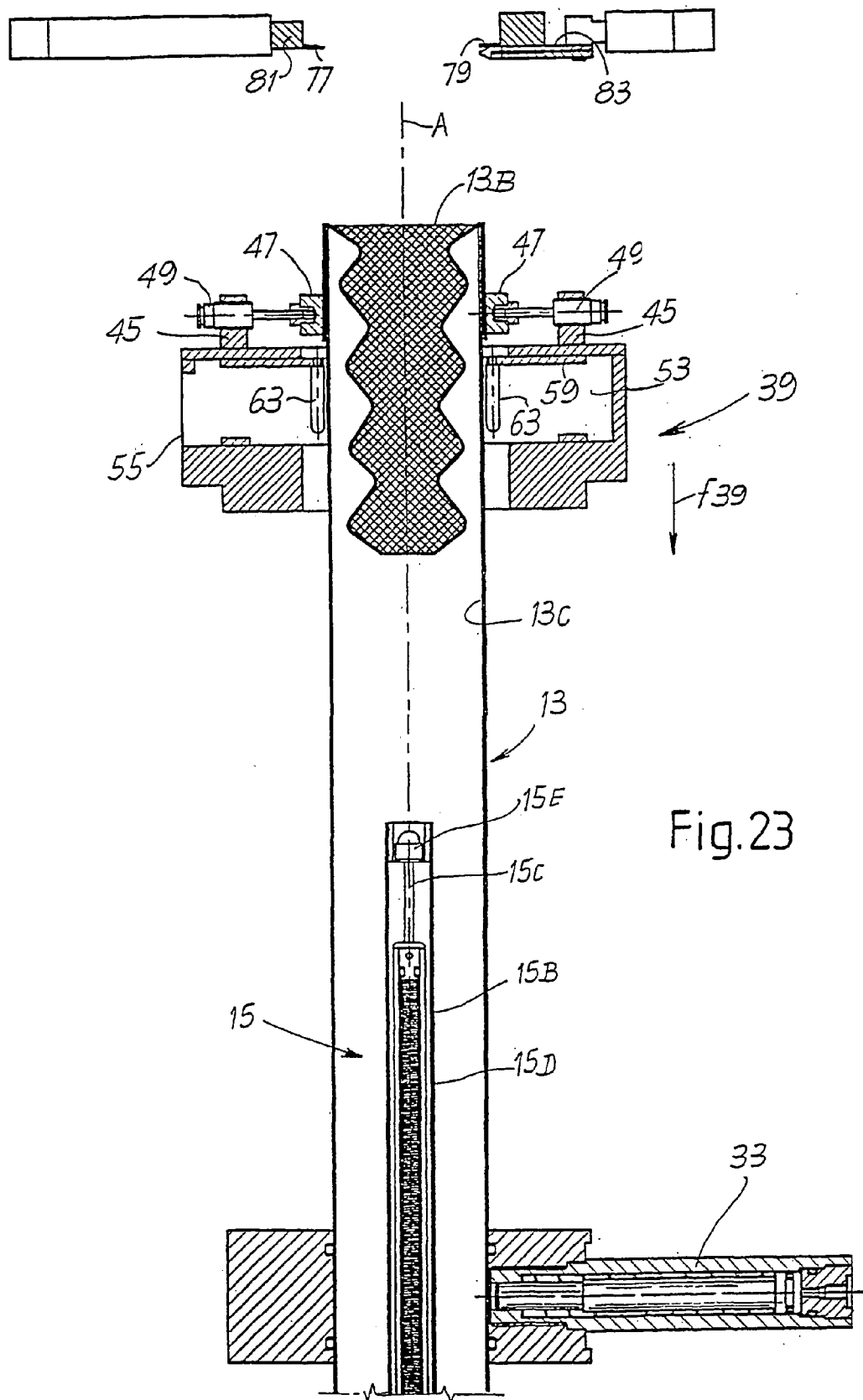
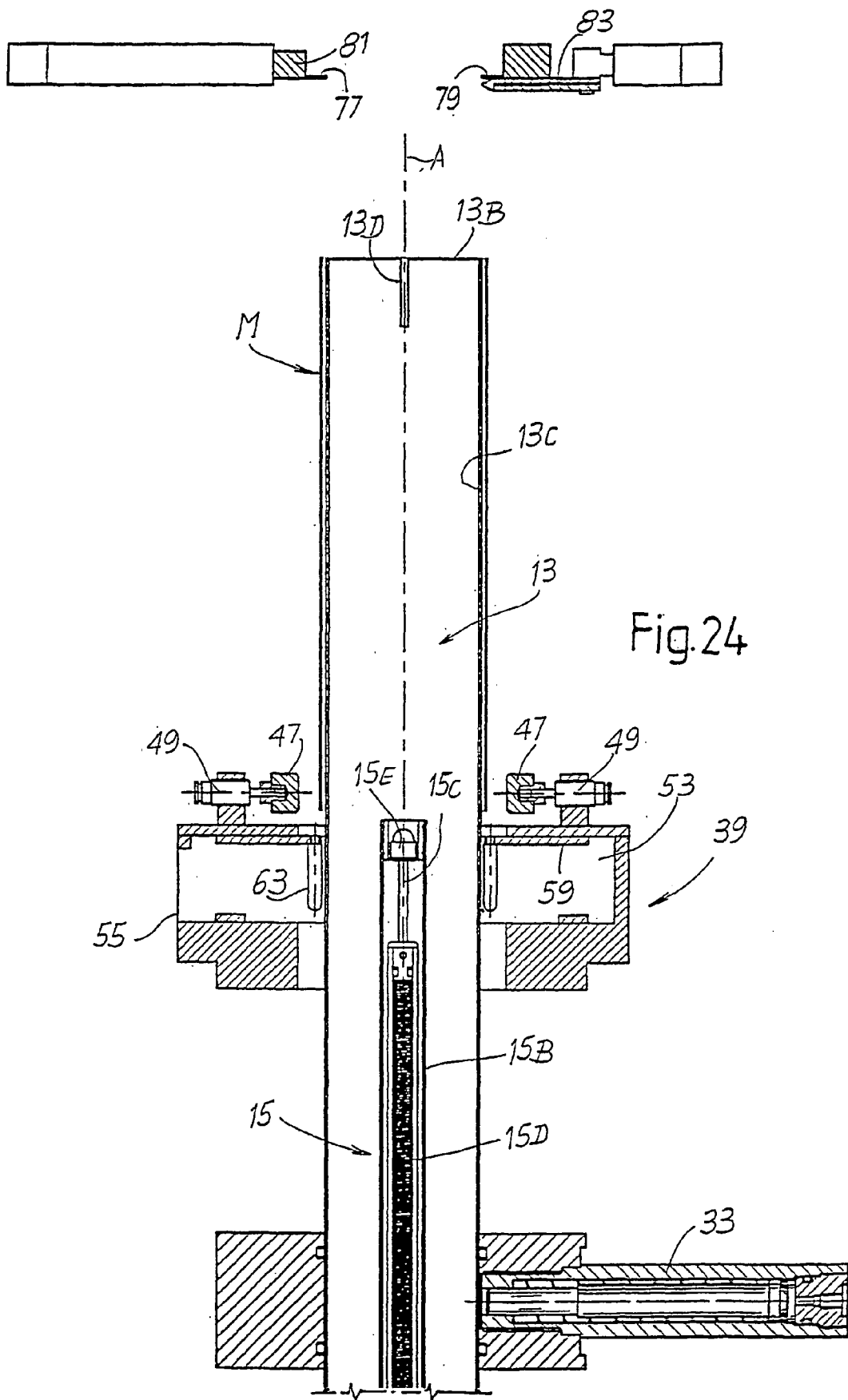
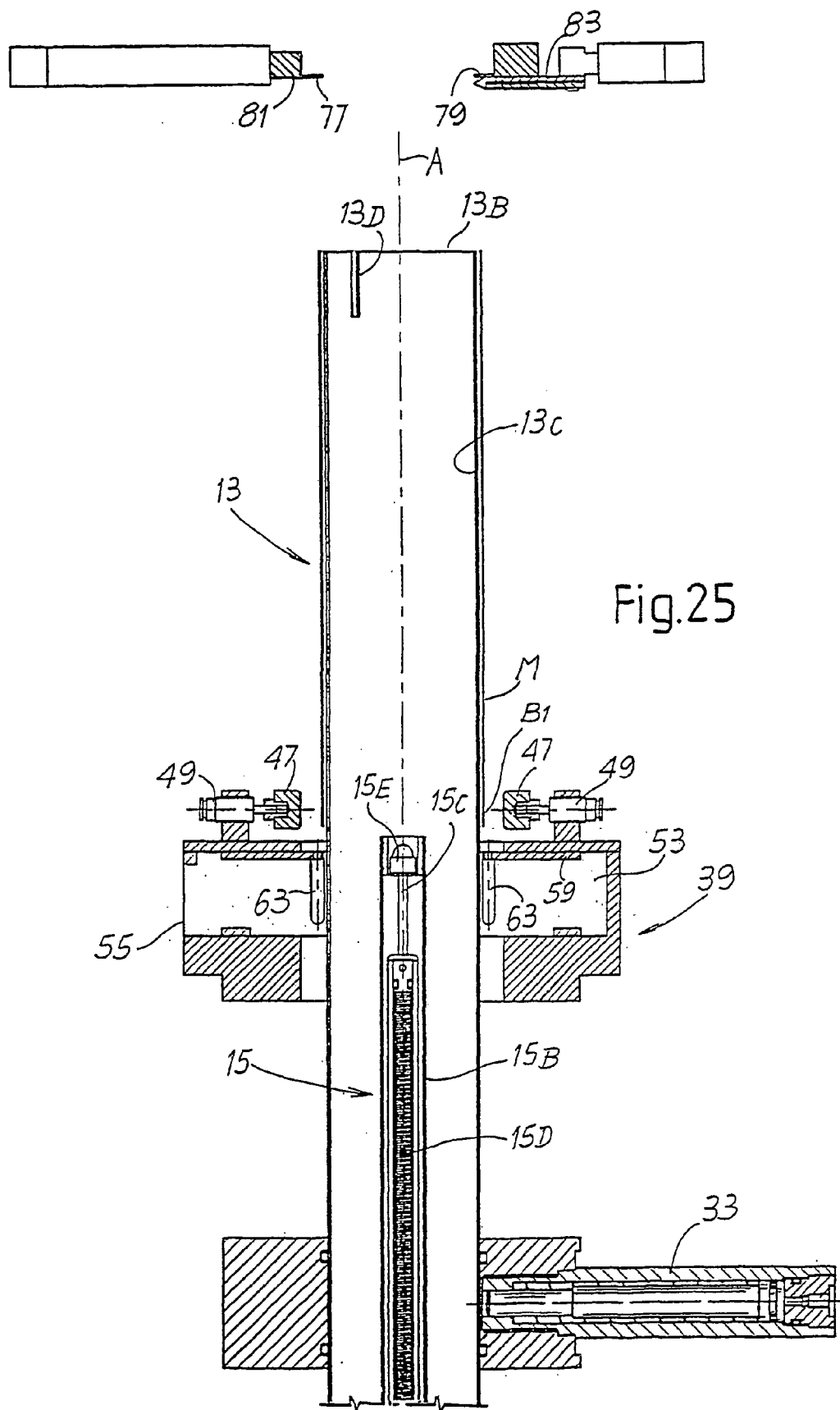

Fig. 23





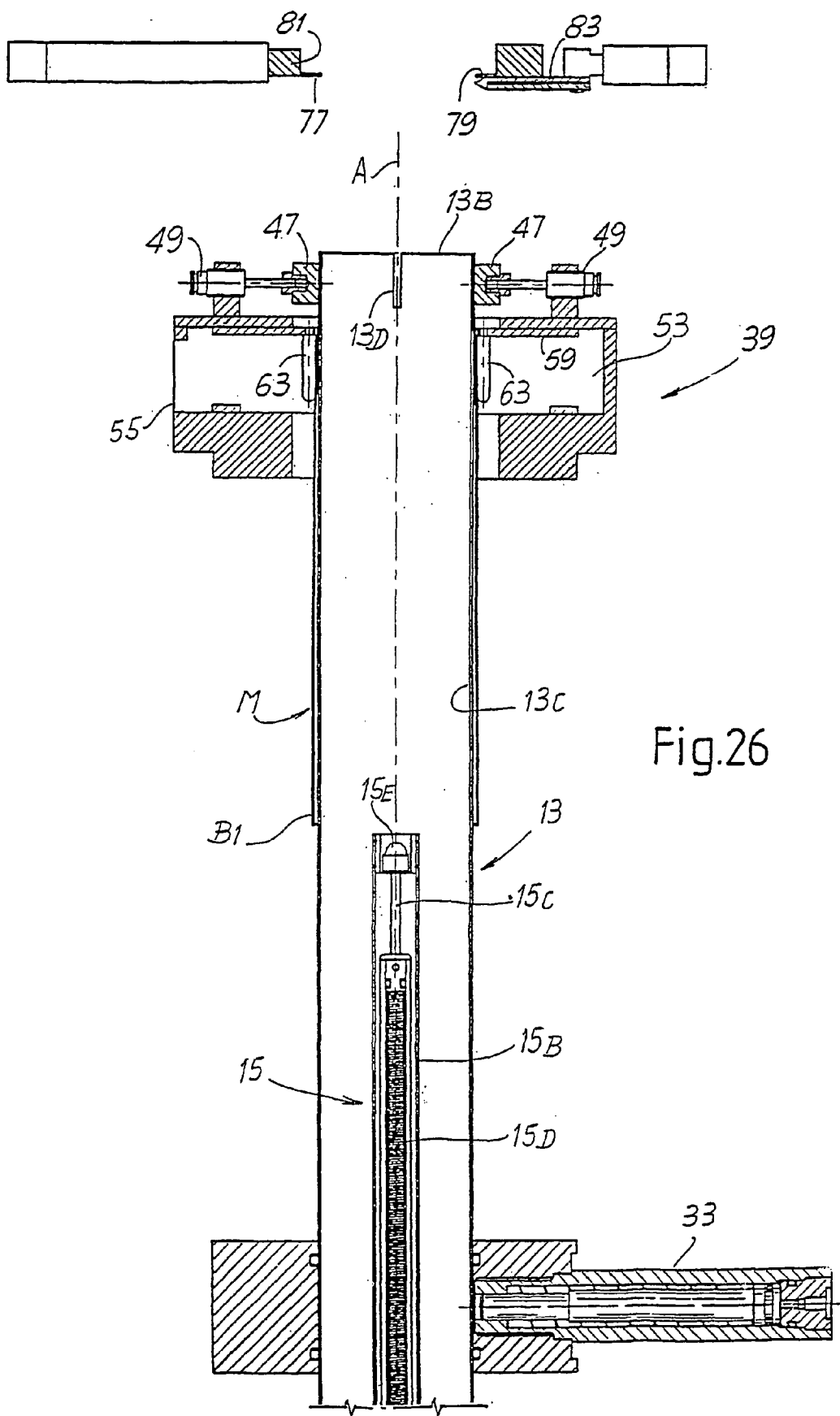
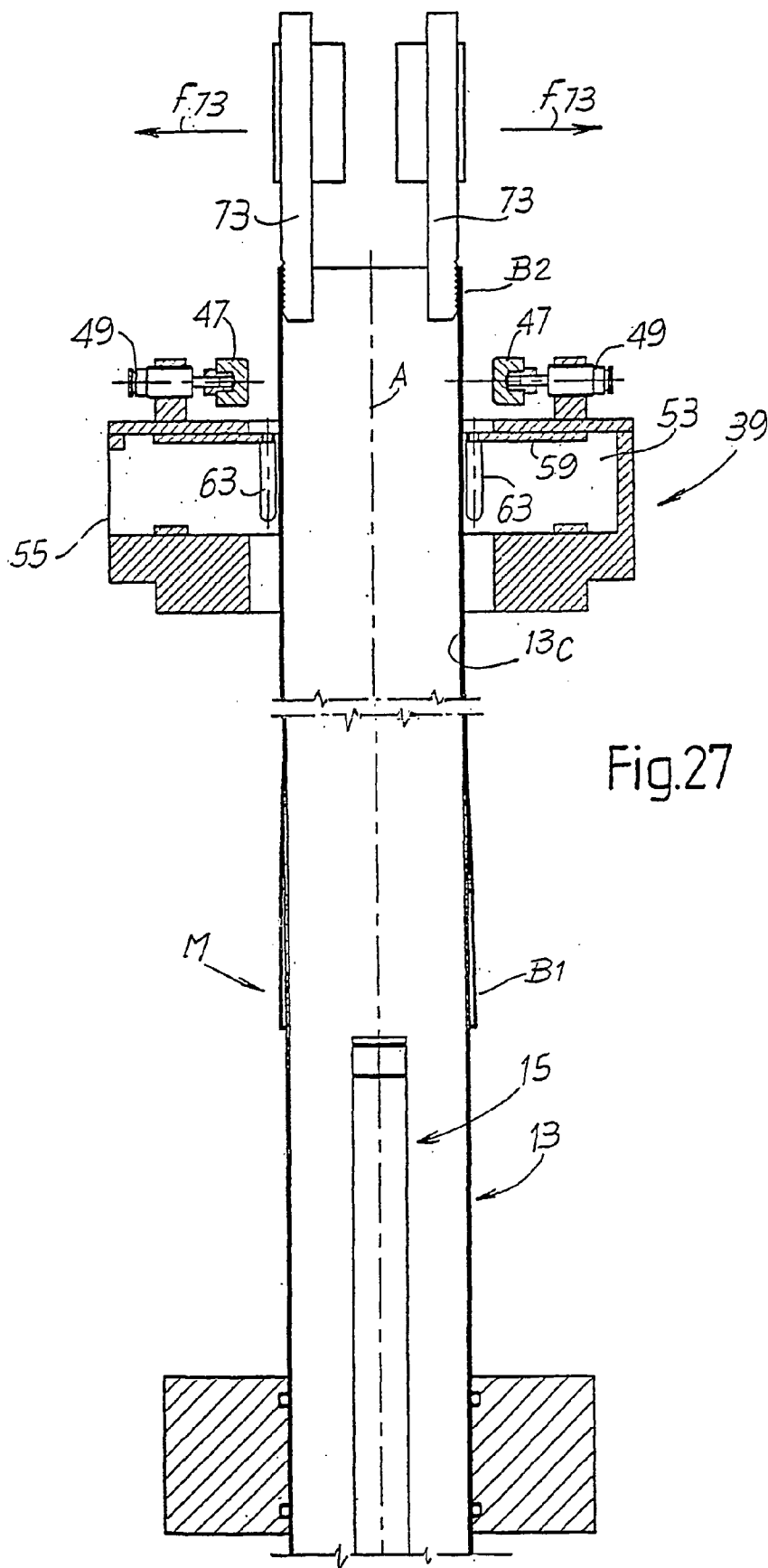

Fig.26



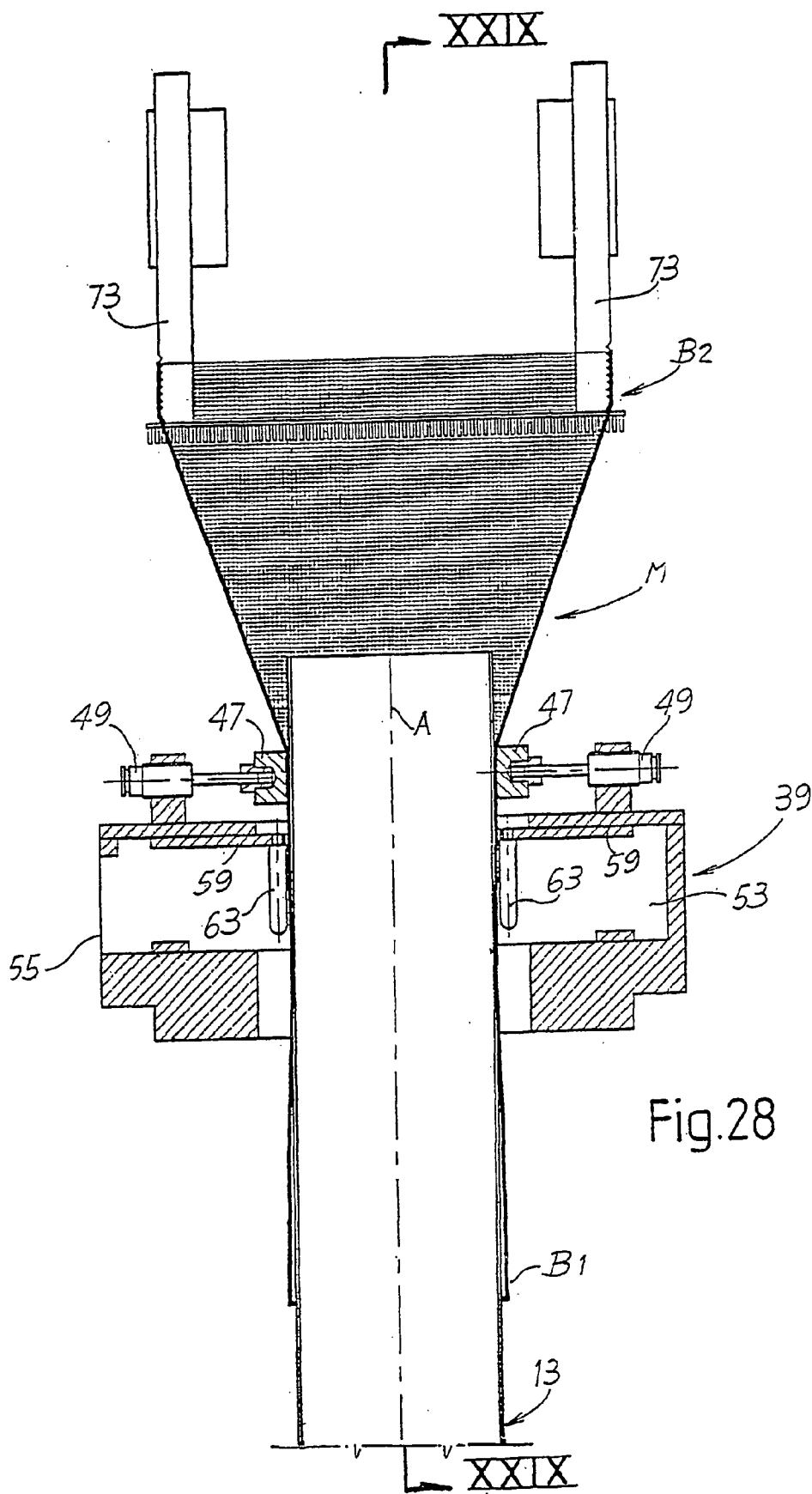
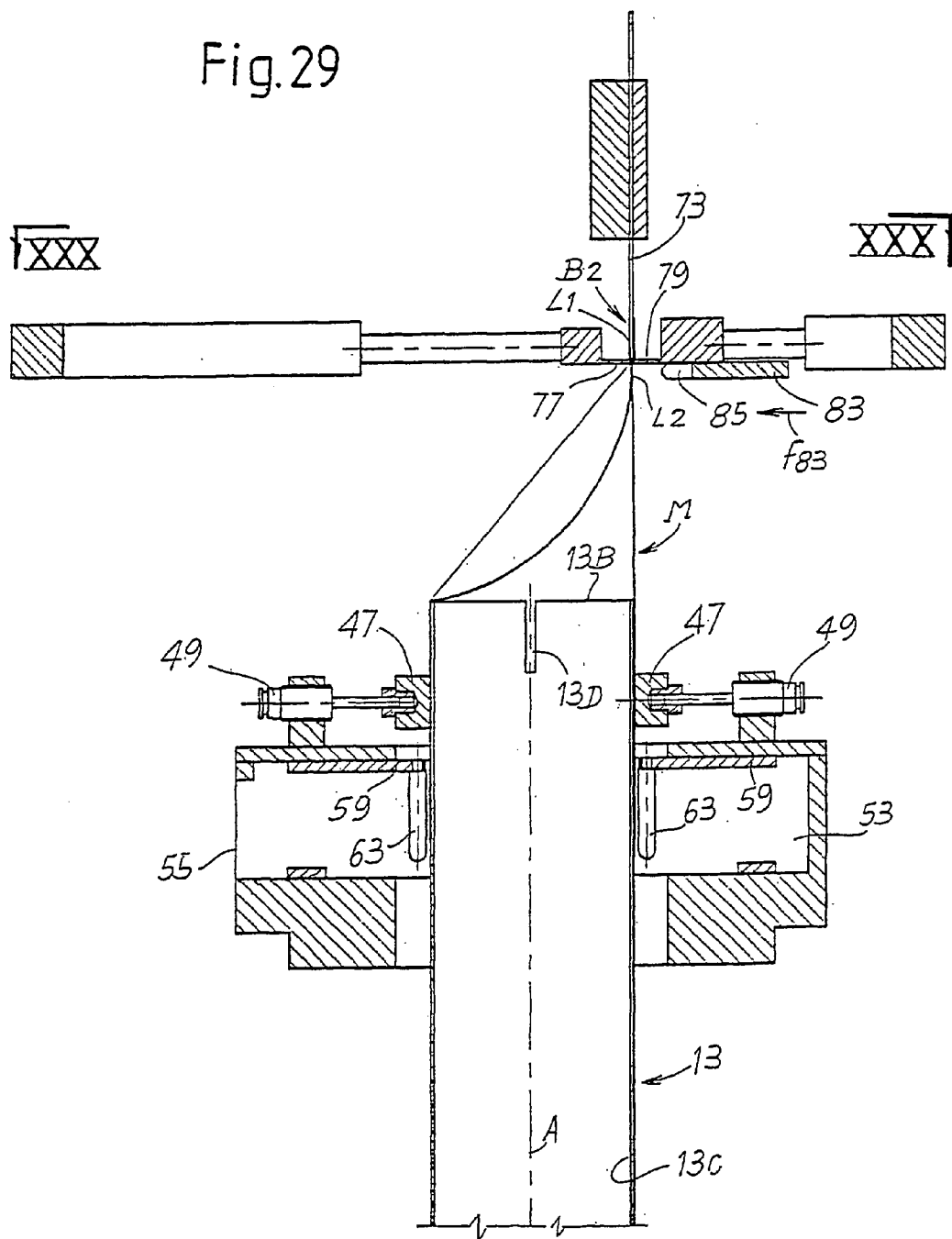

Fig.28

Fig.29



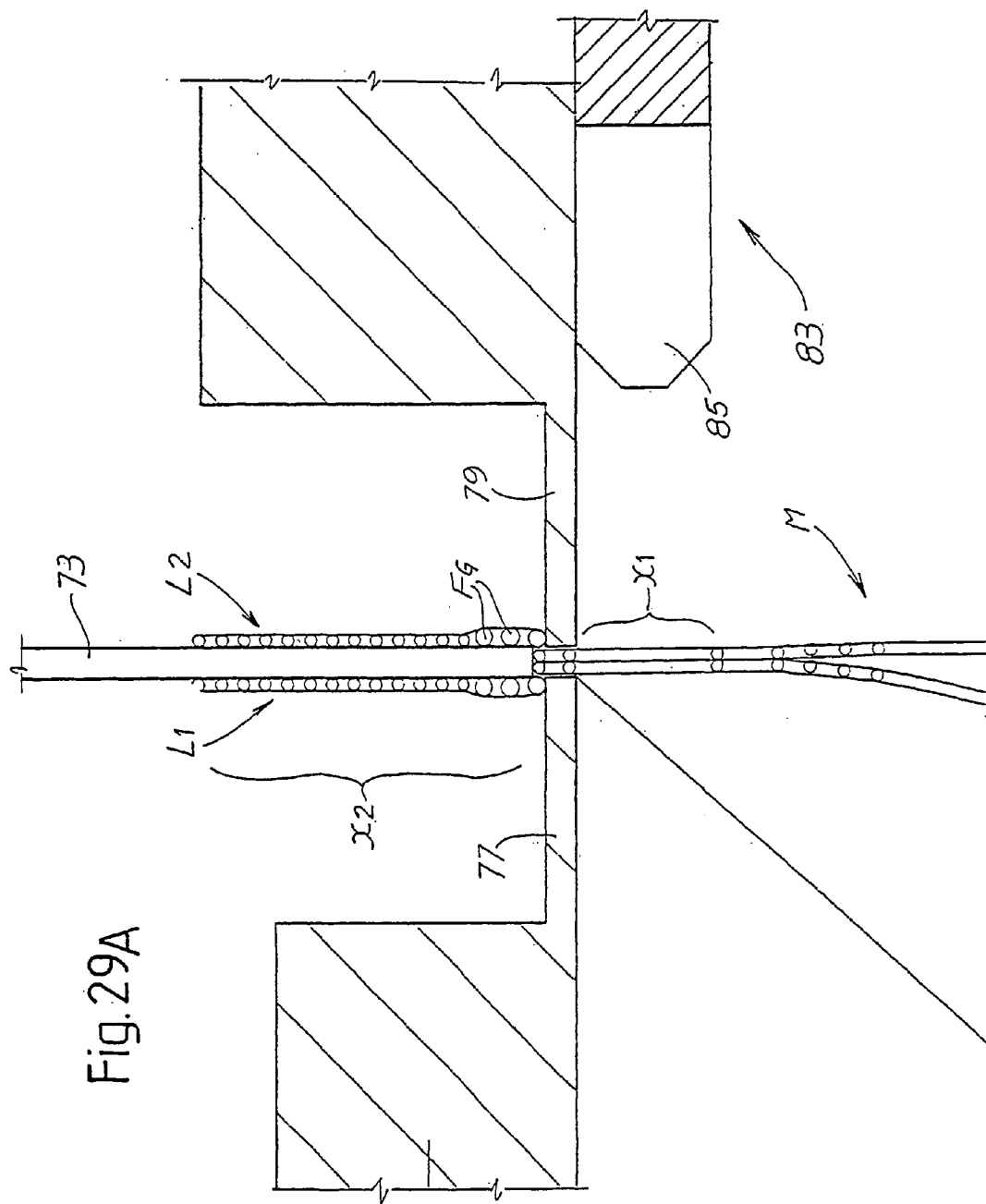

Fig. 29A

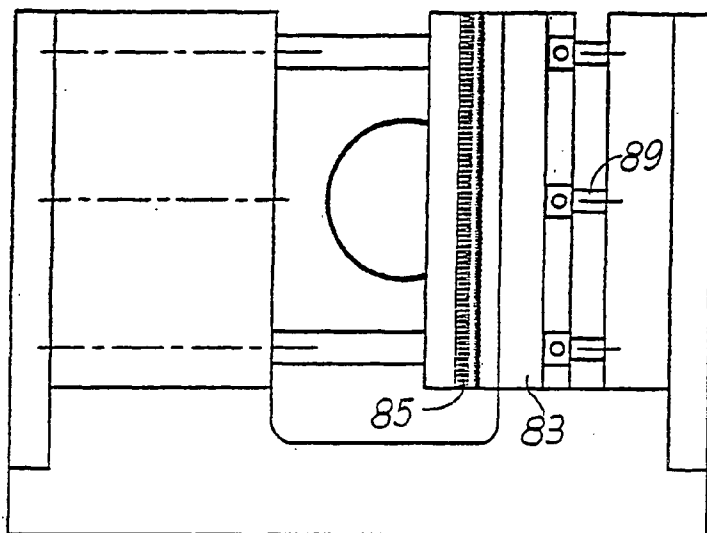

Fig. 32

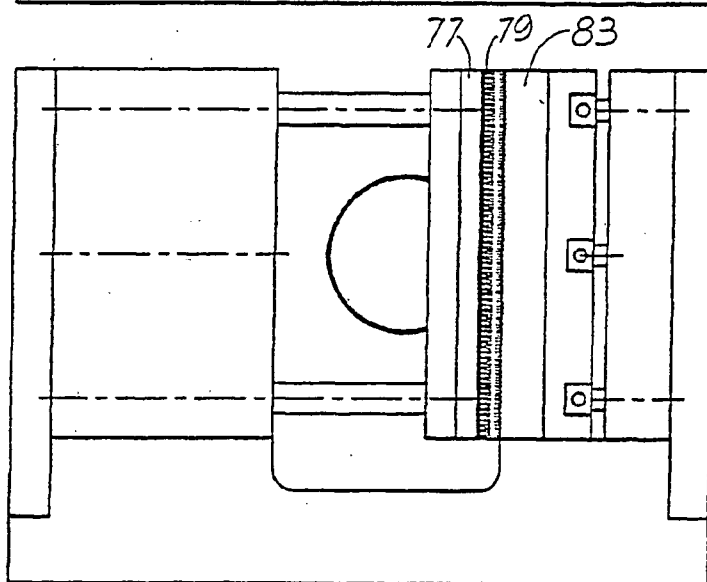

Fig. 31

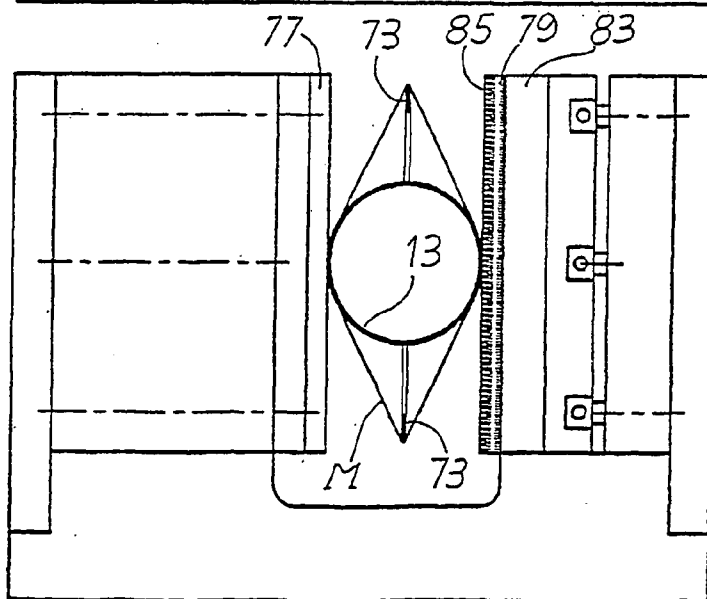

Fig. 30

Fig.34

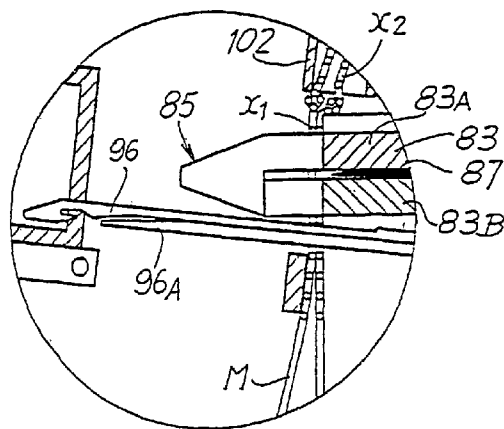
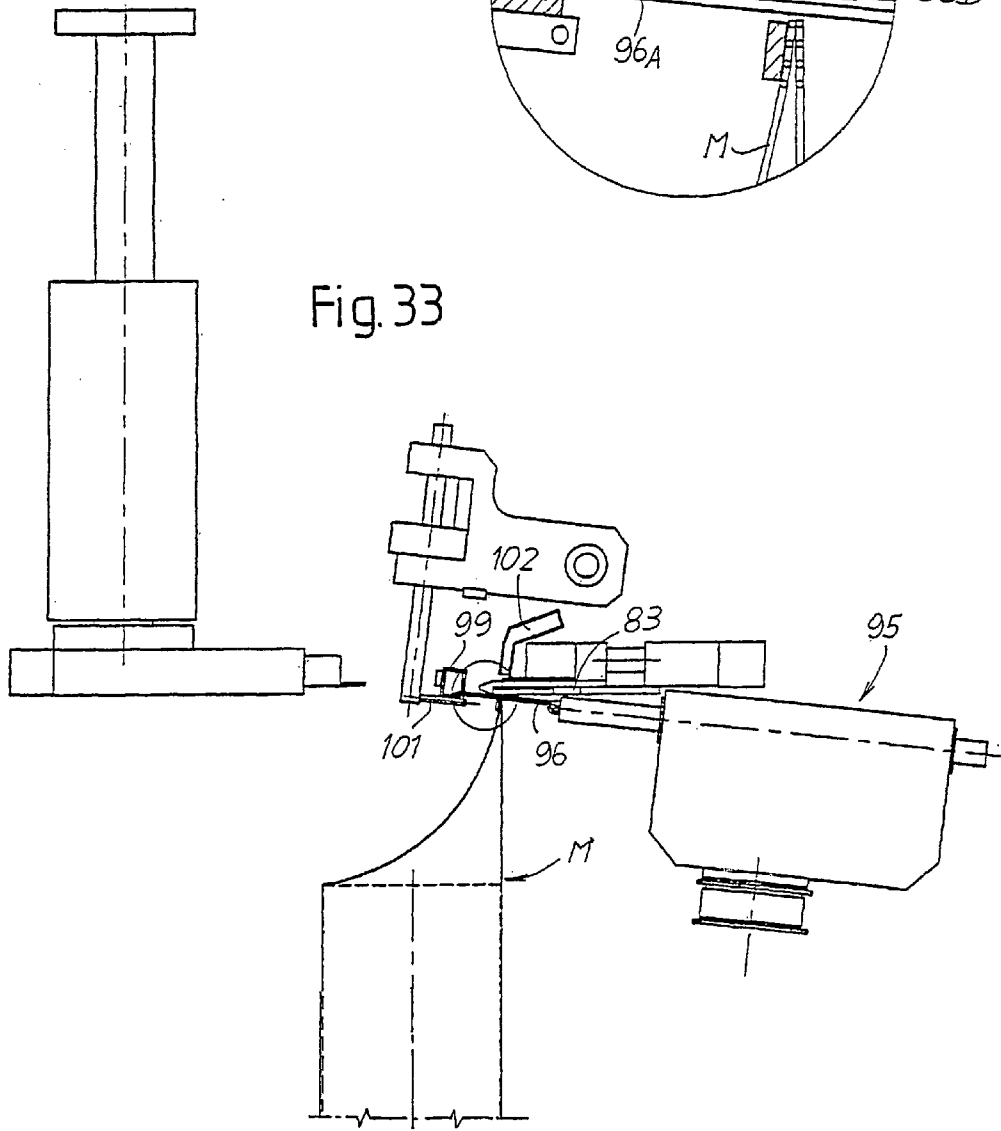

Fig.33



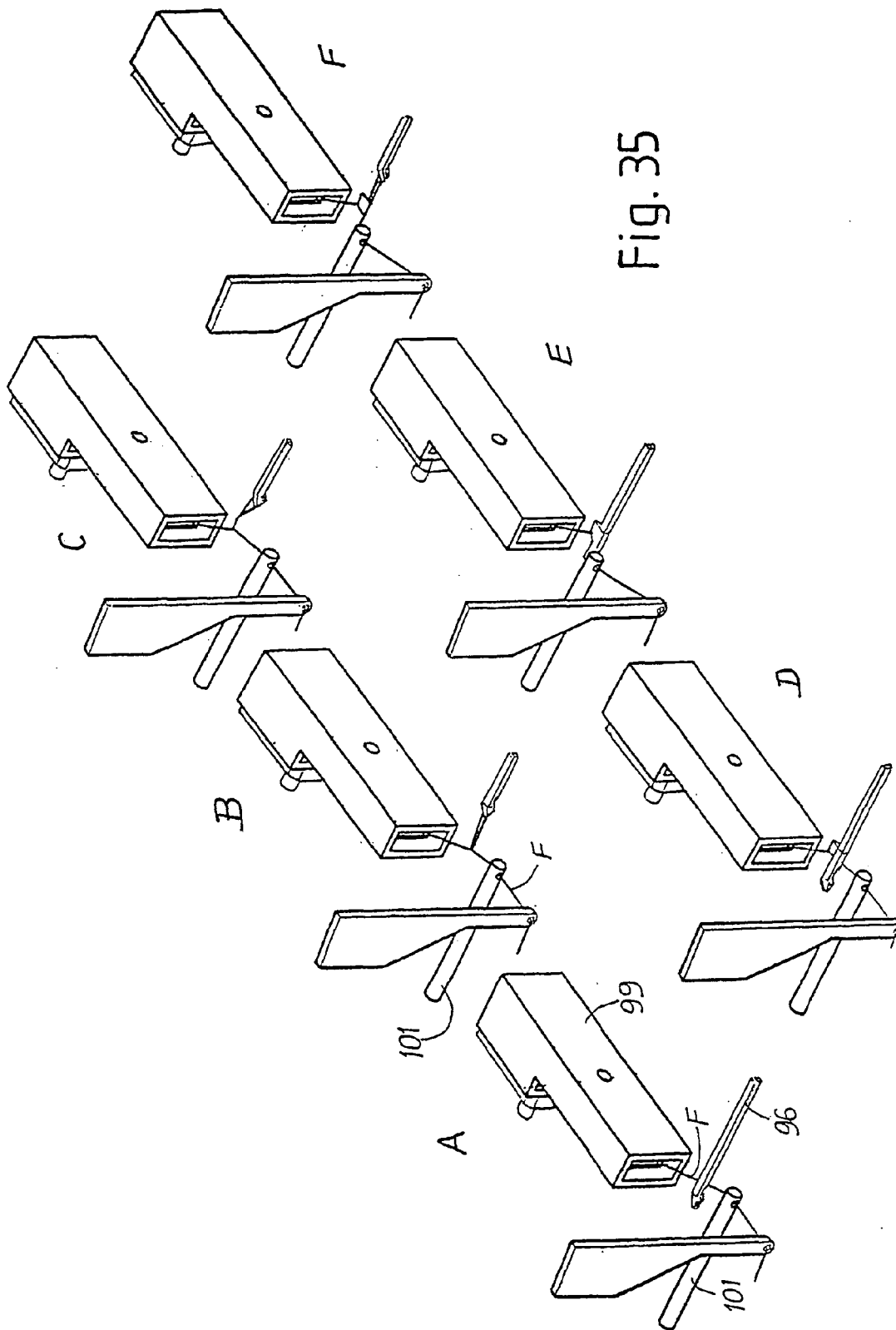

Fig. 35

Fig.36

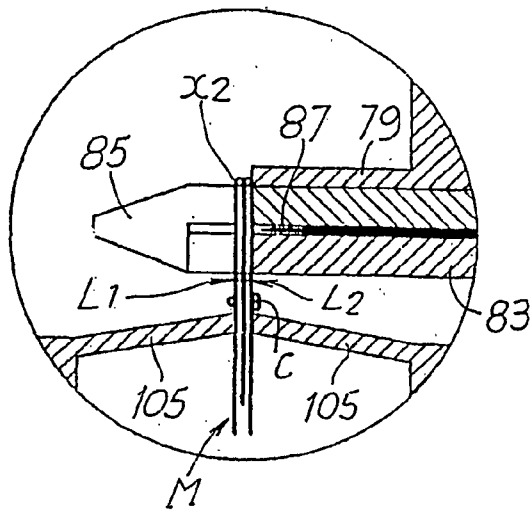

Fig.37

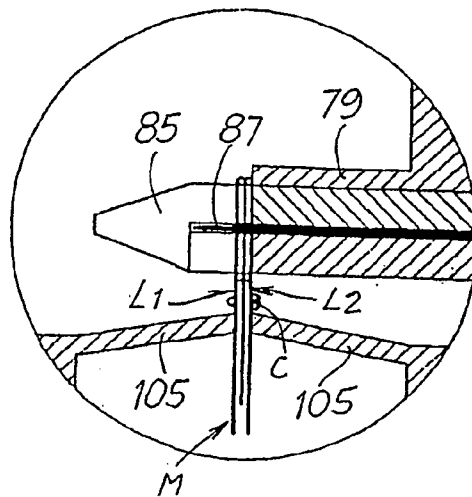

Fig.38

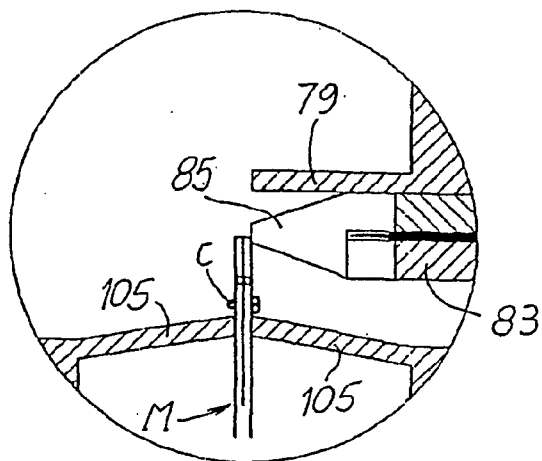
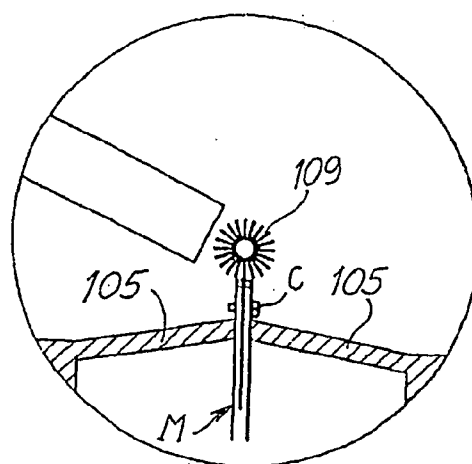
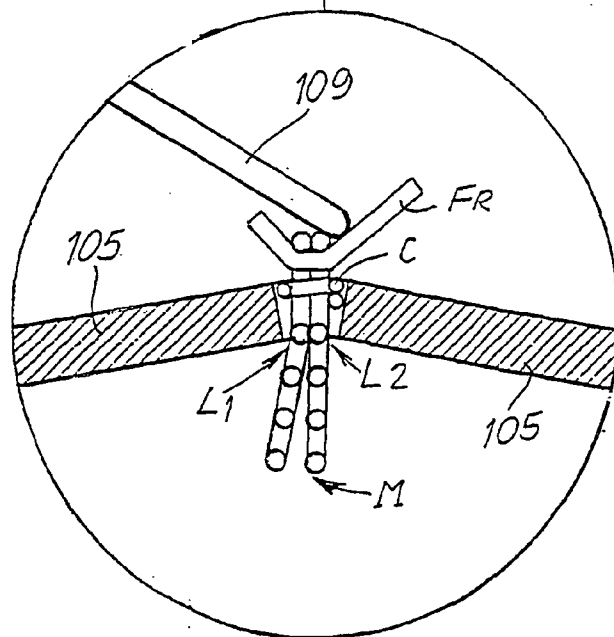
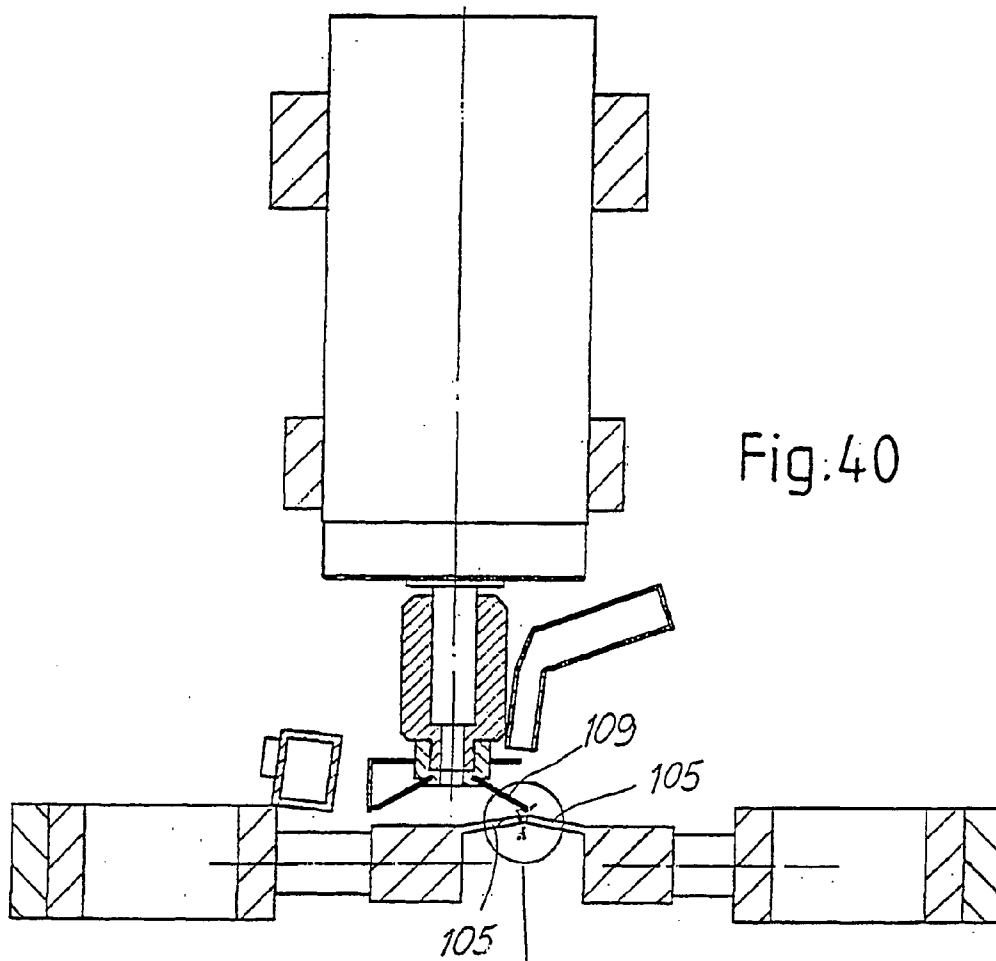
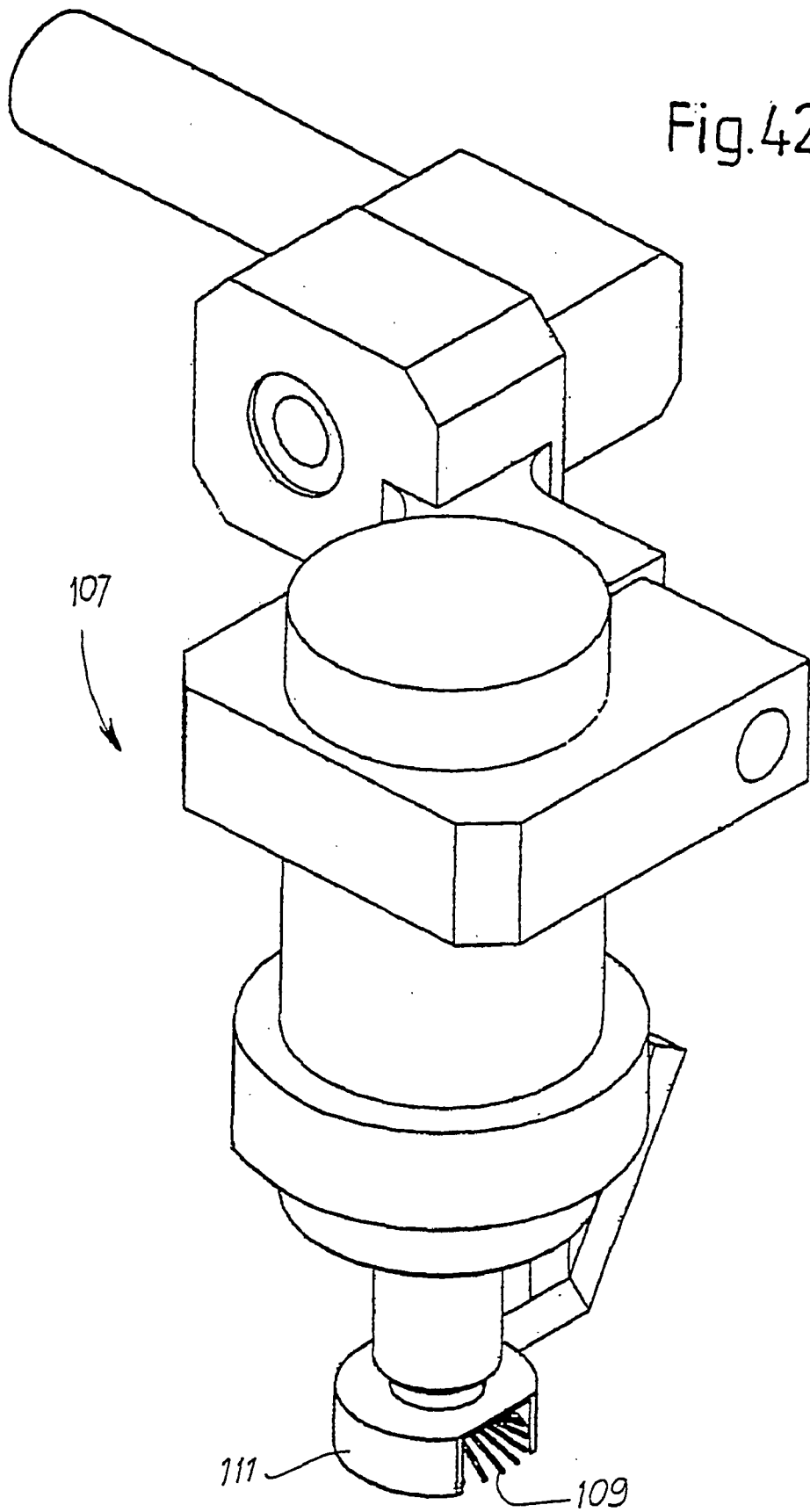

Fig.39







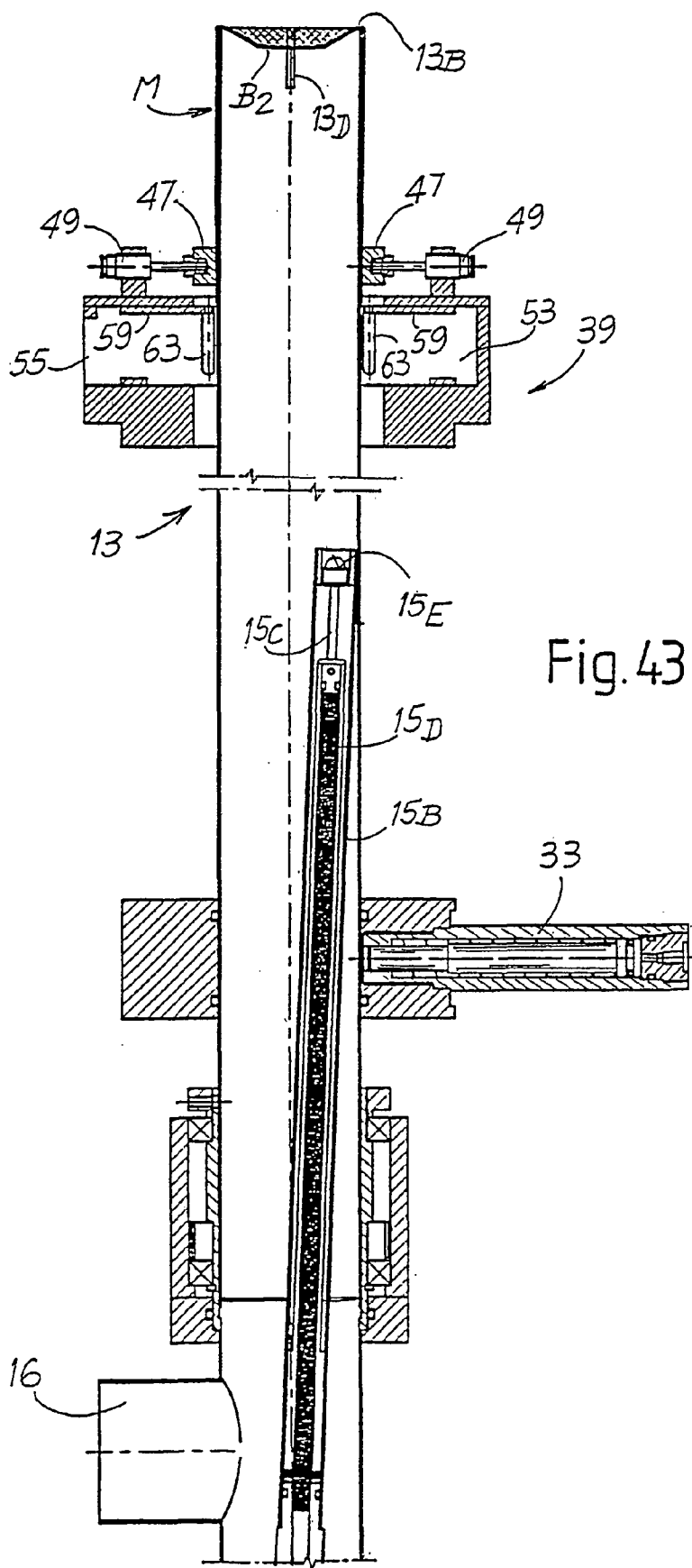

Fig. 43

DEVICE FOR PICKING UP A TUBULAR KNITTED ARTICLE FROM A KNITTING MACHINE AND FOR SEWING THE TOE

TECHNICAL FIELD

[0001] The present invention relates to a device for picking up a knitted article, such as a sock, stocking or the like, from the circular knitting machine that has formed it and for closing the toe of said article with a sewing operation.

STATE OF THE ART

[0002] Many tubular knitted articles, such as socks and stockings, are currently produced on circular knitting machines, namely knitting machines equipped with a cylinder with a circular bed of needles. The article that is obtained has the shape of a tube with an initial edge and an end edge. The latter must be closed, by sewing two opposed flaps, to form the toe of the article. For this purpose, according to the most traditional technique, the tubular article, which is still open, is unloaded from the circular machine that has formed it and is sent on to a different manufacturing department where it is taken up again and it is sewn or undergoes linking.

[0003] In order to simplify the manufacturing process, cut down on labour and in general on production costs, systems and devices have recently been studied that enable sewing of the toe to be obtained in a simpler way, which can easily be automated and in certain cases may be carried out directly on the circular knitting machine that produces the article.

[0004] EP-A-0 592 376 and EP-A-0 635 593 describe circular knitting machines and corresponding knitting methods in which the tubular article is closed at the end of the knitting operation. These machines and methods present the drawback of requiring a particular construction of the machine, with machine accessories and parts that are not normally available and that cannot be inserted into traditional and pre-existing knitting machines.

[0005] EP-A-0 679 746 describes a device for picking up a tubular article from a circular knitting machine in order to carry out subsequent sewing of the toe off the circular machine. The device is complex, in particular as regards the means for picking up and handling the article.

[0006] WO-A-00/01869 describes a device and method for picking up a tubular article from the circular machine that produces it and for closing the toe of the article by sewing. The device described in the above document is particularly advantageous in so far it has a simple, reliable and inexpensive structure. In addition, the method that may be implemented with this known device is fast and consequently enables high production rates to be achieved. However, also this device presents a number of drawbacks deriving from the fact that it must be inserted into the needle cylinder of the circular machine, and consequently in certain cases it requires adaptation of the circular machine, with an increase in the diameter of the needle cylinder. In addition, a sewing machine must be provided underneath the circular knitting machine.

OBJECTS AND SUMMARY OF THE INVENTION

[0007] An object of the present invention is to provide a device of the type specified above that will enable simple

and reliable handling of the tubular article and that can be advantageously designed in such a way that it can be applied to existing circular machines without said machines having to be modified.

[0008] The above and further purposes and advantages, which will clearly appear to persons skilled in the art from the ensuing text, are achieved thanks to a device characterized by a suction pipe that develops from an intake end, in an area where the tubular article is picked up from the circular knitting machine, to an output end, which is located in an area where the toe of the article is sewn, and by an element for guiding the tubular article, which develops inside said suction pipe and extends outside it from the intake end so as to be inserted inside the cylinder of said circular knitting machine, there being provided, between the guide element and the inner wall of the suction pipe, a space for transit of the tubular article.

[0009] With the above arrangement, the tubular article is formed by the circular bed of needles around the guide element, which may be made even with a relatively modest cross section and hence may be inserted into a needle cylinder of the size currently used in knitting machines for the production of hosiery articles. The tubular article that has been formed is sucked inside the duct and is guided along the latter by the guide element until it reaches the output end of the suction pipe, to which a system is associated for extraction of the tubular article from the suction pipe and for turning the article inside out onto the outside of the suction pipe.

[0010] According to a particularly advantageous embodiment of the invention, the suction pipe is internally divided into two consecutive portions by an openable intermediate separator. The latter also has the function of supporting the guide element. When the intermediate separator is opened to enable passage of the tubular article, the guide element is temporarily supported by appropriate supporting means that can move in such a way as to enable passage of the tubular article inside the space between the inner surface of the suction pipe and the guide element.

[0011] According to a particularly advantageous embodiment of the invention, the guide element may have a telescopically extensible portion which can extend towards the output end of the suction pipe. Said telescopically extensible portion is extended as far as the output end of the suction pipe when the tubular article is to reach the sewing means associated to the output end, and is then retracted to facilitate discharge of the tubular article after closing of the toe. In this case, discharge may, take place by suction in the reverse direction inside the suction pipe.

[0012] In order to facilitate discharge of the tubular article, it is possible to envisage that the guide element should be made up of two parts hinged together about an axis orthogonal to the axis of the suction pipe, in such a way that the guide element will be able to come up to the inner wall of the suction pipe to enable passage of the tubular article that has been sewn.

[0013] According to an embodiment of the invention, the system for extracting the tubular article from the suction pipe may comprise:

[0014] widening members for widening the tubular article at the initial edge of the article itself, said

widening members causing widening of the initial edge of the tubular article beyond the outer diameter of the suction pipe; and

[0015] members for turning the tubular article inside out, from the inside of the suction pipe to the outside.

[0016] The widening members may comprise a plurality of stems which are roughly parallel to the axis of the suction pipe and are provided with a motion of approach to and recession from the axis of the suction pipe so as to assume a position close to the axis of the suction pipe and a position outside the diameter of the suction pipe, said stems being axially mobile along the outside of the suction pipe.

[0017] It is also possible to envisage that the stems should be carried each by a plate roughly orthogonal to the axis of the suction pipe. In this way, when the stems are in the position close to the axis of the suction pipe, the plates form a contrast wall for arrest of the tubular article that is being conveyed inside said suction pipe. This renders the configuration of the device particularly, simple, even though the possibility is not ruled out of separating the stems from the plates and controlling the latter separately from and independently of the stems.

[0018] The members for turning the article inside out may comprise, for example, radial pushers that are mobile radially and axially with respect to said suction pipe and outside the latter to press the tubular article against the outer surface of the suction pipe and draw it along said outer surface.

[0019] The invention also relates to a circular knitting machine comprising a device of the type described above.

[0020] Further advantageous characteristics of the device according to the invention are specified in the attached claims and will be described in greater detail hereinafter with reference to a non-limiting example of embodiment of the invention.

BRIEF DESCRIPTION OF THE DRAWINGS

[0021] A better understanding of the present invention will be provided by the ensuing description and by the attached drawings, which illustrate a non-limiting example of embodiment of the invention. In greater detail, in the drawings:

[0022] FIG. 1 is a perspective view of a device for picking up a tubular knitted article from a cylinder of a circular knitting machine and of a device for sewing the toe of the article;

[0023] FIG. 2 is a side view according to the line II-II of FIG. 1;

[0024] FIG. 3 is a view according to the line III-III of FIG. 2;

[0025] FIG. 4 is a perspective view of the devices combined with a circular knitting machine;

[0026] FIG. 5 is a perspective view of one part of the sewing area, with elements removed for reasons of greater clarity of the drawing;

[0027] FIG. 6 is similar to FIG. 5 and shows the same members from a different observation point;

[0028] FIG. 7 is a perspective view of the sewing machine for closing the toes of tubular articles picked up by the pick-up device;

[0029] FIG. 8 is a perspective view of an intermediate separator set along a suction pipe of the pick-up device;

[0030] FIG. 9 shows the internal members of the intermediate separator of FIG. 8;

[0031] FIG. 10 is a longitudinal cross-sectional view of the intermediate separator;

[0032] FIG. 11 shows a mobile axial unit that carries the widening members and the members for turning the tubular article inside out for preparing it for sewing of the toe;

[0033] FIG. 12 shows the same unit as FIG. 11 with parts removed;

[0034] FIG. 13 is a longitudinal cross-sectional view of the unit of FIGS. 11 and 12;

[0035] FIG. 14 is a view from below according to the line XIV-XIV of FIG. 13;

[0036] FIG. 15 shows a pair of bars for retention of the article during the initial steps of sewing of the toe;

[0037] FIG. 16 shows a comb-like structure for engagement of the article during sewing and a cutting member housed inside the comb-like structure;

[0038] FIGS. 17 to 28 show, in a cross-sectional plane passing through the axis of the suction pipe, the device for picking up the article (or part of the device), as well as the widening members and the members for turning the article inside out in order to prepare it for sewing of the toe, FIG. 17A being an enlargement of the output area of the suction pipe;

[0039] FIG. 29 is a cross-sectional view according to the line XXIX-XXIX of FIG. 28;

[0040] FIG. 29A is an enlargement of the central area of FIG. 29;

[0041] FIGS. 30 to 32 are cross-sectional views, according to the line XXX-XXX of FIG. 29, of the pair of bars for retention of the article and of the comb-like structure in the step of engagement of the article and insertion of the comb-like structure into the respective row of stitches, as a preliminary step to sewing of the toe;

[0042] FIG. 33 shows the sewing machine and the comb-like structure inserted in the article during sewing;

[0043] FIG. 34 is an enlargement of a detail of FIG. 33;

[0044] FIG. 35 is a schematic illustration of the action of the needle of the sewing machine during the sewing operation;

[0045] FIGS. 36 to 39 show the steps for cutting the loops of the row of the tubular article inside which the comb-like structure has been inserted;

[0046] FIG. 40 shows the step of removal of the residue of yarn after cutting of the loops adjacent to the sewing row;

[0047] FIG. 41 illustrates a detail of FIG. 40;

[0048] FIG. 42 is a perspective view illustrating a possible embodiment of the system for removal of the residue of yarn; and

[0049] FIG. 43 is an axial sectional view of the end portion of the suction pipe in the step of removal of the tubular article after the sewing operation;

DETAILED DESCRIPTION OF THE PREFERRED EMBODIMENT OF THE INVENTION

[0050] The devices for picking up and sewing tubular articles are shown in FIG. 4 in combination with a circular knitting machine, and in isolation from the knitting machine in FIGS. 1 to 3. The internal structure of the pick-up device may be seen in FIGS. 17 to 28. In some of the figures, parts of the devices have been removed for greater clarity of representation. In what follows generic reference will frequently be made to the ensemble made up of the pick-up device and sewing device as to a single device for picking up the article and closing the toe, it being, however, understood that the pick-up device may be combined with a different device for closing the toe and vice versa.

[0051] In the attached drawings, the device for picking up the tubular article and closing the toe is designated, as a whole, by 1, whilst 3 designates, as a whole, the circular knitting machine that produces the tubular article. Of the circular knitting machine 3, only the essential components are indicated, which may be seen in particular in FIGS. 17 to 19, which show the cylinder 5 of the needles 7 that form a circular needle bed, in a way in itself known. The needle cylinder 5 is supported, in such a way that it can turn about its own axis, by means of a support, designated by 9, and is set in rotation by means of members (not illustrated) which mesh with a crown gear 11. The members for controlling the needles 7 of the circular bed are not shown, but are in themselves known, as are also all the other members of the circular knitting machine 3, which consequently will not be described in any further detail herein.

[0052] The device 1 comprises a suction pipe 13, which is substantially U-shaped, and one end of which, designated by 13A, will hereinafter be referred to as intake end, whilst one end, designated by 13B, will hereinafter be referred to as output end. The intake end 13A is set underneath the cylinder 5 of the needles 7 of the knitting machine 3. In this way, the suction pipe 13 may have any diameter whatsoever, which is independent of the, internal diameter of the cylinder 5.

[0053] Inside the suction pipe 13 there develops a guide element, designated as a whole by 15. Said guide element 15 (which in the example illustrated has a substantially tubular conformation with a circular cross section) extends outside the suction pipe 13 from the intake end 13A as far as inside the cylinder 5 of the needles 7 of the knitting machine 3. The top end of the guide element 15 approximately reaches the plane of formation of the knitted fabric of the knitting machine 3.

[0054] The guide element 15 is made up of two parts, one of which is designated by 15A and the other by 15B. These two parts are hinged about an axis of trace 17 (see in particular FIG. 17) orthogonal to the axis (namely, to the median line) of the suction pipe 13 and of the guide element

15 itself. The reason for this configuration will appear more clearly from the ensuing description of the operation of discharge of the article with the toe closed.

[0055] The guide element 15 is supported, inside the suction pipe 13, by means of an intermediate separator, which is designated as a whole by 19, and the parts of which are illustrated in detail in FIGS. 8 to 10. The intermediate separator 19 also performs the function of dividing the suction pipe 13 into two consecutive parts, the first of which develops between the intake end 13A and the intermediate separator 19, and the second between the latter and the output end 13B.

[0056] As may be seen in detail in FIGS. 8 to 10, the intermediate separator 19 is made up of a pair of jaws 21 and 22 operated by respective actuators 23 and 24, which, in the example illustrated, consist of cylinder-piston systems. The jaws 21 and 22 are fixed to the stems of the cylinder-piston actuators 23 and 24 and have V-shaped front profiles, designated by 21V and 22V. The jaw 21 has a slot, inside which the front portion of the jaw 22 penetrates in such a way as to grip, between the two profiles 21V and 22V, the guide element 15, withholding it in a coaxial position, namely centred with respect to the suction pipe 13.

[0057] The jaws 21 and 22 slide in a guide frame 25 which is fixed to the suction pipe 13.

[0058] As may be seen in FIGS. 9 and 10 (in the latter figure the jaws 21 and 22 being shown in the closed condition), the jaw 22 has an internal duct, designated by 27, which opens onto the profile 22V and onto the top portion of the jaw itself (see in particular FIG. 9). The frame 25 has a slotted opening 29 in a position corresponding to the outlet area of the internal duct 27 to enable application of a flexible pipe or hose that connects the internal duct 27 to a source of air under pressure (not shown) for the purposes that will be clarified in what follows.

[0059] As may be seen in particular in FIGS. 17, 18 and 19, the guide element 15 has (in its part 15B) a hollow structure inside which a stem 15C is housed that terminates with a head 15E (see in particular FIG. 17A), said stem constituting a telescopically extensible portion of the guide element itself. The reference number 15D designates an extension spring that forces the stem 15C to return into the hollow tubular part of the guide element. The air under pressure, which can be supplied through the internal duct 27 of the jaw 22, has the function of pressurizing the internal area of the hollow part 15B of the guide element 15 to overcome the force of the extension spring 15D and to extract the stem 15C until it reaches the position illustrated in FIGS. 17 to 19, whilst in FIG. 20 the stem 15C is shown in a retracted position inside the hollow part of the guide element 15.

[0060] Since the jaws 21 and 22 of the intermediate separator 19 can open, thus releasing the guide element 15 in order to enable passage of the tubular article which must pass along the suction pipe 13 (as will be clarified in what follows), along the suction pipe 13 there are provided further systems for temporary support of the guide element 15 inside the suction pipe 13. These supporting means are clearly visible in FIGS. 1, 2 and 3 and are represented in a simplified way in the remaining figures. They are made up of three sets of sliders 31, 32, 33 positioned in respective

three sections set at distances apart along the development of the suction pipe 13. In greater detail, two sets of three sliders, namely the sets of three sliders 31 and 32, are positioned on planes orthogonal to the axis of the suction pipe between the intake end 13A of the suction pipe and the intermediate separator 19. The last set of sliders 33 is positioned on a plane between the intermediate separator 19 and the output end 13B of the suction pipe 13. The sets of sliders 31, 32 and 33 can be brought back or retracted in such a way that they do not project inside the suction pipe 13, so as to leave completely free the space between the inner wall of the suction pipe 13 and the guide element is. Alternatively, the sliders of each set can be displaced radially inwards in such a way that they engage the guide element 15, supporting it inside the suction pipe 13. Synchronized actuation of the sets of sliders 31, 32, 33 enables (in the way that will be clarified hereinafter) transit of the tubular article discharged from the circular needle bed 37 along the suction pipe 13 towards the output end 13B of the latter.

[0061] The suction pipe 13 has an end part 13C which is angularly mobile about its own axis with respect to the remaining part of the suction pipe. The movement of rotation of the end part 13C of the suction pipe 13 is imparted by an actuator 35, for example a stepper motor. The latter enables adjustment of the angular position of the part 13C of the suction pipe 13 with respect to the remaining part (which is fixed on the supporting structure) of the pipe, in order to orient appropriately the tubular article before sewing of the toe of the latter, as will emerge clearly from the detailed description of the modes of operation of the entire device.

[0062] At the output end 13B of the suction pipe 13 there is provided a sewing area, designated as a whole by 37. Located in this area are the members that have the function of extracting the tubular article, turning it inside out, from inside the suction pipe 13, of closing the toe of said article by sewing and re-inserting the article into the suction pipe 13 so as to discharge it finally from the device.

[0063] Set in the sewing area 37 is a unit 39 which surrounds the suction pipe 13, and more precisely the portion 13C of the latter. The unit 39 carries, in a way that will be described in detail with reference to FIGS. 11 to 14, the widening members and the members for turning the tubular article inside out before it is sewn. The unit 39 is axially mobile, in the direction indicated by the arrow f39, along the end part 13C of the suction pipe 13. For this purpose, there are provided a slide guide 41 and an actuator 43 which controls movement of the unit 39.

[0064] The unit 39 is illustrated in detail in a perspective view in FIGS. 11 and 12, in a cross-sectional view in FIG. 13, and in a view from below in FIG. 14. FIG. 11 shows a ring 45 which forms part of the unit 39 and which is coaxial with the axis of the part 13C of the suction pipe 13. The ring 45 supports a plurality of radial pushers 47 constituting the members for turning the tubular article inside out before sewing of the toe. Each pusher 47 is provided with a radial movement controlled by a corresponding actuator 49, for example a small cylinder-piston actuator. Beneath the ring 45, the unit 39 has a wall 51 which delimits an internal suction chamber 53. The latter is connected, through an opening 55, to a suction line, the connection of which to the suction chamber 53 is designated by 57.

[0065] Set inside the suction chamber 53 present in the unit 39 are five shaped plates 59 supported by rotating

spindles 61. Each shaped plate 59 carries, in a position at a distance from the corresponding supporting spindle 61, a stem 63 parallel to the spindle 61 itself. The conformation of the shaped plates 59 is such that (see in particular FIG. 12, in which the overlying pushers 47, their actuators 49 and the ring 45 have been removed for clarity of representation), in a first angular position of the spindles 61, they form a substantially continuous wall orthogonal to the axis of the suction pipe 13, or more exactly to the end part 13C of the suction pipe 13. The wall formed by the shaped plates 59 has a central hole 65 for the purposes that will be clarified hereinafter.

[0066] The shaped plates 59 are controlled in such a way that they open simultaneously by means of an oscillation of each spindle 61 about its own axis. For this purpose, a mechanism is provided, which is shown in FIGS. 13 and 14 and which comprises pinions 67 fixed to the bottom end of each spindle 61 and meshing with an internal-toothed crown gear 69, the rotation of which causes spontaneous rotation of the pinions 67 and thus of the spindles 61. Rotation of the toothed crown gear 69 is obtained by means of a pinion 70 fitted on a shaft 72 which is driven in rotation about its own axis by means of a cylinder-piston actuator 74.

[0067] Set above the unit 39, and approximately aligned with the end part 13C of the suction pipe 13, is a gripping member, designated as a whole by 71, for gripping the tubular article that is to be sewn. The gripping member comprises a pair of brackets 73 (see in particular FIGS. 1 to 3 and 5 and 6) which are mobile with respect to one another with a movement of approach and recession represented by the double-headed arrow f73 (see in particular FIGS. 5 and 6). Movement in the direction indicated by the arrow f73 is obtained by a pair of cylinder-piston actuators associated to the brackets 73 and carried by a structure which is in turn provided with movements according to a horizontal axis X and a vertical axis Y (see again in particular FIGS. 5 and 6). As will emerge clearly hereinafter, the brackets 73 can be brought up to one another for penetrating inside the suction pipe 13 and gripping the end edge of the tubular article, and then tensioning it and carrying it to the sewing machine for the subsequent sewing operation.

[0068] The structure that carries the member 71 for gripping the tubular article is supported by a base structure 75, which is in turn constrained to a fixed frame, for example the frame itself of the knitting machine 3. The base structure 75 carries a pair of bars 77 and 79 which are roughly rectilinear. The bar 77 is fixed to a portion of metal section 81 which is mobile, as indicated by the double-headed arrow f81, by means of cylinder-piston actuators (not shown). In this way, the bar 77 can move away from and up to the bar 79, which is, instead, fixed with respect to the base plate 75.

[0069] Underneath the fixed rectilinear bar 79, a comb-like structure 83 is provided, which is illustrated in isolation and in detail in FIG. 16. The comb-like structure 83 has a plurality of teeth 85 and is made up of two portions 83A and 83B, which are connected together and define an intermediate seat for sliding of a cutting blade 87. The comb-like structure 83 is mobile as indicated by the double-headed arrow f83 (see in particular FIG. 6) in a direction orthogonal to the longitudinal development of the fixed rectilinear bar 79. The cutting blade 87 housed inside the comb-like structure 83 moves together with the comb-like structure 83,

following the movement of the latter as indicated by the arrow f83. The movement is obtained by cylinder-piston actuators or equivalent actuators, designated by 89 in FIG. 6.

[0070] As may be seen in particular in FIG. 16, the cutting blade 87 is provided with a plurality of slots 87A which are inclined with respect to the cutting edge 87B of the blade 87. Into the slots 87A there insert pins 83C which are fixed to the portion 83B of the comb-like structure 83. At one of its ends, the blade 87 extends to form an appendage 87C in which a slot 87D orthogonal to the cutting edge 87B of the blade itself is made. In said slot 87D there engages a slider 91 provided with a movement, parallel to the cutting edge 87B, imparted by a cylinder-piston actuator or equivalent actuator 93. The actuator 93 is carried by the base plate 75, as may be seen in particular in FIG. 6. Thanks to the slot 87D, the cutting blade 87 can move in a direction orthogonal to the cutting edge 87B to follow the movement indicated by the double-headed arrow f83 of the comb-like structure 83, all the time maintaining mechanical connection with the actuator 93. Operation of the actuator 93 causes a thrust in the direction indicated by the arrow f87 (FIG. 16) on the blade 87, which consequently (thanks to the arrangement of the pins 83C and of the inclined slots 87A) will perform a movement with one component that is parallel and one component that is orthogonal to the longitudinal development of the comb-like structure 83. The function of this movement is, as will be clarified in what follows, that of cutting the loops of the row of stitches inside which the comb-like structure 83 is inserted for carrying out sewing of the toe of the tubular article.

[0071] In the sewing area 37 there is moreover provided a sewing machine, designated as a whole by 95, and illustrated in isolation from the other mechanical members in FIG. 7. The sewing machine 95 has been omitted for reasons of clarity of representation in FIGS. 1, 2 and 3. The sewing machine has a sewing needle 96 and a mouth for suction of the sewing thread 99. The reference number 101 designates the so-called "crochet", which imparts the raising and lowering movement on the sewing thread for the latter, fed by the thread bobbin, to be appropriately picked up by the sewing needle 96. The shape of the crochet 101 is provided purely by way of example. The crochet may, for instance, also be of the rotating or oscillating type. Likewise, the shape of the needle co-operating with it may be different. The structure of the sewing machine 95 is of a type in itself known to persons skilled in the art, and consequently will not be described in greater detail herein. The type of sewing performed by the needle 96 will in any case be described in greater detail with reference to the operation of the device.

[0072] The sewing machine 95 is provided with a sewing movement, indicated by the arrow f95 in FIG. 4, imparted by an actuator, designated as a whole by 97 again in FIG. 4.

[0073] Associated to the sewing machine 95 is a retention member for withholding the tubular article after sewing of the toe in order to carry out cutting of the part of fabric external to the seam. The retention member is designated as a whole by 103, and its position with respect to the other members of the device is illustrated in FIG. 4, whilst its structure is illustrated in detail in the perspective representation of FIG. 15.

[0074] The retention member 103 comprises a pair of bars 105, which are substantially parallel to the movement of the sewing machine 95 and to the fixed bar 77 and mobile bar 79. The retention bars 105 are provided with a movement orthogonal to their own development in the direction indicated by the double-headed arrow f105 in FIG. 15. In this way, they can be brought up to one another for withholding the article, or moved away from one another for releasing it. The movement is imparted by cylinder-piston actuators (not shown) housed in the structure of the retention member 103 fixed to the sewing machine 95. Since the retention member 103 is fixed to the sewing machine 95, it is also translated integrally with the sewing machine when the latter performs the sewing movement in the direction of the arrow f95. This enables the bars 105 to be brought into alignment with the tubular article that is being sewn.

[0075] Finally, fixed to the sewing machine 95 is a system for removal of the residue of yarn after the cutting operation has been performed by the blade 87, said system being designated as a whole by 107, and its position with respect to the other members of the device being shown in FIG. 4. The structure of the removal system 107 in a possible embodiment is illustrated in the perspective representation of FIG. 42. The removal system 107 is provided with one or more brush members 109 which rotate about the axis of a vertical shaft which is inserted into a suction mouth 111 through which the residue of yarn separated from the tubular article by the brush 109 is sucked in and removed.

[0076] Operation of the device so far described is illustrated in what follows with particular reference to FIGS. 17 to 43.

[0077] FIG. 17 shows the end step of knitting of a tubular article M by the needles 7 of the circular bed of needles of the circular knitting machine 3. The tubular article is knitted starting from an edge B1, which in FIG. 17 is in the bottom part and which in the finished article will remain open. When the tubular article M is a sock, said edge constitutes the elastic border of the sock. The final knitting step envisages formation of an edge B2 which is designed to be sewn to form the closed toe of the finished product.

[0078] During formation, the tubular article M comes to set itself in the space between the cylinder 5 of the needles 7 and the guide element 15, and more precisely the part of said guide element that projects with respect to the intake end 13A of the suction pipe 13. In this step, the intermediate separator 19 set along the suction pipe 13 is closed, and hence the jaws 21 and 22 grip the guide element 15, holding it in position inside the suction pipe 13. Preferably, at least one of the sets of sliders 31 and 32 is also gripped, with the sliders engaging the guide element. The portion of suction pipe between the intake end 13A and the intermediate separator 19 is kept at a negative pressure through a suction mouth 14 set adjacent to the intermediate separator 19, on the intake side of the suction pipe 13. The mouth 14 is connected to a suction fan or the like (not shown).

[0079] The stem 15C which can be extracted from the guide element 15 has been previously pushed into its extracted position by means of the air under pressure fed through the jaws of the separator member 19. In this extracted position, the head 15E of the stem 15C comes to be above the plane of the plates 59, which are opened to enable passage of the head itself. Closing of the shaped

plates 59 results in the stem 15C remaining engaged, through the hole 65 between the shaped plates 59, with the head 15E above the plates themselves. This means that the stem 15C will remain in the extracted position even in the absence of pressure inside the guide element 15, and hence even when the jaws of the separator member 19 open. In this configuration, the stems 63 fixed to the plates 59 are up against the axis of the stem 15C and are at least partially housed in a seat made in the stem below the head 15E of the latter, in such a way as to reduce the radial encumbrance of the stems 63 for the reasons that will be clarified in what follows.

[0080] When the tubular article M has been completed by the circular bed of needles 7 of the circular knitting machine 3, it is unloaded from the needles and, as a result of the negative pressure inside the suction pipe 13, is sucked in along the suction pipe 13 until it assumes the position shown in FIG. 18; i.e., until it comes up against the intermediate separator 19. Movement of the article M along the suction pipe 13 is guided by the guide element 15, the article M sliding in the free space between the inner wall of the suction pipe 13 and the guide element 15. In order to enable passage of the article M beyond the transverse surfaces on which the sliders 31 and 32 act, the latter are closed and opened in an alternating way, so that, during passage of the article M, only one of the sets of sliders, either 31 or 32, is engaged with the guide element 15. In this way, the tubular article M can pass beyond the sections in which the sliders are set and can reach the position illustrated in FIG. 18.

[0081] In order to cause the tubular article M to reach the output end 13B of the suction pipe 13, in such a way that it bears upon the wall formed by the shaped plates 59 in the position illustrated in FIG. 19, the intermediate separator 19 is opened by moving the jaws 21 and 22 away from one another. Suction through the mouth 14 can now be interrupted, whereas suction is activated through the suction line connected, by means of the connection 57, to the chamber 53 inside the mobile unit 39. This latter suction can be activated also in the previous step, i.e., the one represented in FIG. 18.

[0082] In this way, the tubular article M reaches the position represented in FIG. 19, in which it bears upon the wall formed by the shaped plates 59 in their closed configuration. Also in this case, movement of the tubular article M is guided by the guide element 15, which extends as far as the shaped plates 59. The sliders 33, which were previously closed for supporting the guide element 15 during opening of the jaws of the intermediate separator 19, are opened to enable passage of the article. Opening of the sliders 33 can be synchronized with a new movement of closure of the intermediate separator 19, in such a way that the guide element 15 will be all the time properly withheld in a substantially central position inside the suction pipe 13. Alternatively, lateral support of the guide element may be obtained, even at least in part, by means of engagement with the hole in the wall defined by the plates 59.

[0083] The function of the subsequent steps is to extract the tubular article M from the suction pipe 13 and turn it inside out to carry out the closing operation whereby the end edge B2 of the article is sewn to form the closed toe thereof.

[0084] For this purpose, as may be seen in FIG. 20 (which represents the end area alone of the suction pipe 13), the

plates 59 are displaced by means of the rotating spindles 61 so as to displace radially outwards the stems 63 fixed to the plates 59.

[0085] Since both the plates 59 and the stems 63 are above the output end 13B and hence outside the suction pipe 13, the movement of divarication of the stems 63 can be extended up to the point where the latter are brought into an external radial position (shown in FIG. 20) outside the encumbrance defined by the edge of the suction pipe 13. In this position, the portion of fabric of the article M close to the edge B1 is tensioned in such a way that it is substantially outside the encumbrance of the suction pipe 13.

[0086] Once the stems 63 have engaged the tubular article M, the telescopically extensible stem 15C of the guide element 15 can be retracted inside the portion 15B of the latter, thus reducing the pressure inside the part 15B of the guide element. Retraction of the stem is obtained by means of the effect of the extension spring 15D. In FIG. 20 the stem 15C is illustrated in its retracted position.

[0087] By means of a vertical movement downwards, as indicated by the arrow f39, of the unit 39, the stems 63 are brought into a position where they are set alongside one another externally and laterally with respect to the output end 13B of the suction pipe 13. The tubular article is still engaged by the stems 63 and has thus followed the latter, enveloping externally the suction pipe 13 in the area that surrounds the output end 13B of the latter. The lowering movement of the unit 39 proceeds until the stems 63 have been completely released from the tubular article M (FIG. 22).

[0088] In order to extract the tubular article M completely from inside the suction pipe 13 and turn it inside out by bringing it onto the outer surface of the suction pipe 13, the pushers 47 are pressed against the tubular article M (FIG. 23), and the unit 39 is at this point further displaced downwards, as indicated by the arrow f39 (FIG. 24). In this way, the further movement downwards, as indicated by the arrow f39, of the mobile unit 39 causes the tubular article M to be drawn along the outer surface of the suction pipe 13 until the unit 39 reaches the position illustrated in FIG. 24. In this position, the tubular article M is completely on the outside of the suction pipe 13. It is also turned inside out with respect to the configuration in which it was knitted by the circular knitting machine 3. The pushers 47 can be divaricated again to release the tubular article M, which remains in the position illustrated in FIG. 25 thanks to the elasticity of the article itself (and in particular of its initial edge Bi), which grips on the outer surface of the suction pipe 13. If the tubular article M is particularly long, the stroke downwards of the unit 39 with the pushers 47 in the closed position can be repeated a number of times, bringing the unit 39 each time back upwards after prior opening of the pushers 47 to prevent the latter from drawing the tubular article upwards again during the stroke upwards of the unit 39.

[0089] As may be seen in FIG. 24, the suction pipe 13 has two slits 13D which start from the output end 13B, i.e., from the edge of the suction pipe 13, and which extend in a direction parallel to the axis of the suction pipe for a certain stretch. The function of these slits is to enable the brackets 73 to grip the tubular article M and to slide it partially out of the suction pipe 13 for closing the toe of the article by sewing. Before this operation is carried out, however, the tubular article M may require angular positioning.

[0090] In fact, the sewing line which is designed to close the toe of the article must have a very precise orientation with respect to the article itself, which normally presents pockets, namely portions of fabric designed to form the heel area and the toe area of the foot of the sock or stocking. The sewing line must assume an extremely precise position with respect to these pockets of fabric. In order to orient the tubular article properly before the sewing operation, it is sufficient to provide, during knitting, marking of the article, for instance by means of a few stitches of yarn of a colour different from that of the yarn of the article. The marking thus obtained can be detected by means of a photo-electric cell (not shown) set in the proximity of the output end 13B of the suction pipe 13. Appropriate angular orientation of the tubular article M is at this point obtained by rotating, about its own axis, the portion 13C of the suction pipe 13 by means of the actuator 35. This rotation is the movement that brings the device from the position of FIG. 24 to the position of FIG. 25. The two figures differ, in fact, only as regards the different position of the slits 13D made in the proximity of the output end 13D of the suction pipe 13. The deviation in angular position between the two figures represents the amount by which the portion 13C of the suction pipe 13 is rotated with respect to the remaining part of the pipe itself in order to bring the tubular article into the correct angular position.

[0091] During this step of angular positioning, or in any case at an appropriate instant, the unit 39 is brought back upwards until it reaches the position illustrated in FIG. 26, the pushers 47 remaining in their retracted position, i.e., not in contact with the tubular article, during said movement upwards.

[0092] Once the unit 39 has reached the top position illustrated in FIG. 26, the pushers are closed again to press the tubular article M against the outer surface of the suction pipe 13 in the proximity of the output end 13B of the latter. Once the tubular article M has been engaged again by pressing it against the outer surface of the portion 13C of the suction pipe 13, the portion 13C can be rotated again so as to bring the slits 13D into their original position, namely on a plane which contains the axis of the portion 13C of the suction pipe and is orthogonal to the plane of FIG. 26. This movement of rotation of the portion 13C of the suction pipe 13, again obtained by means of the actuator 35, does not cause an angular movement of the tubular article M, in so far as the latter is withheld by the pushers 47, which are advantageously coated with a material having a high coefficient of friction. In this way, the portion 13C of the suction pipe 13 rotates inside the tubular article M in a sliding way, i.e., sliding on the inner surface of the latter.

[0093] In the configuration of FIG. 26, the tubular article M is in the correct angular position for the subsequent sewing operation, and can therefore be picked up by the brackets 73 of the gripping member 71. The brackets 73, which are brought up to one another, are for this purpose lowered until they move inside the suction pipe 13, into the position shown in FIG. 27, which represents a longitudinal cross section of the suction pipe 13 according to a plane orthogonal to the one represented in FIG. 26. The brackets 73 thus lie on a plane containing the axis A of the portion 13C of the suction pipe 13, on which also the slits 13D lie. In this way, divarication of the brackets 73, as indicated by the arrow f73 of FIG. 27, is enabled for tensioning the edge

B2 of the tubular article M and thus bringing the two flaps of the edge to come close to one another. The movement of divarication of the brackets 73 is combined with a movement of lifting-up of the brackets, which thus reach their final position, illustrated in FIG. 28. In the end phase of the raising movement of the brackets 73, the pushers 47 can be brought up to the suction pipe 13 again for withholding the tubular article M and thus causing longitudinal tensioning thereof.

[0094] In this position, the edge B2 of the tubular article M has been stretched or tensioned by means of the brackets 73 in such a way that the two flaps of the edge have been aligned to one another. The brackets 73 have been brought into a vertical position such that their bottom ends are slightly above the rectilinear bars 77 and 79. The latter can thus be brought up to one another to grip the tubular article M in an appropriate position of the edge B2. This is schematically represented in FIG. 29, which shows a longitudinal cross section according to a plane orthogonal to that of FIG. 28. The rectilinear bar 77 has been brought up to the fixed bar 79. In FIG. 28, L1 and L2 designate the two flaps of the edge B2 that have been brought close to one another as a result of the tensioning of the edge B2 performed by the brackets 73 of the gripping member 71. The article can be tensioned by means of a slight movement downwards of the unit 39 with the pushers 47.

[0095] FIG. 29A is a schematic enlargement of the area in which the flaps of fabric L1 and L2 forming the edge of the tubular article that is to be closed can be seen. As shown in the schematic section of the fabric, the latter presents a series of rows X2 set above the bars 77 and 79, some of these rows being made with a yarn thicker than that of the other rows. Said thicker rows form a portion of fabric of greater thickness, which is brought to bear upon the bars 77, 79 set alongside one another. The bars 77, 79 do not necessarily have to be pressed against the fabric, which, instead, is appropriately left free to slide so as to be tensioned transversely. Retention in the longitudinal direction is guaranteed by the fact that the portion of fabric of greater thickness obtained with the thicker yarn, designated by FG in FIG. 29A, bears upon the bars 77, 79. The portion of the tubular article made up of the rows X2 will be removed in the subsequent cutting operation, and is consequently normally produced with a yarn of poorer quality than the yarn of the remaining part of the tubular article M.

[0096] During the sewing operation, the edge formed by the rows X2 may be kept raised by means of suction through a suction mouth associated to the sewing machine 95 and designated, as a whole by 102 in FIGS. 33 and 34.

[0097] With a movement in the direction indicated by the arrow f83, the comb-like structure 83 is at this point pushed towards the tubular article M until the teeth 85 of the comb-like structure 83 penetrate inside the stitches or loops of the row that is set facing the comb-like structure 83, namely the row that is directly beneath the rectilinear bars 77 and 79. As may be seen in the diagram of FIG. 29A, the loops of this row (designated by X1) have a greater length than the remaining loops of the article in order to enable convenient insertion of the teeth 85 of the comb-like structure 83.

[0098] The movement in the direction indicated by the arrow f83 of the comb-like structure 83 is controlled by the

actuators **89** described previously (see **FIG. 6**) and not illustrated, for reasons of clarity, in **FIG. 29**. The closing movement of the rectilinear bars **77** and **79** and the subsequent movement of the comb-like structure **83** are represented in the sequence of **FIGS. 30** to **32**, which show the aforesaid movements in schematic plan views.

[0099] Once the teeth **85** of the comb-like structure **83** have penetrated the individual loops of the respective row in the tubular article **M**, the mobile rectilinear bar **77** can be retracted to enable insertion of the members of the sewing machine **95**, which performs sewing along the loops of the row of stitches underneath the row inside which the teeth **85** of the comb-like structure **83** have penetrated. The sewing operations are schematically illustrated in **FIG. 33**.

[0100] **FIG. 33** shows the needle **96** of the sewing machine **95**, the mouth **99**, and the crochet **101**. Also visible is the comb-like structure **83**, which is inserted inside the corresponding row of stitches or loops of the tubular product **M**. The sewing area is shown enlarged in **FIG. 34**. Clearly visible in the latter figure is how the comb-like structure **83** and the corresponding teeth **85** are made up of the two portions **83A** and **83B** (shown separate from one another in the perspective view of **FIG. 16**), which are connected together and between which the blade **87** is set, said blade, in this configuration, being in a retracted position, namely a position set back with respect to the teeth **85**.

[0101] Movement of the members of the sewing machine, and in particular of the needle **96** and the crochet **101** which feeds the sewing thread **F**, is shown in **FIG. 35**. In this example of embodiment, the needle **96** is a so-called piston needle, i.e., a needle provided with an opening and closing member **96A**. A needle of this kind is in itself known from the state of the art, in particular from the prior patents cited in the introductory part of the present description. It is, however, possible to use also other types of needles and/or crochets. For example latch needles or eye needles may be used. The sequence of the sewing operations may be clearly seen in **FIG. 35** and is in itself known for other types of applications, consequently, no detailed description is required herein.

[0102] It should however be noted that the pitch of the seam made by the sewing machine **95** with the needle **96** is smaller than the pitch of the comb-like structure **83** and of its teeth **85**, i.e., smaller than the pitch of the loops of the row **X1**. In particular, it is possible to envisage that the pitch of the seam will be equal to one half or to one third of the pitch of the loops of the row **X1**, and hence of the teeth **85** of the comb-like structure **83**.

[0103] **FIGS. 36, 37** and **38** show the subsequent step of cutting of the loops of the row **X2**, inside which the teeth **85** of the comb-like structure **83** have been inserted. Before carrying out this cutting operation, the flaps **L1** and **L2** of the tubular article **M**, which are by now joined together by the seam designated by **C** in **FIGS. 36** to **38**, are gripped and withheld by the retention bars **105** of the retention member **103** carried by the sewing machine **95** which has made the seam **C**. This makes it possible to withhold the tubular article **M** even after the cutting operation has been performed. Cutting is performed by moving the blade **87** housed inside the comb-like structure **83** so as to bring it from the position of **FIG. 36** to the position of **FIG. 37**. Thanks to this

movement, the blade **87** cuts all the loops of the row **X2** inside which the teeth **85** of the comb-like structure **83** were previously inserted.

[0104] At this point, the comb-like structure **83** can be moved away from the article to reach the position shown in **FIG. 38**, whilst the tubular article **M** is withheld by the retention bars **105** provided for this purpose and previously brought up to one another. The residue of cut yarn above the seam **C** is removed by the removal system **107**, which in **FIG. 39** is schematically represented by a brush with a horizontal axis, parallel to the bars **105**, but which may actually have the configuration shown in **FIG. 40**. The enlarged representation of **FIG. 41** shows the action mechanism of the brush **109**, in this case with a vertical axis, for removal of the residue of yarn, designated by **FR** in the enlarged representation of **FIG. 41**.

[0105] Once said sewing, cutting and yarn-residue-removal operations have been completed, the article **M** can be removed from the device, after the article has been turned inside out again to assume its final configuration corresponding to the one in which it was produced by the circular knitting machine **3**. For this purpose, reverse operations are performed with respect to the ones previously carried out for turning the article inside out by means of the movement of the unit **39** and the action of the sliders **47**. Negative pressure is at this point applied inside the suction pipe **13** through a suction mouth **16** (**FIG. 43**) in such a way that the article, with its toe closed by the seam **C**, is sucked through the mouth **16** and is removed from the device.

[0106] Removal is facilitated by the movement of the part **15B** of the guide element **15** with respect to the part **15A**, about the hinge axis **17**, so that the part **15B** of the guide element comes up against the inner wall of the suction pipe **13** on the opposite side with respect to the one where the suction mouth **16** is set, leaving a wider passage for transit of the sewn tubular article **M** towards the suction mouth **16**.

[0107] Once the above operations have been completed, the device returns to the configuration represented in **FIG. 17** for sewing of a subsequent tubular article **M**, which, in the meantime, has started its formation on the circular knitting machine **3**.

[0108] It is understood that the drawings only illustrate a possible embodiment of the invention given purely to provide a practical demonstration of said invention, which may vary in its embodiments and arrangements without thereby departing from the scope of the underlying idea. The possible presence of reference numbers in the attached claims has the sole purpose of facilitating reading thereof in the light of the foregoing description and of the annexed drawings, and in no way limits the scope of protection defined in the claims.

1. A device for picking up a tubular knitted article from a cylinder of a circular knitting machine and for closing the toe of said article, said device comprising means for closing said toe of the tubular article and being characterized in that it comprises:

a suction pipe that develops from an intake end, in an area where the tubular article is picked up from the circular knitting machine, to an output end, in an area where the toe of the article is sewn; and

- a guide element for guiding the tubular article, which develops inside said suction pipe and extends outside the latter from the intake-end side to be inserted inside the cylinder of said circular knitting machine, there being provided, between the guide element and the inner wall of the suction pipe, a space for transit of the tubular article.
- 2.** The device according to claim 1, in which to the output end of the suction pipe there is associated a system for extraction of the tubular article from the suction pipe and for turning said tubular article inside out onto the outside of the suction pipe.
- 3.** The device according to claim 1, or claim 2, in which said suction pipe is internally divided into two consecutive portions by an openable intermediate separator.
- 4.** The device according to claim 1, or **2**, or **3**, in which associated to said suction pipe are means for supporting the guide element inside the suction pipe, said supporting element enabling transit of the tubular article in the space between the inner wall of the suction pipe and the guide element inside it.
- 5.** The device according to claim 4, in which said supporting means comprise transverse sliders which are carried by the suction pipe and are mobile for engaging the guide element inside said suction pipe and for alternately being released from the latter.
- 6.** The device according to claim 4 or **5**, in which said supporting means are set in three sections set at a distance apart along the suction pipe.
- 7.** The device according to claims **3** and **6**, in which two of said sections are set in the portion of the suction pipe between the intake end and the intermediate separator, and one of said sections is set between the output end and the intermediate separator.
- 8.** The device according to one or more of the foregoing claims, in which said guide element has a portion which is extensible towards the output end of the suction pipe.
- 9.** The device according to claim 8, in which said extensible portion is provided with single-acting pneumatically controlled telescopic elongation means.
- 10.** The device according to claims **3** and **9**, in which said intermediate separator is associated to an air-feed channel for controlling telescopic elongation of said guide element.
- 11.** The device according to one or more of the foregoing claims, in which said guide element is made up of two parts which are hinged together about an axis orthogonal to the axis of the suction pipe.
- 12.** The device according to at least claim 2, in which said system for extraction of the tubular article from the suction pipe comprises:
- widening members for widening the tubular article at the initial edge of the article itself, said members causing widening of the initial edge of the tubular article beyond the outer diameter of the suction pipe; and
- members for turning the tubular article inside out from inside the suction pipe onto the outside of the latter.
- 13.** The device according to at least claim 12, in which said widening members comprise a plurality of stems which are approximately parallel to the axis of the suction pipe and are provided with a motion of approach to and recession from the axis of the suction pipe so as to assume a position close to the axis of the suction pipe and a position external to the diameter of the suction pipe, said stems being axially mobile along the outside of the suction pipe.
- 14.** The device according to claim 13, in which said stems are each carried by a plate roughly orthogonal to the axis of the suction pipe; when the stems are in the position close to the axis of the suction pipe, the plates forming a contrast wall for arrest of the tubular article that is being conveyed inside said suction pipe.
- 15.** The device according to claim 14, in which each of said plates is carried by a rotating spindle roughly parallel to the axis of the suction pipe and to said stems, the rotation of said spindle causing the approach and recession movement of the stems with respect to the axis of said suction pipe.
- 16.** The device according to claim 14 or claim 15, in which the contrast wall formed by said plates when the stems are in a position close to the axis of the suction pipe has a central hole aligned to the guide element, said guide element inserting, with its own end, inside said hole.
- 17.** The device according to one or more of claims 12 to 16, in which said guide element has a lateral seat for insertion of said stems.
- 18.** The device according to one or more of claims 12 to 17, in which said members for turning the tubular article inside out comprise radial pushers that move radially and axially with respect to said suction pipe and outside the latter so as to press against the outer surface of the suction pipe and draw along said outer surface the tubular article.
- 19.** The device according to one or more of claims 12 to 18, in which associated to said widening members is a suction line for sucking the tubular article up against said widening members.
- 20.** The device according to one or more of claims 12 to 19, in which said widening members and said members for turning the tubular article inside out are carried by a unit which is axially mobile along the suction pipe.
- 21.** The device according to claims **19** and **20**, in which said suction line is connected to a suction chamber formed in said unit.
- 22.** The device according to one or more of the foregoing claims, in which said suction pipe comprises an end part which is angularly mobile about its own axis with respect to the remaining part of the suction pipe, an actuator being provided for controlling the movement of rotation of said end part about its own axis.
- 23.** The device according to one or more of the foregoing claims, in which at its own output end the suction pipe has slits for passage of a member for gripping the end edge of the article.
- 24.** The device according to claim 23, in which said gripping member has two brackets which can be brought up to and moved away from one another so as to engage the tubular article at the end edge of the latter in two roughly diametrically opposite points and to tension said end edge, said brackets being axially mobile with respect to said suction pipe.
- 25.** The device according to one or more of the foregoing claims, comprising a member for retention of the tubular article after sewing of the toe, in order to carry out cutting of the part of fabric external to the seam thus formed.
- 26.** The device according to at least claim 3, in which associated to said suction pipe is a first suction opening, set

between the intermediate separator and the intake end of said suction pipe, and a second suction opening, set between the output end and the intermediate separator, through said second suction opening the article being removed after sewing of the toe thereof.

27. The device according to at least claim 3, in which said intermediate separator is made up of a pair of jaws which engage said guide element inside the suction pipe.

28. The device according to at least claim 8, in which said extensible portion is engaged, at its own free end, to a system for closing the output end of the suction pipe.

29. The device according to claims **14** and **28**, in which said closing system consists of said plates that carry said stems, said plates in their closed configuration defining a hole for engagement of the free end of said extensible portion.

* * * * *