



INTERNATIONAL APPLICATION PUBLISHED UNDER THE PATENT COOPERATION TREATY (PCT)

<p>(51) International Patent Classification ⁶ : C12N 15/52, 9/00, A61K 31/70, C12N 5/10</p>	A1	<p>(11) International Publication Number: WO 96/09392</p> <p>(43) International Publication Date: 28 March 1996 (28.03.96)</p>
<p>(21) International Application Number: PCT/US95/11995</p> <p>(22) International Filing Date: 21 September 1995 (21.09.95)</p> <p>(30) Priority Data: 08/311,760 23 September 1994 (23.09.94) US</p> <p>(71) Applicant: RIBOZYME PHARMACEUTICALS, INC. [US/US]; 2950 Wilderness Place, Boulder, CO 80301 (US).</p> <p>(72) Inventors: STINCHCOMB, Dan, T.; 7203 Old Post Road, Boulder, CO 80301 (US). McSWIGGEN, James; 4866 Franklin Drive, Boulder, CO 80301 (US). NEWTON, Roger, S.; 1425 Bardstown Trail, Ann Arbor, MI 48105 (US). RAMHARACK, Randy; 2465 Antietam Drive, Ann Arbor, MI 48105 (US).</p> <p>(74) Agents: WARBURG, Richard, J. et al.; Lyon & Lyon, Suite 4700, 633 West Fifth Street, Los Angeles, CA 90071-2066 (US).</p>		<p>(81) Designated States: AU, CA, JP, KR, MX, European patent (AT, BE, CH, DE, DK, ES, FR, GB, GR, IE, IT, LU, MC, NL, PT, SE).</p> <p>Published <i>With international search report. Before the expiration of the time limit for amending the claims and to be republished in the event of the receipt of amendments.</i></p>
<p>(54) Title: RIBOZYME TREATMENT OF DISEASES OR CONDITIONS RELATED TO LEVELS OF PLASMA LIPOPROTEIN (a) [Lp(a)] BY INHIBITING APOLIPOPROTEIN (a) [APO(a)]</p>		
<p>(57) Abstract</p> <p>Enzymatic RNA molecules which cleave apo(a) mRNA. Use of these catalytic RNA molecules for the treatment of conditions related to lipoprotein A levels, such as atherosclerosis, myocardial infarction, strokes; testenosis and heart diseases.</p>		

FOR THE PURPOSES OF INFORMATION ONLY

Codes used to identify States party to the PCT on the front pages of pamphlets publishing international applications under the PCT.

AT	Austria	GB	United Kingdom	MR	Mauritania
AU	Australia	GE	Georgia	MW	Malawi
BB	Barbados	GN	Guinea	NE	Niger
BE	Belgium	GR	Greece	NL	Netherlands
BF	Burkina Faso	HU	Hungary	NO	Norway
BG	Bulgaria	IE	Ireland	NZ	New Zealand
BJ	Benin	IT	Italy	PL	Poland
BR	Brazil	JP	Japan	PT	Portugal
BY	Belarus	KE	Kenya	RO	Romania
CA	Canada	KG	Kyrgystan	RU	Russian Federation
CF	Central African Republic	KP	Democratic People's Republic of Korea	SD	Sudan
CG	Congo			SE	Sweden
CH	Switzerland	KR	Republic of Korea	SI	Slovenia
CI	Côte d'Ivoire	KZ	Kazakhstan	SK	Slovakia
CM	Cameroon	LI	Liechtenstein	SN	Senegal
CN	China	LK	Sri Lanka	TD	Chad
CS	Czechoslovakia	LU	Luxembourg	TG	Togo
CZ	Czech Republic	LV	Larvia	TJ	Tajikistan
DE	Germany	MC	Monaco	TT	Trinidad and Tobago
DK	Denmark	MD	Republic of Moldova	UA	Ukraine
ES	Spain	MG	Madagascar	US	United States of America
FI	Finland	ML	Mali	UZ	Uzbekistan
FR	France	MN	Mongolia	VN	Viet Nam
GA	Gabon				

DESCRIPTIONRIBOZYME TREATMENT OF DISEASES OR CONDITIONS
RELATED TO LEVELS OF PLASMA LIPOPROTEIN (a) [Lp(a)] BY
INHIBITING APOLIPOPROTEIN (a) [APO(a)]

5

Field of the Invention

The present invention relates to therapeutic compositions and methods for the treatment or diagnosis of diseases or conditions related to Lp(a) levels, such as atherosclerosis, myocardial infarction, stroke, and restenosis.

10

Background Of The Invention

The following is a brief description of the physiological role of Lp(a). The discussion is not meant to be complete and is provided only for understanding of the invention that follows. This summary is not an admission that any of the work described below is prior art to the claimed invention.

15

Low density lipoproteins (LDLs) are mainly composed of cholesterol, phospholipids and a single hydrophobic protein, apolipoprotein B [apoB]. They are considered as the major carriers of cholesterol in human plasma (for review see Uterman, G. (1989) Science 246, 904-910). ApoB, the only protein subunit of LDL, recognizes and binds to LDL receptors on the surface of cells. This LDL-LDL receptor interaction results in the internalization of the LDL and the eventual release of cholesterol inside the cell.

20

A modified form of LDL, termed as lipoprotein (a) [Lp(a)], was discovered in 1963 [Berg, K. (1963) Acta Pathol. Microbiol. Scand. 59, 369]. Covalent linkage of an additional glycoprotein, apo(a), to the LDL distinguishes Lp(a) from LDL. Several studies have recently suggested that elevated levels of Lp(a) in human plasma is linked to heart disease (Gurakar, et al., (1985) Atherosclerosis 57, 293-301; Leren, et al., (1988) Atherosclerosis 73, 135-141; Utermann, Supra). The Lp(a) levels range over 1000 fold and individuals with top quartile of plasma Lp(a) levels have two-to five-fold increased probability of developing atherosclerosis.

30

Atherosclerosis is a disease associated with hardening and loss of elasticity of arterial walls. High concentrations of cholesterol, in the form of Lp(a), in human blood plasma is one of the most important factors responsible for atherosclerosis. Deposition of cholesterol in the
5 Macrophages and smooth muscle cells associated with arterial walls cause plaques (atheromatous lesions) which cause proliferation of adjoining smooth muscle cells. With time, these plaques grow in size causing hardening of the arterial walls and loss of elasticity, which in turn results in rupturing of the arterial walls, blood clotting and blockage of blood flow in
10 the artery (for details see Textbook of medical physiology Guyton, A.C., (Saunders Company, Philadelphia, 1991) pp. 761-764).

Lp(a) and/or apo(a) levels correlate well with an increased risk of atherosclerosis and its subsequent manifestations such as myocardial infarction, stroke, and restenosis. The apo(a) protein is unique to humans,
15 Old World primates and hedgehogs; its absence in common laboratory animals has made exploration of the physiological role of apo(a) levels difficult. Recently, a transgenic mouse expressing the human gene encoding apo(a) was constructed [Lawn et al., (1992) Nature 360, 670-672]. The transgenic mice are more susceptible than control litter-mates to
20 the development of lipid-rich regions in the aorta. Moreover, human apo(a) expression colocalizes to the regions of fat deposition. Thus, overexpression of apo(a) directly leads to atherosclerotic-like lesions in experimental animals. This observation lends credence to the hypothesis that elevated levels of apo(a) in humans contribute to atherosclerotic
25 disease.

Apolipoprotein(a) is a large glycoprotein which varies in size from 300-800 KDa. Thirty four different isoforms have been characterized from human plasma. The only human cDNA clone currently available encompass 14 kilobase message that encodes apo(a) [McLean et al.,
30 (1987) Nature 330, 132-137]. A Rhesus monkey cDNA representing a part of the 3' end of the apo(a) mRNA has also been cloned and sequenced (Tomlinson et al., 1989 J. Biol. Chem. 264, 5957-5965). Sequence analysis of the cloned cDNA revealed two unique facets of the apo(a) structure. First, the apo(a) cDNA is remarkably repetitious. The
35 reconstructed apo(a) cDNA encodes a protein of 4,529 amino acids; 4,210 of the residues are present in 37 repeats of 114 amino acids each. The

repeated units themselves are especially homologous; 24 are identical in nucleotide sequence, four more share a sequence that differs in only three nucleotides and the remaining repeats differ by only 11 to 71 bases.

5 Secondly, apolipoprotein(a) is highly homologous to the serine protease, plasminogen. Plasminogen consists of five repeated homologous domains termed kringles (which are approximately 50% homologous in their amino sequences) followed by a trypsin-like protease domain. Kringle IV of plasminogen is very homologous to the 37 repeats of apo(a) [75-85% at the protein level]. In addition, the 5' untranslated region, the signal peptide region, kringle V, the protease domain, and the 10 3' untranslated region of plasminogen are 98%, 100%, 91%, 94% and 87% homologous to apo(a) sequences, respectively. Relative to plasminogen, apo(a) is missing kringles I, II, and III and, as mentioned above, has extensively duplicated kringle IV. Despite the high degree of 15 homology apo(a) cannot be converted into a protease by tissue type plasminogen activator (tPA). This is because of a single amino acid substitution in apo(a) at the site of activation of plasminogen by tPA (Utermann, *supra*). *In vitro* studies have indicated that apo(a) and Lp(a) compete with plasminogen for binding to the plasminogen receptor and 20 fibrin which supports the correlation between high Lp(a) levels and myocardial infraction (Gonzalez-Gronow et al., (1989) Biochemistry 28, 2374-2378; Hajjar et al., (1989) Nature 339, 303-305; Miles et al., (1989) Nature 339, 301-303). Recent *in vivo* studies in human (Moliterno et al., 1993 Circulation 88, 935-940) and monkey (Williams et al., 1993 25 Atheroscler. Thromb. 13, 548-554) support a role for Lp(a) in preventing clot lysis.

The extraordinary homology between apo(a) and plasminogen presents several barriers to drug development. Small molecule inhibitors of apo(a) would have to selectively bind apo(a) without negatively 30 impacting plasminogen function. Similarly, antisense approaches will be limited by the overall nucleotide sequence homology between the two genes. Current dietary and drug therapies (Gurakar, *et al.*, *supra*; Leren *et al.*, *supra*), with the exception of nicotinic acid, have little or no effect on apo(a) levels.

35 Applicant now shows that these same limitations are opportunities for ribozyme therapy. The cleavage site specificity of ribozymes allows one to

identify ribozyme target sites present in apo(a) mRNA but completely absent in the mRNA of plasminogen. For instance, there are 13 hammerhead cleavage sites present in the highly conserved kringles of apo(a) that are not present in kringle IV of plasminogen. Likewise, the last
5 kringle repeat, protease domain and 3' untranslated region of apo(a) contain 21 hammerhead ribozyme cleavage sites present in apo(a) that are not present in plasminogen. Thus, ribozymes that target apo(a) mRNA represent unique therapeutics and diagnostic tools for the treatment and diagnosis of those at high risk of atherosclerosis.

10

Summary of the Invention

This invention relates to ribozymes, or enzymatic RNA molecules, directed to cleave mRNA species encoding apo(a). In particular, applicant describes the selection and function of ribozymes capable of cleaving this RNA and their use to reduce levels of apo(a) in various tissues to treat the
15 diseases discussed herein. Such ribozymes are also useful for diagnostic uses.

Ribozymes that cleave apo(a) mRNA represent a novel therapeutic approach to atherosclerosis. Ribozymes may show greater perdurance or lower effective doses than antisense molecules due to their catalytic
20 properties and their inherent secondary and tertiary structures. Such ribozymes, with their catalytic activity and increased site specificity (as described below), represent more potent and safe therapeutic molecules than antisense oligonucleotides.

Applicant indicates that these ribozymes are able to inhibit expression
25 of apo(a) and that the catalytic activity of the ribozymes is required for their inhibitory effect. Those of ordinary skill in the art, will find that it is clear from the examples described that other ribozymes that cleave target apo(a) encoding mRNAs may be readily designed and are within the invention.

Six basic varieties of naturally-occurring enzymatic RNAs are known
30 presently. Each can catalyze the hydrolysis of RNA phosphodiester bonds in *trans* (and thus can cleave other RNA molecules) under physiological conditions. Table I summarizes some of the characteristics of these ribozymes. In general, enzymatic nucleic acids act by first binding to a target RNA. Such binding occurs through the target binding portion of a

enzymatic nucleic acid which is held in close proximity to an enzymatic portion of the molecule that acts to cleave the target RNA. Thus, the enzymatic nucleic acid first recognizes and then binds a target RNA through complementary base-pairing, and once bound to the correct site, acts enzymatically to cut the target RNA. Strategic cleavage of such a target RNA will destroy its ability to direct synthesis of an encoded protein. After an enzymatic nucleic acid has bound and cleaved its RNA target, it is released from that RNA to search for another target and can repeatedly bind and cleave new targets.

The enzymatic nature of a ribozyme is advantageous over other technologies, such as antisense technology (where a nucleic acid molecule simply binds to a nucleic acid target to block its processing and translation) since the concentration of ribozyme necessary to affect a therapeutic treatment is lower than that of an antisense oligonucleotide. This advantage reflects the ability of the ribozyme to act enzymatically. Thus, a single ribozyme molecule is able to cleave many molecules of target RNA. In addition, the ribozyme is a highly specific inhibitor, with the specificity of inhibition depending not only on the base pairing mechanism of binding to the target RNA, but also on the mechanism of target RNA cleavage. Single mismatches, or base-substitutions, near the site of cleavage can completely eliminate catalytic activity of a ribozyme. Similar mismatches in antisense molecules do not prevent their action (Woolf, T. M., et al., 1992, *Proc. Natl. Acad. Sci. USA*, 89, 7305-7309). Thus, the specificity of action of a ribozyme is greater than that of an antisense oligonucleotide binding the same RNA site.

In preferred embodiments of this invention, the enzymatic nucleic acid molecule is formed in a hammerhead or hairpin motif, but may also be formed in the motif of a hepatitis delta virus, group I intron or RNaseP RNA (in association with an RNA guide sequence) or *Neurospora* VS RNA. Examples of such hammerhead motifs are described by Rossi *et al.*, 1992, *Aids Research and Human Retroviruses*, 8, 183, of hairpin motifs by Hampel *et al.*, "RNA Catalyst for Cleaving Specific RNA Sequences," filed September 20, 1989, which is a continuation-in-part of U.S. Serial No. 07/247,100 filed September 20, 1988, Hampel and Tritz, 1989, *Biochemistry*, 28, 4929, and Hampel *et al.*, 1990, *Nucleic Acids Res.* 18,299, and an example of the hepatitis delta virus motif is described by

Perrotta and Been, 1992, Biochemistry, 31, 16, of the RNaseP motif by Guerrier-Takada et al., 1983, Cell, 35, 849, *Neurospora* VS RNA ribozyme motif is described by Collins (Saville and Collins, 1990 Cell 61, 685-696; Saville and Collins, 1991 Proc. Natl. Acad. Sci. USA 88, 8826-8830; 5 Collins and Olive, 1993 Biochemistry 32, 2795-2799) and of the Group I intron by Cech et al., U.S. Patent 4,987,071. These specific motifs are not limiting in the invention and those skilled in the art will recognize that all that is important in an enzymatic nucleic acid molecule of this invention is that it has a specific substrate binding site which is complementary to one 10 or more of the target gene RNA regions, and that it have nucleotide sequences within or surrounding that substrate binding site which impart an RNA cleaving activity to the molecule.

The invention provides a method for producing a class of enzymatic cleaving agents which exhibit a high degree of specificity for the RNA of a 15 desired target. The enzymatic nucleic acid molecule is preferably targeted to a highly conserved sequence region of a target apo(a) encoding mRNA such that specific treatment of a disease or condition can be provided with either one or several enzymatic nucleic acids. Such enzymatic nucleic acid molecules can be delivered exogenously to specific cells as required. 20 Alternatively, the ribozymes can be expressed from DNA vectors that are delivered to specific cells.

Synthesis of nucleic acids greater than 100 nucleotides in length is difficult using automated methods, and the therapeutic cost of such molecules is prohibitive. In this invention, small enzymatic nucleic acid 25 motifs (*e.g.*, of the hammerhead or the hairpin structure) are used for exogenous delivery. The simple structure of these molecules increases the ability of the enzymatic nucleic acid to invade targeted regions of the mRNA structure. However, these catalytic RNA molecules can also be expressed within cells from eukaryotic promoters (*e.g.*, Scanlon, K. J., et al., 1991, 30 Proc. Natl. Acad. Sci. USA, 88, 10591-5; Kashani-Sabet, M., et al., 1992, Antisense Res. Dev., 2, 3-15; Dropulic, B., et al., 1992, J Virol, 66, 1432-41; Weerasinghe, M., et al., 1991, J Virol, 65, 5531-4; Ojwang, J. O., et al., 1992, Proc. Natl. Acad. Sci. USA, 89, 10802-6; Chen, C. J., et al., 1992, Nucleic Acids Res., 20, 4581-9; Sarver, H., et al., 1990, Science, 247, 35 1222-1225)). Those skilled in the art realize that any ribozyme can be expressed in eukaryotic cells from the appropriate DNA vector. The activity

of such ribozymes can be augmented by their release from the primary transcript by a second ribozyme (Draper et al., PCT WO93/23569, and Sullivan et al., PCT WO94/02595, both hereby incorporated in their totality by reference herein; Ohkawa, J., et al., 1992, *Nucleic Acids Symp. Ser.*, 27, 15-6; Taira, K., et al., 1991, *Nucleic Acids Res.*, 19, 5125-30; Ventura, M., et al., 1993, *Nucleic Acids Res.*, 21, 3249-55) .

Thus, in a first aspect, the invention features ribozymes that inhibit apo(a) production. These chemically or enzymatically synthesized RNA molecules contain substrate binding domains that bind to accessible regions of their target mRNAs. The RNA molecules also contain domains that catalyze the cleavage of RNA. The RNA molecules are preferably ribozymes of the hammerhead or hairpin motif. Upon binding, the ribozymes cleave the target apo(a) encoding mRNAs, preventing translation and protein accumulation. In the absence of the expression of the target gene, a therapeutic effect may be observed.

By "inhibit" is meant that the activity or level of apo(a) encoding mRNA is reduced below that observed in the absence of the ribozyme, and preferably is below that level observed in the presence of an inactive RNA molecule able to bind to the same site on the mRNA, but unable to cleave that RNA.

Such ribozymes are useful for the prevention of the diseases and conditions discussed above, and any other diseases or conditions that are related to the level of apo(a) activity in a cell or tissue. By "related" is meant that the inhibition of apo(a) mRNA translation, and thus reduction in the level of apo(a), will relieve to some extent the symptoms of the disease or condition.

Ribozymes are added directly, or can be complexed with cationic lipids, packaged within liposomes, or otherwise delivered to target cells. The RNA or RNA complexes can be locally administered to relevant tissues through the use of a catheter, infusion pump or stent, with or without their incorporation in biopolymers. In preferred embodiments, the ribozymes have binding arms which are complementary to the sequences in Tables II, IV, VI and VII. Examples of such ribozymes are shown in Tables III, V, VI and VII. Examples of such ribozymes consist essentially of sequences defined in these Tables. By "consists essentially of" is meant that the active

ribozyme contains an enzymatic center equivalent to those in the examples, and binding arms able to bind mRNA such that cleavage at the target site occurs. Other sequences may be present which do not interfere with such cleavage.

5 In another aspect of the invention, ribozymes that cleave target molecules and inhibit apo(a) activity are expressed from transcription units inserted into DNA, RNA, or viral vectors. Preferably, the recombinant vectors capable of expressing the ribozymes are locally delivered as described above, and transiently persist in target cells. Once expressed,
10 the ribozymes cleave the target mRNA. The recombinant vectors are preferably DNA plasmids or adenovirus vectors. However, other mammalian cell vectors that direct the expression of RNA may be used for this purpose.

Other features and advantages of the invention will be apparent from
15 the following description of the preferred embodiments thereof, and from the claims.

Description Of The Preferred Embodiments

The drawings will first briefly be described.

Drawings:

20 Figure 1 is a diagrammatic representation of the hammerhead ribozyme domain known in the art. Stem II can be ≥ 2 base-pair long or may be a loop region without base pairing.

Figure 2a is a diagrammatic representation of the hammerhead ribozyme domain known in the art; Figure 2b is a diagrammatic
25 representation of the hammerhead ribozyme as divided by Uhlenbeck (1987, *Nature*, 327, 596-600) into a substrate and enzyme portion; Figure 2c is a similar diagram showing the hammerhead divided by Haseloff and Gerlach (1988, *Nature*, 334, 585-591) into two portions; and Figure 2d is a similar diagram showing the hammerhead divided by Jeffries and Symons
30 (1989, *Nucl. Acids. Res.*, 17, 1371-1371) into two portions.

Figure 3 is a representation of the general structure of the hairpin ribozyme domain known in the art. H, is A, U or C. Y is U or C. N is A, U, G,

or C. N' is the complementary sequence of N. Helix 4 can be ≥ 2 base-pair long

Figure 4 is a representation of the general structure of the hepatitis delta virus ribozyme domain known in the art.

5 Figure 5 is a representation of the general structure of the *Neurospora* VS RNA enzyme motif.

Figure 6 is a schematic representation of an RNase H accessibility assay. Specifically, the left side of Figure 6 is a diagram of complementary DNA oligonucleotides bound to accessible sites on the target RNA. Complementary DNA oligonucleotides are represented by broad lines labeled A, B, and C. Target RNA is represented by the thin, twisted line. The right side of Figure 5 is a schematic of a gel separation of uncut target RNA from a cleaved target RNA. Detection of target RNA is by autoradiography of body-labeled, T7 transcript. The bands common to each lane represent uncleaved target RNA; the bands unique to each lane represent the cleaved products.

10
15

Ribozymes

Ribozymes of this invention block to some extent apo(a) expression and can be used to treat disease or diagnose such disease. Ribozymes will be delivered to cells in culture and to tissues in animal models of Lp(a). Ribozyme cleavage of apo(a) mRNA in these systems may prevent or alleviate disease symptoms or conditions.

20

Target sites

Targets for useful ribozymes can be determined as disclosed in Draper et al supra, Sullivan *et al.*, supra, as well as by Draper et al., "Method and reagent for treatment of arthritic conditions U.S.S.N. 08/152,487, filed 11/12/93, and hereby incorporated by reference herein in totality. Rather than repeat the guidance provided in those documents here, below are provided specific examples of such methods, not limiting to those in the art. Ribozymes to such targets are designed as described in those applications and synthesized to be tested *in vitro* and *in vivo*, as also described. Such ribozymes can also be optimized and delivered as described therein. While specific examples to monkey and human RNA

25
30

are provided, those in the art will recognize that the equivalent human RNA targets described can be used as described below. Thus, the same target may be used, but binding arms suitable for targetting human RNA sequences are present in the ribozyme. Such targets may also be selected
5 as described below.

The sequence of human and monkey apo(a) mRNA can be screened for accessible sites using a computer folding algorithm. Regions of the mRNA that did not form secondary folding structures and that contain potential hammerhead or hairpin ribozyme cleavage sites can be
10 identified. These sites are shown in Tables II, IV, and VI - VII. (All sequences are 5' to 3' in the tables.) While monkey and human sequences can be screened and ribozymes thereafter designed, the human targetted sequences are of most utility. However, as discussed in Stinchcomb *et al.* "Method and Composition for Treatment of Restenosis and Cancer Using
15 Ribozymes," U.S.S.N. 08/245,466, filed 5/18/94, and hereby incorporated by reference herein, monkey targeted ribozymes are useful to test efficacy of action of the ribozyme prior to testing in humans. The nucleotide base position is noted in the Tables as that site to be cleaved by the designated type of ribozyme.

20 Ribozyme target sites were chosen such that the cleavage sites are present in apo(a) mRNA but completely absent in the mRNA of plasminogen (Tables II, IV, VI and VII). This is because there exists extraordinary homology between apo(a) and plasminogen (see above).

It must be established that the sites predicted by the computer-based
25 RNA folding algorithm correspond to potential cleavage sites. Hammerhead and hairpin ribozymes are designed that could bind and are individually analyzed by computer folding (Jaeger *et al.*, 1989 Proc. Natl. Acad. Sci. USA, 86, 7706-7710) to assess whether the ribozyme sequences fold into the appropriate secondary structure. Those ribozymes
30 with unfavorable intramolecular interactions between the binding arms and the catalytic core are eliminated from consideration. Varying binding arm lengths can be chosen to optimize activity. Generally, at least 5 bases on each arm are able to bind to, or otherwise interact with, the target RNA.

Referring to Figure 6, mRNA is screened for accessible cleavage sites
35 by the method described generally in McSwiggen, *US Patent Application*

07/883,849 filed 5/1/92, entitled "Assay for ribozyme target site," hereby incorporated by reference herein. Briefly, DNA oligonucleotides representing potential hammerhead or hairpin ribozyme cleavage sites are synthesized. A polymerase chain reaction is used to generate a substrate
5 for T7 RNA polymerase transcription from human or monkey apo(a) cDNA clones. Labeled RNA transcripts are synthesized *in vitro* from the two templates. The oligonucleotides and the labeled transcripts are annealed, RNaseH is added and the mixtures are incubated for the designated times at 37°C. Reactions are stopped and RNA separated on sequencing
10 polyacrylamide gels. The percentage of the substrate cleaved is determined by autoradiographic quantitation using a phosphor imaging system. From these data, hammerhead or hairpin ribozyme sites are chosen as the most accessible.

Ribozymes of the hammerhead or hairpin motif are designed to
15 anneal to various sites in the mRNA message. The binding arms are complementary to the target site sequences described above. The ribozymes are chemically synthesized. The method of synthesis used follows the procedure for normal RNA synthesis as described in Usman et al., 1987 J. Am. Chem. Soc., 109, 7845-7854 and in Scaringe et al., 1990
20 Nucleic Acids Res., 18, 5433-5441 and makes use of common nucleic acid protecting and coupling groups, such as dimethoxytrityl at the 5'-end, and phosphoramidites at the 3'-end. The average stepwise coupling yields were >98%. Inactive ribozymes are synthesized by substituting a U for G₅ and a U for A₁₄ (numbering from Hertel et al., 1992 Nucleic Acids Res.,
25 20, 3252). Hairpin ribozymes are synthesized in two parts and annealed to reconstruct the active ribozyme (Chowrira and Burke, 1992 Nucleic Acids Res., 20, 2835-2840). All ribozymes are modified to enhance stability by modification of five ribonucleotides at both the 5' and 3' ends with 2'-O-methyl groups. Ribozymes are purified by gel electrophoresis using
30 general methods or are purified by high pressure liquid chromatography (HPLC; See Usman *et al.*, Synthesis, deprotection, analysis and purification of RNA and ribozymes, filed May, 18, 1994, U.S.S.N. 08/245,736, the totality of which is hereby incorporated herein by reference.) and were resuspended in water.

35 The sequences of the chemically synthesized ribozymes useful in this study are shown in Tables III, V, VI, and VII. Those in the art will recognize

that these sequences are representative only of many more such sequences where the enzymatic portion of the ribozyme (all but the binding arms) is altered to affect activity. For example, stem loop II sequence of hammerhead ribozymes listed in Tables III and V (5'-GGCCGAAAGGCC-
5 3') can be altered (substitution, deletion and/or insertion) to contain any sequence provided a minimum of two base-paired stem structure can form. Similarly, stem-loop IV sequence of hairpin ribozymes listed in Tables VI and VII (5'-CACGUUGUG-3') can be altered (substitution, deletion and/or
10 insertion) to contain any sequence provided, a minimum of two base-paired stem structure can form. The sequences listed in Tables III, V - VII may be formed of ribonucleotides or other nucleotides or non-nucleotides. Such ribozymes are equivalent to the ribozymes described specifically in the Tables.

Optimizing Ribozyme Activity

15 Ribozyme activity can be optimized as described by Stinchcomb *et al.*, supra. The details will not be repeated here, but include altering the length of the ribozyme binding arms (stems I and III, see Figure 2c), or chemically synthesizing ribozymes with modifications that prevent their degradation by serum ribonucleases (see *e.g.*, Eckstein *et al.*, International Publication
20 No. WO 92/07065; Perrault *et al.*, 1990 Nature 344, 565; Pieken *et al.*, 1991 Science 253, 314; Usman and Cedergren, 1992 Trends in Biochem. Sci. 17, 334; Usman *et al.*, International Publication No. WO 93/15187; and Rossi *et al.*, International Publication No. WO 91/03162, as well as Usman, N. *et al.* US Patent Application 07/829,729, and Sproat, European
25 Patent Application 92110298.4 and U.S. Patent 5,334,711 and Jennings *et al.*, WO 94/13688, which describe various chemical modifications that can be made to the sugar moieties of enzymatic RNA molecules. All these publications are hereby incorporated by reference herein.), modifications which enhance their efficacy in cells, and removal of stem II bases to
30 shorten RNA synthesis times and reduce chemical requirements.

Sullivan, *et al.*, supra, describes the general methods for delivery of enzymatic RNA molecules. Ribozymes may be administered to cells by a variety of methods known to those familiar to the art, including, but not restricted to, encapsulation in liposomes, by iontophoresis, or by
35 incorporation into other vehicles, such as hydrogels, cyclodextrins, biodegradable nanocapsules, and bioadhesive microspheres. The

RNA/vehicle combination is locally delivered by direct injection or by use of a catheter, infusion pump or stent. Alternative routes of delivery include, but are not limited to, intravenous injection, intramuscular injection, subcutaneous injection, aerosol inhalation, oral (tablet or pill form), topical, systemic, ocular, intraperitoneal and/or intrathecal delivery. More detailed descriptions of ribozyme delivery and administration are provided in Sullivan, et al., supra and Draper, et al., supra which have been incorporated by reference herein.

Another means of accumulating high concentrations of a ribozyme(s) within cells is to incorporate the ribozyme-encoding sequences into a DNA expression vector. Transcription of the ribozyme sequences are driven from a promoter for eukaryotic RNA polymerase I (pol I), RNA polymerase II (pol II), or RNA polymerase III (pol III). Transcripts from pol II or pol III promoters will be expressed at high levels in all cells; the levels of a given pol II promoter in a given cell type will depend on the nature of the gene regulatory sequences (enhancers, silencers, etc.) present nearby. Prokaryotic RNA polymerase promoters are also used, providing that the prokaryotic RNA polymerase enzyme is expressed in the appropriate cells (Elroy-Stein and Moss, 1990 Proc. Natl. Acad. Sci. U S A, 87, 6743-7; Gao and Huang 1993 Nucleic Acids Res., 21, 2867-72; Lieber et al., 1993 Methods Enzymol., 217, 47-66; Zhou et al., 1990 Mol. Cell. Biol., 10, 4529-37). Several investigators have demonstrated that ribozymes expressed from such promoters can function in mammalian cells (e.g. Kashani-Sabet et al., 1992 Antisense Res. Dev., 2, 3-15; Ojwang et al., 1992 Proc. Natl. Acad. Sci. U S A, 89, 10802-6; Chen et al., 1992 Nucleic Acids Res., 20, 4581-9; Yu et al., 1993 Proc. Natl. Acad. Sci. U S A, 90, 6340-4; L'Huillier et al., 1992 EMBO J. 11, 4411-8; Lisziewicz et al., 1993 Proc. Natl. Acad. Sci. U. S. A., 90, 8000-4). The above ribozyme transcription units can be incorporated into a variety of vectors for introduction into mammalian cells, including but not restricted to, plasmid DNA vectors, viral DNA vectors (such as adenovirus or adeno-associated virus vectors), or viral RNA vectors (such as retroviral, Sindbis virus, Semliki forest virus vectors).

In a preferred embodiment of the invention, a transcription unit expressing a ribozyme that cleaves apo(a) RNA is inserted into a plasmid DNA vector, a retrovirus DNA viral vector, an adenovirus DNA viral vector or an adeno-associated virus vector. These and other vectors have been

used to transfer genes to live animals (for a review see Friedman, 1989 Science 244, 1275-1281; Roemer and Friedman, 1992 Eur. J. Biochem. 208, 211-225) and leads to transient or stable gene expression. The vectors are delivered as recombinant viral particles. DNA may be delivered alone or complexed with vehicles (as described for RNA above). The DNA, DNA/vehicle complexes, or the recombinant virus particles are locally administered to the site of treatment, *e.g.*, through the use of a catheter, stent or infusion pump.

Example 1: apo(a) Hammerhead ribozymes

By engineering ribozyme motifs we have designed several ribozymes directed against apo(a) mRNA sequences. These have been synthesized with modifications that improve their nuclease resistance. These ribozymes cleave apo(a) target sequences *in vitro*.

The ribozymes will be tested for function *in vivo* by exogenous delivery to cells expressing apo(a). Ribozymes are delivered by incorporation into liposomes, by complexing with cationic lipids, by microinjection, or by expression from DNA vectors. Expression of apo(a) is monitored by ELISA, by indirect immunofluorescence, and/or by FACS analysis. Levels of apo(a) mRNA are assessed by Northern analysis, RNase protection, by primer extension analysis or by quantitative RT-PCR techniques. Ribozymes that block the induction of apo(a) protein and mRNA by more than 90% are identified.

Diagnostic uses

Ribozymes of this invention may be used as diagnostic tools to examine genetic drift and mutations within diseased cells. The close relationship between ribozyme activity and the structure of the target RNA allows the detection of mutations in any region of the molecule which alters the base-pairing and three-dimensional structure of the target RNA. By using multiple ribozymes described in this invention, one may map nucleotide changes which are important to RNA structure and function *in vitro*, as well as in cells and tissues. Cleavage of target RNAs with ribozymes may be used to inhibit gene expression and define the role (essentially) of specified gene products in the progression of disease. In this manner, other genetic targets may be defined as important mediators of the disease. These experiments will lead to better treatment of the

disease progression by affording the possibility of combinational therapies (e.g., multiple ribozymes targeted to different genes, ribozymes coupled with known small molecule inhibitors, or intermittent treatment with combinations of ribozymes and/or other chemical or biological molecules).

5 Other in vitro uses of ribozymes of this invention are well known in the art, and include detection of the presence of mRNA associated with an apo(a) related condition. Such RNA is detected by determining the presence of a cleavage product after treatment with a ribozyme using standard methodology.

10 In a specific example, ribozymes which can cleave only wild-type or mutant forms of the target RNA are used for the assay. The first ribozyme is used to identify wild-type RNA present in the sample and the second ribozyme will be used to identify mutant RNA in the sample. As reaction controls, synthetic substrates of both wild-type and mutant RNA will be
15 cleaved by both ribozymes to demonstrate the relative ribozyme efficiencies in the reactions and the absence of cleavage of the "non-targeted" RNA species. The cleavage products from the synthetic substrates will also serve to generate size markers for the analysis of wild-type and mutant RNAs in the sample population. Thus each analysis will
20 require two ribozymes, two substrates and one unknown sample which will be combined into six reactions. The presence of cleavage products will be determined using an RNase protection assay so that full-length and cleavage fragments of each RNA can be analyzed in one lane of a polyacrylamide gel. It is not absolutely required to quantify the results to
25 gain insight into the expression of mutant RNAs and putative risk of the desired phenotypic changes in target cells. The expression of mRNA whose protein product is implicated in the development of the phenotype (i.e., apo(a)) is adequate to establish risk. If probes of comparable specific activity are used for both transcripts, then a qualitative comparison of RNA
30 levels will be adequate and will decrease the cost of the initial diagnosis. Higher mutant form to wild-type ratios will be correlated with higher risk whether RNA levels are compared qualitatively or quantitatively.

Other embodiments are within the following claims.

TABLE ICharacteristics of Ribozymes**Group I Introns**

Size: ~200 to >1000 nucleotides.

Requires a U in the target sequence immediately 5' of the cleavage site.

Binds 4-6 nucleotides at 5' side of cleavage site.

Over 75 known members of this class. Found in *Tetrahymena thermophila* rRNA, fungal mitochondria, chloroplasts, phage T4, blue-green algae, and others.

RNAseP RNA (M1 RNA)

Size: ~290 to 400 nucleotides.

RNA portion of a ribonucleoprotein enzyme. Cleaves tRNA precursors to form mature tRNA.

Roughly 10 known members of this group all are bacterial in origin.

Hammerhead Ribozyme

Size: ~13 to 40 nucleotides.

Requires the target sequence UH immediately 5' of the cleavage site.

Binds a variable number nucleotides on both sides of the cleavage site.

14 known members of this class. Found in a number of plant pathogens (virusoids) that use RNA as the infectious agent (Figures 1 and 2)

Hairpin Ribozyme

Size: ~50 nucleotides.

Requires the target sequence GUC immediately 3' of the cleavage site.

Binds 4-6 nucleotides at 5' side of the cleavage site and a variable number to the 3' side of the cleavage site.

Only 3 known member of this class. Found in three plant pathogen (satellite RNAs of the tobacco ringspot virus, **arabis mosaic virus** and **chicory yellow mottle virus**) which uses RNA as the infectious agent (Figure 3).

Hepatitis Delta Virus (HDV) Ribozyme

Size: 50 - 60 nucleotides (at present).

Cleavage of target RNAs recently demonstrated.

Sequence requirements not fully determined.

Binding sites and structural requirements not fully determined, although no sequences 5' of cleavage site are required.

Only 1 known member of this class. Found in human HDV (Figure 4).

17

***Neurospora* VS RNA Ribozyme**

Size: ~144 nucleotides (at present)

Cleavage of target RNAs recently demonstrated.

Sequence requirements not fully determined.

Binding sites and structural requirements not fully determined. Only 1 known member of this class. Found in *Neurospora* VS RNA (Figure 5).

Table II: Unique Human apo(a) HH Target sequence

nt Position	HH Target Sequence	nt Position	HH Target Sequence
127	CCAGGAU U GCUACCA	11186	ACAGAAU A UUAUCCA
151	ACAGAGU U AUCCGAGG	11254	UUGGUGU U AUACCAU
154	GAGUUUAU C GAGGCAC	11257	GUGUUUAU A CCAUGGA
199	CCAAGCU U GGUCAUC	11266	CAUGGAU C CCAUGU
362	CAAUGCU C AGACGCA	11305	ACAAUGU C CAGUGAC
400	GACUGUU A CCCCGGU	11347	GGCUGUU U CUGAACA
408	CCCGGU U CCAAGCC	11348	GCUGUUU C UGAACAA
409	CCCGGUU C CAAGCCU	11423	CGAGGCU C AUUCUCC
417	CAAGCCU A GAGGCUC	11427	GCUCAUU C UCCACCA
481	CCAUGGU A AUGGACA	11429	UCAUUCU C CACCACU
571	GCAUAGU C GGACCCC	11440	CACUGUU A CAGGAAG
9031	CCACGGU A AUGGACA	11653	CACAACU C CCACGGU
10207	UCCAGAU C CUGUGGC	11670	UCCCAGU U CCAAGCA
10222	AGCCCCU U AUUGUUA	11779	CACCACU A UCACAGG
10223	GCCCCUU A UUGUUUAU	11797	AACAUGU C AGUCUUG
10225	CCCUUAU U GUUAUAC	11824	ACCACAU U GGCAUCG
10345	GGCUCCU U CUGAACA	11988	GUGUCCU C ACAACUC
10346	GCUCCUU C UGAACAA	12013	CCCGGUU C CAAGCAC
10532	AAGAACU A CUGCCGA	12159	CUAUGAU A CCACACU
10543	CCGAAAU C CAGAUGC	12235	UCCAGAU U CUGGGAA
10564	AGCCCCU U GGUGUUA	12236	CCAGAUU C UGGGAAA
10570	UUGGUGU U AUACAAC	12320	ACAGAAU C AGGUGUC
10622	CGAUGCU C AGAUGCA	12327	CAGGUGU C CUAGAGA
10677	CAAGCCU A GAGGCUU	12330	GUGUCCU A GAGACUC
10687	GGCUUUU U UUGAACA	12337	AGAGACU C CCACUGU
10736	UGCUAU A CCAUUUAU	12374	GCUCAUU C UGAAGCA
10741	CUACCAU U AUGGACA	12453	GCACAUU C UCCACCA
10742	UACCAUU A UGGACAG	12481	GACAUGU C AAUCUUG
10792	AAGAACU U GCCAAGC	12592	AGGCCCU U GGUGUUU
10828	CCAGCAU A GUCGGAC	12650	CGAUGCU C AGACACA
10899	CUGAGAU U CGCCCUU	12974	GCAUCCU C UUCAUUU
10900	UGAGAUU C GCCCUUG	12976	AUCCUCU U CAUUUGA
10906	UCGCCCU U GGUGUUA	13119	GCACCUU A AUAUCCC
10924	CAUGGAU C CCAGUGU	13226	CUCGAAU C UCAUGUU
10976	ACAGAAU C AAGUGUC	13228	CGAAUCU C AUGUUA
10983	CAAGUGU C CUUGCAA	13839	UGGUUUU U UUGUGUA
10986	GUGUCCU U GCAACUC	13848	UGUGUAU A AGCUUUU
11011	CCCAGAU C CAAGCAC	13930	ACUUUAU U UGAUUUG
11098	GAGUUUAU C GAGGCUC	13931	CUUAUUU U GAUUUGA
11170	CUGGCAU C AGAGGAC		

Table III: Unique Human apo(a) HH Ribozyme Sequence

nt. Position	Human apo (a) HH Ribozyme Sequence
127	UGGUAGC CUGAUGAGGCCGAAAGGCCGAA AUCCUGG
151	CCUCGAU CUGAUGAGGCCGAAAGGCCGAA ACUCUGU
154	GUGCCUC CUGAUGAGGCCGAAAGGCCGAA AUAACUC
199	GAUGACC CUGAUGAGGCCGAAAGGCCGAA AGCUUGG
362	UGCGUCU CUGAUGAGGCCGAAAGGCCGAA AGCAUUG
400	ACCGGGG CUGAUGAGGCCGAAAGGCCGAA AACAGUC
408	GGCUUGG CUGAUGAGGCCGAAAGGCCGAA ACCGGGG
409	AGGCUUG CUGAUGAGGCCGAAAGGCCGAA AACCGGG
417	GAGCCUC CUGAUGAGGCCGAAAGGCCGAA AGGCUUG
481	UGUCCAU CUGAUGAGGCCGAAAGGCCGAA ACCAUGG
571	GGGUCC CUGAUGAGGCCGAAAGGCCGAA ACUAUGC
9031	UGUCCAU CUGAUGAGGCCGAAAGGCCGAA ACCGUGG
10207	GCCACAG CUGAUGAGGCCGAAAGGCCGAA AUCUGGA
10222	UAACAAU CUGAUGAGGCCGAAAGGCCGAA AGGGGCU
10223	AUAACAA CUGAUGAGGCCGAAAGGCCGAA AAGGGGC
10225	GUAUAAC CUGAUGAGGCCGAAAGGCCGAA AUAAGGG
10345	UGUUCAG CUGAUGAGGCCGAAAGGCCGAA AGGAGCC
10346	UUGUUCA CUGAUGAGGCCGAAAGGCCGAA AAGGAGC
10532	UCGGCAG CUGAUGAGGCCGAAAGGCCGAA AGUUCUU
10543	GGAUCUG CUGAUGAGGCCGAAAGGCCGAA AUUUCGG
10564	UAACACC CUGAUGAGGCCGAAAGGCCGAA AGGGGCU
10570	GUUGUAU CUGAUGAGGCCGAAAGGCCGAA ACACCAA
10622	UGCAUCU CUGAUGAGGCCGAAAGGCCGAA AGCAUCG
10677	AAGCCUC CUGAUGAGGCCGAAAGGCCGAA AGGCUUG
10687	UGUUCAA CUGAUGAGGCCGAAAGGCCGAA AAAAGCC
10736	AUAUUGG CUGAUGAGGCCGAAAGGCCGAA AGUAGCA
10741	UGUCCAU CUGAUGAGGCCGAAAGGCCGAA AUGGUAG
10742	CUGUCCA CUGAUGAGGCCGAAAGGCCGAA AAUGGUA
10792	GCUUGGC CUGAUGAGGCCGAAAGGCCGAA AGUUCUU
10828	GUCCGAC CUGAUGAGGCCGAAAGGCCGAA AUGCUGG
10899	AAGGGCG CUGAUGAGGCCGAAAGGCCGAA AUCUCAG
10900	CAAGGGC CUGAUGAGGCCGAAAGGCCGAA AAUCUCA
10906	UAACACC CUGAUGAGGCCGAAAGGCCGAA AGGGCGA
10924	ACACUGG CUGAUGAGGCCGAAAGGCCGAA AUCCAUG
10976	GACACTU CUGAUGAGGCCGAAAGGCCGAA AUUCUGU
10983	UUGCAAG CUGAUGAGGCCGAAAGGCCGAA ACACUUG
10986	GAGUUGC CUGAUGAGGCCGAAAGGCCGAA AGGACAC
11011	GUGCUU CUGAUGAGGCCGAAAGGCCGAA AUCUGGG
11098	GAGCCU CUGAUGAGGCCGAAAGGCCG AUAACUC
11170	GUCCUC CUGAUGAGGCCGAAAGGCCG . AUGCCAG
11186	UGGAUA CUGAUGAGGCCGAAAGGCCGAA AUUCUGU
11254	AUGGUUAU CUGAUGAGGCCGAAAGGCCGAA ACACCAA
11257	UCCAUGG CUGAUGAGGCCGAAAGGCCGAA AUAACAC
11266	ACAUUGG CUGAUGAGGCCGAAAGGCCGAA AUCCAUG

11305 GUCACUG CUGAUGAGGCCGAAAGGCCGAA ACAUUGU
11347 UGUUCAG CUGAUGAGGCCGAAAGGCCGAA AACAGCC
11348 UUGUUCA CUGAUGAGGCCGAAAGGCCGAA AACAGC
11423 GGAGAAU CUGAUGAGGCCGAAAGGCCGAA AGCCUCG
11427 UGGUGGA CUGAUGAGGCCGAAAGGCCGAA AAUGAGC
11429 AGUGGUG CUGAUGAGGCCGAAAGGCCGAA AGAAUGA
11440 CUUCCUG CUGAUGAGGCCGAAAGGCCGAA AACAGUG
11653 ACCGUGG CUGAUGAGGCCGAAAGGCCGAA AGUUGUG
11670 UGCUUGG CUGAUGAGGCCGAAAGGCCGAA ACUGGGA
11779 CCUGUGA CUGAUGAGGCCGAAAGGCCGAA AGUGGUG
11797 CAAGACU CUGAUGAGGCCGAAAGGCCGAA ACAUGUU
11824 CGAUGCC CUGAUGAGGCCGAAAGGCCGAA AUGUGGU
11988 GAGUUGU CUGAUGAGGCCGAAAGGCCGAA AGGACAC
12013 GUGCUUG CUGAUGAGGCCGAAAGGCCGAA AACCGGG
12159 AGUGUGG CUGAUGAGGCCGAAAGGCCGAA AUCAUAG
12235 UUCCCAG CUGAUGAGGCCGAAAGGCCGAA AUCUGGA
12236 UUUCCCA CUGAUGAGGCCGAAAGGCCGAA AAUCUGG
12320 GACACCU CUGAUGAGGCCGAAAGGCCGAA AUUCUGU
12327 UCUCUAG CUGAUGAGGCCGAAAGGCCGAA ACACCUG
12330 GAGUCUC CUGAUGAGGCCGAAAGGCCGAA AGGACAC
12337 ACAGUGG CUGAUGAGGCCGAAAGGCCGAA AGUCUCU
12374 UGCUUCA CUGAUGAGGCCGAAAGGCCGAA AAUGAGC
12453 UGGUGGA CUGAUGAGGCCGAAAGGCCGAA AAUGUGC
12481 CAAGAUU CUGAUGAGGCCGAAAGGCCGAA ACAUGUC
12592 AAACACC CUGAUGAGGCCGAAAGGCCGAA AGGGCTU
12650 UGUGUCU CUGAUGAGGCCGAAAGGCCGAA AGCAUCG
12974 AAAUGAA CUGAUGAGGCCGAAAGGCCGAA AGGAUGC
12976 UCAAAUG CUGAUGAGGCCGAAAGGCCGAA AGAGGAU
13119 GGGAUAU CUGAUGAGGCCGAAAGGCCGAA AAGGUGC
13226 AACAUGA CUGAUGAGGCCGAAAGGCCGAA AUUCGAG
13228 UGAACAU CUGAUGAGGCCGAAAGGCCGAA AGAUUCG
13839 UACACAA CUGAUGAGGCCGAAAGGCCGAA AAUACCA
13848 AAAAGCU CUGAUGAGGCCGAAAGGCCGAA AUACACA
13930 CAAAUCA CUGAUGAGGCCGAAAGGCCGAA AAUAAGU
13931 UCAAAUC CUGAUGAGGCCGAAAGGCCGAA AAAUAAG

Table IV: Unique Monkey apo(a) HH Target Sequence

nt. Position	HH Target Sequence	nt. Position	HH Target Sequence
127	CUGCCGU C GCaCCUC	11170	ACAaUgU C UGGugAC
151	CUGCCGU C GCaCCUC	11186	ACAGAAU C AAGUGUC
154	CUGCCgU C GcaCCUC	11254	gCUUcUU c UgaAGAA
199	CCCCGGU U CCAAGCC	11257	GACUGCU A CCAUGGU
362	AGAGGCU C CUUCCGA	11266	GAGUUAU C GAGGCUC
400	GGCUCCU U CCGAACA	11305	CGAGGCU C AUUCUCC
408	GGCUCCU U CCGAACA	11347	UCAUUCU C CACCACU
409	GGCUCCU U CCGAACA	11348	GACAUGU C AGUCUUG
417	GGCUCCU U CCGAACA	11423	UCUUGGU C CUCUAUG
481	GCUCCUU C CGAACAA	11427	UGGUCCU C UAUGACA
571	ACAGAGU U AUCGAGG	11429	UGGUCCU C UAUGACA
9031	GAGUUAU C GAGGCac	11440	GUCCUCU A UGACACC
10207	CCACACU C uCAUAGU	11653	auAGAAU A CUACCCA
10222	CCACACU C uCAUAGU	11670	auAGAAU A CUA DCCA
10223	AGAGGCU C CUUCUGA	11779	aUGgAaJ c AaGUGUC
10225	AGAGGCU c CUUCUGA	11797	CAAGUCU C CUUGCaA
10345	GUGUUAU A CAACgGA	11824	UCCCAU U CCAAGCA
10346	AACgGAU C CCAGUGU	11988	UcGGCAU C GGAGGAU
10532	AGaGGcU u UUCUuga	12013	UCCCAUU A cgCUAUC
10543	AGAGGCU U UUcUUGA	12159	GCUCCUU C UGAACAA
10564	GAGGCuU u UCuUgaA	12235	CCAGGAU U GCUACCA
10570	AGGCUUU U cUUGAAC	12236	CCAGGAU U GCUACCA
10622	UgCUACU a CcaUUUAU	12320	gaACUGU c aGUcUuG
10677	GGCACAU A CUCCACC	12327	UCUUGGU C AUCUAUG
10687	CCACUGU u ACAGGAA	12330	UGGUCAU C UAUGAU
10736	ccACUGU u ACAGGAA	12337	GUCAUCU A UGAUACC
10741	CCACUGU u ACAGGAA	12374	UGGUGUU A CACgACu
10742	CCACUGU u ACAGGAA	12453	AgagaCU c CCACUGU
10792	CACUGUU A CaGGaAg	12481	CUGUUGU U CCgGUUC
10828	GCAUAGU C GGaCCCC	12592	GCUCAUU C UGAAGCA
10899	GCAUAGU C GGaCCCC	12650	UCAUUCU U GGUCAUC
10900	GCAUAGU C GGaCCCC	12974	CCACAUU C CUGGCCC
10906	AaAaACU a UGaaAu	12976	GGCAAGU C AGUCUaA
10924	CAGGAAU C CAGAUGC	13119	AgGccuU c CUUCUAC
10976	CAGGAAU C CAGAUGC	13226	AGUGUCU A GGuUGUU
10983	CAGGAAU C CAGAUGC	13228	aGuGUCU a GGuUGUu
10986	CAGGAAU C CAGAUGC	13839	UGGUAAU a UUGUGUA
11011	CAGGAAU C CAGAUGC	13848	UAAGCUU U UcccGUC
11098	UcGcCCU U GGUCUA		

Table V: Unique Monkey apo(a) HH Ribozyme Sequence

nt. Position	Monkey HH Ribozyme Sequence
127	GAGGUGC CUGAUGAGGCCGAAAGGCCGAA ACGGCAG
151	GAGGUGC CUGAUGAGGCCGAAAGGCCGAA ACGGCAG
154	GAGGUGC CUGAUGAGGCCGAAAGGCCGAA ACGGCAG
199	GGCUUGG CUGAUGAGGCCGAAAGGCCGAA ACCGGGG
362	UCGGAAG CUGAUGAGGCCGAAAGGCCGAA AGCCUCU
400	UGUUCGG CUGAUGAGGCCGAAAGGCCGAA AGGAGCC
408	UGUUCGG CUGAUGAGGCCGAAAGGCCGAA AGGAGCC
409	UGUUCGG CUGAUGAGGCCGAAAGGCCGAA AGGAGCC
417	UGUUCGG CUGAUGAGGCCGAAAGGCCGAA AGGAGCC
481	UUGUUCG CUGAUGAGGCCGAAAGGCCGAA AAGGAGC
571	CCUCGAU CUGAUGAGGCCGAAAGGCCGAA ACUCUGU
9031	GUGCCUC CUGAUGAGGCCGAAAGGCCGAA AUAACUC
10207	ACUAUGA CUGAUGAGGCCGAAAGGCCGAA AGUGUGG
10222	ACUAUGA CUGAUGAGGCCGAAAGGCCGAA AGUGUGG
10223	UCAGAAG CUGAUGAGGCCGAAAGGCCGAA AGCCUCU
10225	UCAGAAG CUGAUGAGGCCGAAAGGCCGAA AGCCUCU
10345	UCCGUUG CUGAUGAGGCCGAAAGGCCGAA AUAACAC
10346	ACACUGG CUGAUGAGGCCGAAAGGCCGAA AUCCGUU
10532	UCAAGAA CUGAUGAGGCCGAAAGGCCGAA AGCCUCU
10543	UCAAGAA CUGAUGAGGCCGAAAGGCCGAA AGCCUCU
10564	UUCAAGA CUGAUGAGGCCGAAAGGCCGAA AAGCCUC
10570	GUUCAAG CUGAUGAGGCCGAAAGGCCGAA AAAGCCU
10622	AUAAUGG CUGAUGAGGCCGAAAGGCCGAA AGUAGCA
10677	GGUGGAG CUGAUGAGGCCGAAAGGCCGAA AUGUGCC
10687	UUCUGU CUGAUGAGGCCGAAAGGCCGAA ACAGUGG
10736	UUCUGU CUGAUGAGGCCGAAAGGCCGAA ACAGUGG
10741	UUCUGU CUGAUGAGGCCGAAAGGCCGAA ACAGUGG
10742	UUCUGU CUGAUGAGGCCGAAAGGCCGAA ACAGUGG
10792	CUUCCUG CUGAUGAGGCCGAAAGGCCGAA AACAGUG
10828	GGGUCC CUGAUGAGGCCGAAAGGCCGAA ACUAUGC
10899	GGGUCC CUGAUGAGGCCGAAAGGCCGAA ACUAUGC
10900	GGGUCC CUGAUGAGGCCGAAAGGCCGAA ACUAUGC
10906	AUUUGGA CUGAUGAGGCCGAAAGGCCGAA AGUUUUU
10924	GCAUCUG CUGAUGAGGCCGAAAGGCCGAA AUUCCUG
10976	GCAUCUG CUGAUGAGGCCGAAAGGCCGAA AUUCCUG
10983	GCAUCUG CUGAUGAGGCCGAAAGGCCGAA AUUCCUG
10986	GCAUCUG CUGAUGAGGCCGAAAGGCCGAA AUUCCUG
11011	GCAUCUG CUGAUGAGGCCGAAAGGCCGAA AUUCCUG
11098	UAACACC CUGAUGAGGCCGAAAGGCCGAA AGGGCGA
11170	GUCACCA CUGAUGAGGCCGAAAGGCCGAA ACAUUGU
11186	GACACUU CUGAUGAGGCCGAAAGGCCGAA AUUCUGU
11254	UUCUUCA CUGAUGAGGCCGAAAGGCCGAA AAGAAGC
11257	ACCAUGG CUGAUGAGGCCGAAAGGCCGAA AGCAGUC
11266	GAGCCUC CUGAUGAGGCCGAAAGGCCGAA AUAACUC

11305 GGAGAAU CUGAUGAGGCCGAAAGGCCGAA AGCCTUCG
11347 AGUGGUG CUGAUGAGGCCGAAAGGCCGAA AGAAUGA
11348 CAAGACU CUGAUGAGGCCGAAAGGCCGAA ACAUGUC
11423 CAUAGAG CUGAUGAGGCCGAAAGGCCGAA ACCAAGA
11427 UGUCAUA CUGAUGAGGCCGAAAGGCCGAA AGGACCA
11429 UGUCAUA CUGAUGAGGCCGAAAGGCCGAA AGGACCA
11440 GGUGUUA CUGAUGAGGCCGAAAGGCCGAA AGAGGAC
11653 UGGGUAG CUGAUGAGGCCGAAAGGCCGAA AUUCUAU
11670 UGGGUAG CUGAUGAGGCCGAAAGGCCGAA AUUCUAU
11779 GACACUU CUGAUGAGGCCGAAAGGCCGAA AUUCCAU
11797 UUGCAAG CUGAUGAGGCCGAAAGGCCGAA ACACUUG
11824 UGCUUGG CUGAUGAGGCCGAAAGGCCGAA ACUGGGA
11988 AUCCTCC CUGAUGAGGCCGAAAGGCCGAA AUGCCGA
12013 GAUAGCG CUGAUGAGGCCGAAAGGCCGAA AAUGGGA
12159 UUGUUCA CUGAUGAGGCCGAAAGGCCGAA AAGGACC
12235 UGGUAGC CUGAUGAGGCCGAAAGGCCGAA AUCCUGG
12236 UGGUAGC CUGAUGAGGCCGAAAGGCCGAA AUCCUGG
12320 CAAGACU CUGAUGAGGCCGAAAGGCCGAA ACAGUUC
12327 CAUAGAU CUGAUGAGGCCGAAAGGCCGAA ACCAAGA
12330 UAUCAUA CUGAUGAGGCCGAAAGGCCGAA AUGACCA
12337 GGUAUCA CUGAUGAGGCCGAAAGGCCGAA AGAUGAC
12374 AGUCGUG CUGAUGAGGCCGAAAGGCCGAA AACACCA
12453 ACAGUGG CUGAUGAGGCCGAAAGGCCGAA AGUCUCU
12481 GAACCGG CUGAUGAGGCCGAAAGGCCGAA ACAACAG
12592 UGCUUCA CUGAUGAGGCCGAAAGGCCGAA AAUGAGC
12650 GAUGACC CUGAUGAGGCCGAAAGGCCGAA AGAUUGA
12974 GGGCCAG CUGAUGAGGCCGAAAGGCCGAA AAUGUGG
12976 UAAGACU CUGAUGAGGCCGAAAGGCCGAA ACUUGCC
13119 GUAGAAG CUGAUGAGGCCGAAAGGCCGAA AAGGCTU
13226 AACCAAC CUGAUGAGGCCGAAAGGCCGAA AGACACU
13228 AACCAAC CUGAUGAGGCCGAAAGGCCGAA AGACACU
13839 UACACAA CUGAUGAGGCCGAAAGGCCGAA AAUACCA
13848 GACGGGA CUGAUGAGGCCGAAAGGCCGAA AAGCTUA

Table VI: Unique Human apo(a) Hairpin Ribozyme Sequence

nt. position	Hairpin Ribozyme Sequence	Substrate Sequence
378	GGCGGAC AGAA GUCC ACCAGAGAAACACACCGUUGUGGUACAUAUACCUUGUA	GGACU GCC GUCGGGCC
381	GGAGGCC AGAA GCAG ACCAGAGAAACACACCGUUGUGGUACAUAUACCUUGUA	CUGCC GUC GCGCCUCC
440	UUUGCUCA AGAA GUGC ACCAGAGAAACACACCGUUGUGGUACAUAUACCUUGUA	GCACC GAC UGAGCAAA
7964	UCUGCUCA AGAA GUGC ACCAGAGAAACACACCGUUGUGGUACAUAUACCUUGUA	GCACC GAC UGAGCAGA
10215	CAAUAAGG AGAA GCCA ACCAGAGAAACACACCGUUGUGGUACAUAUACCUUGUA	UGGCA GCC CCUUUAUUG
10534	UGGAUUUC AGAA GUAG ACCAGAGAAACACACCGUUGUGGUACAUAUACCUUGUA	CUACU GCC GAAAUCCA
10557	CACCAAGG AGAA GCCA ACCAGAGAAACACACCGUUGUGGUACAUAUACCUUGUA	UGGCA GCC CCUUGGUG
10638	GGGACGAA AGAA GUCC ACCAGAGAAACACACCGUUGUGGUACAUAUACCUUGUA	GGACU GCC UUCGUCCC
10700	UUUCCUCA AGAA GUGC ACCAGAGAAACACACCGUUGUGGUACAUAUACCUUGUA	GCACU GAC UGAGGAAA
11343	UGUUCAGA AGAA GCCG ACCAGAGAAACACACCGUUGUGGUACAUAUACCUUGUA	CGGCU GUU UCUGAACA
11379	CAGUCCUG AGAA GUGG ACCAGAGAAACACACCGUUGUGGUACAUAUACCUUGUA	CCACA GUC CAGGACUG
12342	ACUGGAAC AGAA GUGG ACCAGAGAAACACACCGUUGUGGUACAUAUACCUUGUA	CCACU GUU GUUCCAGU
12804	GGCUCCUG AGAA GCCC ACCAGAGAAACACACCGUUGUGGUACAUAUACCUUGUA	GGGCU GCC CAGGAGCC
12877	AGGGUAC AGAA GUAA ACCAGAGAAACACACCGUUGUGGUACAUAUACCUUGUA	UUACU GCC GUAACCCU
13139	GAGCAGCA AGAA GCAC ACCAGAGAAACACACCGUUGUGGUACAUAUACCUUGUA	GUGCU GAC UGCUGCUC
13256	GCUCCAAG AGAA GCCU ACCAGAGAAACACACCGUUGUGGUACAUAUACCUUGUA	AGGCU GUU CUUGGAGC
13522	ACCCUGGC AGAA GUCA ACCAGAGAAACACACCGUUGUGGUACAUAUACCUUGUA	UGACA GUU GCCAGGGU
13794	UAGCTUGG AGAA GUGU ACCAGAGAAACACACCGUUGUGGUACAUAUACCUUGUA	ACACU GUU CCCAGCTUA

Table VII: Unique Monkey apo(a) Hairpin Ribozyme Sequence

nt. Position	Hairpin Ribozyme Sequence	Substrate Sequence
57	GGUGGCAG AGAA GUCC ACCAGAGAAAACACACCGUUGUGGUACAUAUACCUUGGUA	GGACU GCC GUCCGACC
60	GGAGGUGC AGAA GCAG ACCAGAGAAAACACACCGUUGUGGUACAUAUACCUUGGUA	CUGCC GUC GCACCCUCC
119	UUUGCUCAG AGAA GUGC ACCAGAGAAAACACACCGUUGUGGUACAUAUACCUUGGUA	GCACC GAC UGAGCAAA
318	CAUAUAGG AGAA GCCA ACCAACAACAACACCGUUGUGGUACAUAUACCUUGGUA	UGGCA GCC CCUUAUUG
660	CAUAUAGG AGAA GCCA ACCAGAGAAAACACACCGUUGUGGUACAUAUACCUUGGUA	UGGCA GCC CCUUAUUG
744	GGAGGUGC AGAA GCAG ACCAGAGAAAACACACCGUUGUGGUACAUAUACCUUGGUA	CUGCA GUC GCACCCUCC
803	UUUGCUCAG AGAA GUGC ACCAGAGAAAACACACCGUUGUGGUACAUAUACCUUGGUA	GCACC GAC UGAGCAAA
1002	CAUAUAGG AGAA GCCA ACCAGAGAAAACACACCGUUGUGGUACAUAUACCUUGGUA	UGGCA GCC CCUUAUUG
1083	GGUGGCAG AGAA GUCC ACCAGAGAAAACACACCGUUGUGGUACAUAUACCUUGGUA	GGACU GCC GUCCGACC
1086	GGAGGUGC AGAA GCAG ACCAGAGAAAACACACCGUUGUGGUACAUAUACCUUGGUA	CUGCC GUC GCACCCUCC
1321	UGGAUUUC AGAA GUAG ACCAGAGAAAACACACCGUUGUGGUACAUAUACCUUGGUA	CUACU GCC GAAAUCCA
1344	CACCAAGG AGAA GCCA ACCAGAGAAAACACACCGUUGUGGUACAUAUACCUUGGUA	UGGCA GCC CCUUGGUG
2130	UGUUCAGA AGAA GCCA ACCAGAGAAAACACACCGUUGUGGUACAUAUACCUUGGUA	UGGCU GUU UCUGAACA
2500	GACCCACAG AGAA GUUU ACCAGAGAAAACACACCGUUGUGGUACAUAUACCUUGGUA	AAACA GCC CUGGGGUC
3129	ACCGGAC AGAA GUGG ACCAGAGAAAACACACCGUUGUGGUACAUAUACCUUGGUA	CCACU GUU GUUCCCGGU
3683	AAGCAGCA AGAA GCAC ACCAGAGAAAACACACCGUUGUGGUACAUAUACCUUGGUA	GUGCU GAC UGCUGCTUU
3890	AAUUUGGA AGAA GCAG ACCAGAGAAAACACACCGUUGUGGUACAUAUACCUUGGUA	CUGCC GUC UCCAAAUU
3912	UCAGUCCA AGAA GUGA ACCAGAGAAAACACACCGUUGUGGUACAUAUACCUUGGUA	UCACC GCC UGGACUGA
4465	UUGCUGGG AGAA GUGU ACCAGAGAAAACACACCGUUGUGGUACAUAUACCUUGGUA	ACACU GUC CCCAGCUA

Claims

1. An enzymatic RNA molecule which cleaves apo(a) mRNA .
2. An enzymatic RNA molecule of claim 1, the binding arms of which
5 contain sequences complementary to any one of the sequences defined in
any of those in Table II.
3. The enzymatic RNA molecule of claim 1, the binding arms of which
contain sequences complementary to the sequences defined in any one of
Tables IV, VI and VII
- 10 4. The enzymatic RNA molecule of claims 1, 2, or 3, wherein said
RNA molecule is in a hammerhead motif.
5. The enzymatic RNA molecule of claim 1, 2, or 3, wherein said RNA
molecule is in a hairpin, hepatitis delta virus, group 1 intron, *Neurospora*
VS RNA or RNaseP RNA motif.
- 15 6. The enzymatic RNA molecule of claim 5, wherein said ribozyme
comprises between 12 and 100 bases complementary to said mRNA.
7. The enzymatic RNA molecule of claim 6, wherein said ribozyme
comprises between 14 and 24 bases complementary to said mRNA.
8. Enzymatic RNA molecule consisting essentially of any sequence
20 selected from the group of those shown in Tables III, V, VI, and VII.
9. A mammalian cell including an enzymatic RNA molecule of claims
1, 2, or 3.
10. The cell of claim 8, wherein said cell is a human cell.
11. An expression vector including nucleic acid encoding an
25 enzymatic RNA molecule or multiple enzymatic molecules of claims 1, 2, or
3 in a manner which allows expression of that enzymatic RNA molecule(s)
within a mammalian cell.
12. A mammalian cell including an expression vector of claim 11.

13. The cell of claim 13, wherein said cell is a human cell.

14. A method for treatment of a condition related to elevated plasma Lp(a) levels by administering to a patient an enzymatic nucleic acid molecule of claims 1, 2, or 3,

5 15. A method for treatment of a condition related to elevated plasma Lp(a) levels by administering to a patient an expression vector of claim 11.

16. The method of claims 14 or 15, wherein said patient is a human.

17. The method of claim 15 wherein said condition is selected from the group consisting of atherosclerosis, myocardial infraction, stroke,
10 restenosis, and heart diseases.

18. The method of claim 17 wherein said condition is restenosis.

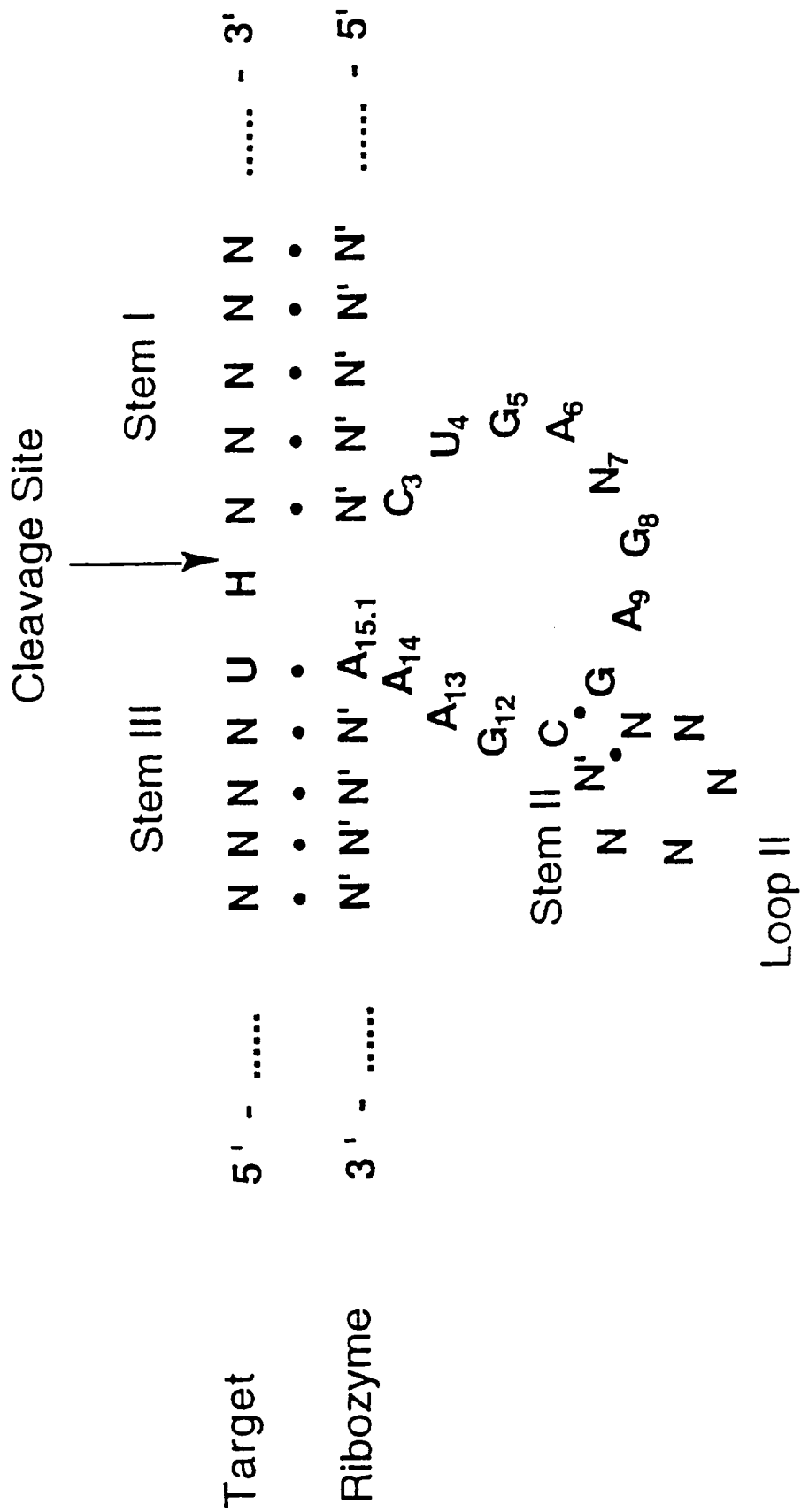
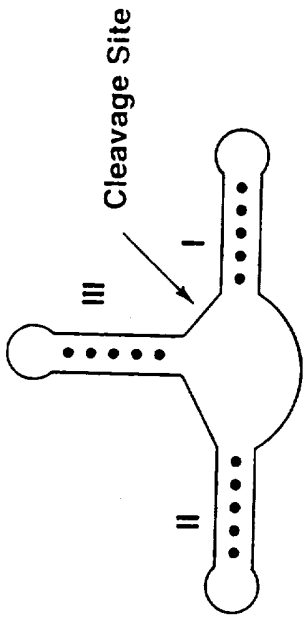

FIG. 1.

FIG. 2a.



a

FIG. 2b.

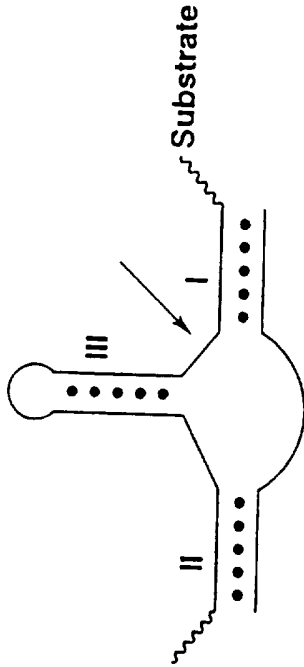

b

FIG. 2c.

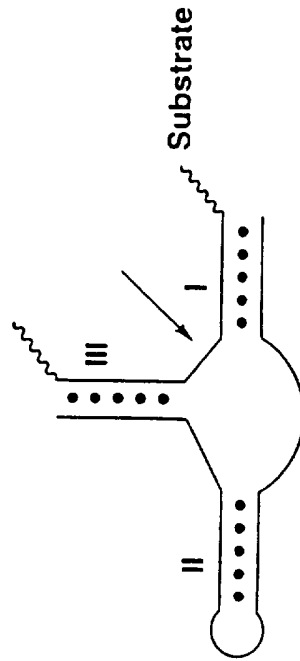

c

FIG. 2d.

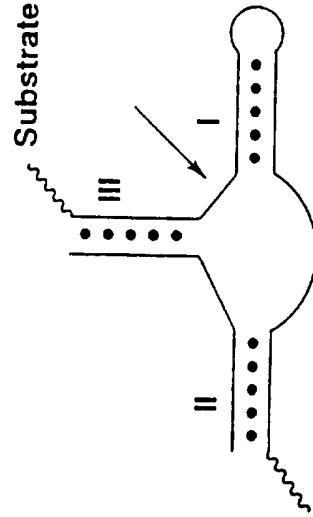

d

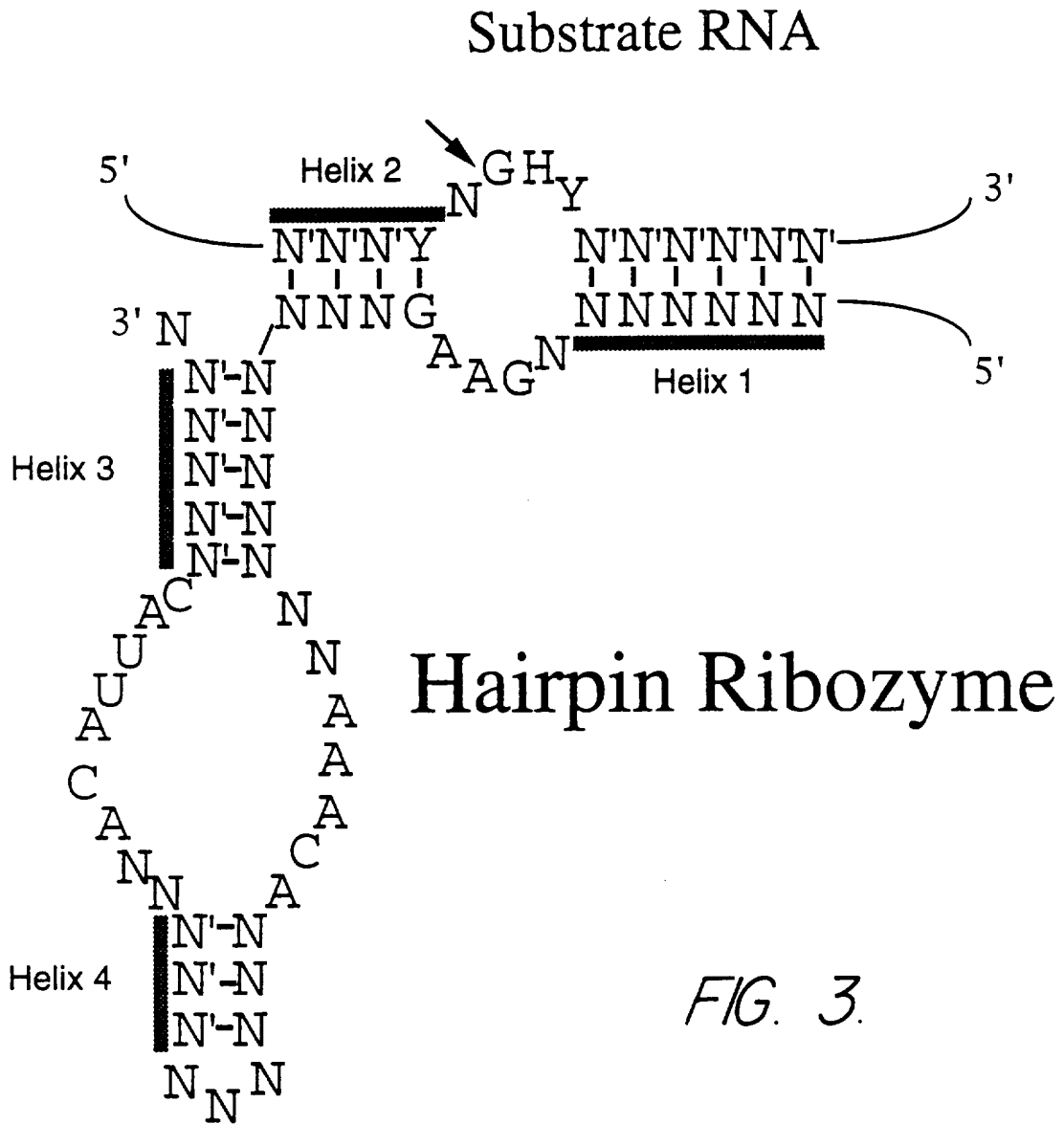

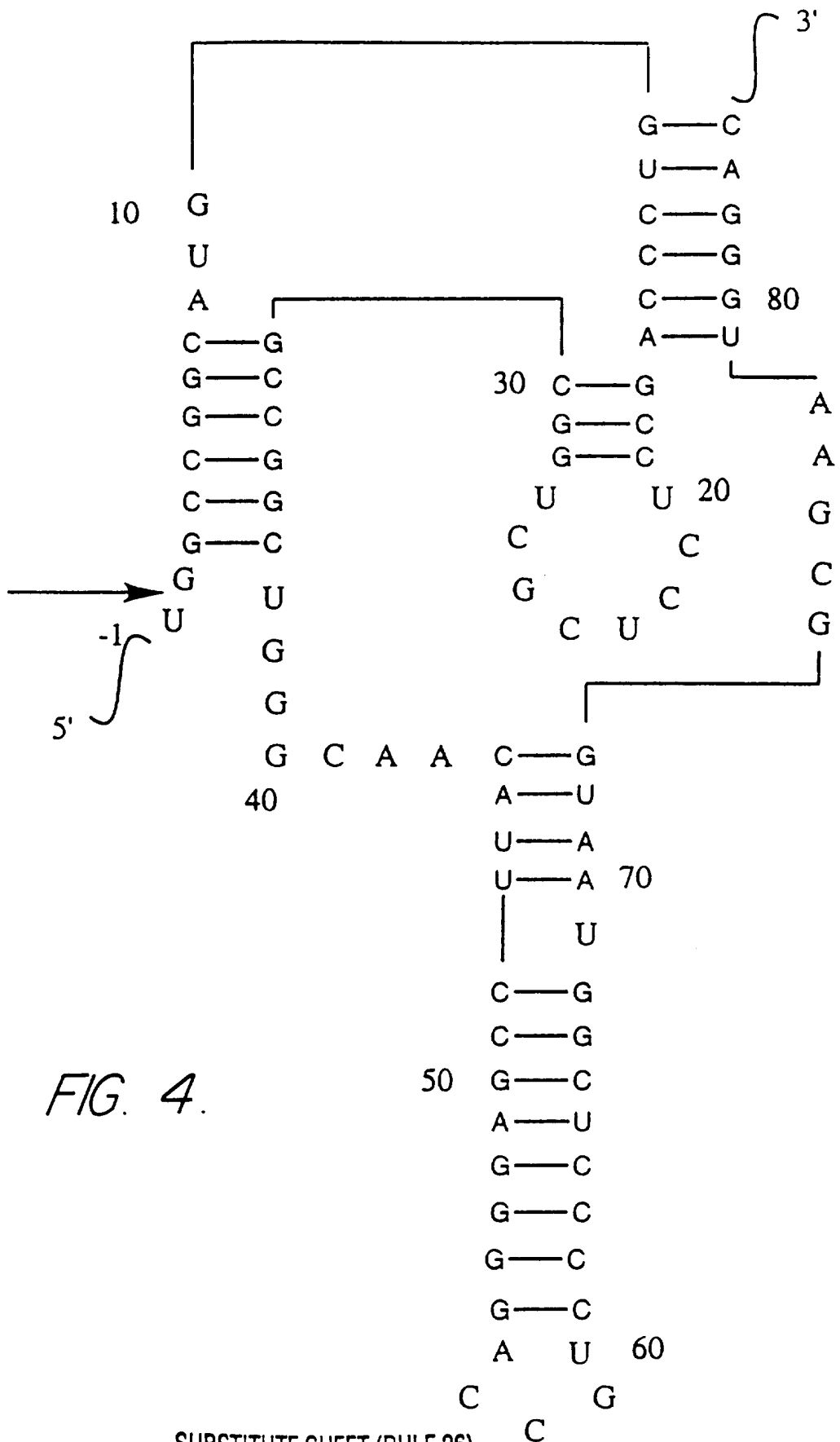
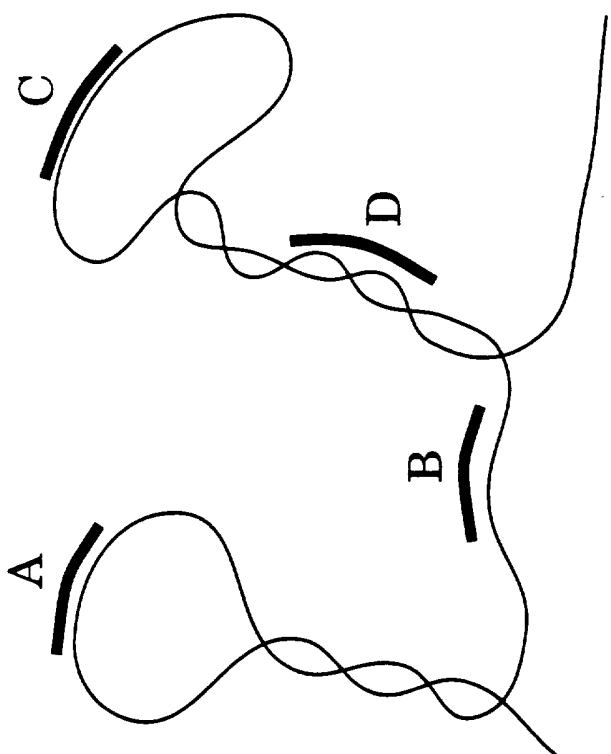
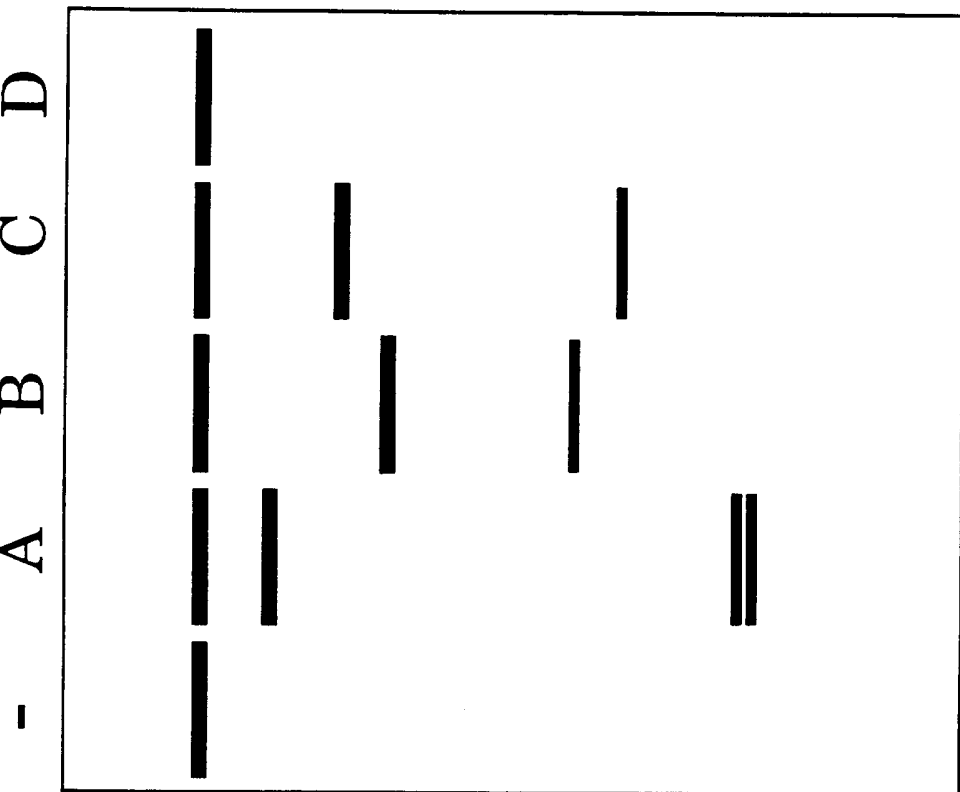

FIG. 4.

FIG. 6.



- Body-labeled transcript (not purified)
- DNA oligo (10 nM, 100 nM and 1000 nM)
- RNase H (0.08 - 1.0 w/ μ l)
- 37°C, 10 min

INTERNATIONAL SEARCH REPORT

International Application No
PCT/US 95/11995

A. CLASSIFICATION OF SUBJECT MATTER
IPC 6 C12N15/52 C12N9/00 A61K31/70 C12N5/10

According to International Patent Classification (IPC) or to both national classification and IPC

B. FIELDS SEARCHED

Minimum documentation searched (classification system followed by classification symbols)
IPC 6 C12N A61K

Documentation searched other than minimum documentation to the extent that such documents are included in the fields searched

Electronic data base consulted during the international search (name of data base and, where practical, search terms used)

C. DOCUMENTS CONSIDERED TO BE RELEVANT

Category *	Citation of document, with indication, where appropriate, of the relevant passages	Relevant to claim No.
A	NATURE, vol. 330, 12 November 1987 LONDON GB, pages 132-137, MCLEAN, J. ET AL. 'cDNA sequence of human apolipoprotein(a) is homologous to plasminogen' cited in the application see figure 1	1-3,8, 14-18
A	--- JOURNAL OF BIOLOGICAL CHEMISTRY, vol. 264, 5 April 1989 MD US, pages 5957-5965, TOMLINSON, J. ET AL. 'Rhesus monkey apolipoprotein(a)' cited in the application see figure 1 --- -/--	1-3,8, 14-18

Further documents are listed in the continuation of box C.

Patent family members are listed in annex.

* Special categories of cited documents :

- 'A' document defining the general state of the art which is not considered to be of particular relevance
- 'E' earlier document but published on or after the international filing date
- 'L' document which may throw doubts on priority claim(s) or which is cited to establish the publication date of another citation or other special reason (as specified)
- 'O' document referring to an oral disclosure, use, exhibition or other means
- 'P' document published prior to the international filing date but later than the priority date claimed

- 'T' later document published after the international filing date or priority date and not in conflict with the application but cited to understand the principle or theory underlying the invention
- 'X' document of particular relevance; the claimed invention cannot be considered novel or cannot be considered to involve an inventive step when the document is taken alone
- 'Y' document of particular relevance; the claimed invention cannot be considered to involve an inventive step when the document is combined with one or more other such documents, such combination being obvious to a person skilled in the art.
- '&' document member of the same patent family

Date of the actual completion of the international search

28 February 1996

Date of mailing of the international search report

06. 03. 96

Name and mailing address of the ISA

European Patent Office, P.B. 5818 Patentlaan 2
NL - 2280 HV Rijswijk
Tel. (+31-70) 340-2040, Tx. 31 651 epo nl,
Fax: (+31-70) 340-3016

Authorized officer

Andres, S

INTERNATIONAL SEARCH REPORT

International Application No
PCT/US 95/11995

C.(Continuation) DOCUMENTS CONSIDERED TO BE RELEVANT		
Category *	Citation of document, with indication, where appropriate, of the relevant passages	Relevant to claim No.
A	CURRENT OPINION IN STRUCTURAL BIOLOGY, vol. 4, June 1994 LONDON GB, pages 322-330, XP 000523747 SYMONS, R.H. 'Ribozymes' see the whole document ---	1-18
A	CIRCULATION, vol. 88, no. 3, September 1993 pages 935-940, MOLITERNO, D. ET AL. 'Relation of plasma lipoprotein(a) to infarct artery patency in survivors of myocardial infarction' cited in the application see the whole document -----	14-18