

C. P. RYTHER.  
Bark-Mill.

No. 220,945.

Patented Oct. 28, 1879.

*Fig. 1.*

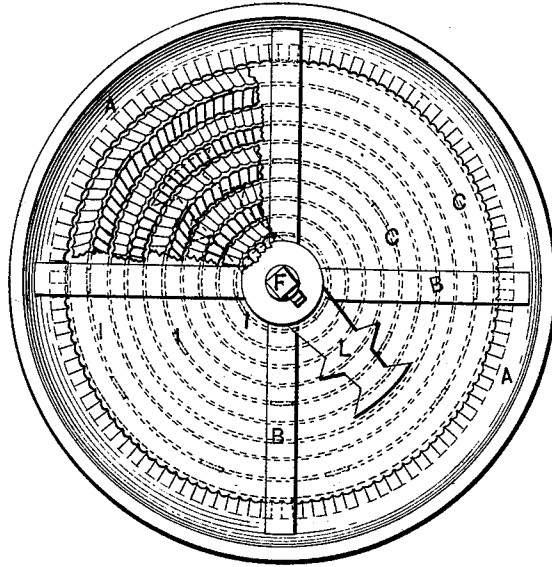

*Fig. 2.*

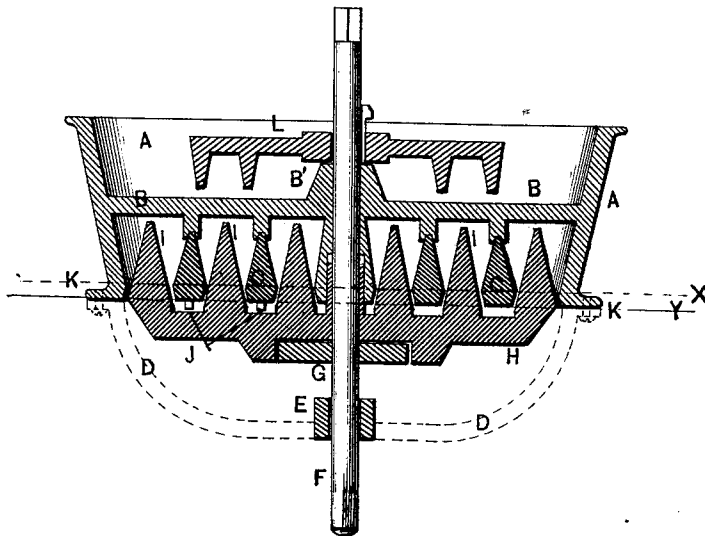

*Geo. W. Morrow*  
*J. B. House*  
Witnesses

*Chas. P. Ryther*  
Inventor

# UNITED STATES PATENT OFFICE.

CHARLES P. RYTHUR, OF CARTHAGE, NEW YORK.

## IMPROVEMENT IN BARK-MILLS.

Specification forming part of Letters Patent No. 220,945, dated October 28, 1879; application filed June 16, 1879.

*To all whom it may concern:*

Be it known that I, CHARLES P. RYTHUR, of Carthage, county of Jefferson, and State of New York, have invented a new and useful Improvement in Mills and Appliances for Crushing, Grinding, and Disintegrating Barks and Dried Vegetable Substances or Drugs, of which the following is a specification.

My invention consists in certain improvements hereinafter described, and more particularly pointed out in the claim.

In the accompanying drawings, in which similar letters of reference indicate like parts in each view, Figure 1 is a horizontal plan view from above, and Fig. 2 a vertical section taken through the center of the mill.

A A is a hopper-shaped shell, forming the body of the mill proper, and provided with ears at K' K', by which the same may be securely fastened to suitable timbers in the floor.

Running across the body of this shell, about midway of its depth, are the supports B B, which unite at the center in the hub B'. Depending from these supports are a number of annular rings, C C, the peculiar form of whose vertical section is that of a couple of truncated cones set base to base, the lower cone being much the shorter.

D is a stirrup-hanger attached to the shell A A, and carrying the sleeve E, through which passes the driving-shaft F. To the latter is firmly attached the armed clutch G, which engages with suitable lugs on the under side of the arms H H, and to whose upper sides are attached the series of annular rings, I I, the outline of whose vertical section is that of a cone with the base resting on the arm H.

The sloping faces of each of the series of annular rings C C and I I are serrated, as are also the surfaces of the lower portion of the interior of the shell A A and the exterior of the hub B', which extends down within the annular rings I I, and whose outline is similar to that of the rings C C. The lower edges of the latter are furnished with studs or projections at J.

The center or hub of the arms H H is formed into a sort of sleeve, which passes up into a corresponding opening in the lower part of the hub B'. Above the hub B' a heavy horizontal arm, L, is firmly keyed to the shaft F. This arm has projections upon its lower face, which, when in motion, run just free of the arms B B.

The shaft F, at its lower end, is supposed to have a bearing in a suitable step, which is so constructed that it can be raised or lowered, as may be desired, and by which the opposing faces of the annular rings C C and I I may be adjusted as to the distance between the same, thus providing for the character, as to size, of the material as it comes from the mill.

Operation: The step or bearing upon which the shaft F revolves being properly adjusted so as to bring the faces of the lower parts of the rings C C and I I in proper position, motion is imparted to the shaft F, which, in turn, revolves the arm L and the clutch G. The latter engages the lugs upon the under side of the arms H H, which carry the rings I I. The material to be ground is thrown, in coarsely-broken pieces, into the top of the shell A A, where it first comes in contact with the revolving arm L. The projections upon the under side catch the bark, and partly crush it as they pass the arms B B, from between which it drops between the rings C C and I I. The upper edges of the latter have some sharp projecting points, (not discernible in the drawings,) which further serve to break the material before it comes in contact with the opposing serrated surfaces of the annular rings. The latter, from their shape, gradually approximate each other in their vertical outline, until the point shown by the horizontal line *x* is reached, and from the abrasion of these surfaces and their serrations the bark or other material is more fully broken or ground as it descends.

In use it is found that the dust of the mill will impact itself quite firmly at the bases of the rings I I on the arms H H. The little studs J on the lower edges of the rings C C serve as cleaners for these spaces.

Having thus described my invention, and disclaiming the general construction of the body of the mill as not novel, what I do claim as new, and desire to secure by Letters Patent, is—

In a mill for the reduction and grinding of bark, the stationary annular grinding-rings C C, provided upon their lower edges with the clearing studs or projections J, in combination with the arms H H, carrying the runner-rings I I, as and for the purpose set forth.

CHAS. P. RYTHUR.

Witnesses:

GEO. W. MORROW,  
J. C. HOUSE.