



- (51) International Patent Classification:
B67D 3/00 (2006.01)
- (21) International Application Number:
PCT/US2010/039738
- (22) International Filing Date:
24 June 2010 (24.06.2010)
- (25) Filing Language: English
- (26) Publication Language: English
- (30) Priority Data:
BR PI0902553-7 19 August 2009 (19.08.2009) BR
- (71) Applicant (for all designated States except US): **ARCH CHEMICALS, INC.** [US/US]; 501 Merritt 7, P.O. Box 5204, Norwalk, CT 06856-5204 (US).
- (72) Inventors; and
- (75) Inventors/Applicants (for US only): **ATTIE, Jorge, Luiz** [BR/BR]; Av. Jorge Joao Saad, 1001, Morumbi, Sao Paulo, Sp (BR). **GASPAROTTO, Marcus, Vinicius** [BR/BR]; Rua Bom Pastor 2071 - Ap. 156, Ipiranga, Sao Paulo (BR).
- (74) Agent: **ANDERSON, Jay, H.**; Wiggin and Dana LLP, One Century Tower, New Haven, CT 06508-1832 (US).
- (81) Designated States (unless otherwise indicated, for every kind of national protection available): AE, AG, AL, AM, AO, AT, AU, AZ, BA, BB, BG, BH, BR, BW, BY, BZ, CA, CH, CL, CN, CO, CR, CU, CZ, DE, DK, DM, DO, DZ, EC, EE, EG, ES, FI, GB, GD, GE, GH, GM, GT, HN, HR, HU, ID, IL, IN, IS, JP, KE, KG, KM, KN, KP, KR, KZ, LA, LC, LK, LR, LS, LT, LU, LY, MA, MD, ME, MG, MK, MN, MW, MX, MY, MZ, NA, NG, NI, NO, NZ, OM, PE, PG, PH, PL, PT, RO, RS, RU, SC, SD, SE, SG, SK, SL, SM, ST, SV, SY, TH, TJ, TM, TN, TR, TT, TZ, UA, UG, US, UZ, VC, VN, ZA, ZM, ZW.
- (84) Designated States (unless otherwise indicated, for every kind of regional protection available): ARIPO (BW, GH, GM, KE, LR, LS, MW, MZ, NA, SD, SL, SZ, TZ, UG, ZM, ZW), Eurasian (AM, AZ, BY, KG, KZ, MD, RU, TJ, TM), European (AL, AT, BE, BG, CH, CY, CZ, DE, DK, EE, ES, FI, FR, GB, GR, HR, HU, IE, IS, IT, LT, LU, LV, MC, MK, MT, NL, NO, PL, PT, RO, SE, SI, SK, SM, TR), OAPI (BF, BJ, CF, CG, CI, CM, GA, GN, GQ, GW, ML, MR, NE, SN, TD, TG).

[Continued on next page]

(54) Title: DISPENSING CAP FOR A CONTAINER

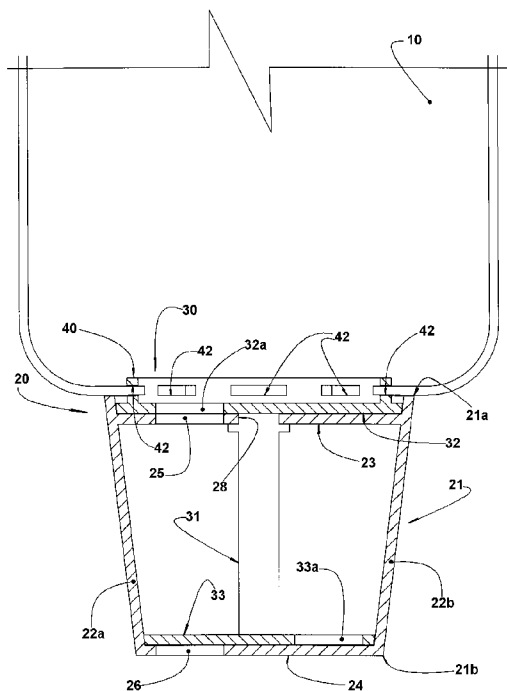

FIG. 4

(57) Abstract: A cap (20) is attached to a container (10) by means of a device (30) with first and second disks (32,33) mounted on opposite ends of a shaft (31), each disk having an opening (32a, 33a). A cover cup (21) is rotatably mounted on the shaft (31) of the device (30) and presents an interior wall (23), transversal and provided with an opening (25), and an end wall (24) with an opening (26), so that, with the container (10) being inverted, rotation of the cover cup (21) to a first position provokes alignment of the opening (25) of the interior wall (23) of the cover cup (21) with the opening (32a) of the first disk (32), permitting material to flow from the container (10) to the interior of the cover cup (21), and a subsequent rotation of the cover cup (21) to a second position aligns the opening of the second disk (33) with the opening (26) of the end wall (24) of the cover cup (21), to permit dispensing the material from the cover cup (21) to a place of use.

WO 2011/022118 A1

Published:

— *with international search report (Art. 21(3))*

DISPENSING CAP FOR A CONTAINER

Field of the Invention

The present invention relates to a cap for dispensing a
5 measured amount of material from a container, without having
to remove the cap from the container.

Background of the Invention

Many materials are provided to users in a large volume
10 contained in containers and the user is compelled to
dispense a certain amount of the material from the
container. As a typical example of said situation, it can be
cited a liquid, such as a detergent for washing a load of
clothes in a washing machine or for washing a load of dishes
15 in a dishwasher, which liquid is presented to the users in a
container that holds a substantial volume of the liquid.
The user is thus compelled to dispense a certain reasonably
precise amount of said liquid from the container to wash a
load of clothes or dishes. Dispensing of the liquid from the
20 container can be accomplished in various ways.

In one way, the user can first unscrew the container
sealing cap and pour the liquid from the container into a
measuring cup or spoon to obtain the desired amount. The
liquid is then transferred from the cup or spoon to the
25 clothes washing machine or dishwasher. The user then screws
the cap back onto the container.

In another way, the sealing cap itself serves as a
measuring instrument by being constructed to hold the
desired amount of liquid. In this case, the user unscrews
30 the cap from the container, dispenses the liquid into the
cap, transfers the liquid from the cap to the machine and,
finally, screws the cap back onto the container.

While the ways of transferring material from the
container into the washing machine or other place of use for
35 the material are reasonably easy to accomplish, they can
give rise to several annoyances. For example, the user might
over fill the measuring cup or spoon or even the cap itself

when it serves as the measuring instrument. This not only causes a waste of material, but the user will have to clean up the over fill amount. Also, material can be unduly spilled as it is being transferred from the measuring cup or spoon or from the adequately dimensioned cap to the place of use. Further, there is always the risk that a container with the cap removed accidentally will be pushed off from its resting position, allowing the material to be spilled out from the container. This wastes the material and also presents a disagreeable clean up problem.

Accordingly, a need exists for an arrangement by which a measured amount of material in a container can be transferred directly from the container to a place of use, such as a dishwasher or clothes washing machine, without having to remove the cap from the container.

Summary of the Invention

A container cap is provided that is capable of transferring material directly from the container to the place of use, without having to remove the container cap.

The present cap has two main components. The first component is an outer cover cup in the form of a conventional cap. The cover cup has a distal, or top, end wall and a proximal wall across the interior of the cover cup, disposed in the interior of the cap and adjacent to the end wall close to the proximal end of the cover cup. The terms "proximal" and "distal" define relative positions in relation to the top opening of the container to which the cap is applied. A pair of aligned openings is formed, each opening being formed in one of the proximal and distal walls of the cover cup.

The cover cup is rotatably mounted on the second cap component, which is a dual function device that fixedly holds the cap to the container and also controls dispensing or pouring of the material from the container to the place of use, as the cover cup is rotated to various positions relative to the dual function device that is fixedly mounted

to the container. The dual function device has a disk at each end of a shaft and the cover cup is rotatably mounted to the shaft, with one disk being adjacent to each of the distal and proximal walls of the cover cup. An annular rim extends from the proximal disk of the dual function device and is located externally to the cap and presents slots that are used to fasten the cap to the container. Each of the device disks has an opening, with the openings of the two disks being angularly offset from each other relative to the shaft axis of the device.

Upon operation of the cap, the container to which it is fixed is inverted, with the distal end wall of the cover cup turned downwardly and preferably located over the place of use, where material from the container is to be dispensed. At this time, the cover cup is in its closed position, none of the openings of the cover cup and of the device disks being aligned. Therefore, the container opening is sealed and no material can be released therefrom. The cover cup is then rotated with respect to the device disks, to first and second operating positions, in order to bring different openings of the cover cup and disks into and out of alignment. Dispensing of material from the container into the interior of the cover cup is controlled by rotating the cover cup to its first operating position to align the opening in the proximal inner wall of the cover cup with the opening of the proximal disk. With the container being inverted, this permits material from the container to flow into the interior of the cover cup. The cover cup is then rotated to a second operating position which aligns the openings of the distal end wall of the cover cup with the opening of the disk at the distal end of the device shaft. This permits the material within the cover cup to be dispensed from the interior of the cap to the ambient, that is, to the place of use.

It should be noted that the cap operates so that only the material admitted in the interior of the cover cup is dispensed to the place of use. Accordingly, the material is

dispensed from the container in a controlled fashion. The maximum amount of material dispensed in one operation is determined by the fillable volume in the cover cup of the cap. Moving the cover cup more quickly between its closed
5 position and the first operating position can fill the cover cup with less than a full volume, so that lesser amounts of the material can be taken from the container and dispensed to the place of use. The present cap solves the problems of
10 overflow of the measuring instrument and material spilling from the container if it is inadvertently displaced from its resting position.

Brief Description of the Drawings

Other objects and advantages of the present invention
15 will become more apparent, upon reference to the following description and annexed drawings, in which:

Figure 1 is a lateral elevation view of the device with a cap attached thereon;

Figure 2 is an exploded perspective view of the cap
20 showing its components;

Figure 3 is an overall perspective view of the cap; and

Figure 4 is a partial cross section view of the container and of the device which maintains the cap fixedly retained to the container, the cover cup being in its first
25 operational position, in which the material is allowed to flow gravitationally from the interior of the container to the interior of the cap.

Detailed Description

30 Figure 1 shows a container 10 for holding a quantity of a material. The material typically is a liquid, such as a detergent to be used in a clothes washing machine or dishwasher. The material may also be a solid material, such as a powder, beads, flakes, granules, etc.

35 The container 10 is made of plastic material and can be made by any conventional process, such as blow molding. It has a handle 11 which defines an opening 12 into which the user's

hand fits as he grasps the handle. The handle 11 preferably is round and disposed close to the bottom of the container, so as to make it easier the gripping by the user. The open top end of the container is closed by a cap 20 that has a cover cap 21 that is accessible to the user. The cover cup 21 is generally frusto-conical in shape. It tapers from a wider proximal end 21a, which is attached to the container to seal its opening, to a distal end 21b of lesser diameter.

The cap 20 has the cover cup 21 as shown in Figure 3. For purposes of assembly of the cap, whose details are shown in Figure 2, the cover cup 21 is formed in two sections, preferably in the form of half sections 22a and 22b. The cover cup sections 22a and 22b are preferably of a suitable plastic material and are joined together by any suitable process, for example, heat sealing or gluing. A wall part 23a and 23b, each being of a generally semi-circular shape, is provided in each cover cup section 22a, 22b near the proximal end 21a of the cover cup 21. The terms "proximal" and "distal" are used in describing orientation of the cap relative to the container, these terms being preferable to "upper" and "lower", since the cap is generally provided at the upper end of the container, but the container is held upside down during the dispensing operation of the material.

Similarly, a respective semi-circular wall part 24a and 24b is provided at the distal end 21b of the cover cup 21. When the two cover cup sections 22a and 22b are joined together, there will be formed a full proximal wall 23 across the interior of the cover cup 21 and a full distal wall 24 which will form the distal end 21b of the cap 20.

Each of the proximal wall parts 23a and 23b of the cover cup sections 22a and 22b has a semi-circular opening or cutout 28 at the center of the elongated edge of the wall part. When the two sections 22a, 22b of the cover cup 21 are joined together, the openings 28 form a circular wall that will be fitted around a shaft, in a manner to allow the cover cup 21 to rotate about the shaft. A respective opening 25 and 26 is formed in the proximal and distal walls 23 and

24 of the cover cup 21. The openings 25 and 26 are vertically aligned (see Figure 4).

The cap 20 also has a dual function device 30 having a part that fixedly attaches the cap 20 to the container 10 and parts that cooperate with the openings 25, 26 in the proximal and distal walls 23, 24 of the cover cup 21, to control the dispensing of material from the container 10 to the interior of the cover cup 21 and then to the place of use, upon rotation of the cover cup 21. The dual function device 30 is also preferably made of molded plastic material and presents a central shaft 31, around which the openings (semi-circular cutouts) 28 of the proximal wall sections 23a and 23b of the cover cup 21 are fitted. A first circular disk 32 is mounted on the proximal end of shaft 31 (relative to the cap 20 being fastened to the container 10) and a second circular disk 33 is mounted on the distal end of the shaft 31.

A respective opening 32a and 33a is provided in the disks 32 and 33 of the device 30. Each of the openings 32a and 33a is offset from the center of its disk. The openings 32a and 33a are also angularly offset from each other by about 180° relative to the shaft 31, but it should be understood that any other suitable angle can be selected. Material from the interior of the container may be dispensed into the interior of cover cup 21 when it is rotated about the shaft 31 of the device 30, to a position in which the opening 25 of the proximal wall 23 of the cover cup 21 is aligned with the opening 32a of the proximal disk 32. This alignment is shown in Figure 3. The material loaded into the interior of the cover cup 21 is dispensed to the exterior place of use when the cover cup 21 is rotated to align the distal end opening 26 of the cover cup 21 with the opening 33a of the disc 33.

An annular rim 40 is formed around the circumference of the proximal disk 32 of the device 30 and extends outwardly of the cover cup 21. The rim 40 has a plurality of slots 42 around its circumference. In an embodiment, as shown in

figures 2 and 3, the slots 42 fit on tabs (not shown) incorporated in a single piece with the container 10, along the opening thereof, to fixedly fasten the cap 20 to the container 10. In this embodiment, the fastening can be
5 permanent, such as by heat sealing or gluing the container tabs to the annular rim 40. Alternatively, the slots 42 and tabs may be configured as a "bayonet" fastening arrangement, to permit the cap 20 to be manually rotated and separated from the container **10**.

10 The components of the cap 20 are assembled by bringing the two sections 22a and 22b of the cover cup 21 together, so that the proximal disk 32 of the device 30 rests on the proximal wall 23 of the cover cup 21 and the distal disk 33 of the device 30 rests on the distal wall 24 of the cover
15 cup 21. The walls of the cover cup 21 and the disks are preferably engaged to each other to minimize leakage of the material. The semi-circular openings 28 of the wall parts 23a and 23b of the cover cup 21 fit around the shaft 31 of the device 30 and are large enough to permit the cover cup
20 21 to rotate about the shaft 31. The sections 22a and 22b of the cover cup 21 are moved toward each other until their edges engage and the engaging surfaces are joined together by heat sealing or an adhesive, to complete assembly of the cap 20. The edges of the sections 22a and 22b of the cover
25 cup 21 and those of the proximal and distal wall parts 23a, 23b and 24a, 24b may have ridges and grooves which snap the sections together, providing a better foundation for joining said sections together.

30 In the use of the dispensing cap of the invention, the fully assembled cap 20 is attached to the open end of the container 10 by inter-fitting of the slots 42 of the annular rim 40 on the proximal disk 32 of the device 30 with the tabs (not shown) provided along the opening of the container 10. The container 10, with its cap already attached, is
35 inverted with the distal end 21b of the cover cup 21 disposed downwardly and preferably located over the place of use, in which the material from the container 10 is to be

dispensed. At this time, the cap 20 is closed, by first rotating the cover cup 21 to a position in which neither of the openings 25 and 26 of the cover cup 21 is aligned with a corresponding opening 32a and 33a of the disks 32 and 33 of the device 30. That is, the opening of the container 10 is sealed and no material can leave it. The user rotates the cover cup 21 to first and second material dispensing operating positions relative to the disks 32, 33 of the device 30 which are fixed relative to the container 10. This brings the different openings of the walls of the cover cup 21 and of the disks of the device 30 into and out of a mutual alignment.

Dispensing or releasing of material from the container 10 into the interior of the cover cup 21 is controlled by rotating the cover cup 21 to its first material dispensing operating position. This aligns the opening 25 of the proximal wall 23a of the cover cup 21 with the opening 32a of the proximal disk 32 of the device 30 (see figures 3 and 4). With the container 10 being inverted, the material is allowed to exit from the container 10 and flow into the interior of the cover cup 21. The cover cup 21 is then rotated to a second material dispensing position, in which the openings 25 and 32a are moved out of alignment, so that no material from the container can enter the cover cup 21. This movement also aligns the opening 26 of the cover cup 21 with the opening 33a of the disk 33 of the device 30. This permits the material within the cover cup 21 to leave the latter and flow into the interior of the desired place of use. The user then moves the container to its upright position (not inverted) and preferably rotates the cover cup 21 to a closed position, so that no material can be dispensed. To facilitate the user rotating the cover cup 21 to the desired positions, there may be visual markings provided on the cover cup 21 and on the annular rim 40. There also may be provided a detent type arrangement provided with depressions and projections on the mating

surfaces of one pair of mutually engaging walls of the cover cup 21 and of the disk 32.

It should be noted that the cap operates so that only the material of the cover cup 21 is emptied to the place of use. Accordingly, the material is dispensed from the container 10 in a controlled fashion. The maximum amount of material dispensed in one operation is determined by the fillable volume of the cover cup 21. This is determined by the overall dimensioning of the cover cup 21 and by the spacing between the disks of the dual function device 30. Moving the cover cup 21 quickly between its closed position and the first material dispensing position can fill the cover cup 21 with less material than that corresponding to its full volume, so that lesser amounts of material can be taken from the container 10 and dispensed in the place of use.

While the cap has been described as having the cover cup openings axially aligned and the disk openings angularly offset, the reverse arrangement can be used. Also, while the openings 32a, 33a and 25, 26 are illustratively shown as being circular, they can be of any desired shape, such as, for example, having an elliptical contour.

Specific features of the invention are shown in one or more of the drawings for convenience only, as each feature may be combined with other features. Alternative embodiments, including obvious changes and various modifications, will be recognized by those skilled in the art and are intended to be included within the scope of the claims. Accordingly, the above description should be construed as illustrating and not limiting the scope of the claims that accompany the present specification.

CLAIMS

1. A dispensing cap for a container, characterized in that it comprises a dispensing control device (30) mounted over
5 an opening of the container (10); and a cover cup (21) mounted on said device (30) which has a first pair of openings (32a, 33a), said cover cup (21) having a second pair of openings (25, 26), with the openings of each of said first and second pairs being spaced apart along the height
10 of said cover cup (21); with the container (10) being inverted relative to its opening, the rotation of the cover cup (21) to a first position aligns the first openings of said first and second pairs of openings (32a, 33a; 25, 26), to permit dispensing of material from the container into the
15 cover cup (21), and the rotation of the cover cup (21) to a second position moves said first openings of said first and second pairs of openings (32a, 33a; 25, 26) out of alignment and aligns the second openings of said pairs of openings, to permit dispensing of the material from the interior of the
20 cover cup (21).

2. The cap as claimed in claim 1, characterized in that said device (30) comprises: a shaft (31); and a disk (32, 33) mounted at each end of said shaft (31), each disk (32, 33)
25 having formed therein one opening of said first pair of openings (32a, 33a).

3. The cap as claimed in claim 2, characterized in that said cover cup (21) has an end wall (24) and further comprises a
30 wall (23) across the interior of the cover cup (21), each of said end wall (24) and interior wall (23) of said cover cup (21) having formed therein one of the openings of said second pair of openings (25, 26).

35 4. The cap, as claimed in claim 3, characterized in that said interior wall (23) of the cover cup (21) has a central hole (28) which fits around the shaft (31) of said device

(30) to rotatably mount said cover cup (21) to said device (30).

5 5. The cap as claimed in claim 3, characterized in that the openings (25, 26) of one of said first and second pairs of openings (32a,33a; 25,26) are vertically aligned and the openings (32a,33a) of the other pair of openings are angularly offset from each other relative to a vertical axis.

10

6. The cap as claimed in claim 4, characterized in that it further comprises an annular rim (40) on said disk (32) that projects outwardly of the end of the cover cup (21) opposite said end wall (24) of the cover cup (21), to attach said device (30) to the container (10).

15

7. The cap, as claimed in claim 6, characterized in that said annular rim (40) surrounds the opening of the container (10).

20

8. The cap, as claimed in claim 6, characterized in that said disk (32) having said annular rim (40) overlies the surface of the interior wall (23) of the cover cup (21) that is most remote from said end wall (24) of the cover cup (21).

25

9. The cap as claimed in claim 5, characterized in that a surface of each said end wall (24) and interior wall (23) of said cover cup (21) engages a surface of one of said disks (32,33) as said cover cup (21) is rotated.

30

10. A dispensing cap for a container to dispense a measured amount of material from the container to a place of use, characterized in that it comprises:

35

a device (30) mounted to the container (10) and including a shaft (31) and having first and second disks (32,33) mounted on opposite ends of the shaft (31) and an

opening (32a,33a) in each disk that is angularly offset from the opening of the other disk relative to the axis of the shaft (31); and

5 an outer cover cup (21) mounted for rotation about said shaft (31), said cover cup (21) having a first wall (23), across the interior of said cover cup (21), having a first opening (25) and an end wall (24) with a second opening (26), the rotation of the cover cup (21) to a first position aligning the first opening (25) with the opening (32a) in
10 the first disk (32), opening the container (10) to the interior of the cover cup (21), while closing the cover cup (21) to the ambient, and the rotation of the cover cup (21) to a second position aligning the opening (33a) of the second disk (33) with the opening (26) of the end wall (24),
15 closing the container (10) to the interior of the cover cup (21) and opening the cover cup (21) to the ambient.

11. The cap as claimed in claim 10, characterized in that it further comprises an annular rim (40) extending from said
20 first disk (32) to attach said cap (20) to the container (10) at the opening of the latter.

12. The cap as claimed in claim 10, characterized in that a surface of the first wall (23) of the cover cup (21) engages
25 a surface of said first disk (32) and an inner surface of said end wall (24) of the cover cup (21) engages a surface of said second disk (33) as said cover cup (21) is rotated.

1/4

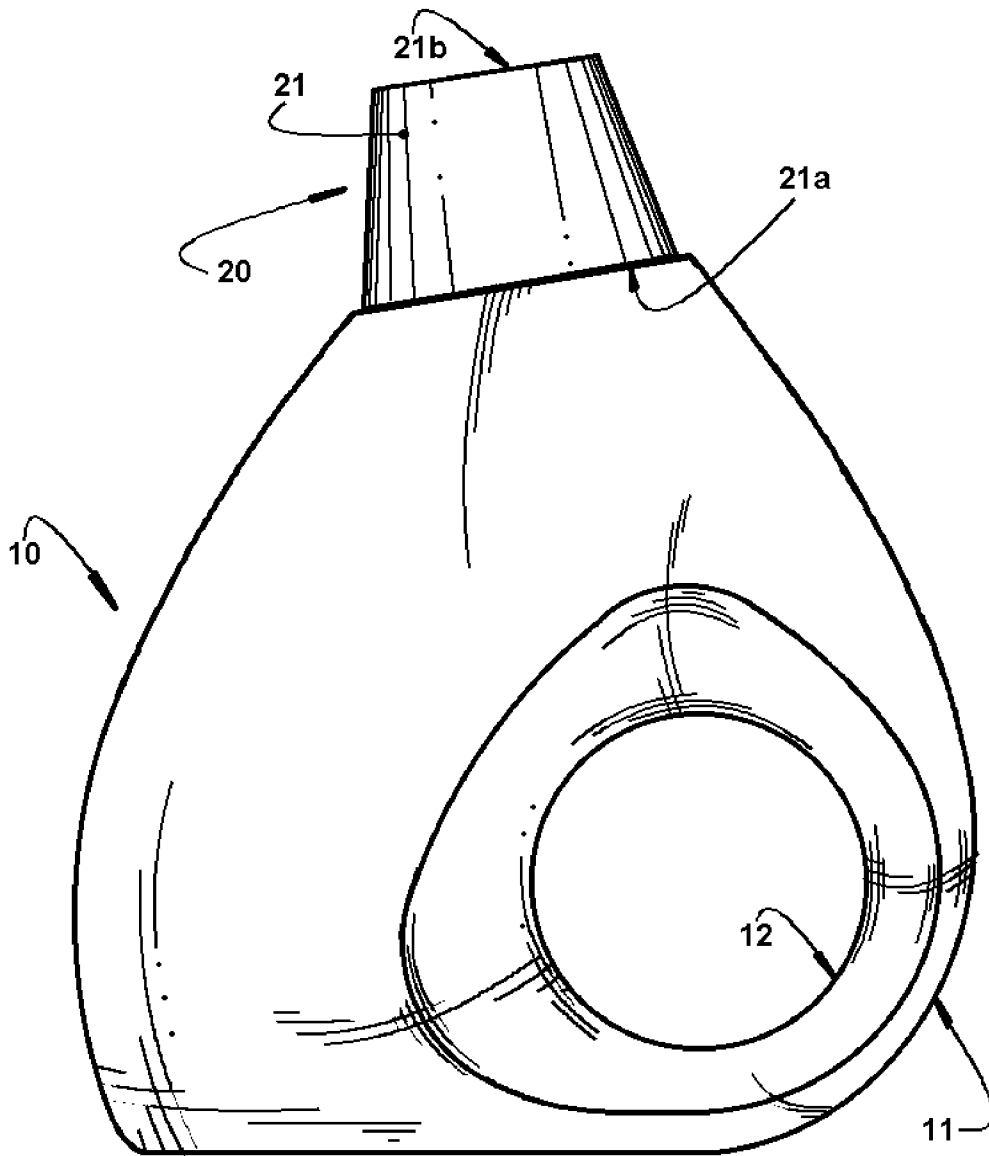

FIG. 1

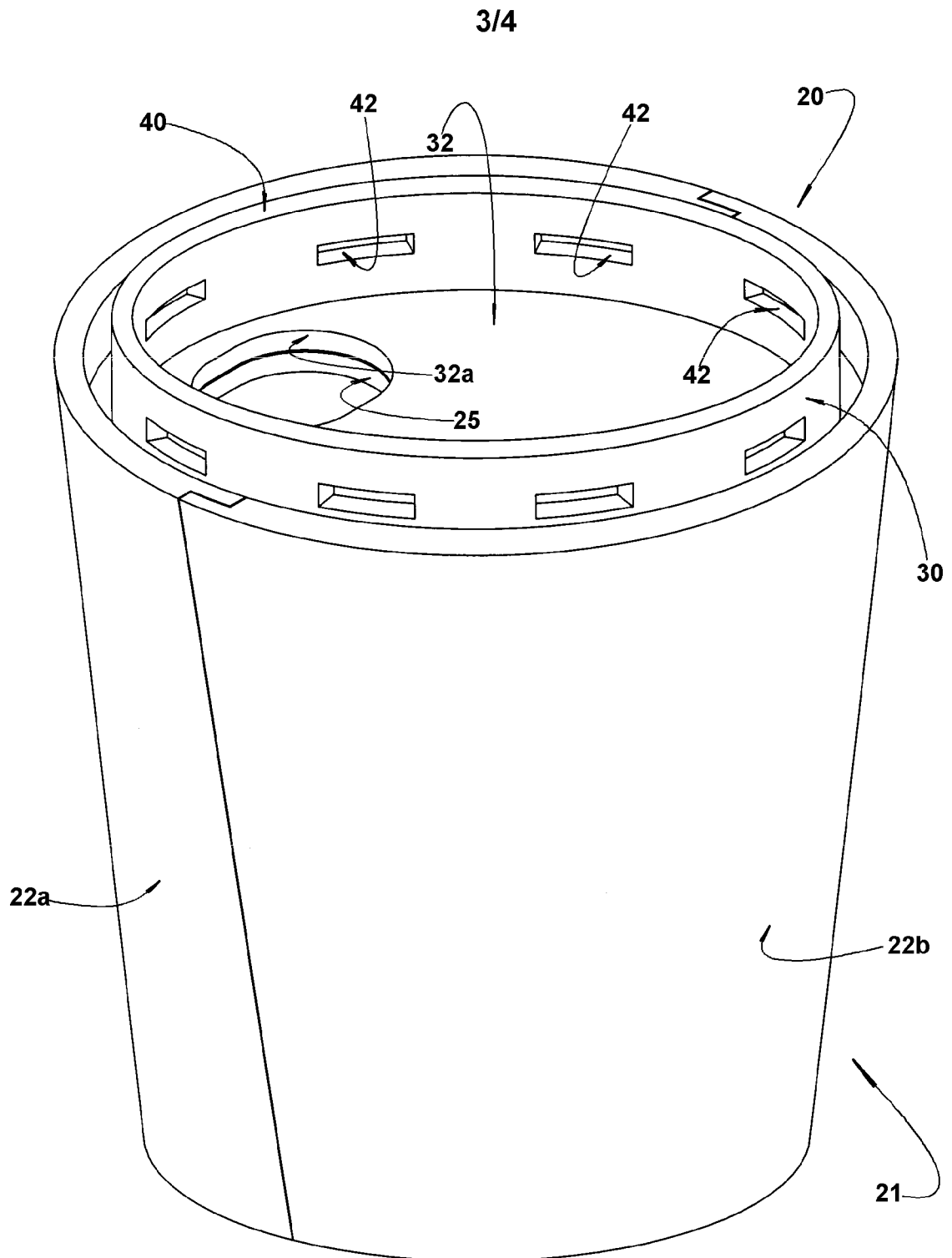

FIG. 3

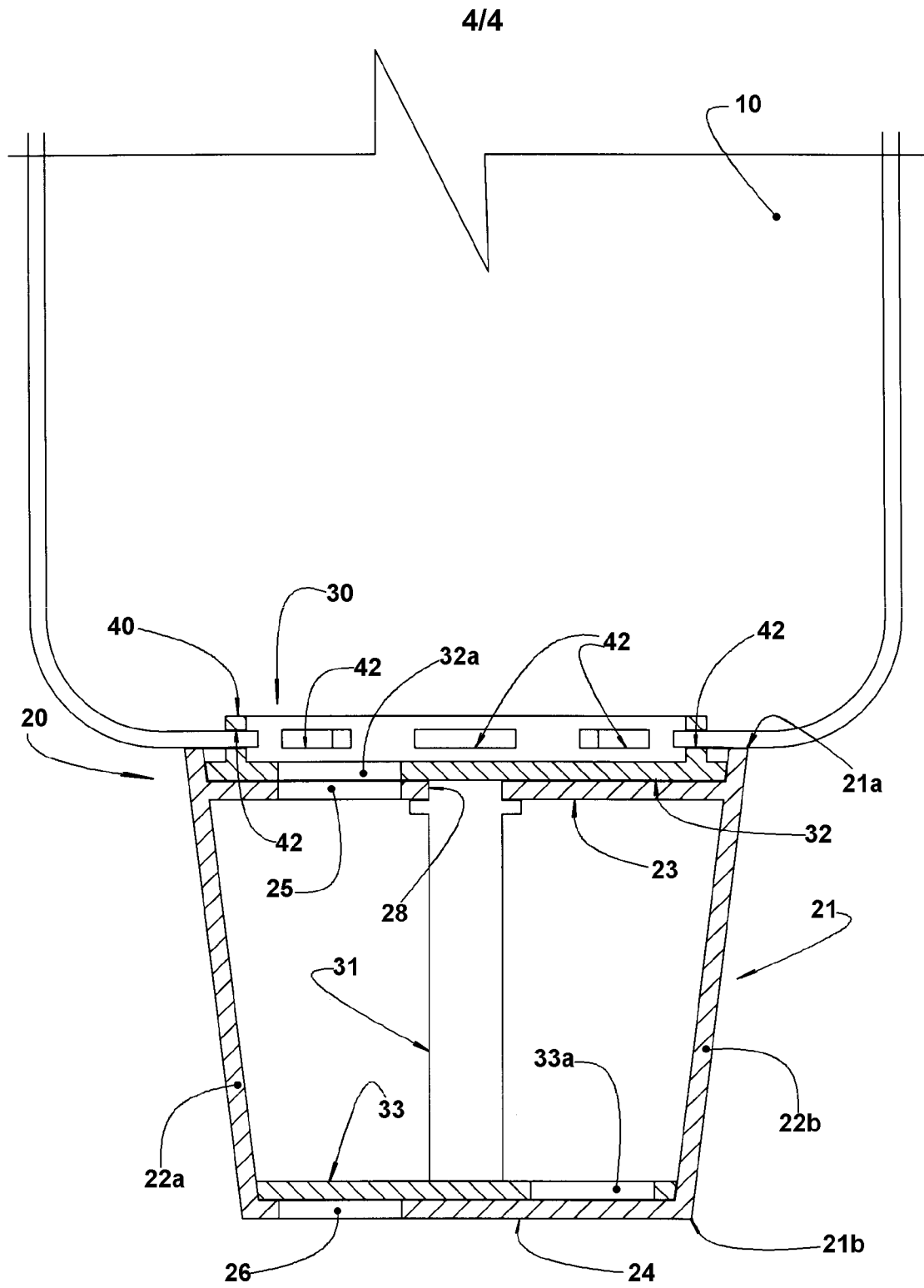

FIG. 4

INTERNATIONAL SEARCH REPORT

International application No.

PCT/US2010/039738

A. CLASSIFICATION OF SUBJECT MATTER

IPC(8) - B67D 3/00 (2010.01)

USPC - 222/483

According to International Patent Classification (IPC) or to both national classification and IPC

B. FIELDS SEARCHED

Minimum documentation searched (classification system followed by classification symbols)

IPC(8) - B67D 3/00 (2010.01)

USPC - 222/478, 481, 482, 483, 484, 526, 531-533, 536, 537, 544, 566

Documentation searched other than minimum documentation to the extent that such documents are included in the fields searched

Electronic data base consulted during the international search (name of data base and, where practicable, search terms used)

PatBase, Google Patents

C. DOCUMENTS CONSIDERED TO BE RELEVANT

Category*	Citation of document, with indication, where appropriate, of the relevant passages	Relevant to claim No.
X -- Y	US 6,283,339 B1 (MORROW) 04 September 2001 (04.09.2001) entire document	1, 10-12 ----- 2-9
Y	US 928,052 A (HIRSCH) 13 July 1909 (13.07.1909) entire document	2-9
A	US 5,044,527 A (HICKERSON) 03 September 1991 (03.09.1991) entire document	1-12
A	US 3,327,905 A (GOULD) 27 June 1967 (27.06.1967) entire document	1-12
A	US 4,345,700 A (SOUZA) 24 August 1982 (24.08.1982) entire document	1-12
A	US 2,898,010 A (TEPPER) 04 August 1959 (04.08.1959) entire document	1-12

 Further documents are listed in the continuation of Box C.

* Special categories of cited documents:

"A" document defining the general state of the art which is not considered to be of particular relevance

"E" earlier application or patent but published on or after the international filing date

"L" document which may throw doubts on priority claim(s) or which is cited to establish the publication date of another citation or other special reason (as specified)

"O" document referring to an oral disclosure, use, exhibition or other means

"P" document published prior to the international filing date but later than the priority date claimed

"T" later document published after the international filing date or priority date and not in conflict with the application but cited to understand the principle or theory underlying the invention

"X" document of particular relevance; the claimed invention cannot be considered novel or cannot be considered to involve an inventive step when the document is taken alone

"Y" document of particular relevance; the claimed invention cannot be considered to involve an inventive step when the document is combined with one or more other such documents, such combination being obvious to a person skilled in the art

"&" document member of the same patent family

Date of the actual completion of the international search

11 August 2010

Date of mailing of the international search report

30 AUG 2010

Name and mailing address of the ISA/US

Mail Stop PCT, Attn: ISA/US, Commissioner for Patents

P.O. Box 1450, Alexandria, Virginia 22313-1450

Facsimile No. 571-273-3201

Authorized officer:

Blaine R. Copenheaver

PCT Helpdesk: 571-272-4300

PCT OSP: 571-272-7774