

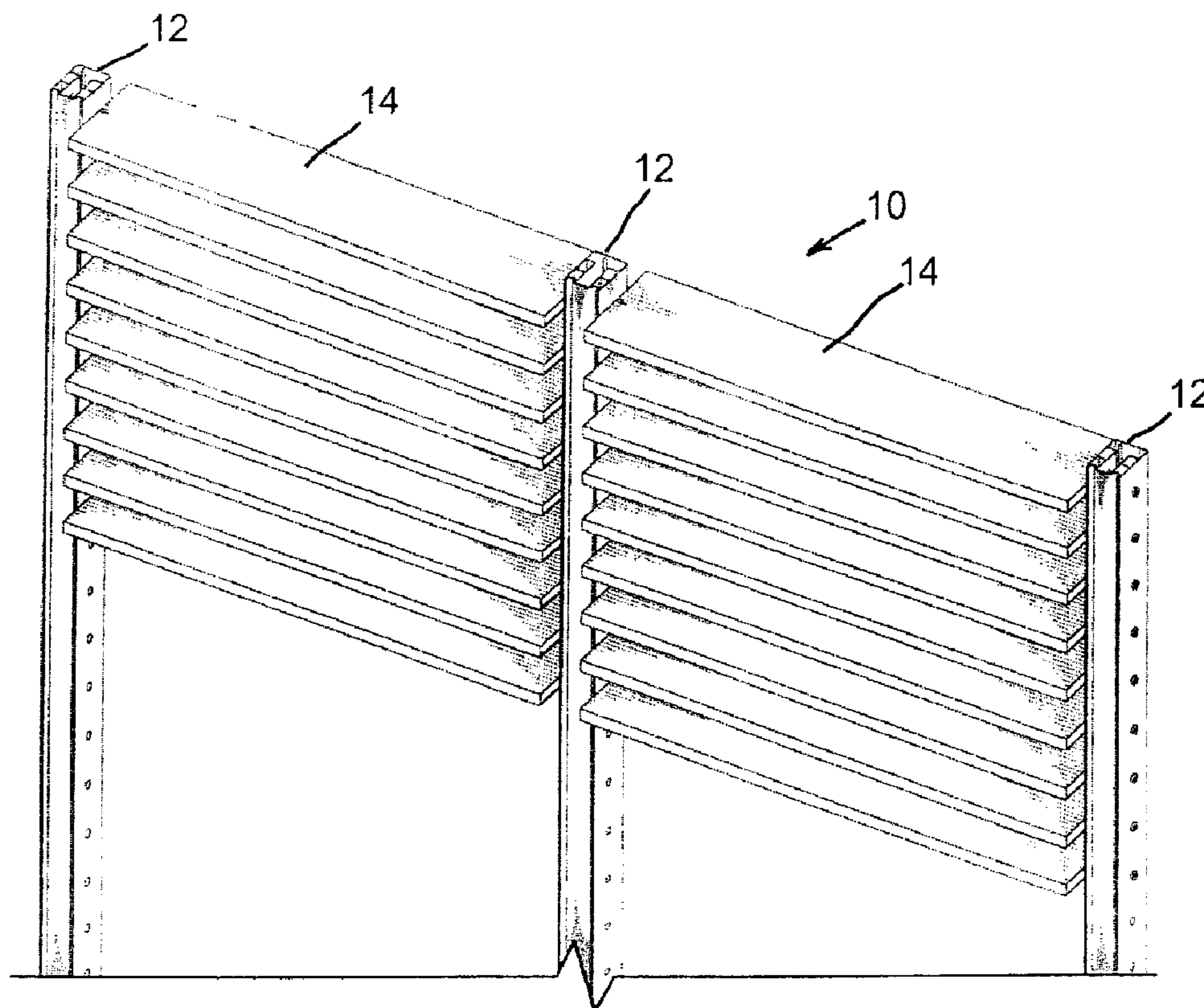

(22) Date de dépôt/Filing Date: 2011/03/08  
 (41) Mise à la disp. pub./Open to Public Insp.: 2012/02/18  
 (45) Date de délivrance/Issue Date: 2014/08/05  
 (30) Priorité/Priority: 2010/08/18 (US12/805738)

(51) Cl.Int./Int.Cl. *E06B 7/084* (2006.01)  
 (72) Inventeur/Inventor:  
 MAROCCO, MARIO M., CA  
 (73) Propriétaire/Owner:  
 MAXXMAR INC., CA  
 (74) Agent: ROLSTON, GEORGE A.

(54) Titre : **VOLET A PERSIENNES AMOVIBLES**  
 (54) Title: **SHUTTER WITH REMOVABLE LOUVRES**



(57) **Abrégé/Abstract:**

A shutter having a frame, and louvres and having a control mechanism for operating all louvres , louvre drive couplings in each louvre, at least one moveable drive connector member for connecting between each louvre drive coupling , the drive connector member being moveable between engaged and disengaged positions, and having biasing springs for the drive connectors , yieldable to permit movement of the drive connectors out of the engaged positions.



1296C110

**ABSTRACT OF THE DISCLOSURE**

A shutter having a frame, and louvres and having a control mechanism for operating all louvres , louvre drive couplings in each louvre, at least one moveable drive connector member for connecting between each louvre drive coupling , the drive connector member being moveable between engaged and disengaged positions, and having  
10 biasing springs for the drive connectors , yieldable to permit movement of the drive connectors out of the engaged positions.

1296C110

**FIELD OF THE INVENTION**

The invention relates to shutters of the type having a frame, and louvres rotatable in the frame, and a control system connected to the louvres, for rotating them open and closed, and having louvres which are individually removable from the frame for servicing.

**BACKGROUND OF THE INVENTION**

Shutters for windows and doors usually have a frame, mounted in the window or door opening, and rotatable louvres extending across the frame, from side to side. A control system is connected to the louvres. Moving the control system rotates all the louvres.

10 In this way the louvres can be tilted open for light and air, or tilted up or down and closed for privacy.

Shutters have been made in this general pattern for hundreds of years.

Where it is required to provide shutters for large, or high windows, or for example in institutions, or commercial or public buildings, or auditoriums and the like, additional features should preferably be provided.

The control system will preferably be concealed within the side of the frame.

The control system may be power operated, possibly with automatic sensors responding to sunshine, or changes in weather, time of day, internal temperature and the like.

20 The individual louvres should be capable of being removed and replaced, for servicing, or cleaning, without requiring major dismantling of the shutter.

This removable feature can be a problem. Each louvre is usually provided with axles or

1296C110

pivots at each end, by which it is mounted in the frame. The control system connects with each louvre, usually through one of the axles, so that operation of the control system will rotate all louvres in unison.

To render the louvres individually removable, the connection between the control system and each louvre is releasable. The louvres themselves are removable individually from the frame so that they can be dismantled and taken away for cleaning or replacement, without disturbing the frame itself or the rest of the louvre.

### **BRIEF SUMMARY OF THE INVENTION.**

In order to achieve at least some of these features , the invention provides a shutter of  
10 the type having a frame, and louvres extending from side to side within the frame, the  
louvres being rotatable about parallel axes and there being louvre axles for each end  
of each louvre, and comprising; a control mechanism within at least one side of the  
frame for operating all louvres ; control drive members in said control mechanism for  
engaging respective said louvres ; louvre drive couplings in each said louvre for  
coupling a louvre to its respective said control drive member ; at least one moveable  
drive connector for connecting between at least one of said control drive members and  
at least one of said louvre drive couplings for each said louvre, said moveable drive  
connector being moveable between engaged and disengaged positions to release said  
louvre from said control drive member ; respective biasing devices urging respective  
20 said drive connectors into said engaged positions and said biasing device being  
yieldable to permit movement of said drive connectors out of said engaged positions.  
Preferably there are respective drive socket members in respective said control drive

1296C110

members , and drive connector devices being slidable within said socket relative to respective said louvre drive couplings. A control button on said connector and a slot opening in said coupling.

Preferably the drive socket members have drive surfaces, and said drive connectors have complementary drive faces.

Preferably a locking member is engageable with said drive connector, operable to hold said drive connector in its disengaged position.

Preferably said drive sockets in said control drive couplings are of generally non circular interior shape, and said louvre drive couplings comprise elongated sockets of  
10 rectangular interior shape mounted in respective said louvres .

Preferably said control mechanism includes respective louvre drive members for respective said louvres , each of said louvre drive members having a rotatable body portion, and at least one lever arm extending outwardly from said body portion operable to rotate said body portion.

Preferably there is control linkage extending between respective said lever arms operable to cause operation of all said lever arms and said body portions simultaneously.

Preferably the control mechanism includes a form of safety clutch, to avoid damage in the event of errors in operation.

20 According to a further embodiment it is possible to employ the same design for releasing individual louvres, while avoiding the formation of slotted openings in the louvres themselves.

1296C110

The various features of novelty which characterize the invention are pointed out with more particularity in the claims annexed to and forming a part of this disclosure. For a better understanding of the invention, its operating advantages and specific objects attained by its use, reference should be made to the accompanying drawings and descriptive matter in which there are illustrated and described preferred embodiments of the invention.

### **IN THE DRAWINGS**

Figure 1 is a perspective on a portion of a shutter illustrating the invention;

Figure 2 is a perspective illustration showing a drive coupling member, coupled with two  
10 louvres, and showing a control mechanism , partly in phantom;

Figure 3 is a perspective illustration showing the shutter frame and control mechanism partly in phantom and a drive coupling member, within the frame but without louvres coupled thereto;

Figure 4 is an exploded perspective illustration showing a drive coupling member, and a drive coupling and a portion of a louvre;

Figure 5 is an exploded perspective illustration corresponding to Fig 4 but showing the coupling member separated from the drive coupling;

Figure 6 is an exploded perspective of another embodiment ;and

Figure 7 is a section along 7-7 of Fig 6.

### **DESCRIPTION OF A SPECIFIC EMBODIMENT**

Referring to Figure 1 it will be seen that this illustrates an embodiment of the invention,

1296C110

in the form of a shutter (10 ) having a frame with side members (12 ) . The frame will also have top and bottom members (not shown) in most cases .

Louvres (14 ) extend from side to side of the frame, at spaced intervals. As is well known such louvres (14 ) are rotatable between open and closed positions.

In simple domestic shutters the louvres are permanently installed in their frames.

Cleaning or servicing of such simpler shutters does not present any major problem.

However, in the case of larger shutter installations, such as in public spaces,

institutions, commercial space and the like, the shutters are usually larger and may

extend up to a height of two or three stories high. The windows may be wider than in

10 domestic situations, requiring shutters with longer louvres than usual. As a result the

entire shutter system must be made heavier, and stronger, than is usual for domestic

shutters. The louvres (14 ) are preferably power operated, possibly controlled by some

form of automatic sensor. Cleaning and servicing , and of course installation of such

shutters becomes a more arduous task. In order to make this work easier the

louvres (14 ) are made so that they are individually removeable, and replaceable .

As is best shown in Figs 2, 3, 4 and 5 the shutter (10 ) has side frames (12 ) which are

four sided hollow metal channels, in this case. Top and bottom frames (not shown)

would normally be provided, and made from the same channel.

Louvres (14 ) are supported between the two side frames (12 )

20 Within the hollow side frames (12 ) there are located a plurality of control drive

members (16 ) . The control drive members (16 ) are supported in suitable bearing

openings in the hollow side frames (12 ) .

1296C110

The control drive members comprise generally a single , or a pair of sleeves (18) , (which in this case are of generally cylindrical shape), and two drive levers (20) , extending outwardly on opposite sides , normal to the axis of the control drive members (16) .

The drive levers (20) have drive pins (22) . Control operating rods (24) extend lengthwise up the hollow side frames and connect with each of the drive pins (22) , on respective drive levers (20) . There are two such control drive members (24) , one for one of the drive levers (20) on each control drive member (16) and the other for the other drive levers (20) of each such control drive member (16) .

- 10 Movement of one control operating rods (24) upwards, will be matched by corresponding movement of the other of the control operating rods (24) downwards . In this way a smooth positive rotation of each of the control drive members (16) is assured.

A power drive mechanism (not shown) may be provided which connects with the control operating rods. Alternatively operation of the control operating rods may be a manual system, by any suitable means (not shown). Operation of the control operating rods, in opposite directions, as described above, will cause rotation of control drive members (16)

- 20 It will be appreciated that within the cylindrical sleeves (18) there are formed generally rectangular shaped drive socket member (26) . Preferably these are formed of moulded plastic for simplicity, held within the cylindrical sleeves (18)

The louvres (14) are provided with louvre drive couplings (28) which are essentially

1296C110

rectangular shaped sockets , held in the ends of the louvres (14) .

Respective drive connector members (30) of complimentary, non circular cross section, and defined by a rectangular shaped bar, are located within each of said louvre drive couplings (28) .

The drive connector member (30) makes a snug sliding fit in both the drive socket members (26) and in the louvre drive couplings (28) . In this way the drive connector members (30) communicate the rotational drive from the control drive members (16) to each of louvres (14).

10 In order to permit removal and replacement of the louvres (14) , the drive connector member (30) has a connector extension (32) , and a compression spring (34) fits around connector extension (32) .

The louvre drive couplings (28) have an interior end wall (36) with a central hole (not shown) . The connector extension (32) passes through the hole , and the compression spring (34) (in phantom) is captive , by the interior end wall (36) within the louvre drive couplings (28) . In this way the compression spring (34) biasses the drive connector member (30) outwardly from the louvre drive couplings (28) , into the drive socket member (26) of the control drive members (16) .

20 In order to release the drive connector member (30) from engagement in the drive socket member (26) , to permit removal of an individual louvre (14) , the drive connector member (30) has a manually engageable operating device , which in this case comprises a knob (38) , extending out from a slot (40) in the louvre drive couplings (28) . This knob (38) can be operated by a thumb or finger, to slide the

1296C110

drive connector member (30 ) against the compression spring (34 ) .

The drive connector member (30 ) can be manually locked in this disengaged position by means of a manually operable lock button (42 ) which engages in recess (44 ) in the drive connector member (30 ) . This holds the drive connector member (30 ) in its withdrawn position, out of drive socket member (26 ) of control drive members (16 ) .

The same operation can be done at the opposite end of the louvre (14 ) , if desired, although in many cases the disengagement of the drive connector member (30 ) at one end of the louvre (14 ) will be enough to permit the louvre (14 ) to be removed.

10 In order to replace the louvre (14 ) , the louvre ( 14 ) is placed in position. If both drive connector members (30 ) , of the one louvre have been retracted, then the operator simply release the lock button at one end, and then at the other. This permits the compression spring (34 ) to advance the drive connector member (30 ) outwardly, into the drive socket member (30 ) of the control drive members (16 ) , for reinstallation of the louvre (14 ) , in the shutter .

The actual operating mechanism may be located in both side frames, or only one, if desired. The rotatable sleeves (18 ) (or equivalent ) would be provided in both side frames, to provide rotatable support for each louvre.

20 If desired, for safety of operation, a simple clutch (50 ) (Fig 4) can be incorporated in for example drive connector (30 ) . The clutch would provide for slippage, in the event of over rotation of the control mechanism, and thereby prevent damage .

According to a further embodiment it is possible to employ a similar design for releasing

1296C110

individual louvres, while avoiding the formation of slotted openings in the louvres themselves.. This is particularly advantageous when using for example wooden louvres, where the wood is solid. It can also be helpful when using hollow louvres made of metal or plastic, since it avoids numerous additional fabrication steps.

This further embodiment is illustrated in Figures 6, and 7.

In this embodiment the louvres (14) are connected to respective drive hubs (62) at each end of each louvre, as before .

This connection is achieved, in this embodiment , by means of a driven sleeve (64) secured in one , or preferably both, ends of each louvre . Sleeve (64) may be typically  
10 an injection moulding, and is embedded in and secured along the central axis of the louvre. Sleeve (64) has a generally cylindrical body, sized to fit between the opposite side walls of a hollow louvre (14) . Spring loaded connector members (66) connect the hubs to the sleeves.

Slots (68) are formed in hubs (62).

A tool (70) formed with an angular end (72) is made to fit within slots (68).

By inserting the end of the tool into a slot, the drive connector member may be slid back against the spring, thus releasing the louvre from the hub.

The foregoing is a description of a preferred embodiment of the invention which is given here by way of example only. The invention is not to be taken as limited to any of the  
20 specific features as described, but comprehends all such variations thereof as come within the scope of the appended claims.

THE EMBODIMENTS OF THE INVENTION IN WHICH AN EXCLUSIVE PROPERTY OR PRIVILEGE IS CLAIMED ARE DEFINED AS FOLLOWS:

1. A shutter having a frame, and a plurality of louvres extending from side to side within the frame, the louvres being rotatable about parallel axes and having a control mechanism within at least one side of the frame for operating all louvres and comprising;
  - a plurality of control drive assemblies in said control mechanism for engaging respective said louvres ;
  - a louvre drive coupling in each of said plurality of louvres, for inter-engagement with respective said control drive assemblies comprising a socket defining interior drive surfaces mounted in respective said louvre drive couplings;
  - a slot formed in a side of each said socket;
  - a moveable drive connector member slidably received in each said socket for connecting between each said louvre drive coupling and a respective said control drive assembly;
  - a manually engageable operating device coupled with each said drive connector member and extending outwardly from said slot in said socket and being manually operable to move said drive connector member between engaged and disengaged positions to release a respective said louvre from its respective said control drive assembly;
  - a respective biasing device in each said respective louvre drive coupling urging a respective said drive connector member into said engaged position and being yieldable to permit movement of said drive connector member out of said engaged

position; and,

a locking pin member in said socket and engageable with said drive connector member and operable to hold said drive connector member in its disengaged position.

2. A shutter as claimed in Claim 1 and including respective drive socket members in respective said control drive assemblies, and respective said drive connectors being slideable relative to respective said sockets.

3. A shutter as claimed in Claim 2 and including drive surfaces in each said socket, and wherein said drive connector has drive faces complementary to said drive surfaces in said socket.

4. A shutter as claimed in Claim 2 and wherein said drive sockets in respective said control drive assemblies are of generally rectangular interior shape.

5. A shutter as claimed in Claim 4 and wherein each of said control drive assemblies has a generally cylindrical rotatable body portion, and at least one lever arm extending outwardly from said body portion operable to rotate said body portion.

6. A shutter as claimed in Claim 5 and including control operating rods extending between respective said lever arms of adjacent said control drive assemblies operable to cause operation of all said lever arms and all of said control drive assemblies simultaneously.

1/5

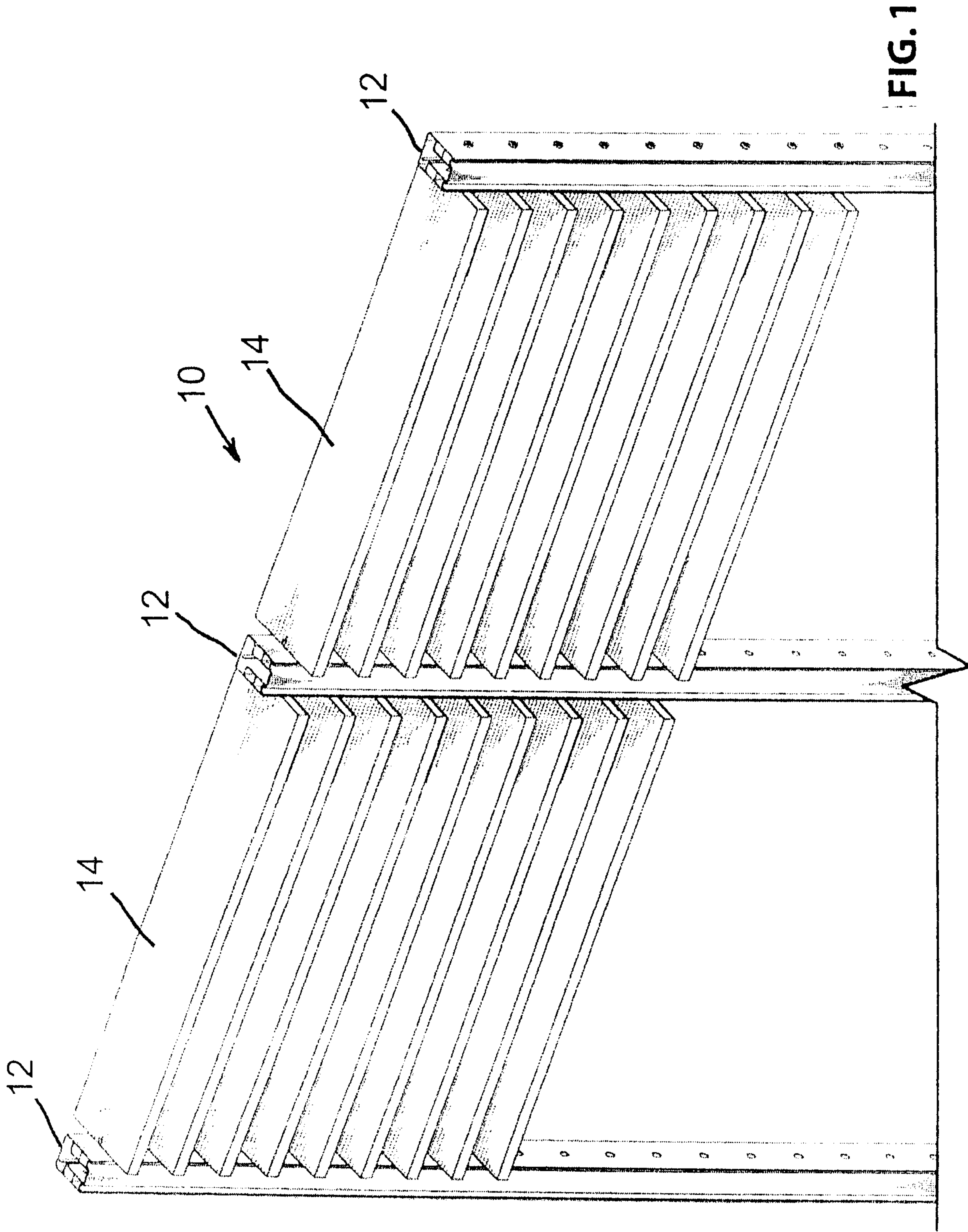

FIG. 1

2/5

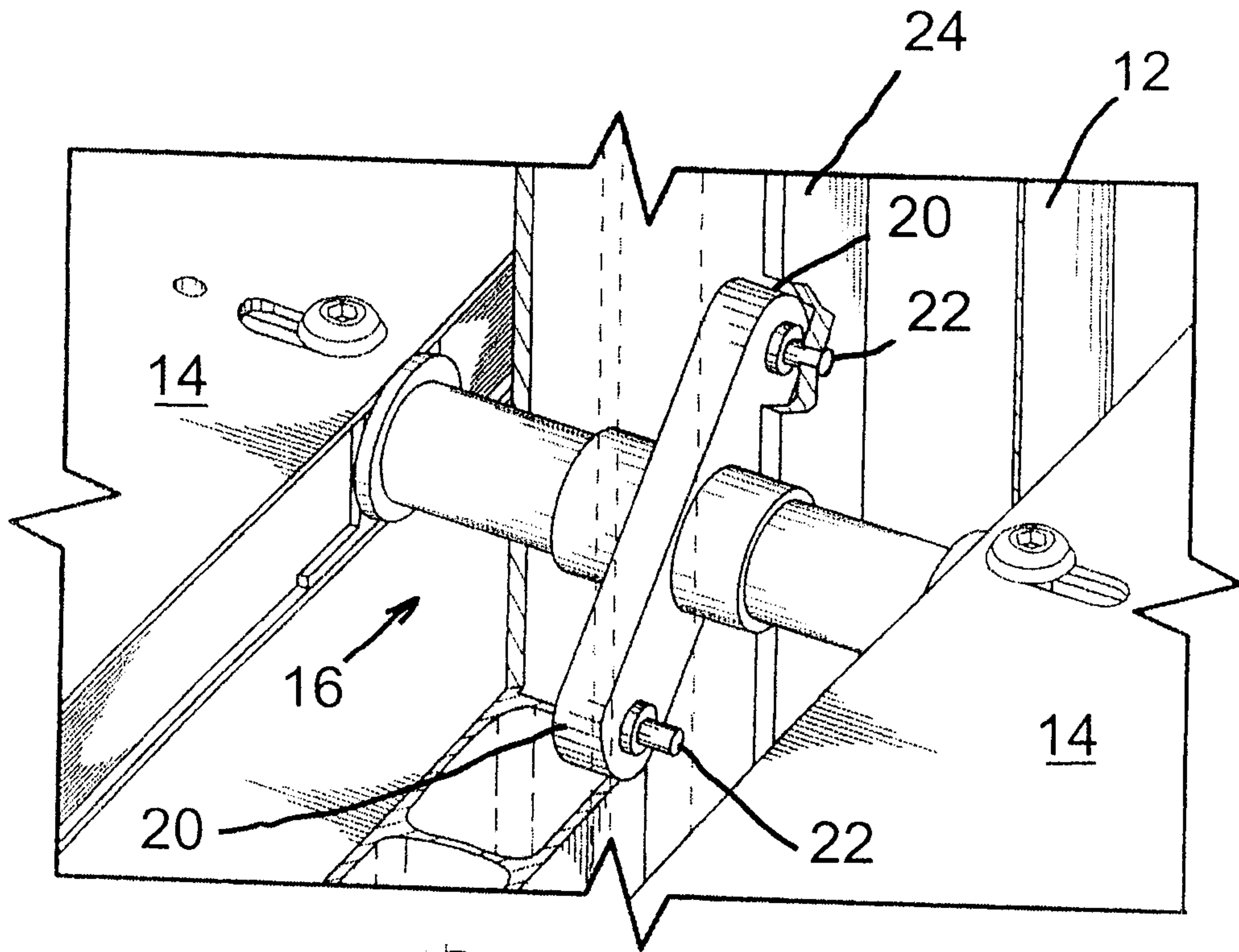

FIG. 2

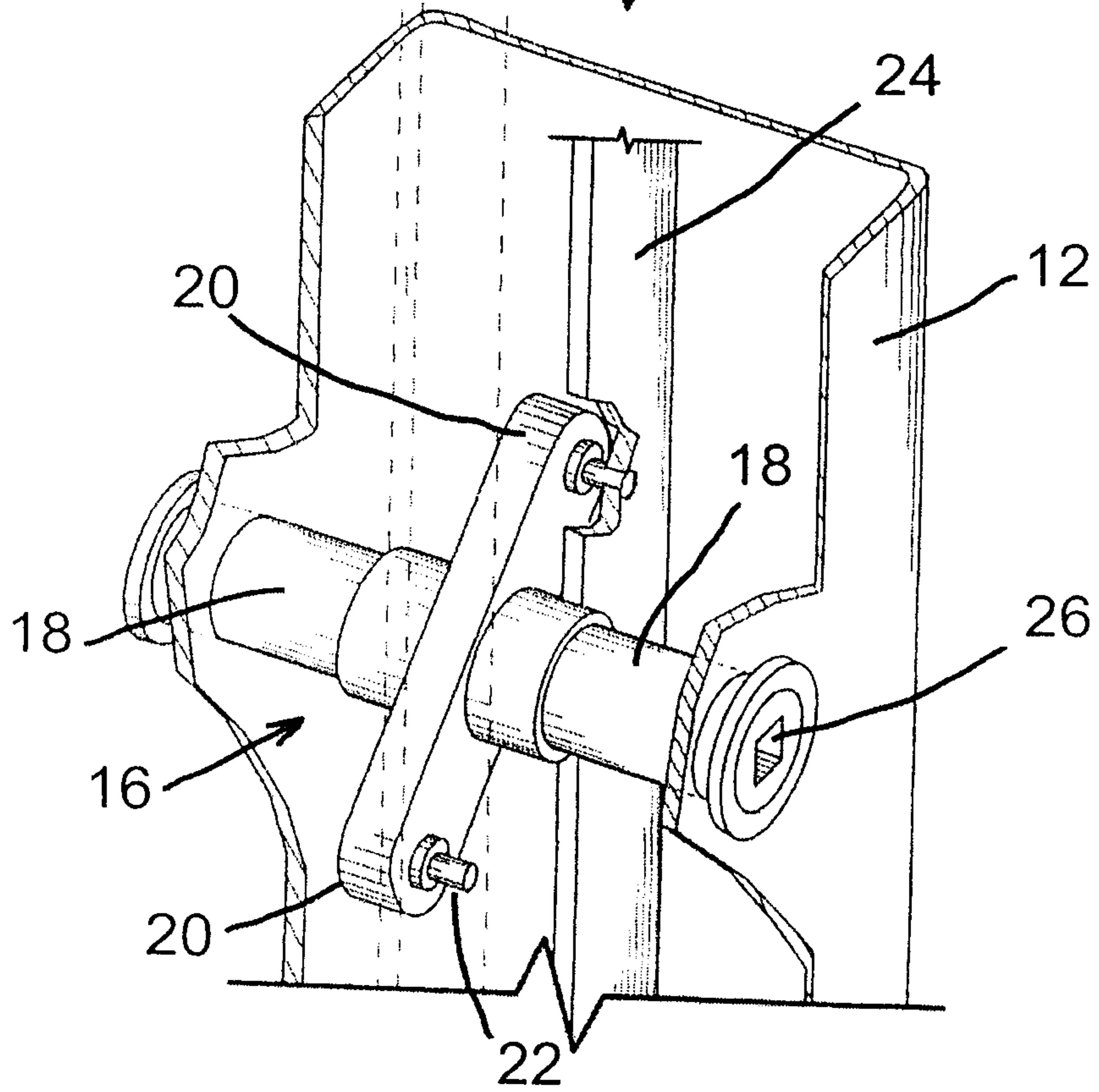

FIG. 3

3/5

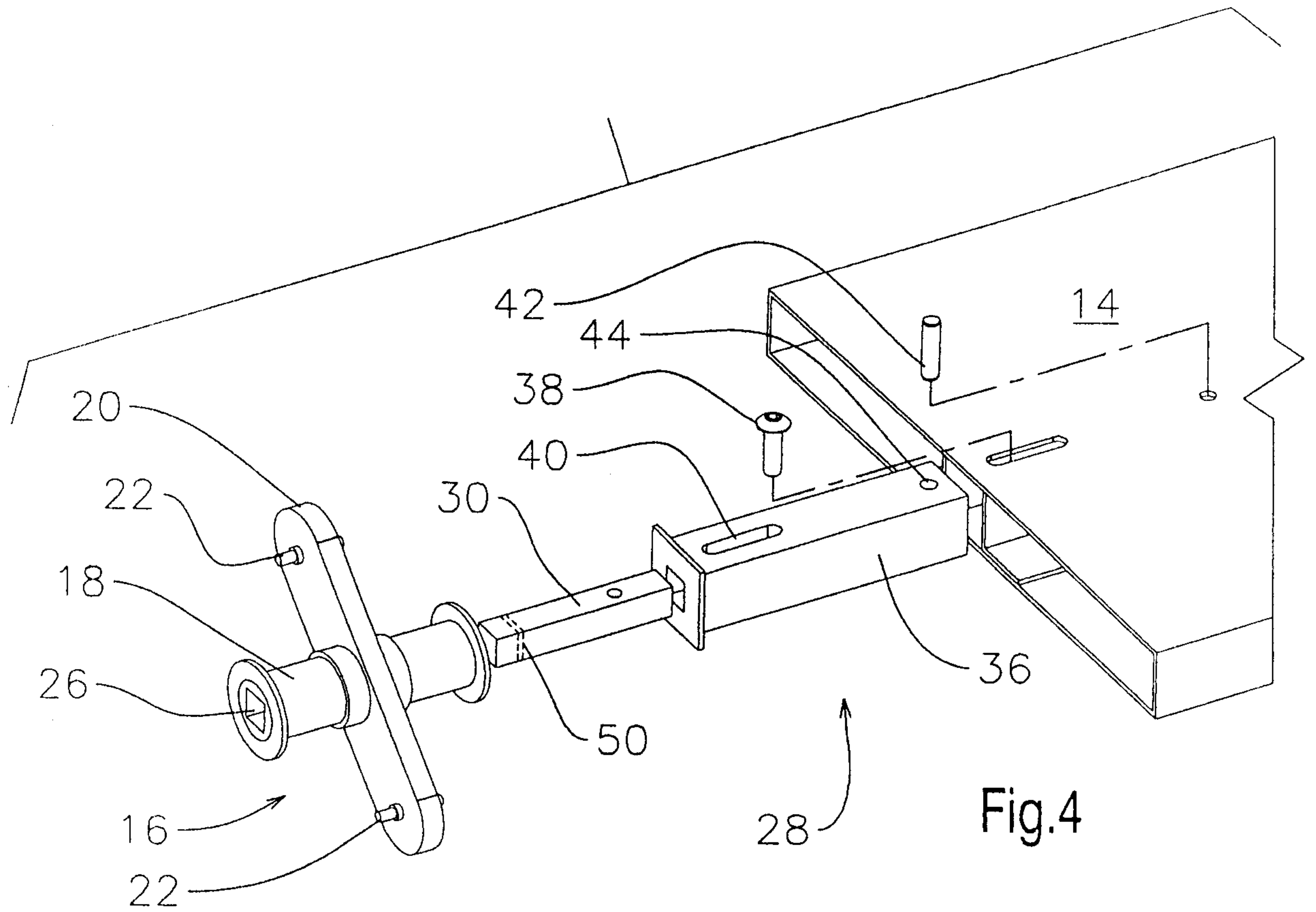

Fig.4

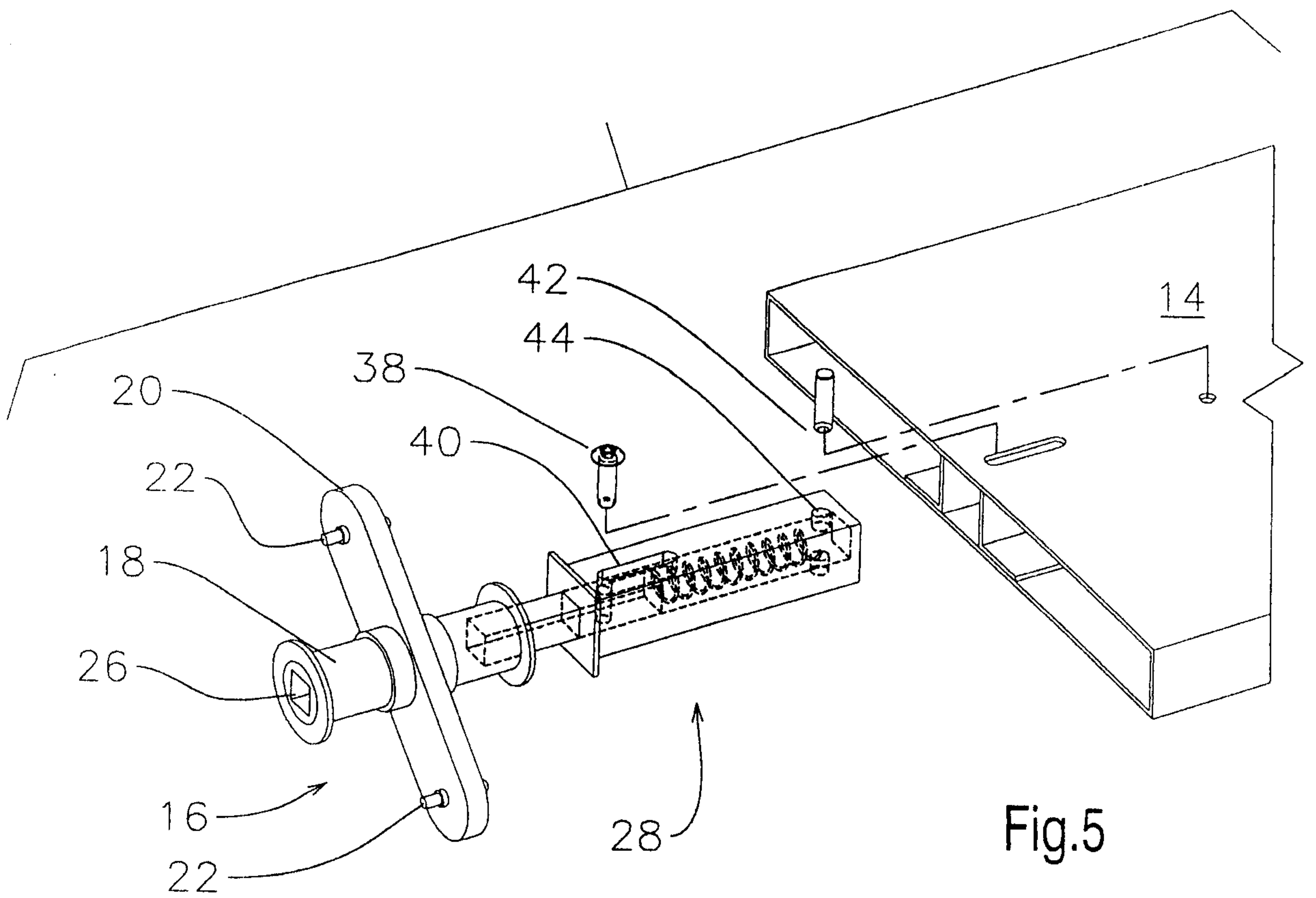

Fig.5

4/5

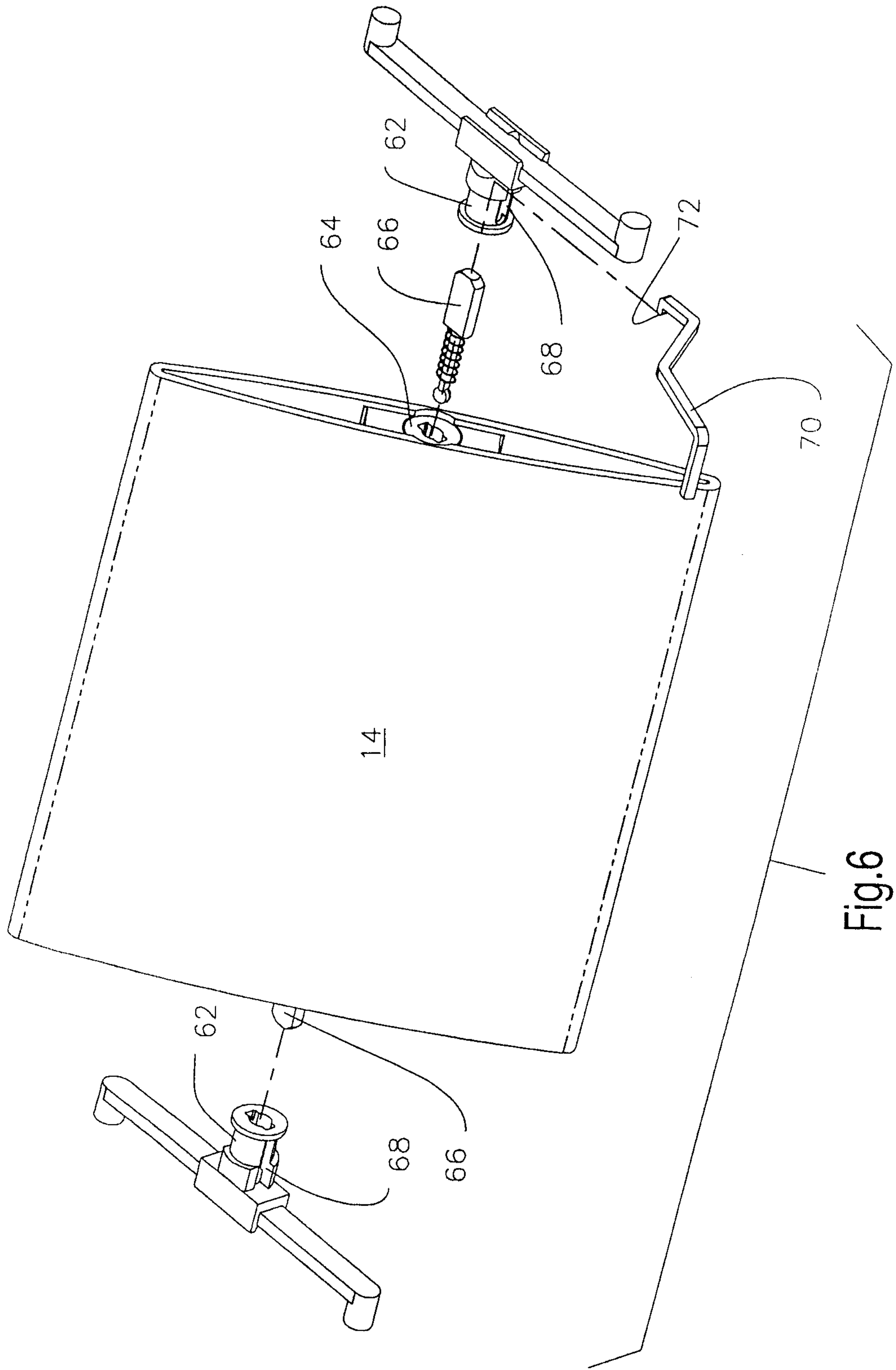

Fig.6

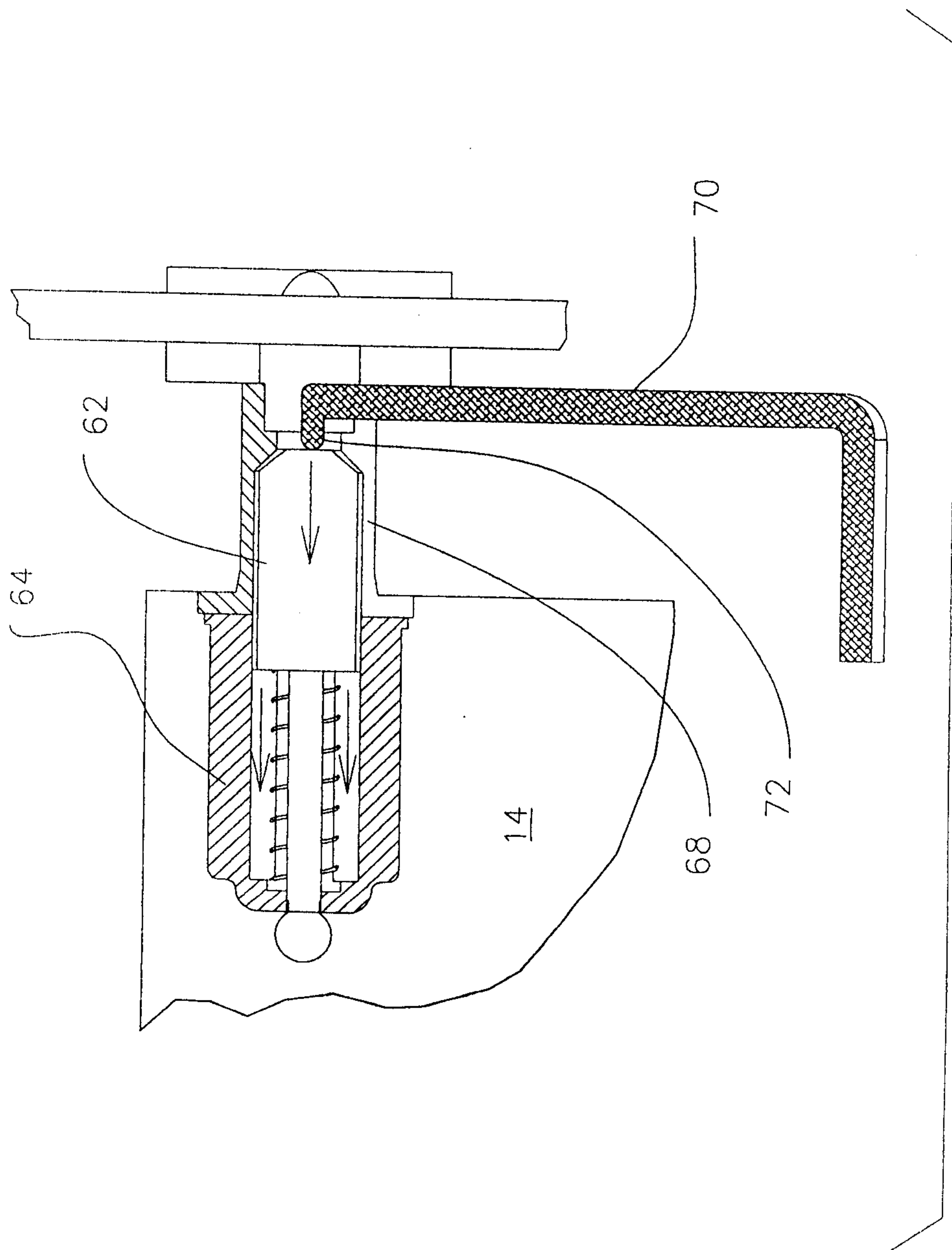

Fig. 7

