

(19) **DANMARK**

(10) **DK/EP 3835627 T3**



(12) **Oversættelse af  
europæisk patentskrift**

Patent- og  
Varemærkestyrelsen

- 
- (51) Int.Cl.: **F 16 L 17/03 (2006.01)** **F 16 J 15/02 (2006.01)**
- (45) Oversættelsen bekendtgjort den: **2025-04-28**
- (80) Dato for Den Europæiske Patentmyndigheds bekendtgørelse om meddelelse af patentet: **2025-02-19**
- (86) Europæisk ansøgning nr.: **20212625.6**
- (86) Europæisk indleveringsdag: **2020-12-09**
- (87) Den europæiske ansøgnings publiceringsdag: **2021-06-16**
- (30) Prioritet: **2019-12-11 US 201916710028**
- (84) Designerede stater: **AL AT BE BG CH CY CZ DE DK EE ES FI FR GB GR HR HU IE IS IT LI LT LU LV MC MK MT NL NO PL PT RO RS SE SI SK SM TR**
- (73) Patenthaver: **Krausz Industries Ltd., 6 Hapatish Street, 6655906 Tel Aviv, Israel**
- (72) Opfinder: **Chiproot, Avi, 12 Hairis Street, 4427814 Kfar-Saba, Israel**
- (74) Fuldmægtig i Danmark: **Dennemeyer & Associates S.A, P.O. Box 700425, DE-81304 Munich, Tyskland**
- (54) Benævnelse: **KOMPRESSIBEL FORSEGLING TIL RØRSPÆNDE**
- (56) Fremdragne publikationer:  
**EP-A1- 2 679 872**  
**WO-A1-2010/080742**  
**US-A- 3 647 229**  
**US-A1- 2010 148 452**  
**US-A1- 2016 208 964**



# DESCRIPTION

Description

## FIELD OF THE INVENTION

[0001] The present invention relates generally to clamps and grip rings for pipes, and particularly to improving the compressibility of hydraulic seal assemblies for clamps.

## BACKGROUND OF THE INVENTION

[0002] Fig. 1 illustrates a prior art seal 1, which includes a sealing ring 2 with an outer portion 3 folded over an inner portion 4 so as to define an inner annular space 5 between and bounded by the inner and outer portions 4 and 3. The inner annular space 5 is in fluid communication with a fluid (e.g., water, not shown) flowing in a pipe sealed by seal 1. The fluid enters inner annular space 5 via one or more apertures (not shown) formed in a side wall of sealing ring 2 and the fluid applies pressure in inner annular space 5 to increase tightening of the seal.

[0003] The seal is generally used in clamping rings, the ends of which are tightened by bolts to squeeze and press the seal against the outer perimeter of one or more pipes. It is important to note that the seal is confined in an inner annular portion of the clamping ring.

[0004] A problem has occurred with seals of this type. Although the seal is made of rubber or other resilient material, it has been found that the seal does not compress easily because the inner annular portion of the clamping ring limits and suppresses any possible bulging of the seal. As a result, the seal's hardness increases, the seal behaves quite rigidly and a significant tightening force must be generated by the bolt in order to squeeze the seal against the pipe.

[0005] The seal typically has a hardness of 80 Shor. An intuitive solution is to make the seal of a softer material, such as 70 Shor; however, in practice it has been found that this does not solve the problem because the confined seal's hardness increases during tightening such that even 70 Shor increases to 90 Shor or more. On the other hand, it is not possible to start off with a very soft rubber because there is a lower limit in many applications as to the hardness of the rubber which is required to achieve a proper seal on the pipe and a limit according to certain standards for seals.

[0006] EP 2 679 872 A1 discloses a seal according to the preamble of claim 1 of the present disclosure, consisting of a multilayer annular seal assembly including at least one outer sealing

ring including at least one inner annular space and at least one inner sealing ring formed with one or more inner annular chambers.

**[0007]** WO 2010/080742 A1 discloses a pipe coupling seal including a cylindrical elastomeric seal including annular pad portions axially spaced apart from one another and extending from a bridge portion, each of the pad portions being thicker than the bridge portion and adapted to seal against an outer diameter of a pipe.

**[0008]** US 3 647 229 A discloses a seal for use between the bell of one of two telescoped pipe ends and the spigot of the other pipe end. It is symmetrical and comprises a plurality of encircling perforate ears on its outer surface, with the tips of the ears in pressure contact with the inner surface of the bell. There is a single tubular opening located radially inward from each tip and also a tubular opening near each edge of the seal below the abovementioned openings.

**[0009]** US 2010/148452 A1 discloses a sealing assembly for a liquid conveying system including a first structure defining an aperture. A second structure is received in the aperture. And an annular seal is disposed within the aperture for radially sealing between the first structure and the second structure. The seal includes an outer radial portion embedded in the first structure and an inner radial portion in sealing engagement with the second structure.

**[0010]** US 2016/208964 A1 discloses a pipe coupling capsulation assembly including a band having an inner annular seal element wrappable around a pipe, opposing clamp members that extend from the band, and one or more tightening elements for clamping together the clamp members. Retaining elements are assembled to the annular seal element.

## **SUMMARY OF THE INVENTION**

**[0011]** The present invention seeks to provide an improved seal for pipe clamps which is more readily compressible and solves the above problem, as is described more in detail hereinbelow.

**[0012]** There is thus provided in accordance with an embodiment of the present invention a seal including a sealing ring constructed with a first portion folded over a second portion so as to define at least one inner annular space bounded by the first and second portions, and at least one hollow portion which is at least partially annular, formed in the sealing ring in the first portion and/or second portion.

**[0013]** The at least one hollow portion may extend 360° around the sealing ring; alternatively, it may subtend an angle less than 360° over a portion of the sealing ring.

**[0014]** The hollow portion may be located more radially outward or inward of the at least one inner annular space.

**[0015]** There may be more than one hollow portion symmetric about a central axis of a cross-section of the sealing ring.

**[0016]** There may be more than one hollow portion asymmetric about a central axis of a cross-section of the sealing ring.

**[0017]** The at least one hollow portion may include an at least partially annular rib.

#### **BRIEF DESCRIPTION OF THE DRAWINGS**

**[0018]** The present invention will be understood and appreciated more fully from the following detailed description, taken in conjunction with the drawing in which:

Fig. 1 is a sectional illustration of a prior art seal;

Fig. 2 is a sectional illustration of a seal, constructed and operative in accordance with a non-limiting embodiment of the present invention; and

Figs. 3A and 3B are simplified sectional illustrations of the seal, constructed and operative in accordance with the present invention.

#### **DETAILED DESCRIPTION OF EMBODIMENTS**

**[0019]** Reference is now made to Fig. 2, which illustrates a seal 10, constructed and operative in accordance with a non-limiting embodiment of the present invention.

**[0020]** Seal 10 includes a sealing ring 12 constructed with a first portion 14 (outer means more radially outward) folded over a second portion 16 so as to define at least one inner annular space 18 between and bounded by the first and second portions 16 and 14. The first portion 14 may be in some applications the radially outer portion but in other applications may be the radially inner portion, or the outer or inner axial portion or other configurations. The inner annular space 18 is in fluid communication with a fluid (e.g., water, not shown) flowing in a pipe sealed by seal 10. The fluid may enter inner annular space 18 via one or more apertures 19 formed in a side wall of sealing ring 12 (preferably through the inner side wall of first portion 14, but alternatively could be through second portion 16). The fluid applies pressure in inner annular space 18 to increase tightening of the seal.

**[0021]** Seal 10 is formed with at least one hollow portion 20 which is at least partially annular. This means that hollow portion 20 may be fully annular (that is, extends 360° around the sealing ring 12) or partially annular (that is, subtends an angle less than 360° over a portion of

the sealing ring 12). The illustrated embodiment in Fig. 2 shows two such hollow portions 20, but the invention is not limited to this number. The hollow portions 20 may be symmetric about a central axis 220 of a cross-section of sealing ring 12, or alternatively may be asymmetric about axis 220.

**[0022]** The hollow portion 20 is formed in sealing ring 12 either more radially outward or more radially inward of the inner annular space 18. The one or more hollow portions 20 may be located in first portion 14; additionally or alternatively they may be located in second portion 16 as show in broken lines in Fig. 2 (which is offset to the left of the axis 220 in the figure). The cross-sectional shape of the hollow portion may be circular (as in the upper portions of the figure) or non-circular, such as elliptical (as in the lower portion of the figure) or any other shape.

**[0023]** It has been surprisingly found that the hollow portion or portions 20 solve the abovementioned problem and significantly reduce the force required to tighten the seal against the pipe, without compromising the functionality of the seal and without changing the material hardness.

**[0024]** Reference is now made to Figs. 3A and 3B, which illustrate different variations of the embodiment of Fig. 2. In Fig. 3A, at least one of the hollow portions 20 includes an at least partially annular rib 22. As before, this means that rib 22 may be fully annular (that is, extends 360° around the sealing ring 12) or partially annular (that is, subtends an angle less than 360° over a portion of the sealing ring 12); the subtended angle may be different than the subtended angle of hollow portion 20.

**[0025]** In the left hollow portion of Fig. 3A, rib 22 is a full partition, separating hollow portion 20 into two portions 20A and 20B. In the right hollow portion of Fig. 3A, rib 22 is only a partial partition. In Fig. 3A, rib 22 is "vertical" in the sense of the drawing, meaning it is radial with respect to the center of the sealing ring 12.

**[0026]** In the left hollow portion of Fig. 3B, rib 22 is not radial with respect to the center of the sealing ring 12, but instead is tilted from a radial direction. In the right hollow portion of Fig. 3B, rib 22 is cross-shaped.

**[0027]** The addition of the rib 22 may be used to adjust the stiffness/rigidity of the seal 10. Moreover, the shape and position of rib 22 may be used to achieve non-uniform rigidity of the seal for certain applications.

## **REFERENCES CITED IN THE DESCRIPTION**

Cited references

This list of references cited by the applicant is for the reader's convenience only. It does not form part of the European patent document. Even though great care has been taken in compiling the references, errors or omissions cannot be excluded and the EPO disclaims all liability in this regard.

**Patent documents cited in the description**

- [EP2679872A1 \[0006\]](#)
- [WO2010080742A1 \[0007\]](#)
- [US3647229A \[0008\]](#)
- [US2010148452A1 \[0009\]](#)
- [US2016208964A1 \[0010\]](#)

**KOMPRESSIBEL FORSEGLING TIL RØRSPÆNDE****PATENTKRAV**

1. Forsegling (10), som omfatter:
  - en forseglingsring (12) konstrueret med en første del (14) foldet over en anden del (16) for at definere mindst et indvendigt ringformet hulrum (18) afgrænset af ovennævnte første og anden del (16, 14); og
  - mindst en hul del (20), som er mindst delvist ringformet, formet i ovennævnte forseglingsring (12) i mindst en af ovennævnte første del (14) og ovennævnte anden del (16),
  - hvor i ovennævnte ene hule del (20) omfatter en mindst delvist ringformet stiver (22), og forseglingen (10) er kendetegnet ved at ovennævnte ringformede stiver (22) er tværformet.
2. Forsegling (10) ifølge krav 1, hvor i ovennævnte mindst ene hule del (20) strækker sig 360° omkring ovennævnte forseglingsring (12).
3. Forsegling (10) ifølge krav 1, hvor i ovennævnte mindst ene hule del (20) ligger lige over for en vinkel, der er mindre end 360° over en del af ovennævnte forseglingsring (12).
4. Forsegling (10) ifølge krav 1, hvor i ovennævnte mindst ene hule del (20) omfatter mere end en hul del (20), som er symmetrisk omkring en central akse (220) af et tværsnit af ovennævnte forseglingsring (12).
5. Forsegling (10) ifølge krav 1, hvor i ovennævnte mindst ene hule del (20) omfatter mere end en hul del (20), som er asymmetrisk omkring en central akse (220) af et tværsnit af ovennævnte forseglingsring (12).
6. Forsegling (10) ifølge krav 1, hvor i ovennævnte mindst ene hule del (20) er placeret mere radiale udad fra ovennævnte mindst ene indvendige ringformede hulrum (18).

7. Forsegling (10) ifølge krav 1, hvori ovennævnte mindst ene hule del (20) er placeret mere radiale indad fra ovennævnte mindst ene indvendige ringformede hulrum (18).
8. Forsegling (10) ifølge krav 1, hvori en tværsnitsform af ovennævnte mindst ene hule del (20) er cirkulær.
9. Forsegling (10) ifølge krav 1, hvori en tværsnitsform af ovennævnte mindst ene hule del (20) er ikke-cirkulær.
10. Forsegling (10) ifølge krav 1, hvori ovennævnte ringformede stiver (22) er en fuld opdeling, der separerer ovennævnte mindst ene hule del (20) i to dele (20A, 20B).
11. Forsegling (10) ifølge krav 1, hvori ovennævnte ringformede stiver (22) hældes fra en radial retning.

# DRAWINGS

Drawing

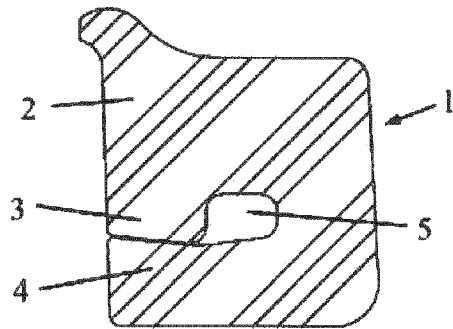

FIG. 1  
PRIOR ART

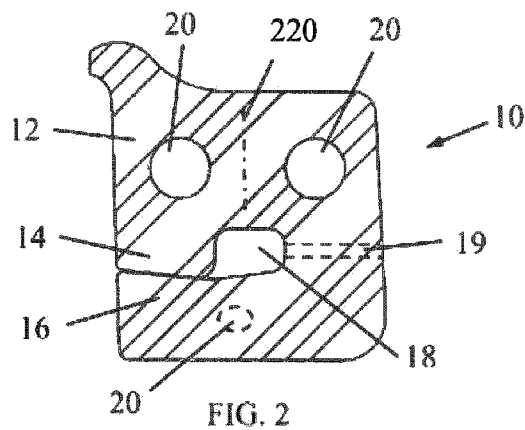

FIG. 2

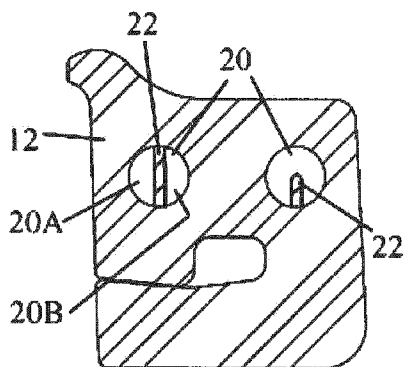

FIG. 3A

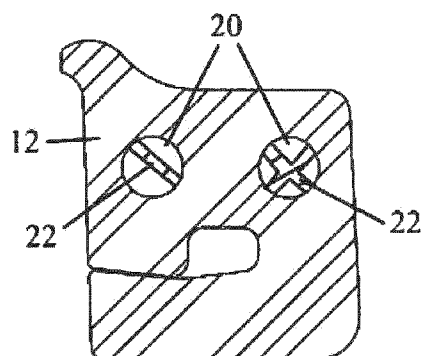

FIG. 3B