

No. 617,532.

Patented Jan. 10, 1899.

C. A. JUENGST.  
METAL PLANER.

(Application filed July 21, 1898.)

(No Model.)

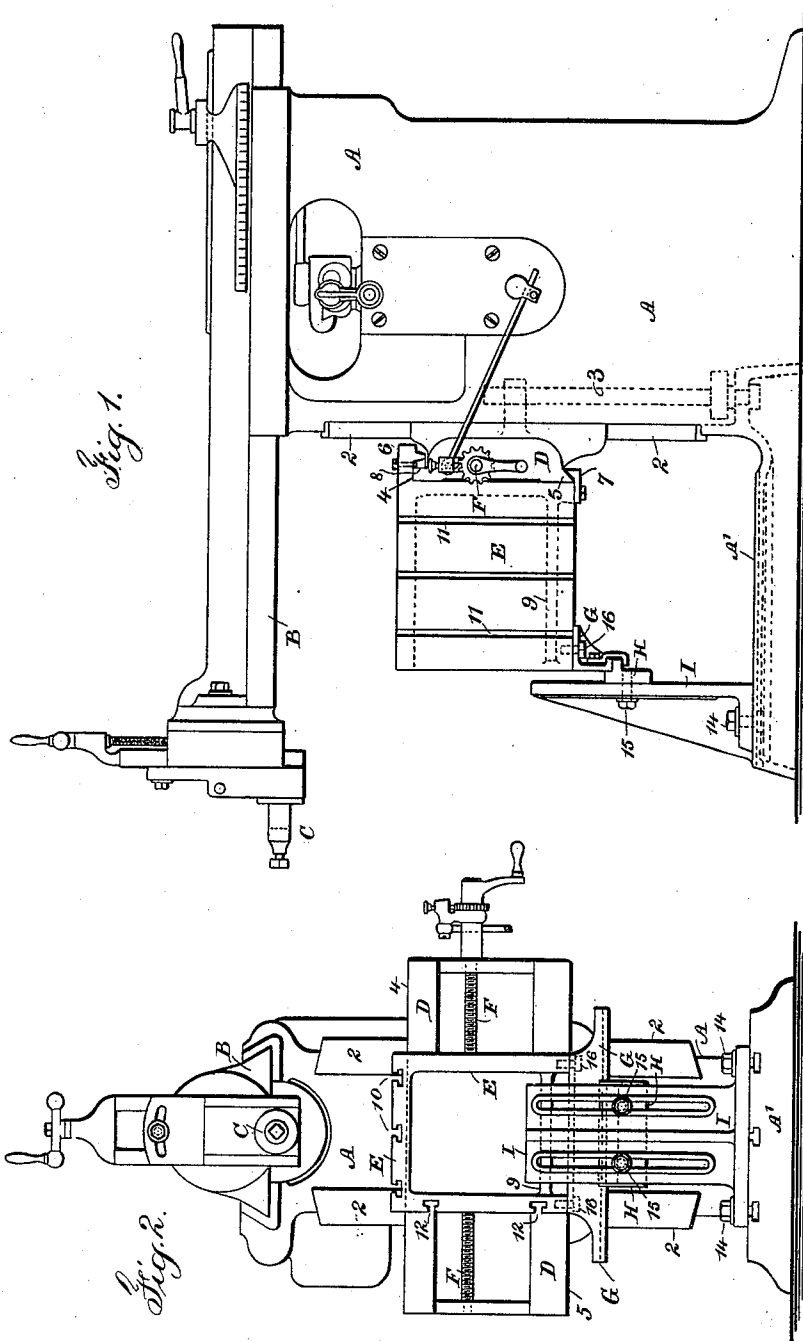

Witnesses  
Chas. H. Smith  
J. Staib

Inventor  
Charles A. Juengst  
by L. H. Serrell & Son  
attys

# UNITED STATES PATENT OFFICE.

CHARLES A. JUENGST, OF CROTON FALLS, NEW YORK.

## METAL-PLANER.

SPECIFICATION forming part of Letters Patent No. 617,532, dated January 10, 1899.

Application filed July 21, 1898. Serial No. 686,494. (No model.)

*To all whom it may concern:*

Be it known that I, CHARLES A. JUENGST, a citizen of the United States, residing at Croton Falls, in the county of Westchester and State of New York, have invented an Improvement in Metal-Planers, of which the following is a specification.

Metal-planing machines have heretofore been made in which the tool is carried by a bar that is reciprocated horizontally, or nearly so, by the action of either a crank or a rack and pinion and fitted in slides at the upper end of a column or frame, and upon the side of this column or frame a work-table has been supported by slides, and the article to be planed has either been fastened upon the work-table or held by a vise or other clamping device supported by the work-table, and this work-table has been movable laterally upon the transverse slide and actuated by a screw progressively as the planing operation has taken place. In consequence of the work-table projecting somewhat similar to a bracket at one side of the column there has been a tendency in the parts to spring, so that the tool does not make such a clean and reliable cut at the end of the stroke as at the commencement, and efforts have been made to strengthen the supporting device or work-table by a leg fastened upon such work-table and passing down and sliding upon the extended base; but the lower end of this leg necessarily slides upon the surface of the extended base, and difficulty has been experienced in making the extended base at the lower end of the column perfectly parallel with the transverse slide, because the work-table cannot be properly supported if the leg bears with greater weight upon the extended base at one place than at another, and it is difficult to prevent a trembling motion in the parts, because the lower end of the leg is at such a distance from the transverse slide and the supporting devices. Besides this, the metal chips falling upon the extended base are liable to interfere with the movement of the leg.

The object of the present invention is to support the work-table closely adjacent to its under and outer edge by a stationary slide that can be adjusted to the position of the work-table and will sustain the weight of the

parts and effectually prevent any vibration of the work-table under the action of the cutter upon the article that is being planed. 55

In the drawings, Figure 1 is a side elevation showing the present improvement and illustrating the relative positions of the well-known devices to my said improvement, and Fig. 2 is a similar elevation at right angles to Fig. 1. 60

The column or frame A is made with an extended base A', as usual, and at the upper end of this column is the reciprocating bar B, which is provided with a tool-holder C and is reciprocated by the action of a crank, gearing, or other well-known appliances, and these parts being old do not require further description. 65

Upon one side of the column or frame A are the V guides or slides 2, receiving the stock of the transverse slide D, and this transverse slide and the parts carried by it can be raised or lowered and fastened in any desired position, according to the work to be performed. Usually this transverse slide is raised or lowered and held by a screw, and in the form of the machine shown in the drawings this screw is usually within the column or frame A and is only illustrated by the dotted lines at 3. 70

It is to be understood that the transverse slide has top and bottom edges 4 and 5, that are parallel and level, or nearly so, as usual, and the work-table E is made with a hook 6 resting upon the top parallel edge 4 and with an adjustable lip 7 engaging the lower V-shaped parallel edge 5, and there is a gib at 8 that is adjusted by screws, as usual, to prevent any loosening of the parts. 75

In constructing this machine the work-table E is to be of any desired size or shape, according to the character of work to be performed. I have shown such table as rectangular and hollow, there being a shelf at 9, passing across between one vertical side and the other, and in the top of the work-table there are undercut grooves or channels 10 and similar channels 12, that are horizontal, in one vertical side of the work-table, and other channels 11 in the opposite vertical side of the work-table, which channels 11 are vertical, so that in these channels screw-heads or other similar appliances may be 80  
90  
100

availed of in clamping to the work-table either the article to be operated upon or a vise for holding such article. These appliances being well known do not need further description.

I remark that in consequence of the shelf 9 being slightly above the bottom edges of the work-table sides such bottom edges can be planed off true with the top surface, so that the work-table can be made rectangular, and I remark that in constructing this machine it is usually advantageous to plane off the top surface of the table by the action of a tool held in the holder C, the work-table being supported upon the transverse slide D and moved gradually by the action of a screw F, that is provided, as usual, for moving the table longitudinally of the stock or slide D, and after the top surface of the table has been properly planed off the table can be turned upside down and the bottom edges of the sides of the table planed so that such bottom edges are perfectly parallel to the top surface of the table, and the sides of the work-table can be planed off in any ordinary planer, as usual.

The special feature of the present invention relates to a slider G, that is bolted to the under and outer portion of the work-table, and this slider rests upon an adjustable slide H, supported by a movable upright or column I, that is held upon the extended base A' by the screws 14, and there are bolts 15, by which the slide H is held to the column I, such bolts passing through vertical slots in the column I, as illustrated in Fig. 2.

The slider G can be bolted to the lower edges of the sides of the work-table E by bolts or screws 16, so as to be firmly connected thereto, and the top and bottom edges of this slider G being parallel the slide H can be raised and brought into contact with the lower edge of the slider, so that any desired proportion of the weight of the work-table can rest by the slider G upon the slide H, and in consequence of the column I being firmly bolted to the extended base A' there will be no vibration or jerking movement of the slider as it moves along upon the slide H, because this slide H is parallel to the surface of the work-table, as before described, and the work-table will be supported against any vibratory movement from the cutter as it acts upon the article that is being planed, and the slider can be moved, with the work and table, progressively by the machine as the planing operation is performed, the slider taking the same amount of strain and weight

at all places and under all circumstances, so that the work performed in the planing operation is much more perfect than in machines heretofore constructed.

It will be apparent that the movable column, the adjustable slide, and the slider are adapted to any desired size or shape of table, and where the table may require to be changed according to the work to be performed such table can be adapted to receive upon its under and outer edge the slider G, and the column I and slide H can be placed, adjusted, and secured to suit the position of the slider G.

I do not limit myself to the slider being attached to the lower outer edge of the work-table, as such slider may be connected at any desired place at the outer end of such work-table, and if desired hook-straps may be used, as shown, the same being bolted to the slider and passing below the rib of the slide.

I claim as my invention—

1. The combination with the vertical column and its extended base and the work-table and means for holding and moving the same, of a slider at the outer end of the table, a movable column supported by the extended base and an adjustable slide upon the column for supporting the slider at the outer end of the work-table, substantially as set forth.

2. The combination in a metal-planing machine with the column and transverse slide, of a work-table and means for supporting and sliding the same upon the transverse slide, a removable slider and means for attaching the same upon the outer end of the work-table, a vertical slotted column, means for attaching the same to the extended base of the planing-machine and a slide and screws passing through the slots of the column and into the slide whereby the slide is adjusted and held so as to support the slider and work-table as they are moved transversely, substantially as set forth.

3. The combination in a metal-planing machine with the column and transverse stock, of a work-table and means for supporting and sliding the same on the transverse stock, a vertical column and means for attaching the same upon the extended base of the planing-machine and a slide thereon, and a slider connected with the work-table and moving on the slide, substantially as set forth.

Signed by me this 19th day of July, 1898.

CHAS. A. JUENGST.

Witnesses:

GEO. T. PINCKNEY,  
E. E. POHLÉ.