

(19) **DANMARK**

(10) **DK/EP 2319997 T3**



(12)

Oversættelse af
europæisk patentskrift

Patent- og
Varemærkestyrelsen

-
- (51) Int.Cl.: **E 03 F 5/04 (2006.01)**
- (45) Oversættelsen bekendtgjort den: **2017-08-28**
- (80) Dato for Den Europæiske Patentmyndigheds bekendtgørelse om meddelelse af patentet: **2017-07-12**
- (86) Europæisk ansøgning nr.: **10189639.7**
- (86) Europæisk indleveringsdag: **2010-11-02**
- (87) Den europæiske ansøgnings publiceringsdag: **2011-05-11**
- (30) Prioritet: **2009-11-05 NL 2003760**
- (84) Designerede stater: **AL AT BE BG CH CY CZ DE DK EE ES FI FR GB GR HR HU IE IS IT LI LT LU LV MC MK MT NL NO PL PT RO RS SE SI SK SM TR**
- (73) Patenthaver: **Easy Sanitary Solutions B.V., Nijverheidsstraat 60, 7575 BK Oldenzaal, Holland**
- (72) Opfinder: **Keizers, Jurgen Hendrik Peter Jozeph, Hofkamp 182, 7582 GH, Lossers, Holland**
- (74) Fuldmægtig i Danmark: **Plougmann Vingtoft A/S, Rued Langgaards Vej 8, 2300 København S, Danmark**
- (54) Benævnelse: **Afløb uden rist**
- (56) Fremdragne publikationer:
WO-A1-2007/086734
DE-U1-202008 003 050
DE-U1-202009 004 446
FR-A1- 2 766 905
GB-A- 2 270 836
GB-A- 2 282 156
US-A- 6 125 593
US-A1- 2002 057 945
US-A1- 2008 141 595

DESCRIPTION

[0001] The invention relates to a shower drain according to the preamble of claim 1. Such a shower drain is known from GB 2282156.

[0002] Shower drains are frequently used in walk-in showers. The advantage of elongate shower drains is that the slope of the shower floor can be laid in one direction. It is hereby also possible to use large tiles for the shower floor without these large tiles having to be cut into small pieces in order to obtain the correct slope to the shower drain.

[0003] These prior art elongate shower drains are usually laid under the door of the walk-in shower or against a wall or in the middle of a floor. The shower drains comprise a receptacle with a bottom and upright walls along the periphery of the bottom. A grating is then laid in this receptacle so that the upper side of the grating lies roughly flush with the upper surface of the tiled floor. Although this provides for a flat floor, the fitting of such a drain is sometimes awkward because the length of the shower drain often does not correspond with the space available between for instance two walls. It can thus occur that the thickness of the tiles on the wall is not taken into account, so that after tiling the grating can no longer be removed from the receptacle. Nor can such a receptacle-like drain be readily made to size during fitting. If the receptacle were to be sawn to size, at least one side wall would hereby be lost.

[0004] It is further not desirable in a prior art shower drain to use the drain without grating. Because the receptacle has vertical side walls, the transition of the tiled floor to the drain is abrupt. A person standing on this transition will experience an unpleasant sensation.

[0005] Cleaning of such a shower drain is moreover difficult, since the grating must first be removed to enable cleaning of the receptacle itself, and the grating itself, which often comprises many small openings, must also be cleaned. A layer of dirt and bacteria further forms on the underside of a grating. Since the underside of the grating is out of sight, a grating will often be cleaned too late, this being undesirable in for instance hospitals from a hygiene viewpoint. It is now an object of the invention to provide a drain such as a shower drain, wherein the above stated drawbacks are alleviated or even obviated.

[0006] GB 2270836 is related to a similar field as the invention, but does not disclose a shower drain. This document discloses a shower tray, which forms the full floor of a shower space. The drain disclosed in this publication is a small circular or square drain, which does not even have the advantages or the features of known shower drains.

[0007] GB 2282156 discloses a elongate shower drain, wherein the bottom slopes in longitudinal direction towards the outlet opening.

[0008] This object is achieved according to the invention with a drain according to claim 1

[0009] Because the bottom rises from the underside of the side wall to the second longitudinal edge, there results a gradual transition between the upper side of the tiled floor and the drain. Someone standing on the edge of the drain will not experience an unpleasant sensation since the transition is gradual.

[0010] The transition between the upper side of the tiled floor and the drain is not necessarily completely flat. There may be a small height difference. The maximum height difference depends on the position of the drain in the floor. If the drain lies in the middle of a floor and a user can stand thereon with their full weight, a smaller difference in height is then desirable than if the drain lies against a wall and it is less likely that a user can stand on the drain with their full weight.

[0011] In addition, a grating can be omitted in such a drain according to the invention. Manufacturing costs will hereby remain low. Such a drain without grating can further be cleaned in simple manner.

[0012] Because a grating is not necessary, no account need be taken of pressure load in the lower receptacle as a result of a grating.

[0013] A drain without grating also has an advantage when being sold since a wide variety of gratings need not be supplied with the drain. This is in contrast to a prior art drain where there is a wide variety of gratings. In an embodiment of the drain according to the invention a horizontal wall part is arranged between the first longitudinal edge and the depending side wall. Tiles can for instance be placed on this horizontal wall part when the drain is arranged against a rear wall. The visible part of the drain is hereby reduced.

[0014] In another embodiment of the drain according to the invention a depending flange is arranged on the first longitudinal edge. This flange removes a part of the drain from view since a chamber is formed behind the flange. In a drain according to the invention a draining opening is arranged in the bottom. A siphon and outlet pipe can then be connected to this draining opening. A siphon is preferably incorporated into this outlet pipe. Because the bottom rises there is more space available under the drain than in a prior art shower drain. The siphon can hereby be arranged closer against the bottom.

[0015] In yet another embodiment of the drain according to the invention the draining opening extends to a position close to the underside of the side wall. This ensures that the drain will empty to a large extent or even completely, and that no draining water remains in the drain. The bottom preferably slopes toward the draining opening in the lengthwise direction of the drain.

[0016] In a highly preferred embodiment of the drain according to the invention the drain is an extruded profile. The advantage of an extrusion element is that great lengths of drain can easily be made of substantially any desired cross-section. In addition, an extrusion element can also be easily made to size.

[0017] In addition, it is also possible to manufacture the drain by bending of a metal sheet. The advantage hereof is that the drain consists of one whole, and welded joints or other disruptive transitions are not therefore visible, or even not present. A drain from a bent sheet can further end on either side in a flange optionally provided with a small recess. This provides the option of making the drain to size in simple manner by shortening the flange.

[0018] Sealing elements are preferably arranged on either side of the extruded profile for sealing the drain on the end surfaces. These can be metal plugs optionally struck together with a sealing compound into the end surfaces of the extrusion profile. It is also possible to provide plastic sealing elements. The plastic elements can easily be made by means of injection moulding.

[0019] It is further also possible in such an embodiment to lengthen the drain by means of a coupling piece.

[0020] In yet another embodiment a grating is arranged between the two parallel longitudinal edges. Although a grating is not essential for a drain according to the invention, it may be desired from aesthetic viewpoint to nevertheless arrange a grating.

[0021] The bottom can further be flat or the bottom can be curved.

[0022] The invention further relates to a combination of two drains according to the invention, wherein the second longitudinal edges of the two drains are mutually abutting.

[0023] With this combination it is possible to provide a drain without grating, which can be arranged in the middle of a floor surface. Even if someone stands on the combination according to the invention, this will still not be perceived as unpleasant.

[0024] These and other features according to the invention are further elucidated with reference to the accompanying drawings.

Figure 1 shows a perspective view of a first embodiment of the invention.

Figure 2 shows a cross-sectional view of the embodiment according to figure 1.

Figure 3 shows a first embodiment of a combination according to the invention.

Figures 4A-4F show cross-sectional views of different embodiments according to the invention.

Figure 5 shows a second embodiment of a combination according to the invention.

Figure 6 shows an eighth embodiment of a drain according to the invention.

Figures 7A and 7B show cross-sectional views of a ninth embodiment of a drain according to the invention.

Figure 1 shows a first embodiment of a drain 1 according to the invention. Drain 1 has a first longitudinal edge 2 and a second longitudinal edge 3 running parallel to this first longitudinal edge 2. A depending flange 4 is arranged on the first longitudinal edge 2. Further running from the first longitudinal edge 2 is a horizontal wall part 5 which subsequently transposes into a vertical side wall 6.

[0025] Arranged on the underside of side wall 6 is a bottom 7 which rises toward the second side wall 3. Arranged in the bottom is a draining opening 8 which connects to for instance a siphon and an outlet pipe 9.

[0026] Sealing elements 10 are arranged in drain 1 in order to ensure that drain 1 is sealed on both sides. These sealing elements 10 can be manufactured from plastic or other suitable material, for instance stainless steel.

[0027] Figure 2 shows a cross-sectional view of drain 1 according to figure 1. Wall tiles 11 are arranged on the horizontal wall part 5. Drain 1 is thus partially incorporated into the wall.

[0028] A depending edge 12 and a horizontal flange 13 are further arranged on the second longitudinal edge 3 so that flange 13 protrudes below floor tiles 14. A sealing membrane can for instance be arranged on this flange 13.

[0029] Figure 3 shows a cross-sectional view of a combination 20 according to the invention. This combination consists of two drains 21, 22. Each drain has a first longitudinal edge 23, 24, a horizontal wall part 25, 26 running from this first longitudinal edge 23, 24, a side wall 27, 28 and a rising bottom 29, 30.

[0030] Both rising bottoms 29, 30 come together at a common second longitudinal edge 31 which is parallel to both longitudinal edges 23, 24. Floor tiles 32 are arranged on either side of combination 20.

[0031] The upper surface of floor tiles 32 lies substantially flush with the second longitudinal edge 31. If a person now steps with foot V onto the combination 20 according to the invention, this person will then feel little difference in level, since bottom 29, 30 rises to the second longitudinal edge 31.

[0032] Figures 4A to 4F show different cross sections of embodiments according to the invention. The same elements are designated in these figures with the same reference numerals.

[0033] Figures 4A to 4F show a drain 40 with a first longitudinal edge 41, a second longitudinal edge 42, a side wall 43 and a rising bottom 44. In each shown drain 40 a horizontal wall part 45 is further arranged between first longitudinal edge 41 and side wall 43.

[0034] Further arranged in figures 4A, 4D, 4E and 4F is an edge 46 depending from the second longitudinal edge 42 and having a horizontal flange 47 arranged thereon. A sealing membrane can for instance be arranged on this flange 47 for a reliable seal between drain 40 and a surrounding tiled floor.

[0035] Figure 4F shows a drain 40, wherein the horizontal wall part 45 is relatively long so that a chamber 48 is formed under the horizontal wall part 45. Arranged on the horizontal wall part 45 is a finishing strip 49 which is for instance of the same material as the surrounding tiles 50. Only a relatively narrow opening 51 is hereby visible, while owing to chamber 48 drain 40 has a sufficiently large discharge capacity.

[0036] Figure 5 shows a combination 60 according to the invention. This combination 60 has two drains 61, 62, each with a bottom 65, 66 running downward from a respective second longitudinal edge 63, 64. Bottoms 65, 66 join together.

[0037] Depending from each second longitudinal edge 63, 64 is a side wall 67, 68 with a respective horizontal flange 69, 70.

[0038] A platform 71 is arranged in the middle of combination 60. This platform 71 has two mutually opposite longitudinal edges 72, 73 which, together with the associated second longitudinal edges 63, 64, form inflow openings.

[0039] Figure 6 shows a cross-sectional view of a drain 80. This drain 80 has many similarities with drain 40 of figure 4E.

[0040] Drain 80 has a first longitudinal edge 81. Running from this first longitudinal edge 81 is a horizontal wall part 82 which connects to side wall 83. Connecting to the underside of side wall 83 is a rising bottom 84 which ends in the second longitudinal edge 85 of drain 80. This rising bottom 84 extends over the whole length of drain 80.

[0041] Preferably provided centrally in bottom 84 is a draining opening 86 which provides access to a chamber 87 arranged under bottom 84. In the bottom of this chamber 87 is arranged a second draining opening 88 which in turn connects to a siphon 89 and an outlet pipe 90.

[0042] The advantage of second chamber 87 is that the actual draining opening 88 is invisible. The first draining opening 86 can be narrow and elongate so that there is sufficient throughflow area, while the second draining opening can be formed such that a conventional siphon 89 can be connected thereto.

[0043] Figures 7A and 7B show a drain 100. The cross-section of the drain shown in figure 7A is present along the whole length. Also arranged here from the first longitudinal edge 101 is a horizontal wall part 102 and a side wall 103 running downward therefrom. From the underside of side wall 103 a bottom 104 once again runs upward and ends in the second longitudinal

edge 105. Further arranged hereon is then a horizontal flange 106 for attachment of a sealing membrane for a tile floor.

[0044] Integrated into the drain along the length of drain 100 is a siphon, the cross-section of this drain being shown in figure 7B. Arranged for this purpose in bottom 104 is a draining opening 107 which debouches in a second chamber 108 arranged under bottom 104. Water flowing into this second chamber 108 will then rise upward and pass over overflow edge 109 and thus enter third chamber 110 and be discharged via outlet pipe 111.

[0045] In the above shown embodiments 80, 100 with second chamber 87, 108 it is possible to have the second chamber 87, 108 run along the whole length of drain 80, 100.

REFERENCES CITED IN THE DESCRIPTION

This list of references cited by the applicant is for the reader's convenience only. It does not form part of the European patent document. Even though great care has been taken in compiling the references, errors or omissions cannot be excluded and the EPO disclaims all liability in this regard.

Patent documents cited in the description

- [GB2282156A \[0001\] \[0007\]](#)
- [GB2270836A \[0006\]](#)

Patentkrav

1. Bruseafløb (1; 20; 40; 60; 80; 100), hvilket bruseafløb er langstrakt og omfatter:

- 5 - to parallelle langsgående kanter (2, 3; 23, 24, 31; 41, 42; 63, 64, 72, 73; 81, 85; 101, 105), der grænser en indløbsåbning;
- en sidevæg (6; 27, 28; 43; 83; 103), der hænger ned fra en første langsgående kant (2; 23, 24; 41; 63, 64; 81; 101); og
- en bund (7; 29, 30; 44; 65, 66; 84; 104), hvor en afløbsåbning (8; 86, 88; 107) er anbragt i bunden (7; 29, 30; 44; 65, 66; 84; 104),
- 10

kendetegnet ved at bunden (7; 29, 30; 44; 65, 66; 84; 104) stiger fra undersiden af sidevæggen (6; 27, 28; 43; 83; 103) til den anden langsgående kant (3; 31; 42; 72, 73; 85; 105).

- 15 **2.** Afløb (1; 20; 40; 80; 100) ifølge krav 1, hvor en horisontal vægdel (5; 25, 26; 45; 82) er anbragt mellem den første langsgående kant (2; 23, 24; 41; 81; 101) og den nedhængende sidevæg (6; 27, 28; 43; 83; 103).

- 3.** Afløb (1; 40; 80; 100) ifølge krav 2, hvor en nedhængende flange (4) er
20 anbragt på den første langsgående kant (2; 41; 81; 101).

4. Afløb ifølge krav 1, hvor afløbsåbningen strækker sig til en position tæt på undersiden af sidevæggen.

- 25 **5.** Afløb ifølge krav 1 eller 4, hvor bunden hælder mod afløbsåbningen i længderetningen af afløbet.

6. Afløb (1; 20; 40; 60; 80; 100) ifølge et hvilket som helst af de foregående krav, hvor afløbet (1; 20; 40; 60; 80; 100) er en ekstruderet profil.

7. Afløb (1; 20; 40; 60; 80; 100) ifølge krav 6, hvor tætningselementer (10) er
5 anbragt på hver side af den ekstruderede profil til tætning af afløbet (1; 20; 40; 60; 80; 100) på endefladerne.

8. Afløb (60) ifølge et hvilket som helst af de foregående krav, hvor en rist (71) er anbragt mellem de to parallelle langsgående kanter (63, 64).

10

9. Afløb (40) ifølge et hvilket som helst af de foregående krav, hvor bunden (44) er flad.

10. Afløb (1; 20; 40; 60; 80; 100) ifølge et hvilket som helst af 1-8, hvor bunden
15 (7; 29, 30; 44; 65, 66; 84; 104) er krum.

11. Kombination (20; 40) af to afløb ifølge et hvilket som helst af de foregående krav, hvor de andre langsgående kanter (31; 42) af de to afløb (20; 40) gensidigt tilstøder hinanden.

20

DRAWINGS

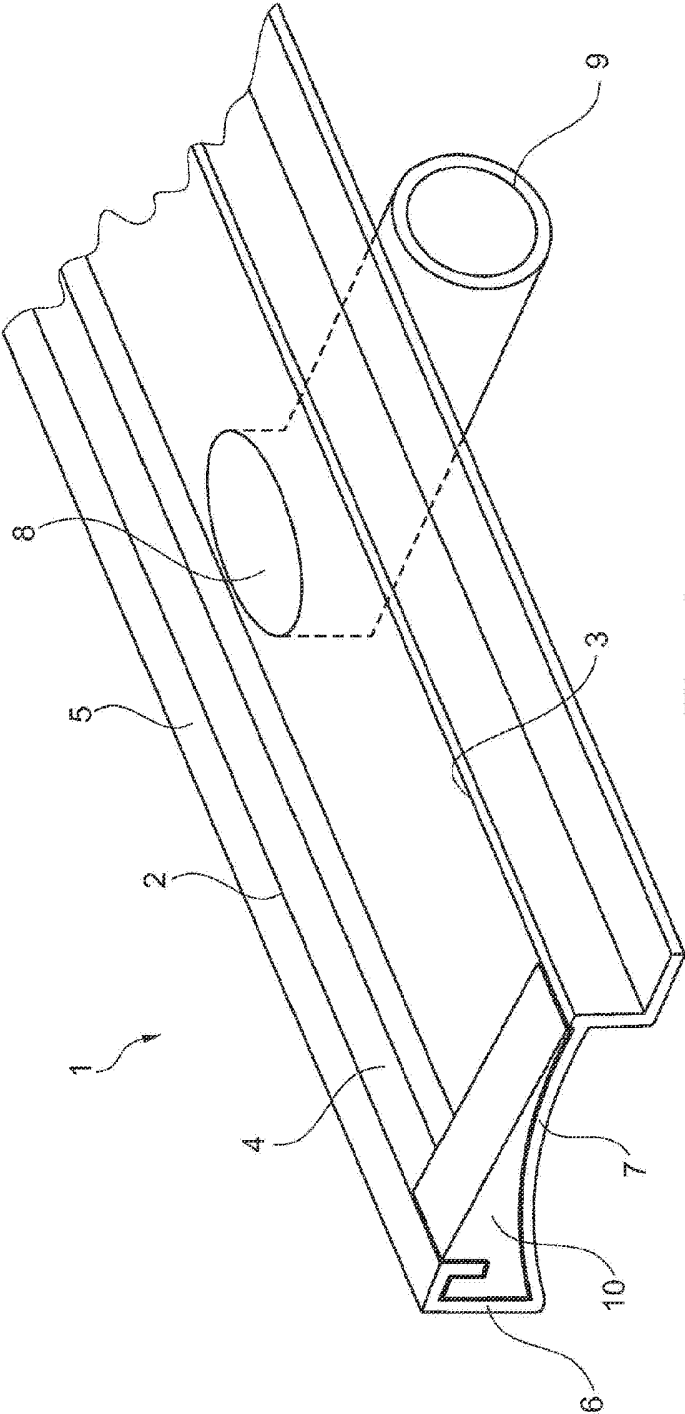

Fig. 1

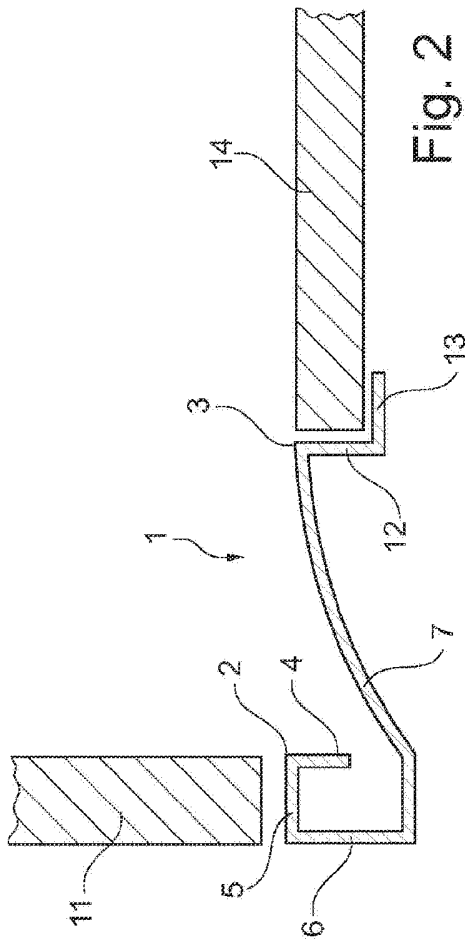

Fig. 2

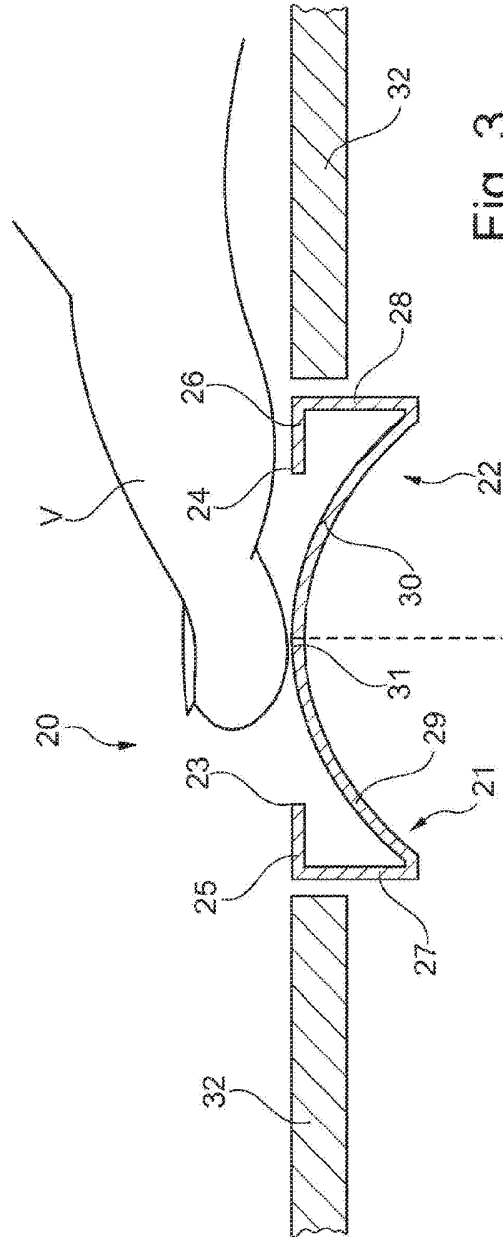

Fig. 3

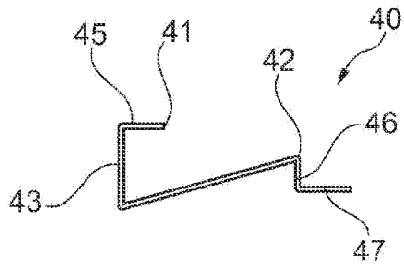

Fig. 4A

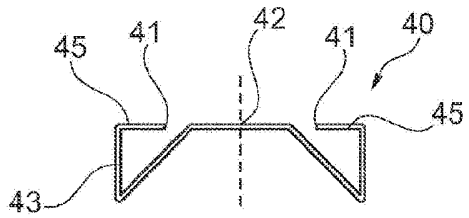

Fig. 4B

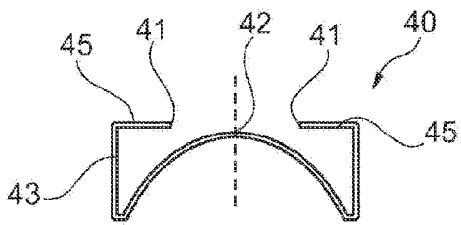

Fig. 4C

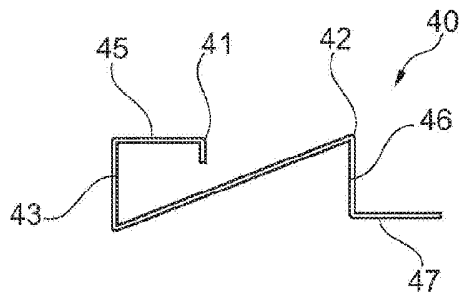

Fig. 4D

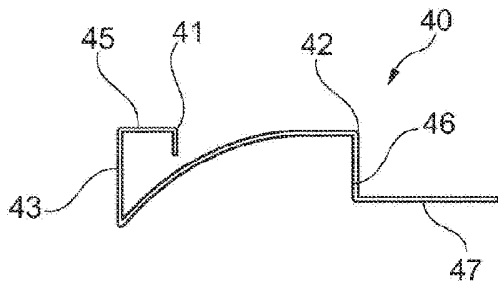

Fig. 4E

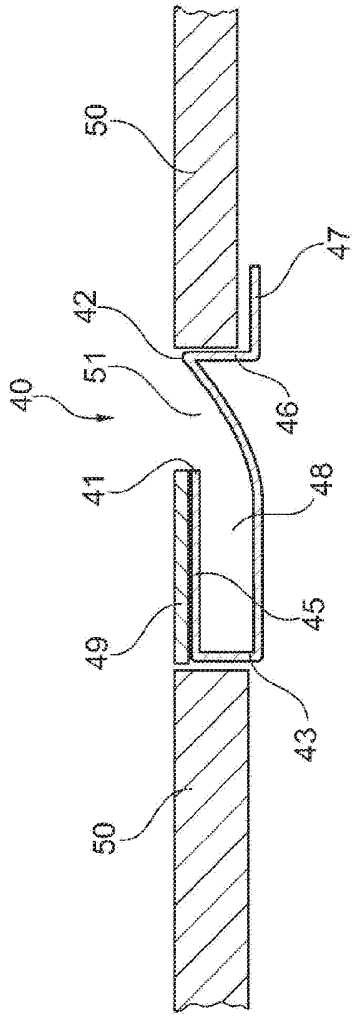

Fig. 4F

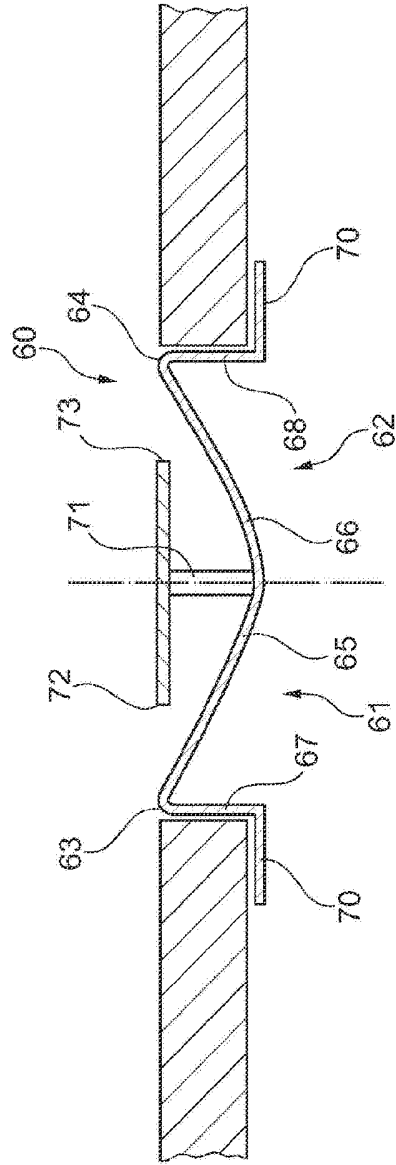

Fig. 5

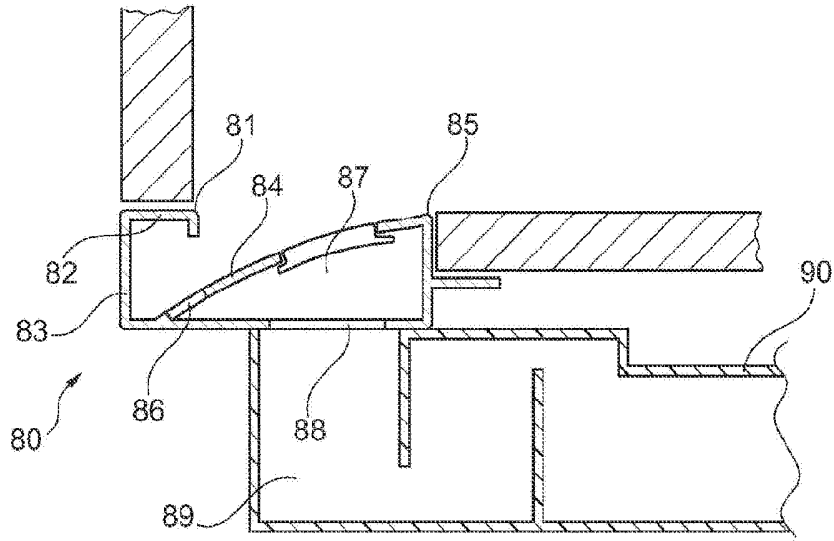

Fig. 6

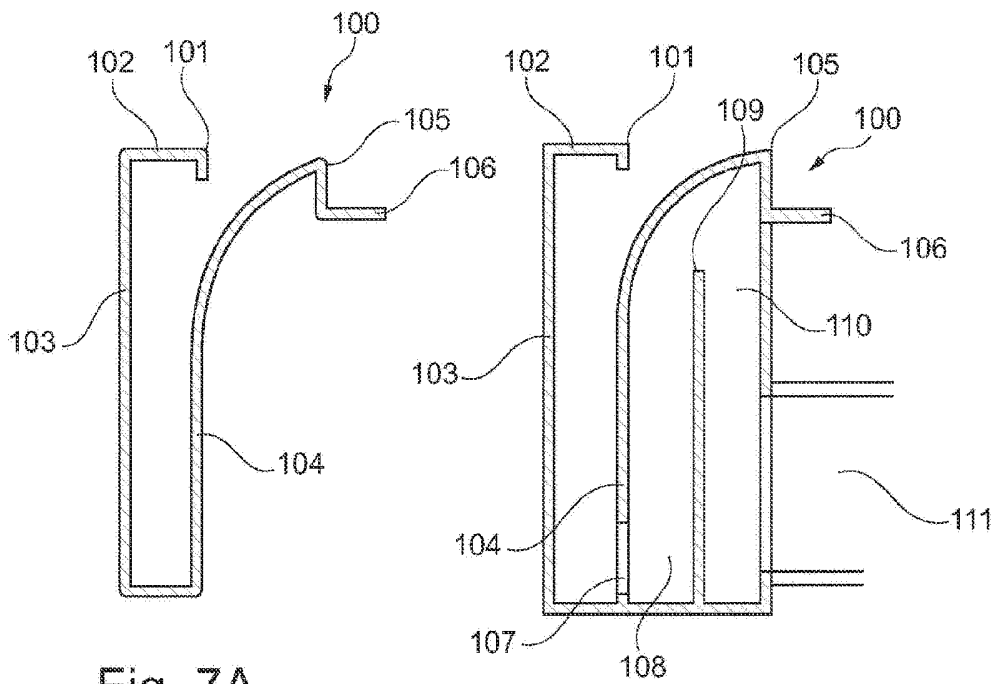

Fig. 7A

Fig. 7B