



US00D349984S

United States Patent [19]

[11] Patent Number: **Des. 349,984**

Essex et al.

[45] Date of Patent: **** Aug. 23, 1994**

[54] **VACUUM CLEANER CONVERTER**

5,060,339 10/1991 Evers 15/344
5,092,015 3/1992 Kosten et al. 15/338

[75] Inventors: **John D. Essex**, North Canton;
Ronald J. Stephens, Rittman, both of Ohio

OTHER PUBLICATIONS

Regina Owner's Manual Models DM 1700 & DM 1800 ©1991.

[73] Assignee: **The Hoover Company**, North Canton, Ohio

Eureka "Bravo" Upright Vacuum Cleaner Owner's Guide 9000 series ©1990.

[**] Term: **14 Years**

Primary Examiner—Ruth McInroy

[21] Appl. No.: **1,776**

[57] CLAIM

[22] Filed: **Nov. 23, 1992**

The ornamental design for a vacuum cleaner converter, as shown and described.

[52] U.S. Cl. **D32/31**

[58] Field of Search 15/323, 329, 332, 334,
15/338; D32/25, 30-32

DESCRIPTION

[56] References Cited

U.S. PATENT DOCUMENTS

D. 260,901	9/1981	Vermillion	D32/32
D. 273,623	4/1984	Vermillion	D32/31
2,450,172	9/1948	Stoner	211/86
2,996,748	8/1961	Gitzendanner .	
3,872,538	3/1975	Crouser	15/323
3,955,237	5/1976	Chateauneuf	15/323
4,541,142	9/1985	Pudwell	15/323
4,695,022	9/1987	Mendonsa et al.	248/176
4,700,428	10/1987	Hetherington	15/338

FIG. 1 is a left side elevational view of a vacuum cleaner converter showing our new design, the elements shown in broken lines are for illustrative purposes only and form no part of the claimed design; FIG. 2 is an enlarged left side elevational view thereof, the right side being a mirror image; FIG. 3 is an enlarged front elevational view thereof; FIG. 4 is an enlarged top plan view thereof; FIG. 5 is an enlarged rear elevational view thereof; FIG. 6 is an enlarged bottom plan view thereof; and, FIG. 7 is an enlarged partial cross sectional view taken along line 7-7 in FIG. 4.

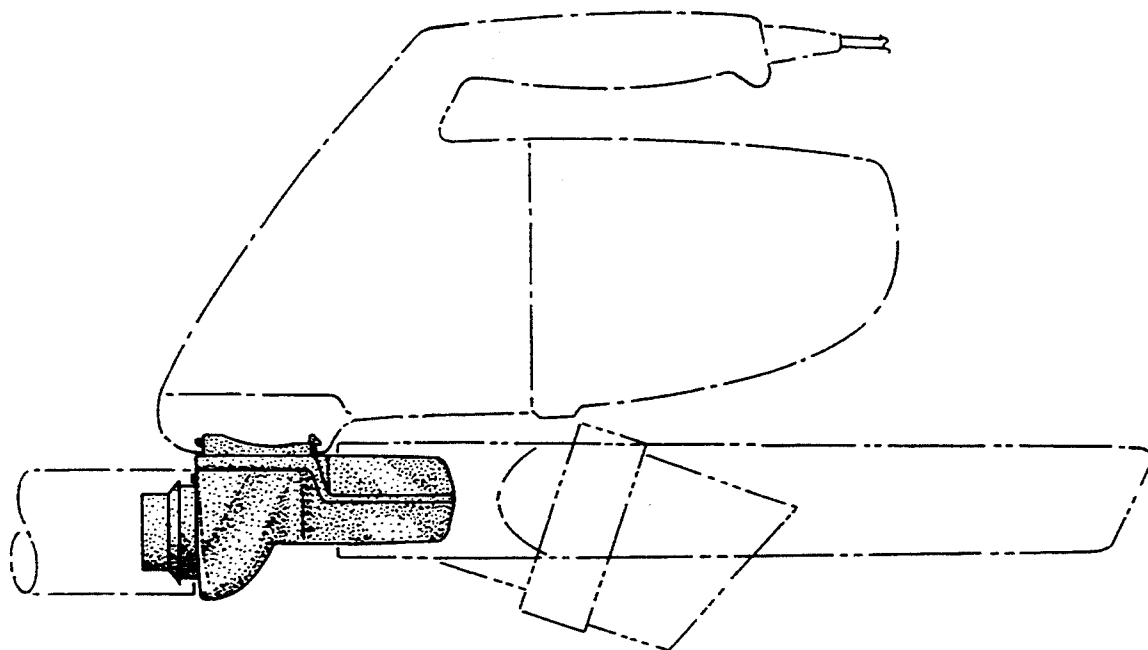

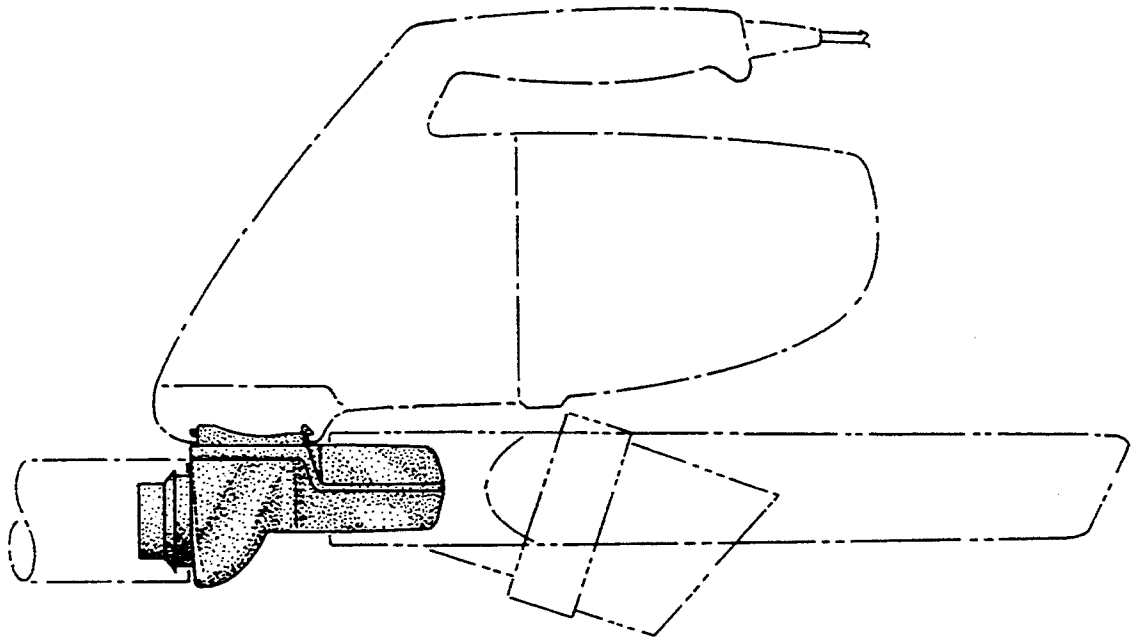

FIG.-1

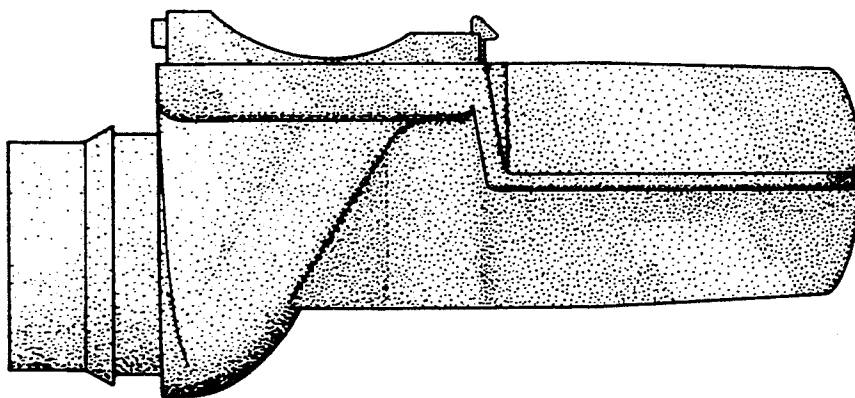

FIG.-2

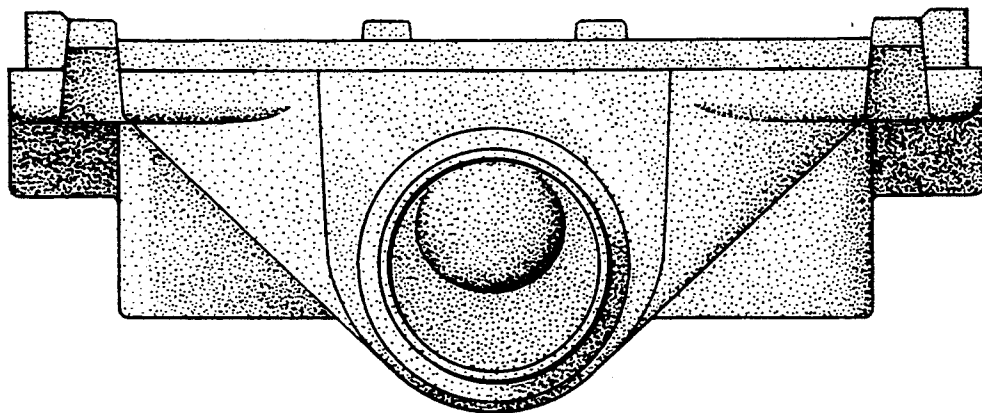

FIG.-3

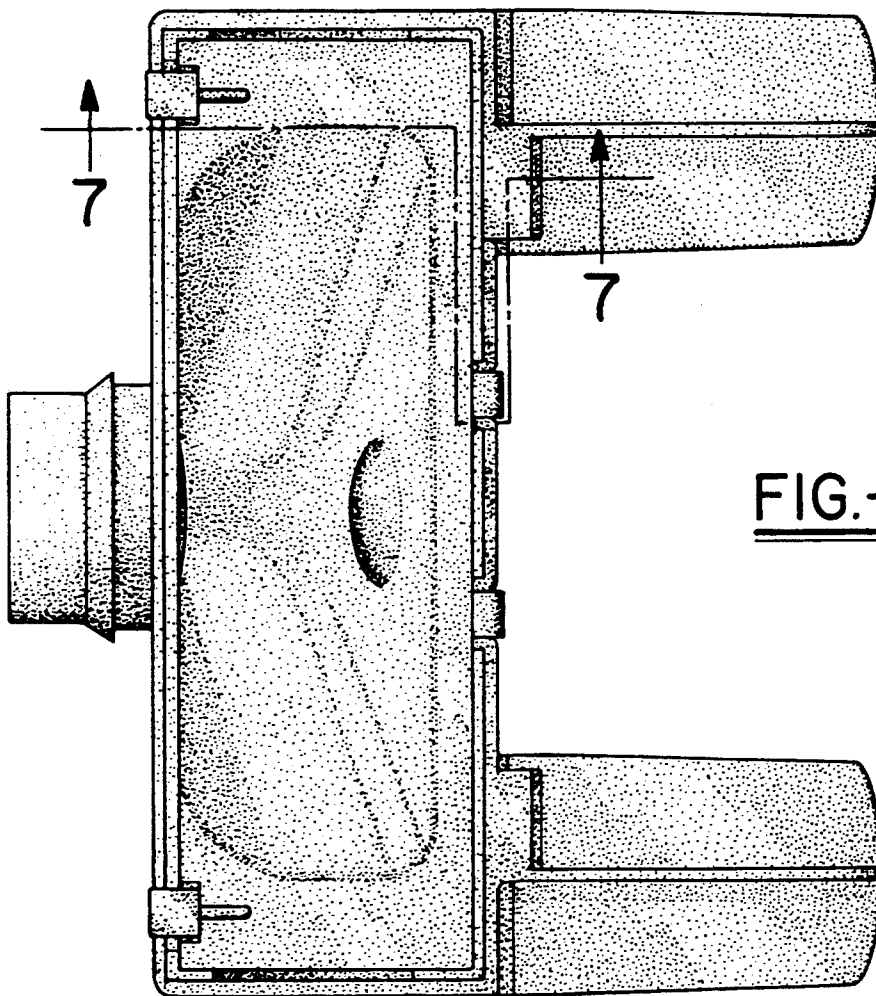

FIG.-4

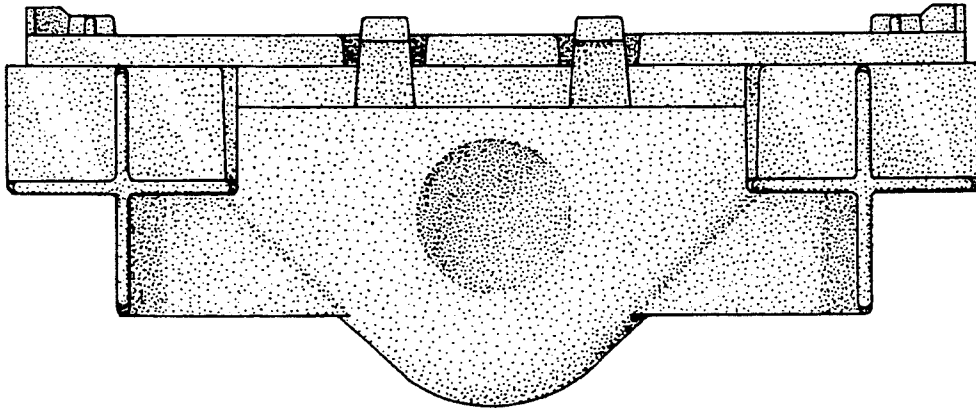

FIG.-5

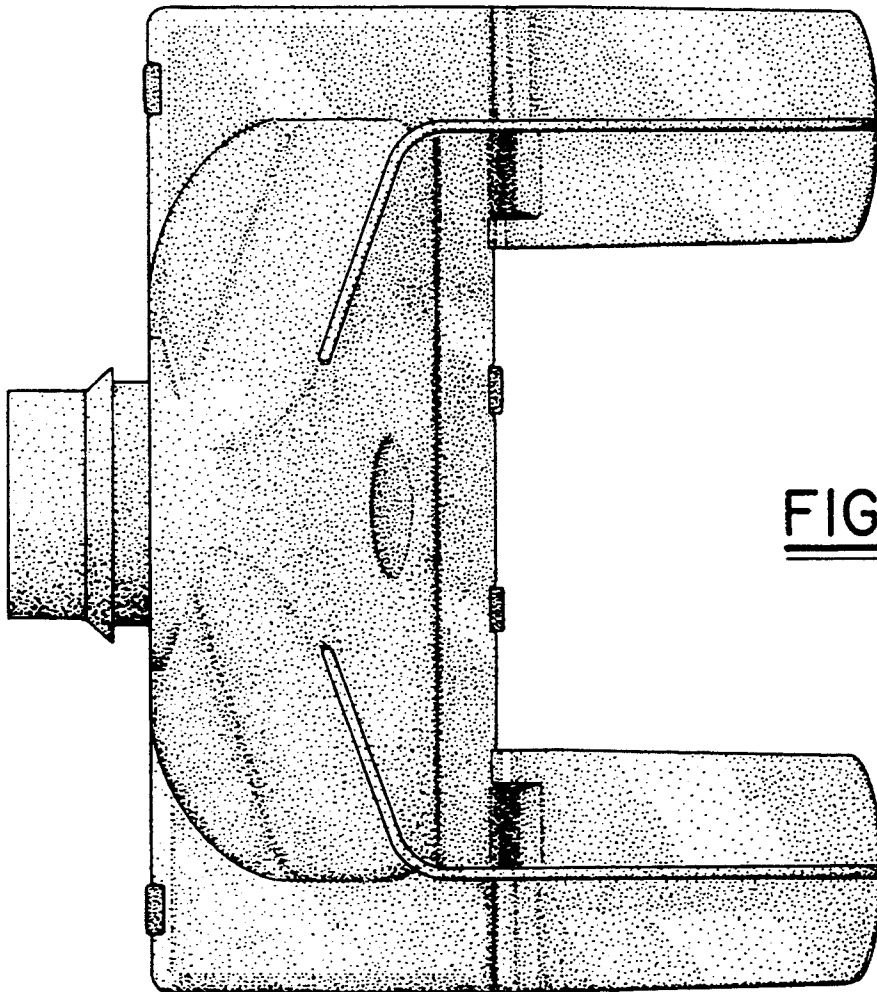

FIG.-6

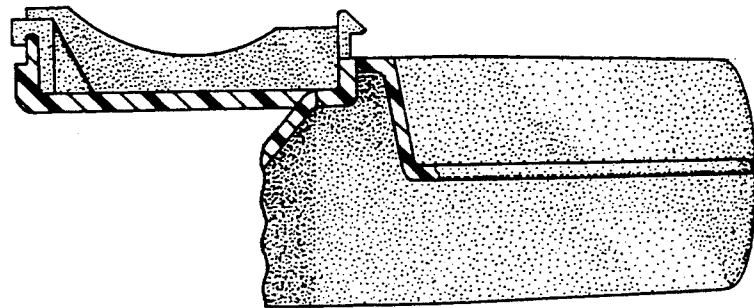

FIG.-7