

(19) World Intellectual Property Organization  
International Bureau



(43) International Publication Date  
27 December 2001 (27.12.2001)

PCT

(10) International Publication Number  
**WO 01/97687 A1**

(51) International Patent Classification<sup>7</sup>: **A61B 5/00**

(21) International Application Number: PCT/US00/17012

(22) International Filing Date: 20 June 2000 (20.06.2000)

(25) Filing Language: English

(26) Publication Language: English

(71) Applicant: **INTELLICARDIA, INC.** [US/US]; 3960  
Broadway, New York, NY 10032 (US).

(72) Inventors: **LEVIN, Howard, R.**; 640 Pomander Walk,  
Teaneck, NJ 07666 (US). **LUNDMARK, David, C.**; 755  
Page Mill Road, Palo Alto, CA 94304-1018 (US).

(74) Agent: **NELSON, Jeffrey, H.**; Nixon & Vanderhye P.C.,  
Suite 800, 1100 North Glebe Road, Arlington, VA 22201-  
4714 (US).

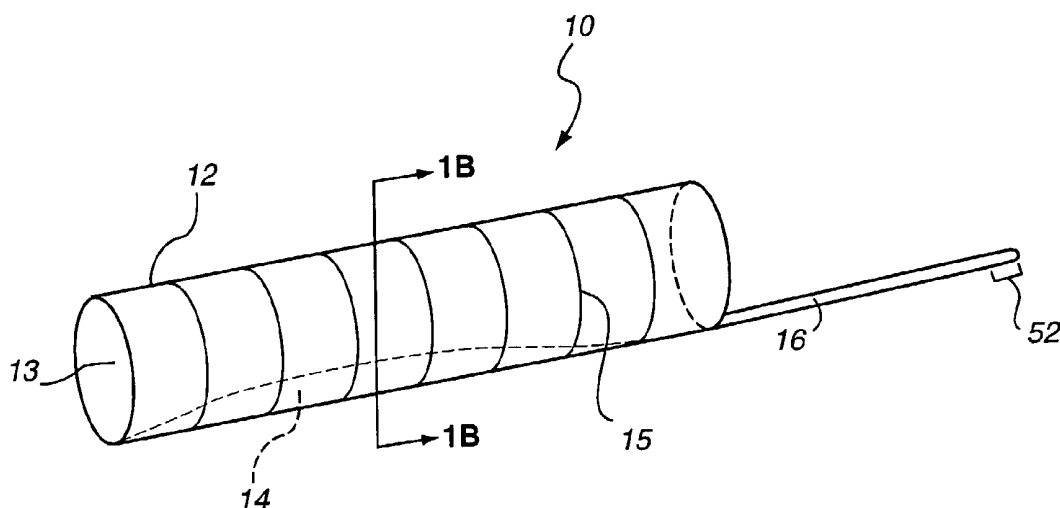
(81) Designated States (*national*): AE, AL, AM, AT, AU, AZ,  
BA, BB, BG, BR, BY, BZ, CA, CH, CN, CR, CU, CZ, DE,  
DK, DM, EE, ES, FI, GB, GD, GE, GH, GM, HR, HU, ID,  
IL, IN, IS, JP, KE, KG, KP, KR, KZ, LC, LK, LR, LS, LT,  
LU, LV, MA, MD, MG, MK, MN, MW, MX, MZ, NO, NZ,  
PL, PT, RO, RU, SD, SE, SG, SI, SK, SL, TJ, TM, TR, TT,  
TZ, UA, UG, UZ, VN, YU, ZA, ZW.

(84) Designated States (*regional*): ARIPO patent (GH, GM,  
KE, LS, MW, MZ, SD, SL, SZ, TZ, UG, ZW), Eurasian  
patent (AM, AZ, BY, KG, KZ, MD, RU, TJ, TM), European  
patent (AT, BE, CH, CY, DE, DK, ES, FI, FR, GB, GR, IE,  
IT, LU, MC, NL, PT, SE), OAPI patent (BF, BJ, CF, CG,  
CI, CM, GA, GN, GW, ML, MR, NE, SN, TD, TG).

Published:  
— with international search report

For two-letter codes and other abbreviations, refer to the "Guidance Notes on Codes and Abbreviations" appearing at the beginning of each regular issue of the PCT Gazette.

(54) Title: INSTRUMENTED STENT



(57) Abstract: This is an implantable device intended generally for sensing tissue parameters within lumens of the body. The device is made up of a stent (12), often radio-opaque, and a sensor (14), coupled to the stent and preferably configured to minimize flow turbulence. The device may comprise various types of sensors, as well as multiple sensors. The device may also comprise a sheet-like member which may partially encapsulate the stent, the sensor, or both.



WO 01/97687 A1

**INSTRUMENTED STENT**TECHNICAL FIELD

The present invention relates to an intravascular stent to maintain vascular patency in humans and animals while providing a construct upon which sensor devices may be implantably mounted.

BACKGROUND ART

Intravascular stents have long been applied to maintain vascular patency. Many intravascular stents are used in conjunction with balloon angioplasty wherein a balloon is inflated to expand a constricted vessel in order to restore proper blood flow. The intravascular stent is then positioned inside the now expanded vessel to ensure the vessel maintains the enlarged diameter.

Widespread use of intravascular stents has lead to the development of safe and reliable procedures for endolumenally positioning and implanting them using relatively noninvasive methods into tissue lumens at various locations of the body. There is a need to provide a physical construct upon which implantable sensors such as oxygen sensors and fluid flow sensors can be mounted adjacent to the flow of fluids in lumens of the body. A number of patents have been found describing various stent designs as well as methods for delivering stents to desired positions within the body. These patents include:

U.S. Pats. Nos. 3,868,956 and 4,503,569, each of which describes methods wherein a stent comprising a temperature responsive device is implanted in a damaged

vessel and thereafter expanded by means of an external heat source.

U.S. Pat. No. 4,553,545, which discloses a method whereby a complex mechanical rotating device and coaxial  
5 cables are employed to increase the diameter of the implanted stent.

U.S. Pat. No. 4,580,568, which describes a stent wherein a single wire forming a closed loop is expanded in a damaged vessel to maintain vascular patency. The  
10 loop of wire is compressed to form a series of straight segments and bends, the bends storing energy in the compressed state. Upon removal of a compression means the stent expands and exhibits a circular configuration.

U.S. Pat. No. 4,649,992, which describes a stent  
15 device in combination with a catheter. The stent is a compression spring retained by a partially inflated balloon and an abutment immediately behind the balloon on the catheter shaft. The spring prosthesis is transported to the desired location and released by totally  
20 evacuating the balloon, thereby allowing the spring prosthesis to expand linearly.

U.S. Pat. No. 4,681,110, which describes a catheter for delivery of a stent comprising woven plastic strands forming a tube which can be compressed radially. The  
25 orientation of the plastic strands provides resilience for the tube to expand from a compressed state.

U.S. Pat. No. 4,768,507, which discloses a catheter comprising an outer cylinder and inner core. The inner core has spiral grooves for holding a coil spring stent.  
30 Pliers are used to facilitate the loading of the coil spring into the grooves. Upon completion of the loading

of the outer cylinder, it is placed over the inner core thereby retaining the coil in the compressed state until the coil is released.

U.S. Pats. Nos. 4,690,684, and 4,720,176, each of which discloses a stent for aligning the ends of the vessel during anastomosis by thermal bonding. The stent comprises an integral solid of biologically compatible material to align the vessel ends together during anastomosis. Upon completion of the anastomosis the stent fully melts into the fluid flowing through the vessel. U.S. Pat. No. 4,770,176 also discloses a method of anastomosing a vessel utilizing the stent described in U.S. Pat. No. 4,690,684.

U.S. Pat. No. 4,878,906, which describes a prosthesis comprising a flexible thin-walled plastic sleeve for repairing damaged vessels. The sleeve has sufficient length to cover the damaged area of the vessel by forming a sealed interface between its outer peripheral ends and the inner peripheral surface of the vessel. A bridge is thereby provided to bypass the damaged area of the vessel.

U.S. Pat. No. 4,830,003, which discloses a cylindrical stent comprising angled wires of biocompatible metal. The angled wires are connected obliquely at alternate ends to form a compressible open ended tube.

U.S. Pat. No. 4,866,062, which discloses a radially expandable coronary stent. The stent comprises a flat expandable wire band which is preformed in a zigzag pattern to provide expansion capability. The band is wound into a cylindrical shape and is inflated by means

of a variable diameter device. The band expands radially into a cylindrical shape with increasing diameter.

U.S. Pat. Nos. 4,800,882, 4,739,762 and 4,733,665, each of which discloses an expandable intraluminal graft.

5 These grafts are made of wire or a thin balled tubular member and may be expanded by an angioplasty balloon associated with a catheter.

U.S. Pat. No. 4,760,849, which discloses a planar blank which may be made into a helical coil spring stent.

10 U.S. Pat. No. 4,665,918, which describes a system and method for implanting a generally tubular prosthesis member having an unobstructed central passageway into a blood vessel. The prosthesis member is positioned in a contracted condition between a delivery catheter and  
15 outer sheath, and expands outwardly in response to the removal of the sheath.

None of the foregoing patents, however, disclose an instrumented stent configured to carry one or more sensors to a lumen of the body while limiting the  
20 disruption of fluids flowing therein.

#### SUMMARY OF THE INVENTION

This invention is an implantable device for placement in a body lumen which generally comprises an expandable stent and a sensor, the sensor being coupled  
25 to the stent. The stent has a compressed delivery state and an expanded implantation state, and is preferably designed to be delivered using a catheter.

Many variations of sensors may be coupled to the stent, including oxygen sensors such as those which  
30 include light emitting and light sensing portions, fluid

flow sensors such as Doppler transducers, pressure sensors such as those based upon piezoelectric crystals or crystalline silicon chips, hematocrit sensors such as those based upon blood conductivity or light emission and  
5 detection, temperature sensors such as thermistors or thermocouples, heart electrical signal sensors such as those designed to monitor electrocardiogram signals using electrodes, biochemical sensors such as those based upon enzymatic biosensors, pH level sensors, and blood  
10 electrolyte sensors.

Multiple sensors may be coupled to the stent. The sensors generally have electrical leads which may be coupled together into a single lead portion which is configured to interface with another module such as a  
15 data acquisition component. The end of the lead portion may be removably encapsulated in a flexible material designed to protect the lead ends from surrounding fluids and tissue before it can be attached to another component. The sensor may be directly interfaced with  
20 nearby body fluids or may be covered, partially or wholly, by materials designed to couple the sensor to the stent, improve fluid dynamics within the lumen of the stent, or protect the sensor from fluid exposure. The sensor may be coupled to the stent using a threadlike  
25 member, adhesive, or at least partial encapsulation by a sheet-like member.

The implantable device may also comprise a sheet-like member coupled to the stent and forming a surface thereon. In one variation, the sheet-like member may  
30 define a sheet lumen through which the majority of flow within the stent lumen is directed. The sheet-like

member may also be configured to minimize flow turbulence around irregular geometries within the stent lumen, such as portions of a sensor which may protrude into the stent lumen.

5           The implantable device may also comprise a geometric modification member at least partially encapsulating said sensor and being configured to minimize flow turbulence in fluids flowing through the stent lumen and body lumen. In one variation, the surface forms a airfoil shape  
10   having a tapered leading portion and a tapered trailing portion. The sheet-like member may also be configured so the device has a relatively constant cross section along an axis parallel to fluid flow within the stent lumen. The sheet-like member may be comprised of a semi-  
15   permeable material such as a polymer, or more specifically, expanded PTFE.

          The device may also comprise a data acquisition system configured to receive signals from the sensor. The data acquisition system may be configured to create  
20   and store records of signals received from the sensor. In one variation, the data acquisition system is implantable and is configured to facilitate transcutaneous monitoring of signals from the sensor.

#### BRIEF DESCRIPTION OF THE DRAWINGS

25           Figures 1A and 1B depict orthogonal and side views, respectively, of a variation of the inventive instrumented stent.

          Figures 2A-2C depict various sensor variations. Figures 2A and 2B depict front and side views,

respectively, of a two-part sensor. Figure 2C depicts a sensor configured to directly access adjacent fluids.

Figures 3A and 3B depict side and sectional views, respectively, of a variation of the inventive  
5 instrumented stent.

Figures 4A and 4B depict side and sectional views, respectively, of a variation of the inventive instrumented stent.

Figures 5A and 5B depict side and sectional views, respectively, of a variation of the inventive  
10 instrumented stent.

Figures 6A and 6B depict side and sectional views, respectively, of a variation of the inventive instrumented stent.

Figures 7A and 7B depict side and sectional views, respectively, of a variation of the inventive instrumented stent having a geometric modification  
15 member.

Figure 8 depicts a side view of a variation of the inventive instrumented stent having a geometric  
20 modification member.

Figure 9 depicts a side view of a variation of the inventive instrumented stent having a geometric modification member.

Figures 10A and 10B depict side and sectional views, respectively, of a variation of the inventive instrumented stent having two geometric modification  
25 members.

Figures 11A and 11B depict side and sectional views, respectively, of a variation of the inventive  
30



instrumented stent having two geometric modification members.

Figure 11C depicts a sectional view of a variation of the inventive instrumented stent having three  
5 geometric modification members.

Figures 12A and 12B depict a side and front view, respectively, of a variation of the inventive instrumented stent having two sensor portions coupled to the outer surface of the stent.

10 Figures 12C and 12D depict a side and front view, respectively, of a variation of the inventive instrumented stent having two sensor portions coupled to the outer surface of the stent.

Figure 13 depicts a side view of a variation of the  
15 inventive device having multiple sensors coupled to the stent.

Figure 14 depicts a side view of a variation of the inventive device having multiple sensors coupled to the stent.

20 Figures 15A-15E depict a method for installing the inventive device.

#### DETAILED DESCRIPTION OF THE INVENTION

An orthogonal view and side view of a variation of the inventive device (10) are depicted in Figures 1A and  
25 1B, respectively. A substantially cylindrical stent (12) is shown, having a collapsible structure which is preferably self-expanding. The stent (12) is shown as it would appear when implanted into a body conduit with its diameter adjusted beyond the collapsed pre-implantation  
30 diameter. The substantially cylindrical expanded shape

defines an inner stent lumen (13) through which fluids may flow when the stent is in an implanted configuration. While the stent shown is made from metal wire (15), a polymeric stent or perforated sleeve having perforations of suitable shape, size, and quantity may be used. Various suitable stents are described, for instance, in U.S. Pat. No. 4,776,337 to Palmaz and PCT US 92/03481 to Hess. These stents may be made from biocompatible implantable metals such as titanium, stainless steel, or Nitinol.

Also shown in Figures 1A and 1B is a sensor (14). The sensor (14) is generally one designed to monitor some changeable aspect of the surrounding tissues or fluids, such as temperature, pressure, oxygen content, fluid pressure, or fluid flow velocity. Preferred sensors include oxygen sensors such as those disclosed in U.S. Pats. Nos. 5,113,862, 5,040,538, and 4,815,469. Such oxygen sensors generally include a light source and a light sensor which must be separated by the fluids which are being measured.

The sensor (14) may also be one which is designed to measure the flow of fluids in an adjacent lumen or pathway. Preferred flow measurement sensors include those disclosed in U.S. Pats. Nos. 5,046,503, 5,740,596, 5,581,144, 5,246,007, 5,174,295, and 5,163,445.

The sensor (14) may also be one which is designed to measure fluid pressure within an adjacent space. Preferred pressure measurement sensors include those wherein a diaphragm is associated with a piezoelectric crystal or a crystalline silicon chip, such as those disclosed in U.S. Pat. No. 5,715,827.

The sensor (14) may also be a temperature sensor. In one variation, the sensor may comprise a thermistor device, while another variation may comprise a thermocouple. Thermistor and thermocouples are well known in the art, and are described in several references including U.S. Pat. No. 5,833,688 which discloses catheter-based sensors which could be incorporated into the inventive device.

The sensor (14) may also be a pH level sensor, such as those which are well known in the art, or a blood electrolyte sensor such as those described in U.S. Pat. No. 4,816,130. Such sensors comprise membranes which directly interface with blood in the desired lumen, and therefore at least a portion of such a sensor must be exposed to the inner lumen defined by the stent. Since these sensors directly interface with blood in the desired lumen, at least a portion of such a sensor (14) is exposed to the inner lumen defined by the stent (12).

The sensor (14) may also be a heart electrical signal sensor, such as an electrocardiogram sensor comprising an implantable electrode. Such electrodes are well known in the art of cardiac pacing and defibrillation, and are generally used in pairs. U.S. Pats. Nos. 5,609,623, 5,554,178, and 5,388,578 disclose electrodes suitable for use in the inventive device.

The sensor (14) may also be a biochemical sensor such as those described in U.S. Pats. Nos. 5,653,862 and 4,935,345. Such sensors may be enzymatic biosensors designed to monitor the effects of certain enzymatic reactions in the body. The biochemical sensors may be implanted for continuous monitoring of glucose and other

chemicals present in the bloodstream. Since these sensors must directly interface with blood in the desired lumen, at least a portion of such a sensor (14) must be exposed to the inner lumen defined by the stent (12).

5 The sensor (14) may also comprise a hematocrit sensor, such as those described in U.S. Pats. Nos. 5,869,971, 5,803,908, 5,385,539, and 5,066,859. Most preferred are hematocrit sensors which comprise a light sensor and light detector and are capable of relatively  
10 noninvasive measurement of blood hematocrit levels. The latter three of the above listed hematocrit sensor references describe such devices. The sensor may also comprise a radiometric measuring device, such as that which is described in the first of the above listed  
15 hematocrit sensor references.

The aforementioned sensors (14) generally involve some type of electronic circuitry to which an electronic lead (16) may be attached for remote monitoring. For this reason, a lead is depicted in Figures 1A, 2B, and  
20 2C. The lead (16) generally comprises at least one conductive material, such as gold, silver, or other known biocompatible conductive metal or alloy, coated with a flexible material such as a polymer, preferably a thin polyurethane coating. The distal end (52) of the lead  
25 (16) is preferably configured to interface with a data monitoring or acquisition device (54) which may be implantable, as is shown in Figure 15E. Specialized leads for such uses are well known in the art of cardiac pacing and defibrillation, and are specifically described  
30 in *A Practical Guide to Cardiac Pacing*, 4<sup>th</sup> Edition, Little Brown & Company, 1994. The distal end (52) of the

lead may also be removably encapsulated by a layer (50) of material, preferably a polymeric material, which is designed to protect the conductive material from surrounding tissues and moisture during implantation, which is described below.

Referring to Figure 1A, the stent (12) may be provided with an exterior partial or full covering of flexible material, or an interior or luminal partial or full covering of flexible material, or both.

Biocompatible polymers such as PTFE or expanded PTFE are suitable materials for such coverings. As is discussed below, the sensor may also have a coating or be partially encapsulated in such material for mechanical fixation to the stent, improved fluid dynamics, improved biocompatibility, or a combined purpose. Uniaxially oriented films having a microstructure of uniaxially oriented fibrils wherein substantially all of the fibrils are oriented parallel to each other may be used. Multiaxially oriented films having microstructures of biaxially or multiaxially oriented fibrils wherein the fibrils are oriented in at least two directions which are substantially perpendicular to each other may also be used. Such materials are commonly used in stents and stent-grafts, and are disclosed in published references such as U.S. Pat. No. 5,810,870.

Multiple sensors (14), for example combinations of several of the aforementioned preferred sensors, may also be coupled to the stent (12) in an embodiment of the invention, depending, of course, upon the geometric constraints of the delivery catheter and body lumen targeted for implantation.

Figures 2A and 2B depict an end view and side view, respectively, of a two-part (18, 20) sensor, such as a oxygen sensor or hematocrit sensor, wherein a light detecting portion (20) detects light which has been emitted from a light emitting portion (18) and passed through blood flowing between the two portions (18, 20). The two portions (18, 20) will generally be mounted upon opposite sides of the stent (12) from each other in an embodiment wherein such a sensor is required. Figure 2C depicts a side view of a sensor such as a biochemical sensor or pH level sensor wherein a portion of the sensor is designed to have direct contact with fluids being monitored. Also shown are leads (16) with lead ends (52) configured for establishing communication between the sensors (18, 20) and a control system (not shown).

With the exception of cardiac monitoring sensors, the sensing devices (14) are preferably configured to monitor characteristics of blood flowing within the lumen of the stent (12). For this reason, and the fact that many of the preferred implantation sites will have approximately circular cross sections, it is preferable to have at least a portion of the sensor located within the lumen of the stent (12) where fluids will be flowing. Locating an inward-projecting element on the inside of a flow-containing lumen presents a fluid dynamics issue which is biologically relevant because excessively turbulent flow is known to contribute to thrombolysis of blood tissues. For this reason, the preferred embodiment comprises a specialized surface geometry for providing a fluid pathway through the lumen of the stent which is designed to promote less turbulent flow. Since the stent

(12) is preferably expandable from a compressed state to an expanded state, as is shown in Figures 15A-15E, sensors (14) must be attached to the stent (12) in some manner which will allow for significant geometric changes by the stent (12).

Figures 3A and 3B depict a side view and a sectional view, respectively, of a variation wherein a sensor (14) attached to a stent (12) with sutures or looped wires (28).

Figures 4A and 4B depict a side view and a sectional view, respectively, of a variation wherein a sensor (14) attached to a stent (12) with an adhesive (30), such as a polymeric adhesive. Many suitable biocompatible adhesives are known for such applications, such as those disclosed in U.S. Pat. No. 5,810,870.

Figures 5A and 5B depict a side view and a sectional view, respectively, of a variation wherein a sensor (14) attached to a stent (12) using a sheet-like member (32) which is partially woven or wrapped around a portion of the sensor (14). The sheet-like member may be comprised of PTFE or expanded PTFE, as is commonly used in the construction of stent grafts, for example as in devices disclosed in U.S. Pat. No. 5,876,432.

Figures 6A and 6B depict a side view and a sectional view, respectively, of a variation wherein a sensor (14) attached to a stent (12) using a sheet-like member (34) which partially encapsulates a portion of the sensor (14). Such a sheet-like member (34) may or may not be porous, and preferably comprises a flexible polymer material such as PTFE, polyurethane, polyethylene, or expanded PTFE. Other known biocompatible means for

attaching a relatively flexible component to one which is relatively stiff may also be used.

Some of the aforementioned sensors (14) may be manufactured in long, narrow, low profile shapes. Other preferred sensors may have more invasive geometries with sharp edges, for example, such as the sensor depicted in Figures 2A-2C. Oxygen and hematocrit sensors may have two separate portions which must be accommodated (18, 20), such as with the sensor depicted in Figure 2A and 2B. The geometries of such sensors are desirably modified for better fluid dynamics thereby avoiding turbulence, dead spots, and flow eddies.

Figures 7A and 7B depict a side view and a sectional view, respectively, of a variation wherein a sensor (14) is coupled to a geometric modification member (36), the geometric modification member (36) having a surface which is designed to minimize flow turbulence. The leading (40) and trailing (42) portions of the geometric modification member may be symmetrically or asymmetrically shaped to produce desired flow effects. In this variation, the sensor (14) has been at least partially encapsulated with a geometric modification member (36) comprising a biocompatible material such as PTFE, polyurethane, polyethylene, or expanded PTFE. The leading and trailing portions in the depicted variation form an airfoil shape with a tapered leading portion (40) and a tapered trailing portion (42).

Figure 8 depicts a side view of a stent (12) with a sensor (14) coupled thereto, the sensor (14) being partially encapsulated by a geometric modification member (36) which leaves an open area (22, 24) for the sensor



(14) to interact with other sensor portions or the fluid flowing in the lumen.

Figure 9 depicts a side view of a device similar to that shown in Figure 8, except for an additional light-transmitting layer (38) which is present in this  
5 embodiment. The light-transmitting layer (38) preferably comprises a lucent polymer such as PETE, which allows for operation of light emitting and detecting sensors such as some of the oxygen and hematocrit sensors mentioned  
10 above.

Figures 10A and 10B depict a side view and a sectional view, respectively, of a variation having a two-part sensor (18, 20) and two geometric modification members (36) having light-transmitting layers (38) at the  
15 light transmission (22) and detection (24) zones.

Figures 11A-11C depict alternative embodiments wherein a mirror (44) is employed to facilitate use of a similar two-part (18, 20) light emission/light detection type sensor. Figures 11A and 11B depict a side view and  
20 a sectional view, respectively, of a variation wherein two portions of the sensor (18, 20) coupled to the stent (12) in an adjacent configuration while the mirror (44) is located across the lumen from them in a configuration wherein light may be emitted from one portion of the  
25 sensor (18) and detected by the other portion (20). Such a configuration may allow for less flow impairment since the mirror (44) may be very low in geometric profile, requiring little geometric modification (35), such as that which may be provided by a thin light-transmitting  
30 layer (38) at least partially encapsulating the mirror (44) as shown in the figure, and the two sensor portions

may be partially encapsulated by the same geometric modification member (36) as shown in the figure.

The variation depicted in partial cross-sectional view in Figure 11C uses a similar mirror (44)  
5 configuration to reflect light from one portion of the sensor (18) to the other (20), and has three separate geometric modification members (35, 36, 37) since all three elements (44, 18, 20) are in different locations around the interior of the stent (12). Such a  
10 configuration is relatively conducive to radial compression, a requirement for delivery to remote locations with a catheter (56).

Figures 12A and 12B depict a side view and a front view, respectively, of a variation of the subject device  
15 wherein a sensor, in this case a two-part sensor (18, 20), is coupled to the outside of the stent (12). The sensor (18, 20) may be coupled to the stent (12) using any of the aforementioned techniques, including suturing, adhesive, weaving, and encapsulation. In the depicted  
20 variation, the sensor portions (18, 20) are partially encapsulated in sheet-like members (35, 36) which do not limit their direct access to fluids within the lumen of the stent (12). Figures 12C and 12D depict a side view and a front view, respectively, of a related variation  
25 wherein the coverings (35, 36) for the sensor portions (18, 20) extend the length of the stent (12) to provide a more uniform external geometry to the construct.

Figure 13 depicts a side view of a stent (12)  
instrumented with several sensors (14, 15, 18, 20), some  
30 of which are configured to have direct access to fluids in the stent lumen (26), and some of which are configured

to have access through a light-transmitting layer (38). The depicted embodiment has two geometry modification members (35, 36), each of which has a trailing portion (42) which exceeds its counterpart leading portion (40) in length. Also shown is a single lead member (16) configured to carry information from all of the sensors (14, 18, 20).

Figure 14 depicts a side view of a stent (12) instrumented with several sensors (14, 18, 20) which are coupled to the outside of the stent (12) and configured to monitor fluids flowing within the lumen of the stent (12). Also shown in Figures 12A, 12C, 13, and 14 are leads (16) configured to place the associated sensors or sensor portions (18, 20) in communication with a control system (not shown).

Figures 15A-15E depict a method for implanting a preferred device. In Figure 15A, a delivery catheter (56) is shown with a compressed instrumented stent (10) being pushed out into a vessel (4) which defines a lumen (58) with lead (16) and specialized lead end (52) trailing behind. Figure 15B shows the instrumented stent (10) expanded against the vessel (4) and deployed from the delivery catheter (56) with lead (16) and lead end (52) trailing behind. Installation of the instrumented stent (10) may be accomplished using one of several known techniques for installing expandable stents, such as direct push-out of the end of a delivery catheter for self-expanding stents using a push wire or structural sleeve, pull-away corset tie lines for self-expanding stents, and balloon expansion catheters for stents which

must be actively expanded into position. The depicted installation employs a push wire (6).

As shown in Figure 15C, a small aperture (60) is created in the tissue wall using known surgical techniques through which a retrieval instrument (48) may be extended to retrieve the lead (16) for the sensors of the instrumented stent. As shown in Figure 15D, the lead (16) is pulled out through the aperture (60) and the aperture is closed using a purse-string suture or other known method for closing apertures in blood vessels around protruding elements. Figures 15D and 15E depict the removable coating being removed from the conductive end (52) of the lead (16) to facilitate electrical connection between the lead end (52) and a data acquisition device (54), which may be part of an integrated implantable system such as an implantable defibrillator. The data acquisition device is preferably configured to receive signal data from the sensor or sensors (14), and transcutaneously transmit it to a monitoring device (55), which may be located on the other side of the skin boundary (8). The data acquisition device (54) may be further configured to store signal data for later retrieval. The data acquisition (54) and monitoring (55) devices may comprise an integrated system. Integrated acquisition, retrieval, and monitoring systems are well known in the art of implantable defibrillators, and are disclosed in various forms by references such as U.S. Pat. No. 5,314,450.

Each of the U.S. patent documents, U.S. patent application documents, foreign patent documents, and scientific reference documents (including texts and

scientific journal articles) referred to in the text of this document is incorporated by reference into this document in its entirety.

Many alterations and modifications may be made by  
5 those of ordinary skill in the art without departing from the spirit and scope of this invention. The illustrated embodiments have been shown only for purposes of clarity. The sensors shown in the various figures, for example, may range in size from much smaller in scale than their  
10 drawn representations, to larger in scale. These examples should not be taken as limiting the invention defined by the following claims, said claims including all equivalents now or later devised.

WHAT IS CLAIMED IS:

1. An implantable device for placement in a body lumen comprising:
  - a. an expandable stent having a compressed delivery state and an expanded implantation state, said stent forming a stent lumen when in said expanded implantation state and being configured to direct fluids flowing within said body lumen through said stent lumen when said expandable endolumenal implant is in said expanded implantation state; and
  - b. a sensor coupled to said expandable stent.
2. The implantable device of claim 1 wherein said sensor is an oxygen sensor.
3. The implantable device of claim 2 wherein said oxygen sensor comprises a light-emitting device and a light-detecting device.
4. The implantable device of claim 1 wherein said sensor is a fluid flow sensor.
5. The implantable device of claim 1 wherein said sensor is a pressure sensor.
6. The implantable device of claim 1 wherein said sensor is a temperature sensor.
7. The implantable device of claim 1 wherein said sensor comprises a heart electrical signal sensor.

8. The implantable device of claim 15 wherein said heart electrical signal sensor comprises an electrocardiogram sensor having an implantable electrode.

9. The implantable device of claim 1 wherein said sensor is a pH level sensor.

10. The implantable device of claim 1 wherein said sensor is a blood electrolyte sensor.

11. The implantable device of claim 1 wherein said sensor comprises a sensor electronic lead, said sensor electronic lead being removably encapsulated in a flexible material and being configured to interface with a data acquisition port of a data acquisition device.

12. The implantable device of claim 1 further comprising a geometry modification member, said geometry modification member at least partially encapsulating said sensor and being configured to minimize flow turbulence in fluids flowing through said stent lumen and said body lumen.

13. The implantable device of claim 1 further comprising a data acquisition system, said data acquisition system being configured to receive signals from said sensor.

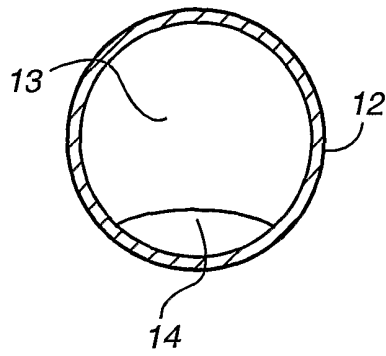
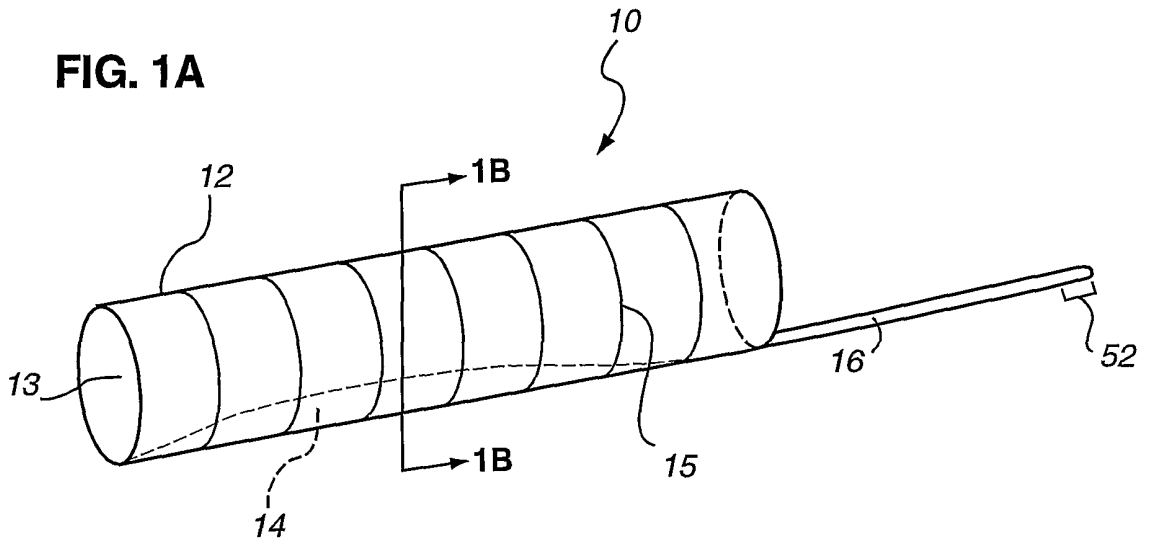
14. The implantable device of claim 13 wherein said data acquisition system is configured to create and store records of signals received from said sensor.

15. The implantable device of claim 13 wherein said data acquisition system is implantable and is configured to facilitate transcutaneous monitoring of signals from said sensor.



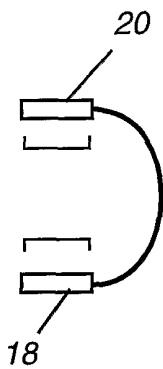
1/7

**FIG. 1A**

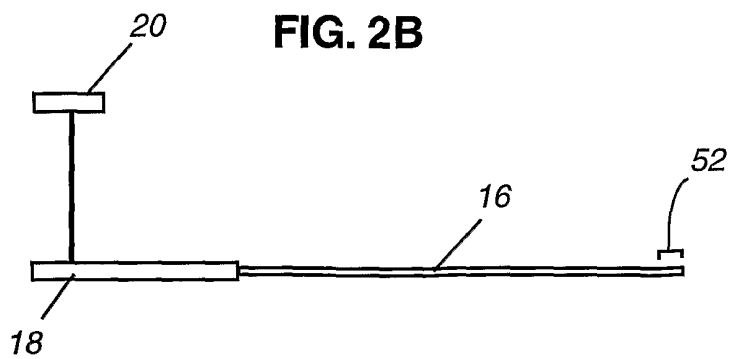


**FIG. 1B**

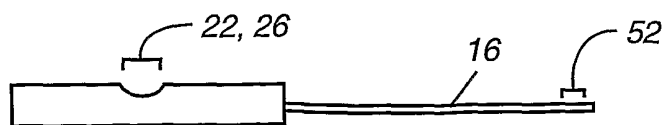
**FIG. 2A**



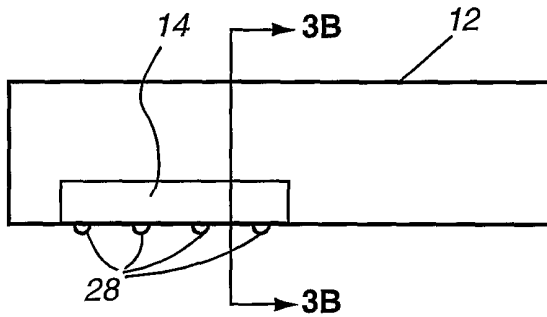
**FIG. 2B**



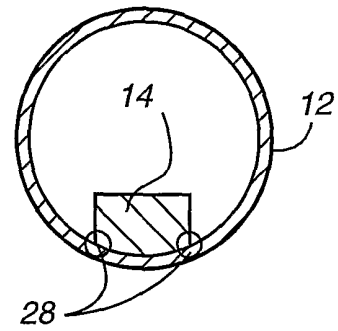
**FIG. 2C**



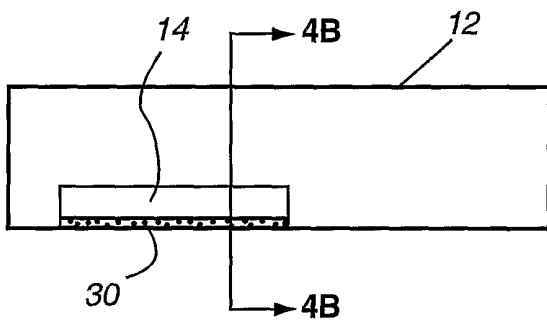
**FIG. 3A**



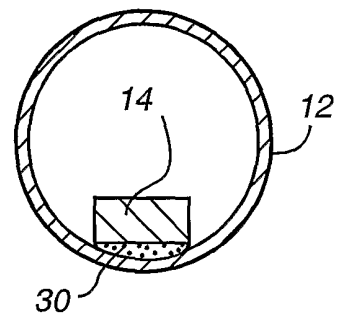
**FIG. 3B**



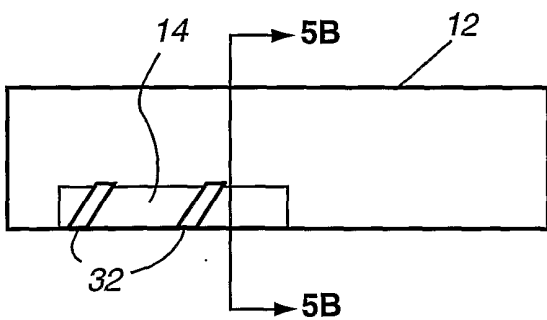
**FIG. 4A**



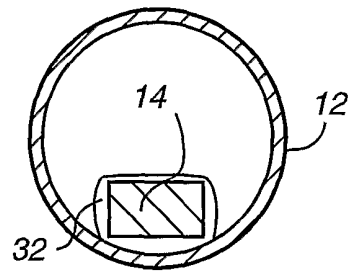
**FIG. 4B**



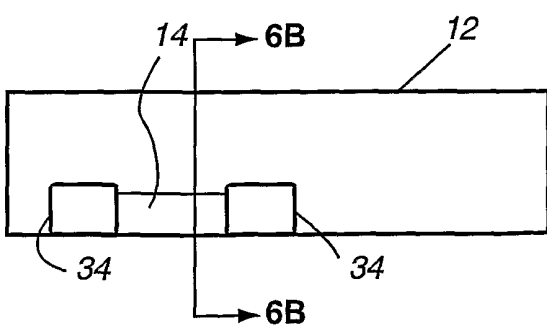
**FIG. 5A**



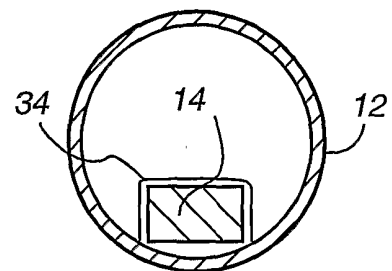
**FIG. 5B**



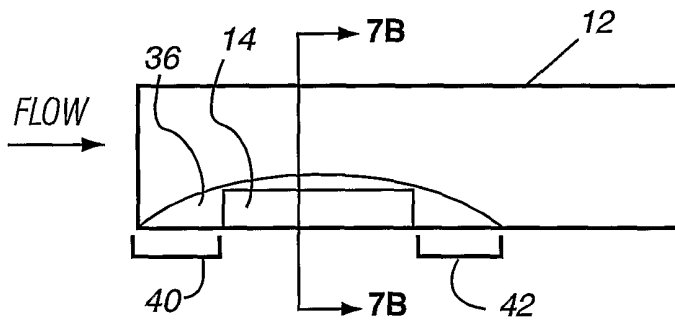
**FIG. 6A**



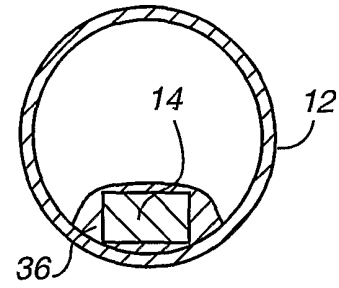
**FIG. 6B**



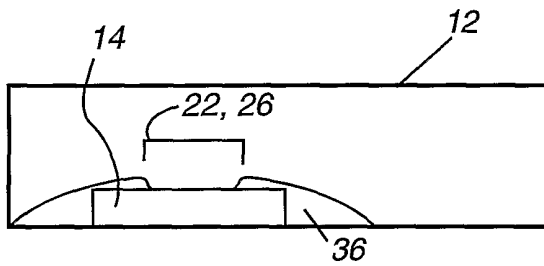
**FIG. 7A**



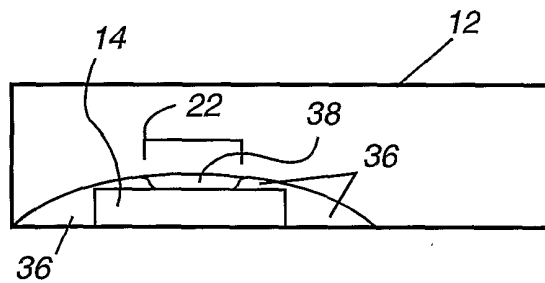
**FIG. 7B**



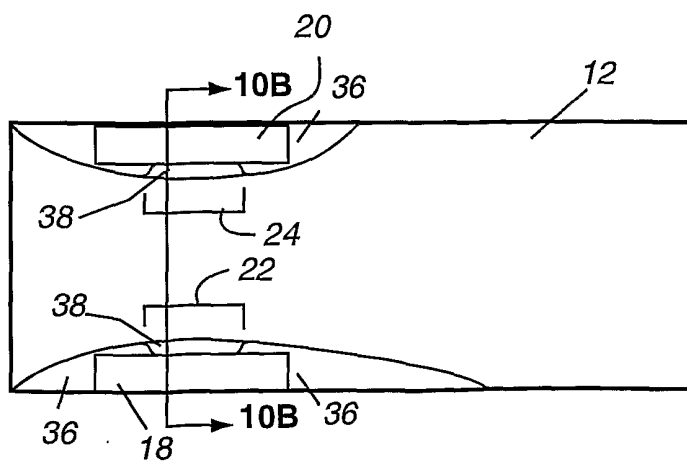
**FIG. 8**



**FIG. 9**



**FIG. 10A**



**FIG. 10B**

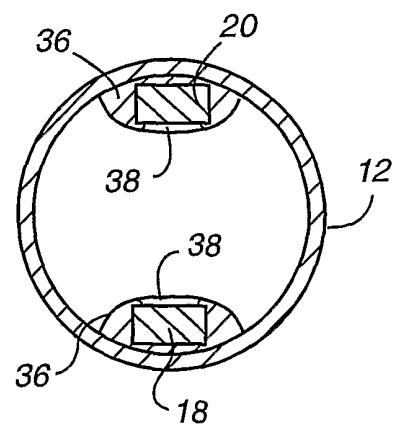


FIG. 11A

4/7

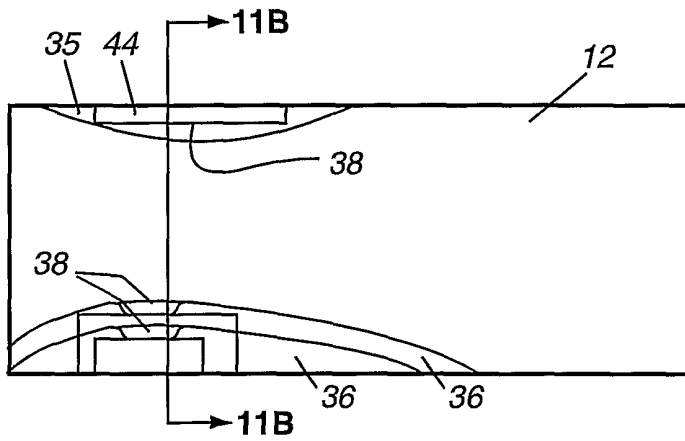


FIG. 11B

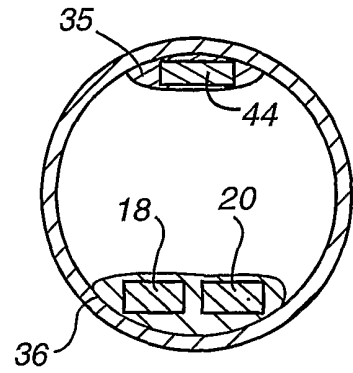


FIG. 11C

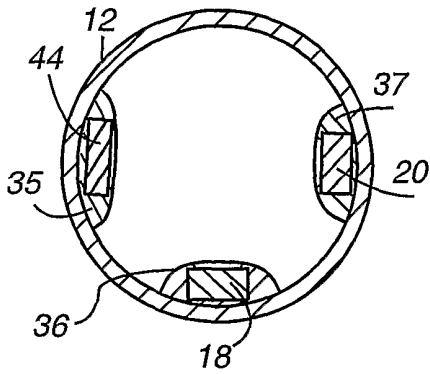


FIG. 12A

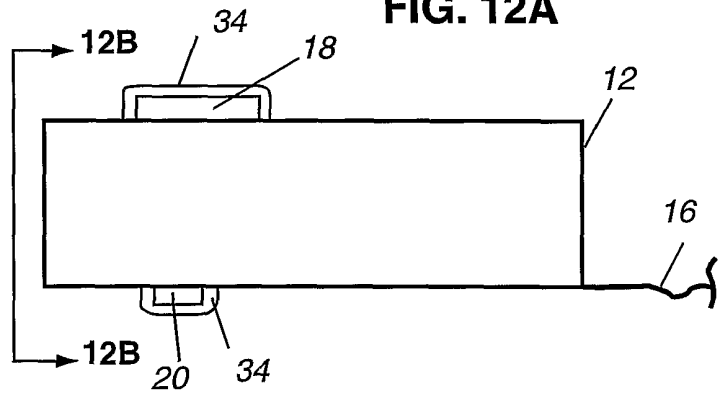


FIG. 12C

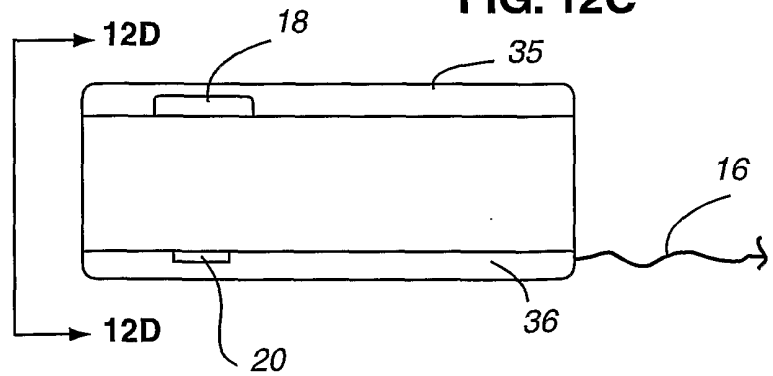


FIG. 12B

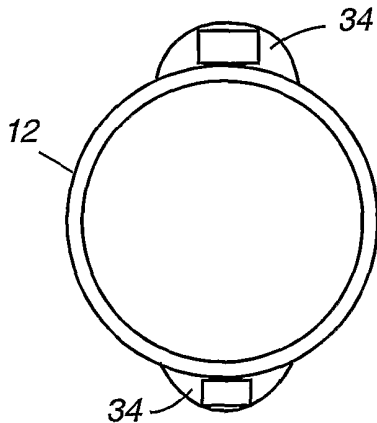
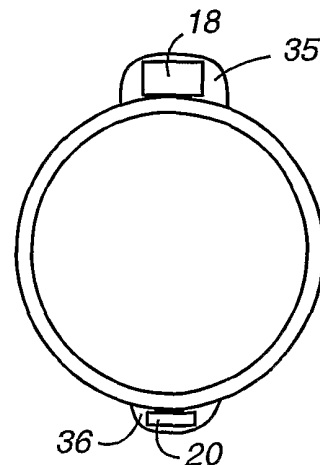
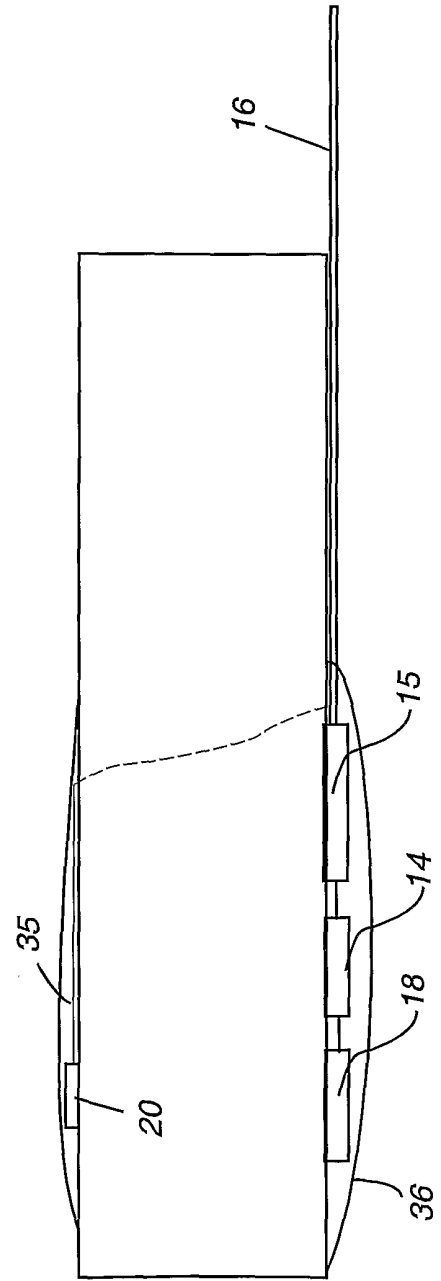
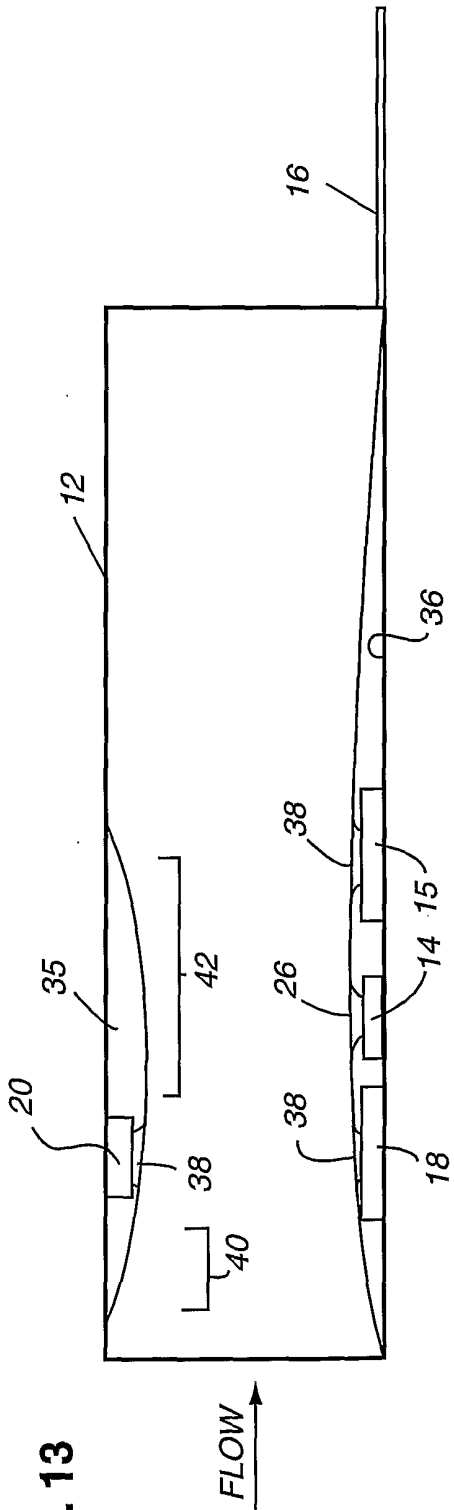


FIG. 12D





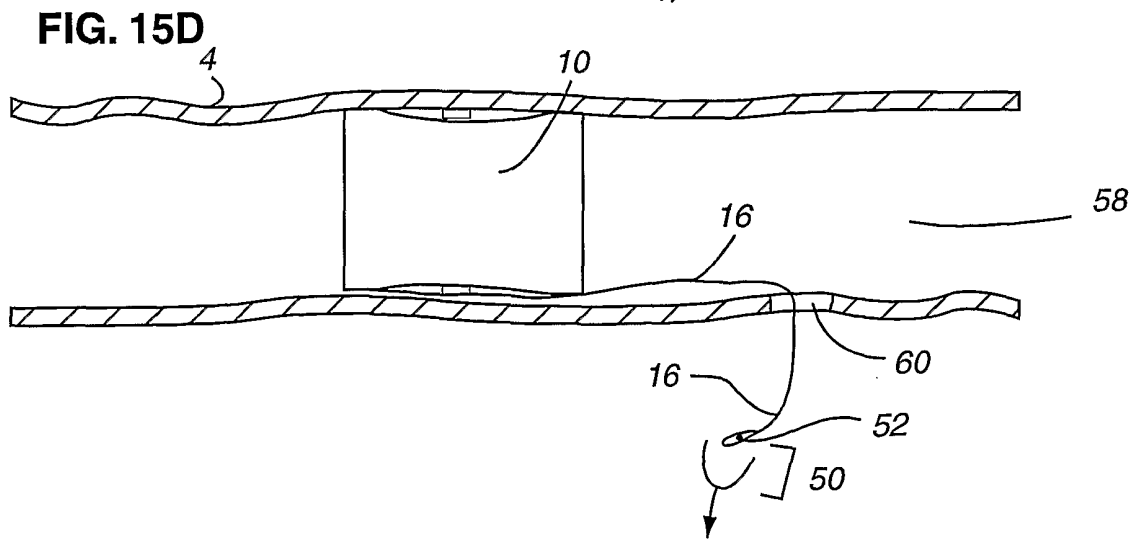
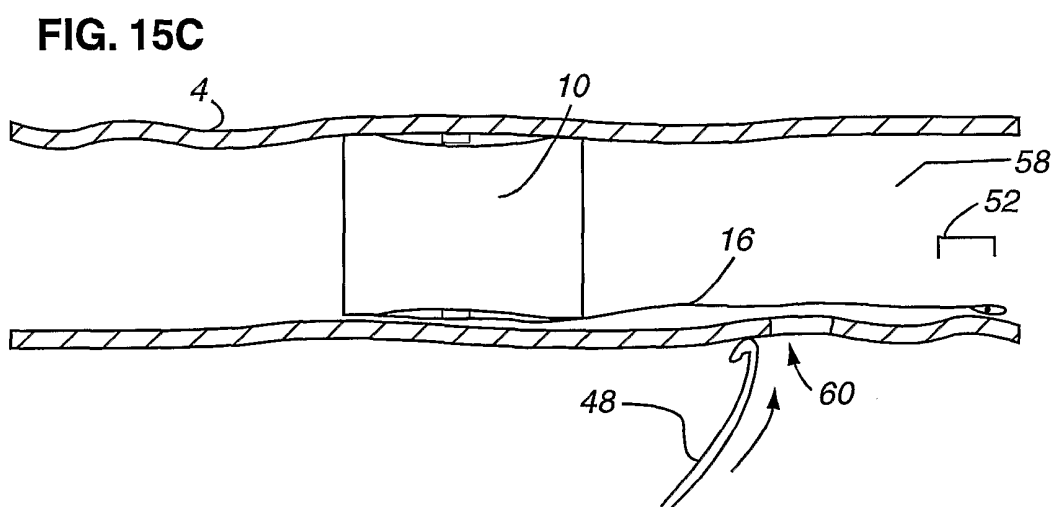
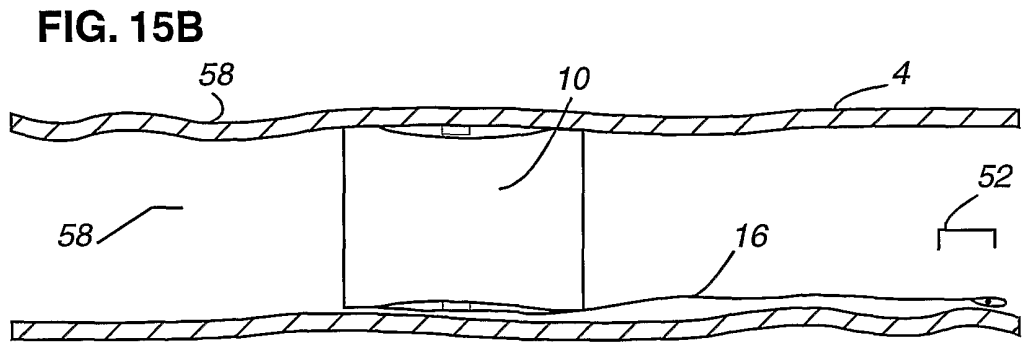
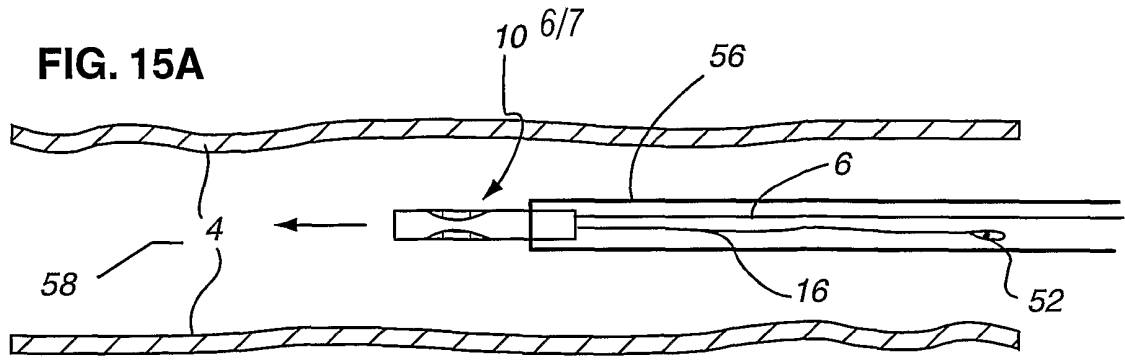
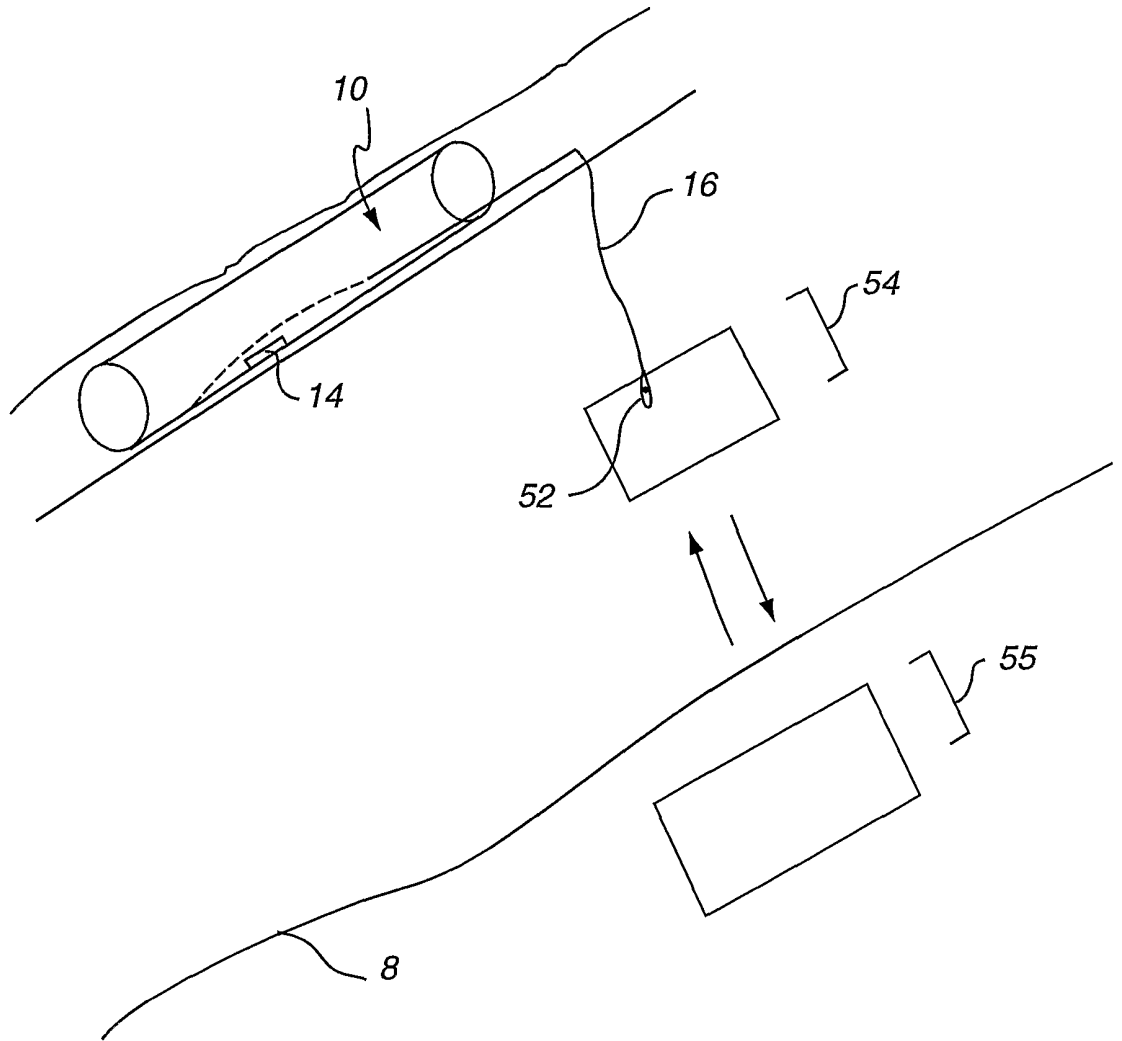


FIG. 15E



# INTERNATIONAL SEARCH REPORT

International Application No  
PCT/US 00/17012

<b>A. CLASSIFICATION OF SUBJECT MATTER</b> IPC 7 A61B5/00				
According to International Patent Classification (IPC) or to both national classification and IPC				
<b>B. FIELDS SEARCHED</b> Minimum documentation searched (classification system followed by classification symbols) IPC 7 A61B A61F				
Documentation searched other than minimum documentation to the extent that such documents are included in the fields searched				
Electronic data base consulted during the international search (name of data base and, where practical, search terms used)  EPO-Internal				
<b>C. DOCUMENTS CONSIDERED TO BE RELEVANT</b>				
Category °	Citation of document, with indication, where appropriate, of the relevant passages	Relevant to claim No.		
X  A  X  A	US 5 411 551 A (WINSTON ET AL.) 2 May 1995 (1995-05-02) column 5, line 67 -column 7, line 20 figures 7-10  ---- US 6 053 873 A (GOVARI ET AL.) 25 April 2000 (2000-04-25) column 10, line 22 - line 48 column 12, line 32 -column 15, line 16 figures 2,4B  ---- -/--	1  11,13  1  2,4-6, 9-11, 13-15		
<input checked="" type="checkbox"/> Further documents are listed in the continuation of box C.				
<input checked="" type="checkbox"/> Patent family members are listed in annex.				
° Special categories of cited documents :				
<table style="width: 100%; border: none;"> <tr> <td style="width: 50%; border: none; vertical-align: top;">                     *A* document defining the general state of the art which is not considered to be of particular relevance                      *E* earlier document but published on or after the international filing date                      *L* document which may throw doubts on priority claim(s) or which is cited to establish the publication date of another citation or other special reason (as specified)                      *O* document referring to an oral disclosure, use, exhibition or other means                      *P* document published prior to the international filing date but later than the priority date claimed                 </td> <td style="width: 50%; border: none; vertical-align: top;">                     *T* later document published after the international filing date or priority date and not in conflict with the application but cited to understand the principle or theory underlying the invention                      *X* document of particular relevance; the claimed invention cannot be considered novel or cannot be considered to involve an inventive step when the document is taken alone                      *Y* document of particular relevance; the claimed invention cannot be considered to involve an inventive step when the document is combined with one or more other such documents, such combination being obvious to a person skilled in the art.                      *Z* document member of the same patent family                 </td> </tr> </table>			*A* document defining the general state of the art which is not considered to be of particular relevance *E* earlier document but published on or after the international filing date *L* document which may throw doubts on priority claim(s) or which is cited to establish the publication date of another citation or other special reason (as specified) *O* document referring to an oral disclosure, use, exhibition or other means *P* document published prior to the international filing date but later than the priority date claimed	*T* later document published after the international filing date or priority date and not in conflict with the application but cited to understand the principle or theory underlying the invention *X* document of particular relevance; the claimed invention cannot be considered novel or cannot be considered to involve an inventive step when the document is taken alone *Y* document of particular relevance; the claimed invention cannot be considered to involve an inventive step when the document is combined with one or more other such documents, such combination being obvious to a person skilled in the art. *Z* document member of the same patent family
*A* document defining the general state of the art which is not considered to be of particular relevance *E* earlier document but published on or after the international filing date *L* document which may throw doubts on priority claim(s) or which is cited to establish the publication date of another citation or other special reason (as specified) *O* document referring to an oral disclosure, use, exhibition or other means *P* document published prior to the international filing date but later than the priority date claimed	*T* later document published after the international filing date or priority date and not in conflict with the application but cited to understand the principle or theory underlying the invention *X* document of particular relevance; the claimed invention cannot be considered novel or cannot be considered to involve an inventive step when the document is taken alone *Y* document of particular relevance; the claimed invention cannot be considered to involve an inventive step when the document is combined with one or more other such documents, such combination being obvious to a person skilled in the art. *Z* document member of the same patent family			
Date of the actual completion of the international search  <p style="text-align: center;">9 March 2001</p>	Date of mailing of the international search report  <p style="text-align: center;">15/03/2001</p>			
Name and mailing address of the ISA European Patent Office, P.B. 5818 Patentlaan 2 NL - 2280 HV Rijswijk Tel. (+31-70) 340-2040, Tx. 31 651 epo nl, Fax: (+31-70) 340-3016	Authorized officer  <p style="text-align: center;">Chen, A</p>			



## INTERNATIONAL SEARCH REPORT

International Application No

PCT/US 00/17012

C.(Continuation) DOCUMENTS CONSIDERED TO BE RELEVANT		
Category °	Citation of document, with indication, where appropriate, of the relevant passages	Relevant to claim No.
X	WO 99 26530 A (CIMOSHOWSKI) 3 June 1999 (1999-06-03) page 8, line 35 -page 9, line 25 page 18, line 11 - line 17 page 22, line 24 -page 23, line 11 page 25, line 20 - line 34 page 28, line 20 -page 31, line 34 figures 7,13-19	1
A	---	4-6,9, 10,12, 13,15
X	WO 00 32092 A (ISHIKAWA ET AL.) 8 June 2000 (2000-06-08) page 7, line 9 -page 10, line 2 page 14, line 10 -page 17, line 14 figures 1-3,6A-8	1
A	---	2-6,9, 12-15
A	US 5 704 352 A (TREMBLAY ET AL.) 6 January 1998 (1998-01-06) column 7, line 18 -column 8, line 15 figure 3	1-6,9, 10,12-14
A	WO 00 30534 A (ISHIKAWA) 2 June 2000 (2000-06-02) page 11, line 15 - line 27 page 16, line 28 -page 20, line 2 page 21, line 11 - line 22 page 26, line 6 - line 21	1-10

## INTERNATIONAL SEARCH REPORT

information on patent family members

International Application No

PCT/US 00/17012

Patent document cited in search report	Publication date	Patent family member(s)	Publication date
US 5411551 A	02-05-1995	US 5306294 A AU 4772693 A CA 2141873 A EP 0653925 A WO 9403128 A US RE35988 E	26-04-1994 03-03-1994 17-02-1994 24-05-1995 17-02-1994 08-12-1998
US 6053873 A	25-04-2000	AU 717916 B AU 5338698 A EP 0904009 A JP 2000507142 T CA 2247943 A WO 9829030 A	06-04-2000 31-07-1998 31-03-1999 13-06-2000 09-07-1998 09-07-1998
WO 9926530 A	03-06-1999	US 5967986 A AU 1363799 A EP 1039831 A	19-10-1999 15-06-1999 04-10-2000
WO 0032092 A	08-06-2000	AU 3790700 A	19-06-2000
US 5704352 A	06-01-1998	NONE	
WO 0030534 A	02-06-2000	AU 2347300 A	13-06-2000