

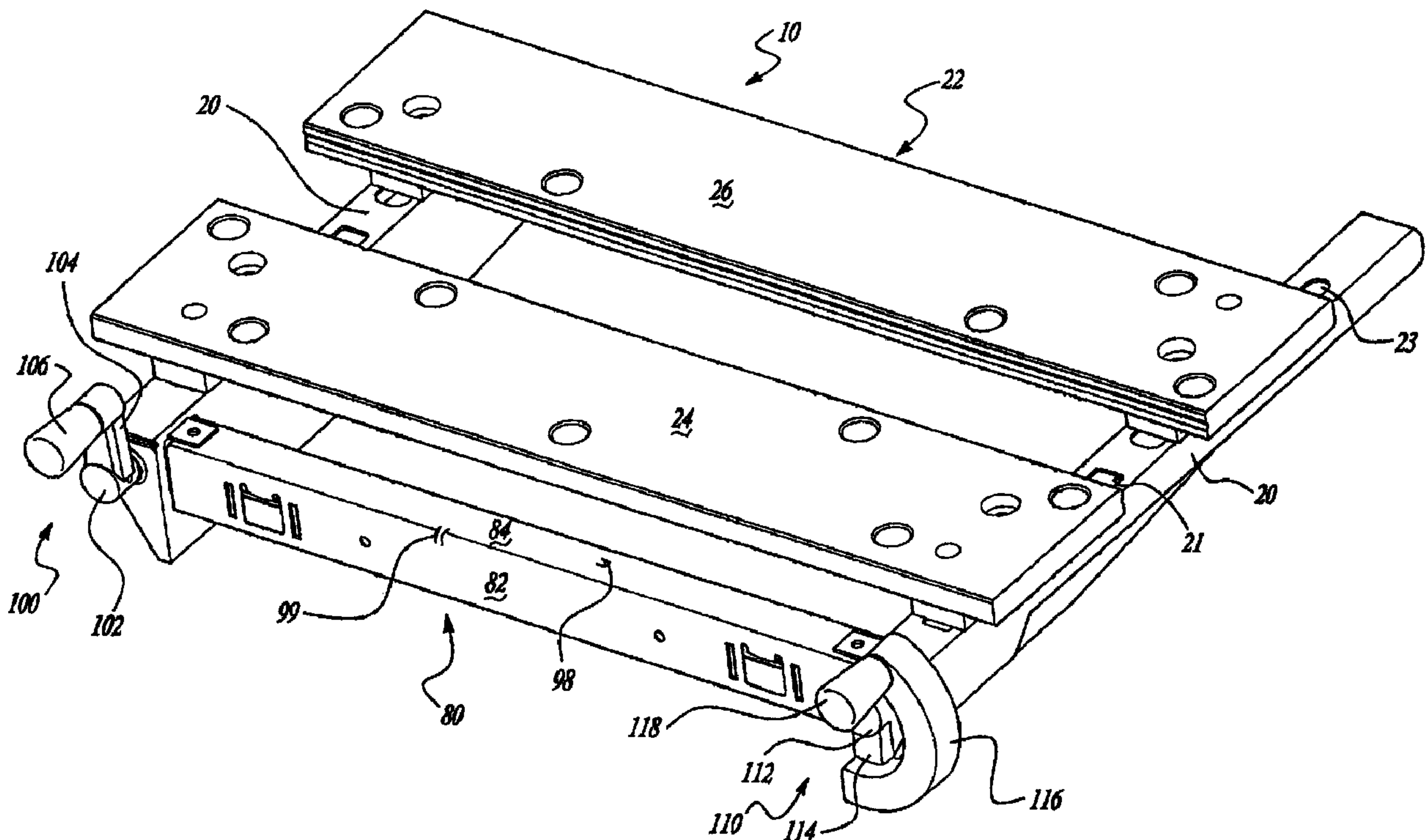

(22) Date de dépôt/Filing Date: 1997/08/06
 (41) Mise à la disp. pub./Open to Public Insp.: 1998/02/12
 (45) Date de délivrance/Issue Date: 2008/07/29
 (62) Demande originale/Original Application: 2 261 714
 (30) Priorité/Priority: 1996/08/07 (US08/692,062)

(51) Cl.Int./Int.Cl. *B25B 1/06* (2006.01),
B25B 1/02 (2006.01), *B25B 1/10* (2006.01),
B25B 1/24 (2006.01), *B25H 1/04* (2006.01),
B25H 1/14 (2006.01)
 (72) Inventeurs/Inventors:
 FORTIN, MARC A., CA;
 HUNTER, MURRAY D., CA
 (73) Propriétaire/Owner:
 BLACK & DECKER INC., US
 (74) Agent: GOWLING LAFLEUR HENDERSON LLP

(54) Titre : POIGNEE TOURNANTE POUR ETABLI
 (54) Title: ROTARY HANDLE FOR A WORK BENCH



(57) Abrégé/Abstract:

A work bench includes a frame, a bench surface on the frame with the bench surface including at least two members, one of which is movable along the frame for clamping a workpiece between the members. A mechanism for moving the member includes two screws coupled with the members. The two screws are spaced with the member for moving the member upon rotation of the screws. A sprocket is coupled with each of the screws. A transmission belt or chain is coupled with the sprockets. At least one handle is coupled with one of the screws to rotate the screws. At least one clutch is coupled with the at least one screw to limit clamping pressure on the workpiece. Also, a guard may be present which covers the transmission belt or chain.

Abstract

5 A work bench includes a frame, a bench surface on the frame with the bench
surface including at least two members, one of which is movable along the frame for
clamping a workpiece between the members. A mechanism for moving the member
includes two screws coupled with the members. The two screws are spaced with the
member for moving the member upon rotation of the screws. A sprocket is coupled with
10 each of the screws. A transmission belt or chain is coupled with the sprockets. At least
one handle is coupled with one of the screws to rotate the screws. At least one clutch is
coupled with the at least one screw to limit clamping pressure on the workpiece. Also, a
guard may be present which covers the transmission belt or chain.

ROTARY HANDLE FOR A WORK BENCH

This is a divisional application of Canadian Patent Application 2,261,714 filed August 6, 1997.

5

Field of the Invention

The invention relates to portable work benches or tables which include an integral clamping table or vise. More particularly, the present invention relates to a work table with a clamping table or vise where the vise may be operated with one hand.

10

Background of the Invention

Carpenters, woodworkers and handymen which work with wood as well as other materials, often need a work bench or table which may be utilized to hold workpieces. Ordinarily, these work benches include a vise which clamps portions of the table top together to secure the workpiece on the table. One such device is that of the assignee of the present invention which is sold under the WORKMATE trademark. These tables are versatile, provide for secure clamping, are compact and are convertible to dual height positions.

The work bench ordinarily includes two vise screws with handles on each one. The vise screws, via the handles, are operated by the user with the user using both hands. While a user may utilize one hand, the user must rotate both handles in order to clamp a workpiece between the clamping table members. Accordingly, it is desirable to utilize one hand to crank both of the vise screws so that clamping of the workpiece may be accomplished by the user using only one hand. By enabling cranking of the vise to clamp the workpiece with one hand, the user is capable of holding the workpiece in place with his other hand. Also, it is desirable that the vise clamp irregular objects while turning the vise screws with one hand.

Summary of the Invention

The present invention is typically employed in a work bench including a frame; a table surface on the frame, with the table surface including at least two members; one of which is movably coupled with the frame to enable clamping of a workpiece between the two table surface members. A drive mechanism moves the table members with respect to one another. The drive mechanism includes two screws coupled with one of

the members. The two screws are spaced from one another to move the table member upon rotation of the screws. A sprocket is coupled with each screw. A transmission belt or chain is coupled with the sprocket to drive the screws together. At least one handle is coupled with one of the screws to rotate the screws. At least one clutch is coupled with at least one screw to limit clamping pressures on the workpiece. The clutch enables rotation of one screw with respect to the other screw so that irregular workpieces may be clamped between the table members and clamping of the workpiece may be accomplished by rotation of the handle by one hand of the operator.

In accordance with the invention of the present divisional, there is provided a handle for operating a movable work bench comprising: a hub, a straight portion extending from said hub, said straight portion having two ends, one end extending from said hub, a substantially circular curved portion extending from the second end of said straight portion, said curved portion having two ends, one end continuous with said second end of said straight portion, said second end of said curved portion being a free end, and when viewed in plan, said curved portion defining an arc, wherein said free end approaches an axis through said straight portion, and a knob extending from said curved portion for enabling rotating of said handle.

In preferred forms of the invention, the curved portion has a truncated U-shape with one end coupled with the straight portion and the knob extending from the other end. The hub has a desired height, as well does the straight portion, which is less than the height of the hub. Also, the curved portion has a height greater than the hub. Also, one end of the curved portion and a side of the straight portion are continuous forming a planar side portion of the handle. A connecting member extends between the hub, straight and curved portions, and is unitary with the three. The handle is ordinarily molded from a plastic material.

Additional features of the invention will be apparent from the detailed description of the preferred embodiment, and the appended claims and accompanying drawings, or may be learned by practice of the invention.

30 Brief Description of the Drawings

The accompanying drawings, which are incorporated in and constitute a part of the specification, illustrate one embodiment of the present invention and together, with the description, serve to explain the principles of the invention. In the drawings, the same reference numerals indicate the same parts.

Figure 1 is a perspective view of a work bench top in accordance with the present invention.

Figure 2 is a side elevation view of the work bench with the top of Figure 1.

5 Figure 3 is an exploded perspective view of Figure 1.

Figure 4 is a cross-section view of Figure 1 along line 4-4 thereof.

Figure 5 is a perspective partially in cross-section view of a portion of the transmission drive of the present invention.

Figure 6 is an enlarged perspective view of a portion of the drive.

Figure 7 is a perspective view of the handle without the knob in accordance with
5 the present invention.

Figure 8 is a cross-section view of Figure 7 along line 8-8 thereof.

Figure 9 is a cross-section view of Figure 7 along line 9-9 thereof.

Figure 10 is an enlarged cross-section view of Figure 1 along line 10-10 thereof.

10 Detailed Description of the Preferred Embodiment

The preferred embodiment of the present invention is a work bench which is identified with the reference numeral 10. The work bench includes a frame structure 12 which includes a base 14, four foldable legs 16, two upright H supports 18 which extend from the base 16, and brackets 20 at the other end of the supports 18. The work bench
15 22 is generally formed from two members 24 and 26 which are coupled with the brackets 20.

The brackets 20 are hollow and include elongated slots 21 which enable movement of the front table 24 with respect to the brackets 20. Also, the brackets include apertures 23 to enable the second table portion 26 to be stationarily locked onto
20 the brackets 20. An additional slot 25 is formed in the side of the brackets 20 to enable the belt 56 to pass into the brackets 20 and be coupled with the sprockets 50.

Two screws 30 are positioned within the brackets 20. The screws include a threaded portion 32 which includes a threaded pivot nut 34 which in turn, via a block 36, is coupled with the front moving member 24 of the work bench 22. Also, the screws
25 30 includes a smooth shank portion 38 which includes a portion which extends out beyond the bracket 20 as seen in Figure 1. The smooth shank portion 38 includes a stop 40 as well as apertures 44 and 46.

Sprockets 50 are slidably positioned onto the smooth shank portion 38 of the screws 30. The sprocket 50, as shown, has projecting members 52 which extend into
30 apertures 54 of the belt 56. However, if a chain is used, the projections may be substituted for recesses or the like. The sprocket 50 includes a hub 58 which includes slots or detents 60. The slots 60 are adapted to couple with a detent pin 62 which passes through aperture 44 of the screw 30.

A helical spring 64 is positioned on the smooth shank portion 38 abutting the stop 40 and the sprocket 50. The spring 64 along with the detent pin 62, sprocket 50 and sprocket slots 60 act as a clutch which limits the pressure which can be applied onto the workpiece. The slot or detent 60 in the sprocket enables transmission of light torques
5 necessary to overcome friction to move the first member 24 providing one hand operation. At high clamping torques, the pin 62 disengages from the sprocket detent or slot 60 and compresses the clutch spring 64. When unclamping the workpiece, the clutch automatically engages the pin 62 via the sprocket detent 60 to once again allow one handed operation. The clutch 70 could be incorporated on both screws or a single
10 clutch may be provided. In the case of a single clutch, the other sprocket will be securely pinned to the vise screw. Preferably, each of the screws 30 includes a clutch 70 as described above.

A guard 80 is positioned over the transmission belt or chain 56. The guard 80 includes a first wall 82 and at least one second wall 84, preferably two, which are
15 perpendicular to the first wall 82 forming an overall U-shape and define a channel 85. The guard 80 includes two guides 86 stamped in and cut out of the first wall 82. The guides 86 extend substantially perpendicular to the first wall 80 into the channel 85. The guides 86 are substantially parallel with the second wall 82 and apply tension on the leading 55 side of the belt 56. The guides 86 help to tension the belt or chain as it moves
20 during rotation of the screws 30. Also, the guides 86 extend from the wall 82 transverse to the direction of travel of the belt 56. The guard 80 spans the length of the belt 56 and is secured with the brackets 22 which, in turn, provides additional stability for the frame 12.

Two embossed alignment members 90, 92 sandwich the guide 86. The alignment
25 members 90, 92 are stamped into the first wall 82 of the guard 80. The alignment members 90, 92 help to maintain the belt 56 or chain onto the sprockets 50 during the clamping modes.

A biasing member 96 is secured to the second wall 82 to automatically adjust for changes in belt length and to take up slack in the belt 56. The biasing member 96 is a
30 helical spring which is secured on cut-outs 98, 99 in the guard 80. The spring 96 always provides for positive belt 56 or chain tension. The spring 96 is positioned under the belt 56 and tensions both the leading 55 and trailing 57 sides of the belt 56.

Each screw includes a handle 100 and 110. The handle 100 includes a hub 102, a handle arm 104 and a knob 106. The handle 110 includes a hub 112, a straight portion

114, a curved portion 116 and a knob 118. The hub 112 has a desired height which is larger than the straight portion 114, but less than the curved portion 116. The curved portion 116 has an overall truncated U-shape. Also, a connecting member 120 extends between the hub 112, straight portion 114, and curved portion 116. The handle 110
5 provides a visual indication to the user that the work bench clamping system may be rotated with one hand. Also, the hub 112 includes an aperture 122 which enables a pin 124 to pass there-through to secure the handle on the screw 30 through the aperture 46. Likewise, the handle 100 includes an aperture and a pin to secure it on the screw 30.

The work bench vise of the present invention is ordinarily operated as follows.
10 One of the handles 100, 110 is rotated which, in turn, rotates either one of the screws 30. The rotation of the screw 30 rotates the sprocket 50 and via belt 56 rotates the other screw 30 via its sprocket 50. Thus, both of the screws 30 rotate at the same time, ordinarily, synchronously. As the user is utilizing one hand to rotate both screws 50, the user can use his other hand to hold the workpiece in between the two table members 24,
15 26. As the table members 24, 26 contact the workpiece, and especially if the workpiece has an irregular shape, the front table member 24 will contact the workpiece and the sprocket 50 will compress against the spring 64 and move away from the pin 62, thus engaging the clutch 70. If an irregular shaped workpiece is between the table portions, then one of the screws 30 will not rotate due to the clutching effect while the other will
20 continue to rotate to clamp on the irregular shape of the workpiece. Once the workpiece is initially clamped and not over tightened, the individual screws can be shored up to give a firm grip onto the workpiece.

While the above detailed description describes the preferred embodiment of the present invention, the invention is susceptible to modification, variation, and alteration
25 without deviating from the scope and fair meaning of the subjoined claims.

Claims

1. A handle for operating a movable work bench comprising: a hub, a straight portion extending from said hub, said straight portion having two ends, one end
5 extending from said hub, a substantially circular curved portion extending from the second end of said straight portion, said curved portion having two ends, one end continuous with said second end of said straight portion, said second end of said curved portion being a free end, and when viewed in plan, said curved portion defining an arc, wherein said free end approaches an axis through said straight portion, and a knob
10 extending from said curved portion for enabling rotating of said handle.
2. The handle according to claim 1, wherein said curved portion has a truncated U-shape with one end coupled with said straight portion and said knob extends from the other end of said curved portion.
15
3. The handle according to claim 2, wherein said hub has a first desired height, said straight portion has a second height less than said hub and said curved portion having a third height greater than said hub.
- 20 4. The handle according to claim 3, wherein in an end of said curved portion and a side of said straight portion are continuous forming a planar portion.
5. The handle according to claim 4, wherein a connecting member extended from said hub and is unitary with said straight and curved portions.
25
6. The handle according to claim 5, wherein said handle is an injection molded plastic material.

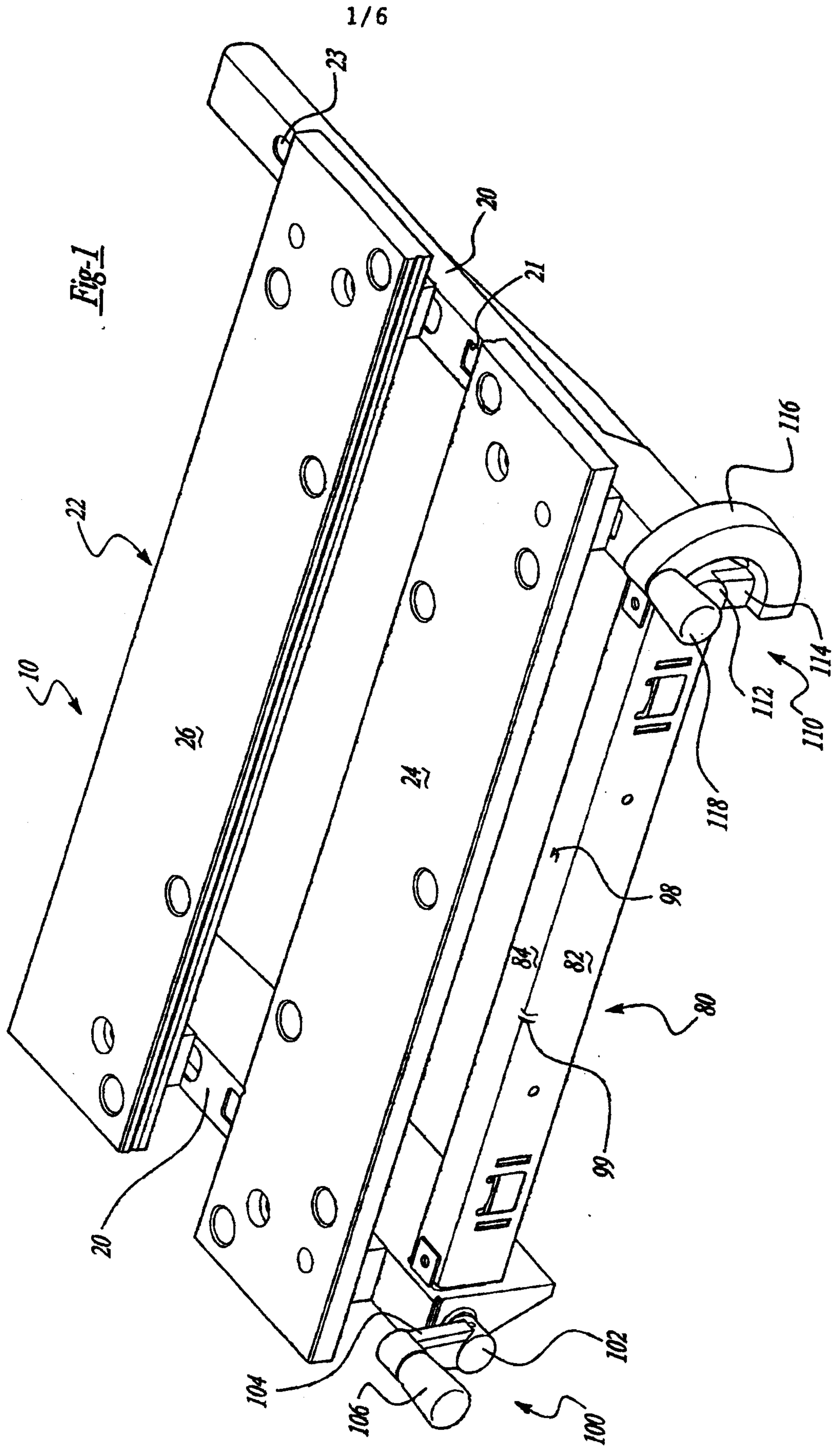

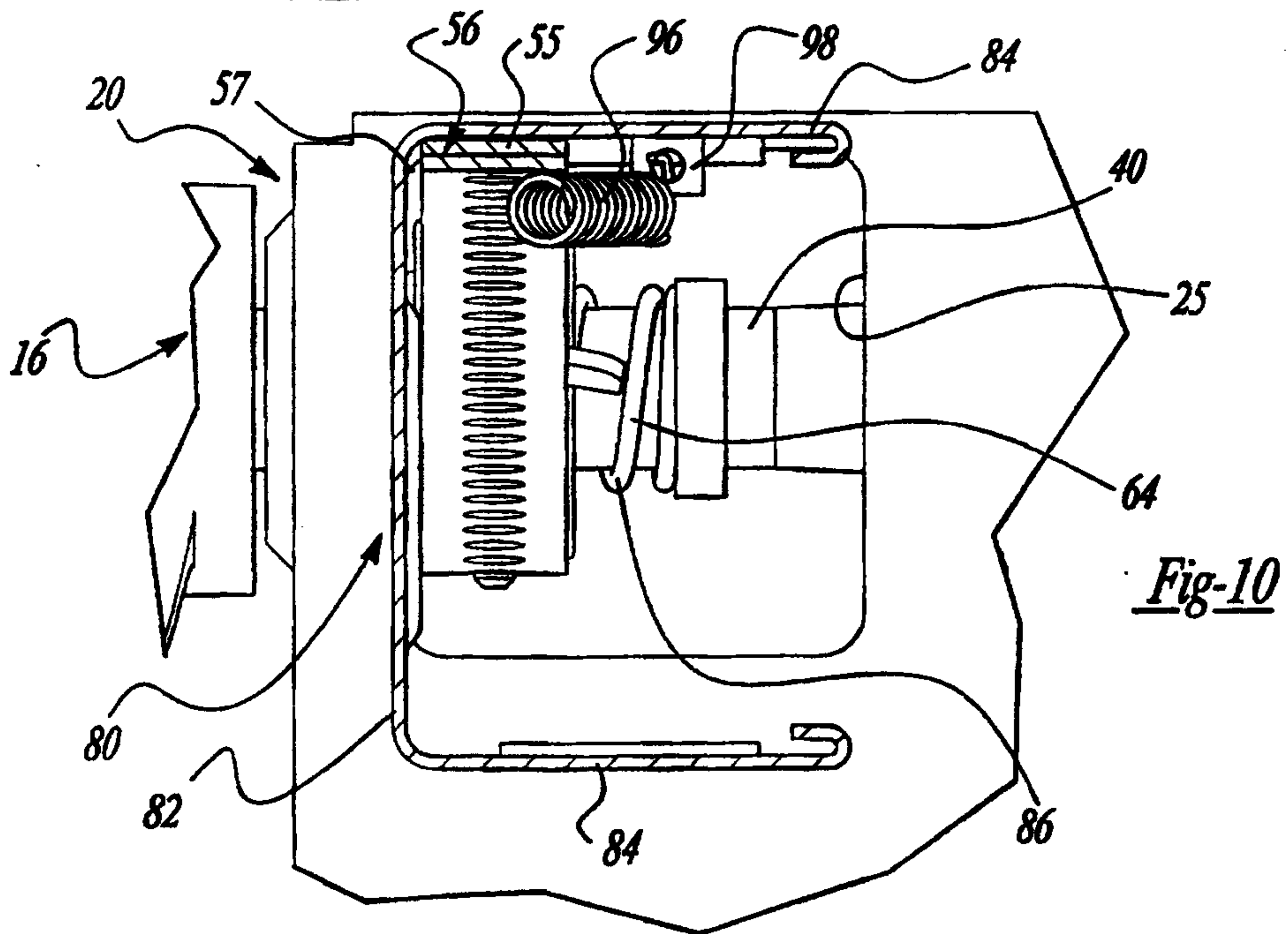
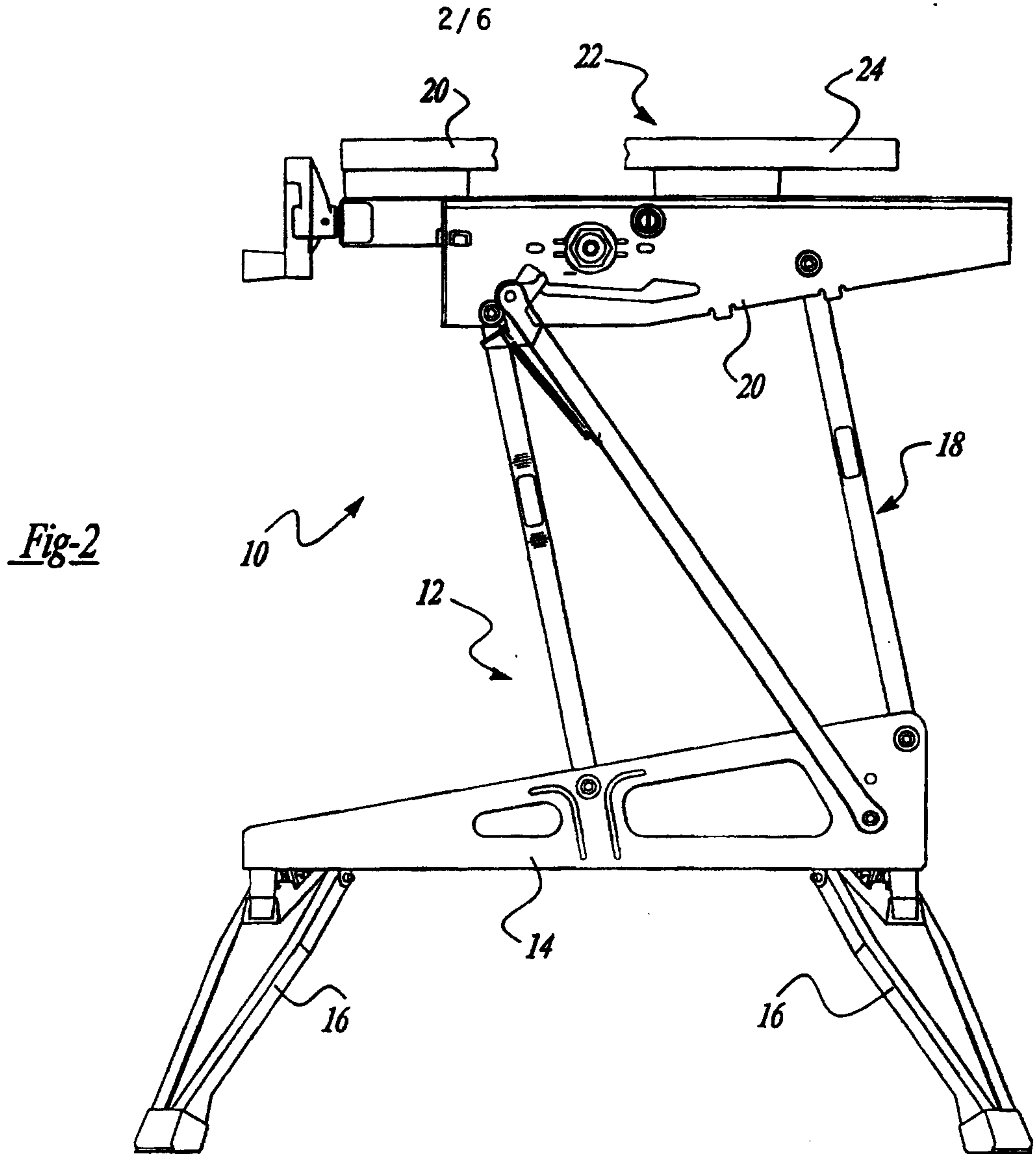

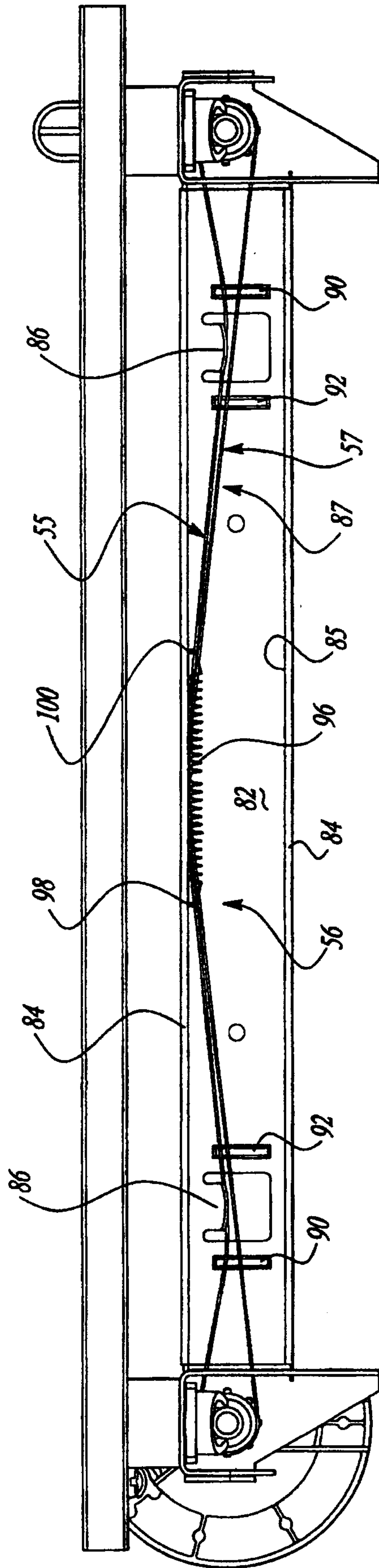

Fig-4

5 / 6

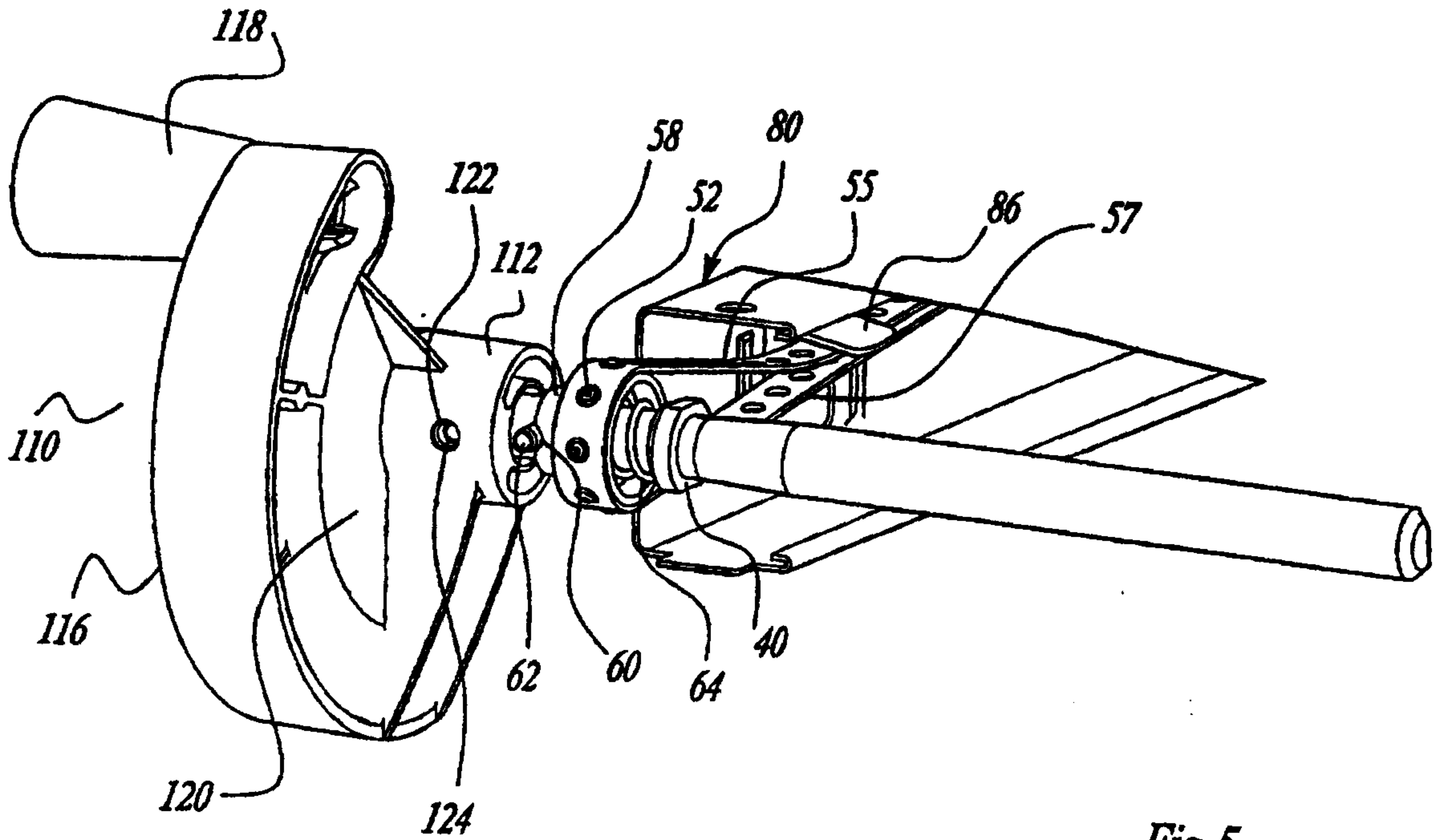

Fig-5

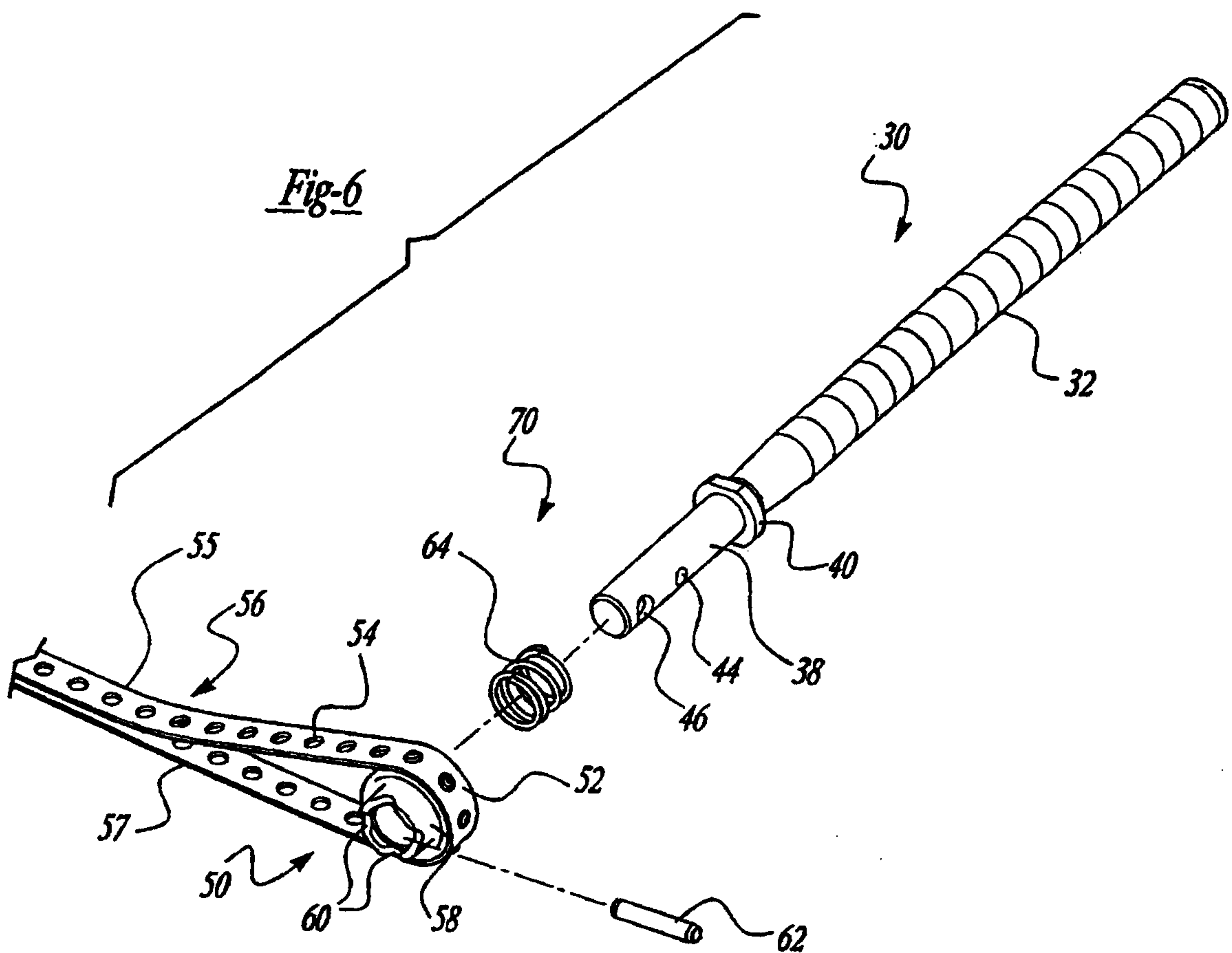

Fig-6

