

⑫ **EUROPEAN PATENT SPECIFICATION**

- ④⑤ Date of publication of patent specification: **12.08.87** ⑤① Int. Cl.⁴: **H 04 L 11/20**
②① Application number: **83900462.9**
②② Date of filing: **12.01.83**
⑧⑧ International application number:
PCT/US83/00041
⑧⑦ International publication number:
WO 84/00265 19.01.84 Gazette 84/02

⑤④ **FAST PACKET SWITCH.**

- | | |
|---|--|
| <p>③⑧ Priority: 25.06.82 US 392378</p> <p>④③ Date of publication of application:
11.07.84 Bulletin 84/28</p> <p>④⑤ Publication of the grant of the patent:
12.08.87 Bulletin 87/33</p> <p>⑧④ Designated Contracting States:
BE CH DE FR GB LI NL SE</p> <p>⑤⑧ References cited:
US-A-4 049 906
US-A-4 284 976</p> <p>IEEE Transactions on Computers, volume C-28,
no. 10, October 1979, New York (US); A.
Hopper et al.: "Binary Routing Networks",
pages 699-703</p> | <p>⑦③ Proprietor: Western Electric Company,
Incorporated
222 Broadway
New York, NY 10038 (US)</p> <p>⑦② Inventor: TURNER, Jonathan Shields
7436 Washington
University City, MO 63130 (US)</p> <p>⑦④ Representative: Lawrence, Brian Richard et al
Western Electric Company Limited 5,
Mornington Road
Woodford Green Essex IG8 OTU (GB)</p> |
|---|--|

EP 0 112 831 B1

Note: Within nine months from the publication of the mention of the grant of the European patent, any person may give notice to the European Patent Office of opposition to the European patent granted. Notice of opposition shall be filed in a written reasoned statement. It shall not be deemed to have been filed until the opposition fee has been paid. (Art. 99(1) European patent convention).

⑤ References cited:

ICC'80 Conference Record, volume 3, 8-12 June 1980, New York (US); S.S. Lam: "A Packet Network Architecture for Local Interconnection", pages 39.2.1 - 39.2.6
Comcon 80, 20th IEEE Computer Society International Conference, San Francisco, 25-28 February 1980, New York (US); C.H. Séquin: "Message Switching Circuits for Multi-Microprocessors", pages 328-334
Software & Microsystems, volume 1, no. 3, April 1982, Camberley (GB); F. Halsall et al.: "Prototype X25 exchange for use in local area networks", pages 69-73

Proceedings of the IEE, volume 119, no. 12, December 1972, Stevenage (GB); T.H. Beeforth: "Proposed organisation for packet-switched data-communication network", pages 1677-1682

Description

Cross-reference to related applications

Concurrently filed herewith and assigned to the same assignee as this application are:

- 5 "An Interface Facility for a Packet Switching System", European Patent Application No. 83900465.2;
 "End-to-End Information Memory Arrangement in a Line Controller", European Patent Application No. 83900598.0;
 "Time Stamping for a Packet Switching System", European Patent Application No. 83900516.2 and
 "A Fast Packet Switching Network", European Patent Application No. 83900515.4.

10

Technical field

This invention relates to a packet switch for switching packets of digital signals between a plurality of input terminals and a plurality of output terminals, and said switch comprising, a plurality of input control means each of which is connected to an individual one of said input terminals, as plurality of output control
 15 means each of which is connected to an individual one of said output terminals, means individually connecting each of said input control means to each of said output control means.

Background of the invention

The advantages of transmitting data and voice information in packets has long been recognized. Packet
 20 switching provides a known solution to problems where the information to be transmitted occurs in short, high-rate bursts, with long pauses between bursts.

As the number of different applications for packet switching grows, the requirements have become more stringent on packet switching systems. They must be capable of routing the packets to their destination, preferably through the use of an address contained within the packet itself. In addition, the
 25 system must provide buffering at different nodes within the system to allow for the temporary storage of packets if the intended route of those packets is temporarily experiencing traffic delays. Many of the emerging applications for packet switching, such as for the switching of digitally encoded voice information, require a packet switching system having thousands of the switching nodes. An important goal in the design of such large packet systems is that each node be capable of rapidly switching packets
 30 and especially have a reasonable physical size.

Prior art systems for switching packets have been rather small systems consisting of only a few hundred nodes. In addition, such systems have employed large computers using sophisticated software packages to perform the packet switching functions at the nodes within the system. The systems customarily have used complex control protocols to handle the problems of error recovery and flow control
 35 and, as a result, have had a limited packet handling capability of only a few thousand packets per second.

Typically, in the prior art, when a packet was received, a computer examined the logical address to determine the destination of the packet and then executed the necessary steps to effect a transmission of the packet to that destination. The process involved the time consuming steps at each node of translating the logical address into a physical address of the transmission link over which the packet was to be
 40 retransmitted, and then, after receiving and buffering the entire packet, performing error and flow control function followed by actual packet retransmission to a succeeding node. Obviously, such a complicated process results in substantial throughput switching delays and undesirably introduces variable delays at the different switching nodes which culminates in packets arriving out of sequence at their destination.

"Binary Routing Networks", *IEEE Transactions on Computers*, Vol. C-28, No. 10, October, 1979, (New
 45 York, U.S.) A. Hopper, et al., pages 699—703, indicates the possibility of performing address rotation by a packet switching node within a packet switching system. The extent of this disclosure is the statement on page 699 that "to minimize the delay through each node the routing bits can be rotated so that the first bit of the route field always indicates the next field". No further disclosure of rotating the address bits is given in this article or how such rotation would be implemented.

U.S. Patent 4,284,976, describes segment interface circuits for interexchanging packets between a broadcast medium such as optical fibers or satellite communications in a packet switching system. The segment interface circuits are responsive to packets being transmitted on one broadcast medium to transfer these packets to another broadcast medium if the most significant address of the destination
 50 address field indicates the packet is intended for the other broadcast medium. Before transferring the packet to the other broadcast medium, the segment interface circuit removes the most significant address from the destination field and places it in the source address field. The segment interface circuitry does not address translation nor does it form a new type of packet.

"A Packet Network Architecture for Local Interconnection," *ICC' 80 Conference Record*, Vol. 3, June 1980, (New York, U.S.) S.S. Lam, pages 39.2.1—39.2.6, describes a packet switching network based upon
 55 broadcast coaxial cables and is intended as a local network environment.

U.S. Patent 4,049,906, describes a digital message network for the communication of address coded telegrams between a plurality of subscriber stations. The originating subscriber station transmits a telegram message to a destination subscriber station by first inserting the actual complete physical address
 60 necessary to route the telegram through the digital message network to the destination subscriber station. The subscriber station/switching nodes are responsive to telegrams to examine the physical address and to
 65

properly route the telegram to the next subscriber station. The patent teaches that as each subscriber station processes its portion of the physical address, it deletes this portion of the physical address so that the physical address becomes shorter and shorter as the telegram proceeds through the network, column 4, lines 37 through 43. The patent does suggest that another way in which the address could be handled
 5 would be to rotate the physical address as it proceeds from the subscriber station to subscriber station, but no disclosure is given of how this would be implemented, column 4, line 35.

"Message Switching Circuits for Multi-Microprocessors," *COMPCON 80 Conference Proceedings, IEEE Computer Society*, February, 1980 (San Francisco, U.S.) C.H. Sequin, pages 331—333, described in Section 3.2 a transmission protocol between switching modes whereby upon receiving each byte of a packet, the
 10 receiving node transmits an acknowledge signal back to the transmitting node. Fig. 4 illustrates a timing diagram utilizing this protocol.

"Prototype X25 Interchange for Use in Local Area Networks," *Software and Microsystems*, Vol. 1, No. 3, April, 1982, (Camberley, GB), F. Halsall, et al., pages 69—73, describes a multiprocessor packet switch utilizing the CCITT standard protocol X25.

"Proposed Organization for Packet Switched Data—Communication Network," *Proceedings of the IEEE*, Vol. 119, No. 12, December, 1972, (London, GB) D.H. Beeforth, et al., pages 1677—1682, describes a system which employs adaptive message routing and, in particular, uses a route-switch packet to establish route information at each node within the switching system. The route-search packet is transmitted from an
 15 originating terminal to a destination terminals for setting up a route for a message. Each node in response to the route-search packet determines the most suitable link for forwarding the route-search packet to the next node and stores entries in the route list necessary to route subsequent packets of the message. When the route-search packet is received at the destination terminal, the destination terminal transmits a route-reply packet to the destination terminal over a reverse path of the route. The route address information necessary to communicate subsequent message packets is stored at each node.

Not only are known prior art systems unable to implement a toll switching network function because of the undesirable switching delay, but the existing structures for switching node architectures heretofore would be physically too large if expanded to perform the toll function. The prior art architectures do not lend themselves well to physical reductions which are possible through the use of very large scale integration (VLSI).
 25

30 Summary of the invention

The problems are solved in accordance with this invention in a packet switching system in which each of said packets comprising an address field of said digital bit signals defining a packet communication path from an individual one of said input control means over said connecting means and an individual one of
 35 said output control means to said individual one or said output terminals connected thereto, the input control means comprises, means for storing address and other digital bit signals of a packet received from said individual one of said input terminals and means responsive to a receipt of said address signals for sending a packet communication request signal to the address designated output control means, means for controlling said storing means to commence a transmission therefrom of address and other digital bit
 40 signals of said received packet to the one of said output terminals identified by the stored address signals of said packet immediately upon receipt of a packet communication availability signal indicating an idle condition of said defined one of said output terminals.

A departure in the art is achieved with an integratable high-speed switching network having a plurality of switching nodes interposed between a plurality of input and output conductors and with each such node
 45 comprising a circuit responsive to a receipt of a predetermined group of bits in a bit pattern from the input conductors for steering the bit group to a subsequent one of the switching stages or to the output conductors. Each node further comprises a circuit for repositioning the group of bits to a different location in the bit pattern incident to the steering. The steering circuit is responsive to the predetermined group of bits appearing in the most significant bit position of the bit pattern, and the repositioning circuit relocates
 50 that group of bits to a less significant bit position of the bit pattern prior to the steering.

The network architecture comprises interconnected switching nodes and a protocol of operation between those switching nodes which allows for the interchange of signals that determines whether or not a packet can immediately be transmitted to the next sequential switching node without full buffering of the entire packet. The protocol provides that each switching node determines the next sequential switching
 55 node illustratively in response to the most significant bits of the address contained in each packet. The protocol utilizes dynamic path availability signaling between cooperating switching nodes to reduce packet buffering delays and increase the speed of packet switching through the system.

Packet buffering delays are reduced by equipping each input of a switching node with a variable length buffer. The latter stores a portion of an incoming packet until the dynamic signaling from the next sequential switching node specifies that packet transmission can immediately commence to that switching
 60 node. The use of the variable length buffer and signaling protocol allows the system architecture to utilize only the minimum amount of buffering required to communicate a packet through the entire switching network and, therefore, greatly reduces the time delay encountered by the packets.

The illustrative method involves the steps of storing the packet in a first stage switching node,
 65 decoding the address field of the packet to define a second stage switching node and retransmitting the

packet significantly with a rotation of bits in the address field that designated the second stage switching node. The address bit rotation provides for operational uniformity of each switching node and for fast switching by having each node respond immediately to the first received most significant address bits appropriate to that node.

5 Advantageously, the signaling protocol is arranged so that second stage switching nodes dynamically transmit in real time to each of the first stage switching nodes to which they are connected, an illustrative link open signal when the buffer in the second stage switching node is free to accept another packet. Upon receiving the link open signal, a first stage switching node immediately commences retransmission of any portion of the packet contained within its buffer whose address field designates a second stage switching
10 node that has transmitted the link open signal. This dynamic transmission of the link open signal between first and second stage switching nodes allows the packet to be only buffered, or delayed, within the first stage for the minimal amount of time required until it can be retransmitted to the second stage. Hence, the method reduces the delay incurred by a packet during transmission through the switching network.

The switch network architecture results in Fast Packet Switching Network (FPN) which is constructed
15 with a plurality of switching nodes each of which advantageously comprises a plurality of input and output control circuits illustratively embodying the address rotation structure, variable buffering structure, and the signaling protocols for fast packet switching. The exemplary network is arranged to interconnect functional facilities which interface illustratively with central processors, transmission facilities, and concentrators. In the illustrative embodiment, the interface facilities are designated trunk controllers.

20 Each of the switching nodes is illustratively configured in a 4x4 arrangement including four input and four output conductors connectible to four trunk controllers and four other switching nodes of the network. Four input and four output control circuits advantageously switch any input conductor to any output conductor in response to address information contained in an incoming packet and under control of the signaling protocol.

25 The switching node architecture facilitates its fabrication by VLSI technology. It advantageously does so by utilizing identical node circuitry and modes of operating that circuitry together with a minimal number of conductors for connection to trunk controllers and other switching nodes. To elaborate, a single conductor is used for both control signaling and data communication to a succeeding switching node or attached trunk controller. Multiple conductors within a VLSI chip are used between input and output control
30 circuits of the same switching node for packet communication and protocol signaling. The use of VLSI technology effectively reduces the physical requirements and operational complexity.

It is an advantage of the present invention that the illustrative packet switching network utilize an address rotation structure at each switching node for rotating binary bits in the address field of a received packet to speed-up packet switching and to provide uniformity in the operation of switching nodes. By way
35 of example, the address field is arranged with most significant, intermediate and less significant bits for progressively defining a path through the switching network(s) of the system. Operationally, each switching node is responsive to the most significant bits to define the immediate path through that switching node and then those bits are rotated to the less significant category and the intermediate bits become the most significant for the next switching node. This provides for uniformity of switching node
40 circuitry and its routing operation only in response to the most significant address bits which are serially received first at each node and acted upon at each node to advantageously contribute to the speed of packet switching.

A feature of the present invention is that a signaling protocol is used between the input and output control circuits within a switching node and between the output control circuit of that node and a
45 downstream input control circuit of another switching node. The node and internode protocol increases the speed of packet switching by signaling exchanges of link open and packet transmission request and grant signals within the node circuitry and among cooperating interconnected nodes.

Each input control circuit is equipped with a buffer for the storage of packets. The present invention utilizes the node and internode signaling protocol for enabling that buffer to store the contents of a
50 received packet only until it is ascertained that the path through the node to a succeeding node or trunk controller is free for packet communication thereto. The link open, request and grant signaling effects an immediate transmission from the buffer with minimal delay to the destination specified by the address information within the packet itself.

Each input control circuit is further equipped dynamically to signal a link open condition over its input
55 conductor for signifying that its buffer is free to receive and store a packet of information. An output control circuit of an upstream switching node is responsive to that link open signal to, in turn, signal all input control circuits of the same node that transmission is allowed, or granted, through that output control circuit immediately upon a signaling request from one of those input control circuits. As a result, buffering delays are terminated at that point and fast packet switching occurs.

60 A salient feature of this invention is the provision of a packet switch for switching packets of digital signals between a plurality of input terminals and a plurality of output terminals. The switch comprises a plurality of input control circuits each of which is connected to an individual one of the input terminals and a plurality of output control circuits each of which is connected to an individual one of the output terminals. The switch further comprises means individually connecting each of the input control circuits to each of the
65 output control circuits. Each of the packets comprises an address field of digital signals defining a packet

communication path from an individual one of the input control circuits over the connecting means and an individual one of the output control circuits to the individual one of the output terminals connected thereto. The defined one of the input control circuits is equipped with a controller responsive to a receipt of the address field signals for sending a packet communication request signal over the connecting means to the individual one of the output control circuits. The defined one of the output control circuits comprises circuitry for supplying a signal over the connecting means to each of the input control circuits to signify the packet communication availability of the defined one of the output control circuit and the individual one of the output terminals connected thereto. Each of the defined ones of the input and output control circuits is further responsive to the supplied availability and request signals for communicating digital signals of a received packet over the defined packet communication path from the defined one of the input control circuits over the connecting means and the defined one of the output control circuits to the defined one of the output terminals connected thereto.

A feature of the invention is a packet switching network comprising first and second switching stages each of which has a plurality of switching elements each having input and output terminals. Each of the input terminals of the first stage is connectible to an individual input conductor. Each of the output terminals of the first stage is connected to an individual one of the input terminals of the second stage. Each of the output terminals of the second stage is connectible to an individual one of the output conductors. Each of the switching elements advantageously comprises for each of one of the input terminals thereof a buffer for storing address and other digital signals of a packet received on each one of the input terminals and a controller for controlling the buffer to commence a transmission therefrom of the address and other digital signals of the packet upon a receipt of a control signal indicating an idle condition of the one of the output terminals identified by the stored address signals of the packet in the buffer.

Each buffer stores information in shift register facilities and utilizes a counter to determine where the first bit of a packet is within the register facilities. When the controller in an input control circuit receives a grant signal from an appropriate output control circuit, the data selector cooperates with the controller which is responsive to the counter to select the first bit of the stored packet for immediate transmission of the packet to the output control circuit.

Illustratively, each input control circuit is responsive to the most significant address bits to select the output control circuit defined by those bits. Thereafter, an address rotation circuit on the input control circuit rotates all address bits so that the most significant bits become the least significant. The input control circuit performs the rotating operation by the cooperation of two of its shift registers and a data selector. The data selector selects the output of one of the two shift registers. The output of the first shift register also feeds into the input of the second shift register. Initially, the packet is flowing through the first shift register to the second shift register and through the data selector for transmission to the defined output control circuit of the same switching node. When the most significant set of address bits are present in the second shift register, the data selector selects the output of the first shift register for transmission to the output control circuit. The most significant address bits are not shifted until the last bit of the address field has been shifted out of the first shift register to the output control circuit. Thereupon, the data selector selects the second shift register for sending the stored most significant address bits in the least significant positions of the address to the appropriate output terminal. The result of these operations is that the most significant set of address bits are now rotated to the end of the address field and the next node operates on the bits newly shifted into the most significant status.

Brief description of the drawing

Figs. 1 and 2 illustrate, in block diagram form, a communication system utilizing the switching architecture of the present invention;

Fig. 2A functionally illustrates a switch node within the network architecture;

Fig. 3 illustrates the contents of a call setup packet which is routed from an originating customer terminal to a destination customer terminal through the switching system;

Fig. 4 illustrates the contents of the call reply packet transmitted from the destination customer terminal to the originating customer terminal in response to the receipt of the call setup packet;

Fig. 5 is a detailed block diagram of switching network 116;

Fig. 6 illustrates a switch packet which is used to route the call setup packet of Fig. 3 from trunk controller 130 to central processor 115 via switching network 116 and trunk controller 129;

Figs. 7 through 9 illustrate the contents of the switch packet used to transmit the call reply packet of Fig. 4 through switching network 116 as the packet progresses through the different stages of switching network 116 from trunk controller 131 to trunk controller 130;

Fig. 10 is a detailed block diagram of switching node 500-15 of switching network 116;

Fig. 11 is a detailed block diagram of input control 1000 of switching node 500-15;

Fig. 12 is a detailed block diagram of address rotation circuit 1106 of input control 1000;

Fig. 13 is a detailed block diagram of output control 1007 of switching node 500-15;

Fig. 14 illustrates, in block diagram form, trunk controller 131;

Fig. 15 illustrates the logical organization of memory 1401 of trunk controller 131;

Figs. 16 through 26 are detailed block diagrams of subsystems which comprise receiver 1402 of trunk controller 131;

0 112 831

Fig. 27 is a detailed block diagram of address control 1404 of trunk controller 131;
Fig. 28 illustrates the logical operation of address control 1404 in relationship to memory 1401;
Fig. 29 is a detailed block diagram of the implementation of pointers as used in receive interface 2701
of address control 1404;

5 Fig. 30 is a detailed block diagram of receive interface 2701;

Fig. 31 is a detailed block diagram of switch interface 1418 of trunk controller 131;

Figs. 32 through 40 are detailed block diagrams of subsystems which comprise input circuit 1406 of
trunk controller 131;

Fig. 41 is a block diagram of output circuit 1405 of trunk controller 131;

10 Figs. 42 through 44 illustrate packet transformations performed by the subsystems of output circuit
1405 of trunk controller 131 on packets read from memory 1401 of trunk controller 131;

Figs. 45 through 49 are detailed block diagrams of subsystems which comprise output circuit 1405 of
trunk controller 131;

15 Figs. 50 through 53 are detailed block diagrams of subsystems which comprise transmitter 1403 of
trunk controller 131; Fig. 54 is a timing diagram; and

Fig. 55 shows the manner in which certain of the figures should be arranged to show the specific
illustrative embodiment of the invention.

The drawing shows in Figs. 1 and 2 the heavy line block of a switching network for emphasis of the
principal building block of the present invention. The details of that network are set forth on Figs. 10
20 through 13 and a functional illustration of the network is shown in Fig. 2A.

Detailed description

Figs. 1 and 2 show an illustrative packet switching system having a plurality of local offices 102, 103,
108 and 109, and a plurality of toll offices 104—107 serving a plurality of customers such as customers 100
25 or 110. The following description first presents a general description of the subsystems comprising the
packet switching system of Figs. 1 and 2. Then a brief resume of a switching network and one of its switch
nodes with the node's variable buffering, address rotation, and intranode and internode signaling
protocols is given to provide a focus on the invention. Next, a description is presented of the manner in
which a packet transmitted from a customer 100 resident interface 127 to customer 110 resident interface
30 155 has the necessary self-routing information inserted into it by each trunk controller in its route through
the packet switching system. Once the routing of the packet through the switching system has been
described, the procedure used to compile the routing information is then described; and then, the method
used to store this information in each trunk controller in the route is described. Finally, a detailed
description of each block of Fig. 1 and 2 is given.

35 As shown in Fig. 1, local office 102 comprises a switching network 116 which terminates a plurality of
trunk controllers and which cooperates with central processor 115 via a central processor trunk controller
129 which is also connected to the switching network. Each trunk controller is tied into the network by
unilateral transmission media. Trunk controller 131, for example, receives information from switching
network 116 via conductor 132 and transmits information to switching network 116 via conductor 133.

40 On the customer side of local office 102, the local office is connected to customers via concentrators
which are interconnected to the switching network via trunk controllers. A concentrator has an internal
switching architecture similar to that of switching network 116 which is described in greater detail later and
has a self-contained trunk controller which interfaces the concentrator to the attached trunk. The
concentrator's trunk controller is similar to trunk controller 131 which is described in greater detail later.
45 Each concentrator has connected to it a microprocessor which is used in conjunction with the attached
access line controller to perform the initial call setup sequences and to provide call supervision as a
supplement to the inherent selfrouting characteristics of the packets being transmitted through the packet
switching system. The customer units are connected to the concentrators by the access line controllers.
Each access line controller stores logical address and control information which is stored in the access line
50 controller by the controlling microprocessor. This logical address information is used to control the first
portion of the route taken by the packets transmitted through the attached switching network via the
interconnecting trunk controller. Each access line controller is connected to a resident interface contained
within each customer unit via standard bilateral transmission media. Packets are transmitted between the
access line controllers and the resident interfaces using standard packet protocols which define three
55 virtual channels for communication between the resident interface and the access line controller.

Each trunk controller comprises a memory containing a translation table for converting the logical
addresses into switch addresses which are used by the switching network to route the packets to the
destination trunk controller. Switching network 116 is interconnected to toll offices such as 104 by high
speed trunks with each trunk being terminated on both ends by a trunk controller. The subject matter of Fig.
60 1 is substantially duplicated in Fig. 2.

Turning now to Fig. 2A, a functional representation of switching network 116, is shown comprising
three stages of switching nodes. Switching node 200 through 201 comprise stage 1, switching nodes 210
through 211 comprise the second stage, and switching nodes 220 through 221 comprise the third stage.
More detail with respect to the modular interconnection of the various switching nodes is given in the
discussion of Fig. 5. Each switching node modularly comprises four input control circuits and four output
65

control circuits as illustrated by switching node 201. The other switching nodes are identical in design to switching node 201. Switching node 201 has four input control circuits 230 through 233 and four output control circuits 240 through 243. Each input control circuit has one output cable connected to each of the output control circuits. The output cables carry both data and control signals between the input and output control circuits. The details of a switching node are given in the discussion of Fig. 10. The composition of an input control circuit is shown by the block diagram of input control 230, and further details of an input control circuit are given in the discussion with respect to Figs. 11 and 12. Similarly, the composition of an output control circuit is shown by output control 243 and a more in depth discussion is given with respect to Fig. 13.

As a packet is initially received by input control 230, the packet is variably buffered in memory 251 via receiver 250 until transmission can commence to an output control circuit designated by the address in the packet, such as output control 243. Assuming the address designated output control 243, the retransmission starts as soon as switching node 211, can accept the packet; hence, it is not necessary to completely buffer a packet before retransmitting it. This variable buffering greatly reduces the time delay for switching packets through network 116 and is facilitated by the exchange of intranode signaling between the input and output control circuits within a node and by the internode signaling which takes place between the output control circuit of one node and the input control circuit of the designated switching node. The intranode signaling involves the utilization of request and grant signals between the input control circuits and the output control circuits after the input control circuit initially receives the start of the packet. The internode signaling involves the setting of the idle/busy flip-flop, such as flip-flop 261, in the output control circuit to the idle state by the connected downstream switching node when the latter is capable of receiving another packet. The downstream node sets the idle/busy flip-flop to the idle state by transmitting a link open, or packet communication available, signal to the output control circuit. In addition, the utilization of an address rotation circuit within the input control circuit properly to reposition the address bits before transmission to the next sequential node greatly increases the switching speed.

Considering Fig. 2A now in greater detail, input control 230 is responsive to the start of a packet from trunk controller 131 to store the first portion of the packet into memory 251 and to examine the address associated with the packet to determine the output control circuit designated thereby. Assuming that output control 243 is so designated, control 252 requests permission to immediately commence transmission from memory 251 to output control 243 by transmission of a request signal via cable 280. If the input control circuit of switching node 211 to which output control 243 is connected via link 281 is capable of accepting a packet, the idle/busy flip-flop 261 is set to the idle state. Upon receipt of the request signal from input control 230, output control 243 transmits back a grant signal via cable 280 and properly conditions data selector 263 to accept data from cable 280 if flip-flop 261 is set to the idle state. Upon receiving the grant signal, control 252 immediately causes memory 251 to commence transmission to output control 243 via address rotation circuit 253 and multiplexer 254. Control 252 properly conditions multiplexer 254 to properly select output control 243 for transmission. After the packet has been transmitted, output control 243 sets flip-flop 261 to the busy state.

The function of address rotation circuit 253 is to rotate all address bits such that the two most significant bits of the address are always presented to the next succeeding switch node. This is necessary for the modularity of all packet switch node operations and for speed of packet switching since the input control circuits always base their selection on the two most significant bits of the address and do not have to delay their switch actions which would otherwise occur without the rotation. When switching node 211 receives the packet from output control 243, the address is properly aligned so that the selection is immediately made based on that address.

When switches node 211 is capable of accepting another packet, it sets flip-flop 261 to the idle state indicating that another packet can be transmitted to switching node 211 by transmission of the link open signal via link 281.

Turning now from the network functions and structure, the procedure for obtaining and storing self-routing information in address memories of the appropriate address line controllers and trunk controllers is described. The information is obtained by a call setup packet being transmitted from the appropriate access line controller connected to the originating customer unit through the various microprocessors and central processors which are associated with the different concentrators and local and toll offices which form the route through which the call setup packet must transverse in order to reach the destination customer unit. As the call setup packet progresses along this route, each processing entity inserts a new logical address into the packet and stores the necessary logical and switch address information in the appropriate access line controller or trunk controllers. Once the call setup packet is received at the microprocessor attached to the concentrator to which the destination customer unit is connected via an access line controller, the receiving microprocessor transmits the appropriate logical and switch address information to the connected access line controller which stores it in its address memory; and the receiving microprocessor assembles and transmits a call reply packet which indicates that the call has been properly set up. After the call reply packet is received by the originating customer access line controller, all the necessary routing information is set up in the access line controllers and trunk controllers forming the packet route so that packets can be directly routed through the switching networks without the packets having to be handled by the associated processing entities.

0 112 831

The utilization of the call setup packet is now illustrated in greater detail by describing the establishment of a telephone call between customers 100 and 110. Customer 100 calls customer 110 by dialing the customer 110 telephone number. Resident interface 127 collects the dialed digits in the conventional manner. After resident interface 127 has collected the dialed digits, it transmits the dialed digits in a packet via line 122 to access line controller 112a. In response to the packet received from resident interface 127, access line controller 112a assembles and transmits the packet shown in Fig. 3 to microprocessor 111 via concentrator 112. The packet identifier field identifies this packet as a signaling packet and a "1" in the most significant byte of data field indicate that the packet is a call setup packet. The remainder of the data field contains the dialed telephone number.

Upon receipt of the packet of Fig. 3, microprocessor 111 examines the dialed telephone number and determines that a connection is required through switching network 116. First, microprocessor 111 transmits to access line controller a new logical address to be used in subsequent packets and the switch address defining concentrator 112's trunk controller which connects trunk 117 to concentrator 112. This switch address is used by concentrator 112 to route subsequent packets to trunk 117. Next, microprocessor 111 stores in concentrator 112's trunk controller the switch address identifying access line controller 112a and information defining the virtual channel to be used by access line controller 112a in communicating with resident interface 127. Finally, microprocessor 111 assembles a packet similar to the one shown in Fig. 3, but having the logical address in the logical address field which had been stored in the address memory of access line controller 112a. This new packet is then transmitted to central processor 115 via concentrator 112, trunk 117, trunk controller 130, switching network 116, and trunk controller 129.

Upon receipt of the packet from microprocessor 111, processor 115 determines from the dialed telephone number by performing a table look-up operation that the call must be sent through to office 104. Processor 115 first transmits the logical address contained in the received packet and the switch address identifying trunk controller 130 to trunk controller 131. Trunk controller 131 stores this address information in an internal memory and uses this information to perform the necessary logical to switch address translation on subsequent packets associated with the call being set up. Processor 115 then transmits to trunk controller 130 a new logical address and the switch address identifying trunk controller 131. This address information is used to perform the necessary logical to switch address translation for routing packets from trunk controller 130 to trunk controller 131 associated with the call being set up through switching network 116. The last operation performed by processor 115 is to transmit a call setup packet similar to that shown in Fig. 3 to central processor 113 via switching network 116, trunk controller 131, trunk 118, trunk controller 140 and switching network 146. The packet transmitted to processor 113 has in the logical address field the logical address information identical to that previously stored in trunk controller 130.

Upon receipt of the packet from trunk 118, processor 113 performs operations in response to this packet similar to those performed by processor 115 as previously described with respect to the call setup packet. Processor 113 then transmits a call setup packet to central processor 123 via switching network 146, trunk controller 142, trunk 119 trunk controller 147, and switching network 148. Processor 123 performs similar operations to those performed by processor 113 and transmits a new call setup packet to central processor 114 via switching network 148, trunk controller 149, trunk 120, trunk controller 150, and switching network 151. Upon receipt of the call setup packet from processor 123, central processor 114 stores the logical address information of this packet and the switch address designating trunk controller 150 in trunk controller 141. Central processor 114 then transmits a new logical address and the switch address designating trunk controller 141 to trunk controller 150, which stores this information. After storing the necessary information in trunk controllers 141 and 150, processor 114 assembles a new call setup packet having the logical address which had previously been stored in trunk controller 150 in the logical address field and transmits this call setup packet to microprocessor 125 via switching network 151, trunk controller 141, trunk 124, and concentrator 126.

Upon receipt of the call setup packet from processor 114, microprocessor 125 reads the logical address information contained in the logical address field and stores the logical address in address memory 152 of access line controller 126a. Microprocessor 125 then transmits a call reply packet as illustrated in Fig. 4 to microprocessor 111 via the previously defined route through the packet switching systems of Figs. 1 and 2. The logical address field of the packet of Fig. 4 contains the logical address which microprocessor 125 received in the call setup packet from processor 114. Trunk controller 141 is responsive to the receipt of the packet of Fig. 4 to translate the contents of the logical address field using the previously stored logical address to switch address translation information and to insert the previously stored logical address into the call reply packet. The switch address which results from this translation by trunk controller 141 designates trunk controller 150. This switch address is used by switching network 151 to route the call reply packet to trunk controller 150. Trunk controller 150 is responsive to receipt of the call reply packet to transmit this packet to trunk controller 149 via trunk 120. The call reply packet is similarly routed through the various trunk controllers until it is received by microprocessor 111. Once the call reply packet is received by microprocessor 111, all the necessary information for routing calls through the various switching networks is stored within the trunk controllers and access line controllers in the route.

Switching network 116 of local office 102 is shown in greater detail in Fig. 5. All connections to switching network 116 are made through the trunk controllers shown on Fig. 1. The trunk controllers

receive information at a 1.54 Mb/s rate and transmit this information into the network at an 8 Mb/s rate. Each trunk is capable of buffering five packets of information from the attached trunk. The buffering of packets at the input from the trunks is necessary because the packets may have to be delayed before they can be transmitted through the network. Buffering is also needed by the trunk controllers for information being received from the network before it can be retransmitted on the attached trunk. Each trunk controller is capable of buffering up to 40 packets of information from the network before commencing retransmission out on the trunk. Each trunk controller has one input connection and one output connection to switching network 116. For example, trunk control 130 transmits information to switching network 116 via conductor 134 and receives data from switching network 116 via conductor 135 as shown in Fig. 5.

The network itself comprises three stages of switching nodes. The first stage comprises nodes 500-0 through 500-15, the second stage comprises switching nodes 501-0 through 501-15, and the third stage comprises switching node 502-0 through 502-15. Transmission through the network is from left to right. Each switching node is a packet switch. Each packet switch has four inputs and is capable of buffering one packet on each input. The packets received on any input are transmittable on any of the four output terminals of the packet switch. After receipt of a packet on an input terminal, the address contained in that packet is used to determine which output terminal should be used to retransmit the packet. Only the two most significant bits of the address are used to designate the output terminal for a particular switching node. For example, switching node 500-12 retransmits the packet on line 505 if the most significant bits are equal to zero, on line 506 if the most significant bits are equal to one, on line 507 if the most significant bits are equal to two, and on line 508, if the most significant bits are equal to three.

Each node properly rearranges the address bits so that the receiving switching node in the next stage has the correct bits in the most significant bit positions in order to determine which output terminal should be used to retransmit the packet at that stage.

The operation of switching network 116 as shown in Fig. 5 can be better understood by considering the example of the switching of the packet shown in Fig. 3 through this network to central processor 115. The packet shown in Fig. 3 is transmitted by microprocessor 111 via trunk 117 to switching network 116. Upon receipt of the packet shown in Fig. 3, trunk controller 130 forms a new packet which is illustrated in Fig. 6.

The new packet is formed by taking the original packet received from trunk 117, removing the flags and stuffed bits, and then adding the new fields of start bit, packet length, destination trunk controller, source trunk controller, control, arrival time, and a new CRC field. Trunk controller 130 responds to the packet identifier containing a "0" by inserting a "0" into the destination trunk controller field. This is the trunk number for trunk controller 129 to which central processor 115 is connected. Trunk controller 130 inserts its own output connection number on switching network 116 (in this example 48) into the source trunk controller field. The start bit defines the start of the network packet and the packet length defines the length of the network packet. Trunk controller 130 inserts into the arrival time field the relative time of day. Once the packet of Fig. 6 has been formed and the input 513 of node 500-12 is idle, trunk controller 130 transmits this packet to node 500-12.

Node 500-12 examines the most significant bits of the address field and selects output 505 since these bits are zero. Before transmitting this packet to node 501-12 via output terminal 505, node 500-12 rotates the address field two bits to the left; this results in the two most significant bits becoming the least significant bits, and the two middle bits of the address field shown in Fig. 6 becoming the two most significant bits.

Node 501-12 examines the address field upon receiving it and selects output 512 since the most significant bits are zero. Node 501-12 also rotates the address field two bits to the left. Node 501-12 transmits the packet to node 502-0 via the output terminal 512. Upon receipt of the packet, node 502-0 examines the address field and selects output terminal 514 since the two most significant bits of the address are zero. Upon receiving the packet, trunk controller 129 strips off the start bit, network address field, and network packet length, and transmits to central processor 115 the packet identifier, logical address, time stamp, and data fields plus a recalculated CRC field.

A second example will be used to help illustrate the operation of switching network 116 as shown in Fig. 5. This will be done by following the transmission of the packet shown in Fig. 4 through switching network 116 from trunk 118 to trunk 117. Upon receipt of the packet shown in Fig. 4, trunk controller 131 forms the packet shown in Fig. 7. After forming this packet, trunk controller 131 transmits this packet to switching node 500-15 via input terminal 515. Switching node 500-15 examines the two most significant bits of the network address field (in this example a binary three), and selects link 516 to transmit the packet shown in Fig. 7. Before switching node 500-15 starts to transmit the packet via link 516, switching node 500-15 performs a left rotate operation on the network address field, and the result is the packet shown in Fig. 8. Upon receiving the packet from switching node 500-15, switching node 501-15 examines the two most significant bits of the network address field as shown in Fig. 8 and selects output 517 to transmit the packet out. Before transmitting the packet, switching node 501-15 performs a left rotate operation on the packet, resulting in the packet shown in Fig. 9. Upon receiving the packet of Fig. 9, switching node 502-12 responds to the network address field by transmitting the packet to trunk controller 130 via conductor 135. Switching node 502-12 also performs the left rotate operation on the network address field. The packet that is transmitted to trunk controller 130 via conductor 135 is identical to the packet shown in Fig. 9 with the network address field rotated. Trunk controller 130 forms a new packet which is identical to that shown in

Fig. 9 with the exception that the start bit, network packet length, destination trunk controller, source trunk controller, control, and arrival time fields have been eliminated, a new CRC field has been calculated and inserted, and the time stamp field has been updated. Trunk controller 130 then retransmits this new packet on trunk 117.

5 It would be obvious to one skilled in the art to expand network 116 as shown in Fig. 5 to be capable of terminating more trunks by the addition of more switching nodes. In addition, it would be obvious to one skilled in the art to use such a switching network to correctly interconnect several pieces of digital equipment such as computers or terminals. The other switching networks and concentrators shown in Fig. 1 and 2 are similar in design to switching network 116.

10 Switching node 500-15 is illustrated in greater detail in Fig. 10. The other switching nodes are identical in design to switching node 500-15. The switching node consists of four input controls which can transmit information to any one of four output controls. The input controls 1000 through 1003 are connected to the output controls 1004 through 1007 via cables. For example, input control 1000 is connected to output control 1007 via cable 1008. Cable 1008 comprises three conductors 1009, 1010, and 1011. The other
15 interconnecting cables on Fig. 10 are identical in design to cable 1008.

When input control 1000 has a packet to transmit to output control 1007, it transmits a request signal via conductor 1010 to output control 1007. Input control 1000 continuously transmits this request signal until the entire packet has been transmitted to output control 1007. When output control 1007 is free to receive information from input control 1000, output control 1007 transmits a grant signal via conductor
20 1011 to input control 1000. Upon receipt of the grant signal, input control 1000 commences to transmit the packet to output control 1007 via conductor 1009.

For example, the packet shown in Fig. 7 would be transmitted through switching node 500-15 as illustrated in Fig. 10 in the following manner. When input control 1000 recognizes the start bit, it has already received not only the start bit but also the two most significant bits of the network address. Input control
25 1000 decodes the two most significant bits of the network address field and determines that the packet was to be transmitted to output control 1007 via cable 1008. Input control 1000 requests permission to start transmission via conductor 1010; and when output control 1007 returns the grant signal via conductor 1011, input control 1000 starts the transmission of the packet to output control 1007 via cable 1008. Before
30 transmitting the network address field, input control 1000 left rotates this address two bits so that the network address transmitted is that shown in Fig. 8. Upon receipt of the start bit of the packet, output control 1007 starts to retransmit this packet out on link 516.

Input control 1000 of Fig. 10 is shown in greater detail in Fig. 11. Input circuit 1110 receives the information from input terminal 515 and transmits to trunk controller 130 of Fig. 11 the link open signal via input terminal 515 under control of controller 1104. The function of the link open signal will be explained in
35 a later section describing output control 1007. Input shift register 1100 is used to detect the start bit, which indicates the beginning of a packet. In addition, input shift register 1100 is used to extract the network packet length field, which is saved in length register 1102, and to extract the two most significant bits of the network address field, which are saved in address register 1101. The buffer shift register 1103 is capable of buffering one complete packet. Buffer shift register 1103 provides an output after each 64 bits of storage.
40 These outputs can be selected by data selector 1105 under control of controller 1104 to bypass unused portions of the buffer shifter register 1103. This bypassing is done when it is not necessary to buffer a whole packet before transmission of the packet can start to the output circuit and is done to speed up the transfer of a packet through input control 1000. Address rotation circuit 1106 performs the previously mentioned left rotate operation on the network address field before this address is transmitted with the
45 remainder of the packet to the selected output control. Multiplexer 1107 under control of controller 1104 selects which of the cables 1008, 1012, 1013 or 1014 the data is to be transmitted on.

The operation of input control 1000 will now be further explained by using the previous example which dealt with the transmission of the packet shown in Fig. 7. Input shift register 1100 is continuously being clocked by system clock 161 via conductor 1111. As data is received via input terminal 515, it is clocked
50 through input shift register 1100. Once the start bit reaches bit position 10 of input shift register 1100, controller 1104 detects this bit and transmits a pulse on conductor 1113. This pulse causes length register 1102 to store the network packet length field, and causes address register 1101 to store the two most significant bits of the network address field, which are contained in bit positions 0 and 1 of input shift register 1100.

55 Controller 1104 transmits a request via conductor 1010 to output control 1007 since the most significant address bits indicate that the packet is to be transmitted to this output control. While this request is being made, data is being shifted from input shift register 1100 to buffer shift register 1103 which has a number of output terminals. These output terminals are connected to different bit positions within buffer shift register 1103. When controller 1104 receives a grant signal from output control 1007 via conductor
60 1011, controller 1104 calculates at which output of buffer shift register 1103 the start bit of the packet is approaching within buffer shift register 1103. This is done so that transmission of the packet to output control 1007 can start as soon as possible. On the basis of this calculation, controller 1104 controls data selector 1105 to select the designated output of buffer shift register 1103. The control information is transmitted to data selector 1105 via cable 1117. Data selector 1105 transmits the data from the selected
65 output to address rotation circuit 1106 via conductor 1116. Before transmitting data, controller 1104 resets

address rotation circuit 1106 by transmitting the start of packet signal via conductor 1119. The controller 1104 then uses the packet length information stored in length register 1102, which it reads via cable 1120, to determine when the end of the packet has entered the input shift register. When this occurs and transmission has started from shift register 1103, controller 1104 transmits the link open signal via conductor 1115. This signal is retransmitted via tri-state driver 1109 and input terminal 515 to input port 503-60. The link open signal indicates that input control 1000 is now ready to receive another packet. This function is explained in the section dealing with the output control circuit.

Address rotation circuit 1106 is illustrated in greater detail in Fig. 12. The purpose of circuit 1106 is to rotate the address field to the left two bits so that the two most significant bits become the least significant bits. The rotation is necessary because each input control decodes only the two most significant bits. Shift registers 1200 and 1203 are two bit shift registers, data selector 1202 is used to select either the output of shift register 1200 or shift register 1203, and control circuit 1209 controls the operation of the address rotation circuit. When control circuit 1209 receives the start of packet signal from controller 1104 via conductor 1119, it transmits a clock signal to shift register 1200 via conductor 1207, and to shift register 1203 via conductor 1205. This clock signal is derived from the signal received from system clock 161 via conductor 1210. Control circuit 1209 conditions data selector 1202 via conductor 1208 to select shift register 1203's output to be transmitted on conductor 1118. Control circuit 1209 then counts the number of bits that are being transmitted via conductor 1118; when the two most significant bits of the network address field are contained within shift register 1203, control circuit 1209 ceases to transmit the clock signal to shift register 1203 via conductor 1205, and conditions data selector 1202 to select the output of shift register 1200. Control circuit 1209 then waits until the remaining bits of the network address field have been transmitted via conductor 1118. At this point in time, control circuit 1209 commences to send clock signals to shift register 1203, and conditions data selector 1202 to select the output of shift register 1203. This operation results in the most significant bits of the network address field being rotated.

Output control 1007 is shown in greater detail in Fig. 13. Control circuit 1300 responds to requests from input controls 1000 through 1003, which are transmitted via cables 1008, 1015, 1016, and 1017. If flip-flop 1301 is set, control circuit 1300 responds to the request by transmitting a grant signal back to the requesting input control via one of the above mentioned cables. After acknowledging the request, control circuit 1300 conditions data selector 1303 to select the data conductor from the appropriate cable 1008, 1015, 1016, or 1017. Control circuit 1300 transmits the appropriate control information to data selector 1303 via cable 1308. Data selector 1303 transfers the data information received on the selected input terminal to conductor 1307. Tri-state device 1302 takes the information on conductor 1307 and transmits this data via link 516 to input circuit 1305, which is part of switching node 501-15. Control circuit 1300 controls the output of tri-state device 1302 via conductor 1309.

The operation of output control 1007 as shown in Fig. 13 will be explained in greater detail by considering the previous example of input control 1000 transmitting a packet of data to output control 1007 via cable 1008. When input control 1000 transmits the request signal via conductor 1010, control circuit 1300 transmits the grant signal to input control 1000 via conductor 1011 if the link 516 is not being used by one of the other input control circuits and the output of flip-flop 1301 is set. Assuming that flip-flop 1301 was set, control circuit 1300 transmits the grant signal to input control 1000 and conditions data selector 1303 via cable 1308 to select the data being transmitted on conductor 1009 and retransmit this data on conductor 1307. In addition, control circuit 1300 enables the tri-state device 1302 to transfer the information on conductor 1307 to link 516.

After input control 1000 has transmitted the entire packet, it removes the request signal from conductor 1010. Once the request signal is removed from conductor 1010, control circuit 1300 sends a reset signal to flip-flop 1301 via conductor 1310 and stops transmitting signals via cable 1308 and conductor 1309. Once the input control of the switching node 501-15 is capable of accepting another packet, it transmits the open link signal via conductor 1306, tri-state device 1311, and link 516. The open link signal sets flip-flop 1301 via the S input. Once flip-flop 1301 is set, control circuit 1300 can once again respond to request signals from the input controls.

Trunk controller 131 is shown in greater detail in Fig. 14. The other trunk controllers are similar to trunk controller 131. Trunk controller 131 receives packets from trunk 118 via receiver 1402, and transmits packets to trunk 118 via transmitter 1403. Trunk 118 is illustratively a telephone digital transmission facility with a data transmission rate of 1.544 Nb/s as described in Boyle, Colton, Dammann, Karafin, and Mann, "Transmission/Switching Interfaces and Toll Terminal Equipment", 56 *The Bell System Technical Journal* 1057, 1058 (1977). Receiver 1402 and transmitter 1403 are interfaced to the DSX-1 unit shown in Fig. 1 on page 1058 of the cited article. Trunk controller 131 transmits packets to switching network 116 via output circuit 1405, and receives packets from switching network 116 via input circuit 1406. Switch interface 1418 interfaces the input and output circuits to the switch network. Packets are transferred in and out of four circular buffers in memory 1401 via address control 1404. Address control 1404 contains pointers to the circular buffers that allow input circuit 1406, output circuit 1405, transmitter 1403, and receiver 1402 to read and write memory 1401.

Consider an example where normal data packets are transferred from trunk 118 to switching network 116. Incoming packets, similar to those shown in Fig. 3, are received by receiver 1402 in a serial fashion at a 1.544 Mb/s rate. Receiver 1402 adds the arrival time to the packet, and transforms the serial information

into a byte. Once it has assembled a byte, it transmits a write request, via control bus 1408, to address control 1404. Receiver 1402 then writes the byte into memory 1401 via data bus 1407 and address control 1404. The location in memory 1401 that the byte is written into is designated by the address pointers associated with receiver 1402. This process continues until receiver 1402 has transferred an entire packet
 5 into memory 1401. After receiver 1402 has transmitted an entire packet, it transmits an end of packet signal, via control bus 1408, to address control 1404. Address control 1404 then transmits a packet available signal, via control bus 1412, to output circuit 1405. This packet available signal is transmitted as long as there is a complete packet in memory 1401.

Output circuit 1405 reads the packet stored in memory 1401 by making sequential read requests to
 10 address control 1404 via control bus 1412. Address control 1404 maintains a pointer then determines which word in memory 1401 is associated with the packet to be transmitted into the network via output circuit 1405. Output circuit 1405 access and transmits packets at an 8 mb/s rate. In order to transmit packets to switching network 116, output circuit 1405 forms packets similar to those shown in Fig. 6. It does this by using the logical address field from the original packet to address the logical translation table, and
 15 calculating the packet length field. In addition, output circuit 1405 calculates a new CRC field, updates the control field, and adds a start bit. These operations are done in a serial fashion; however, an entire packet does not need to be buffered.

Consider another example where packets are transferred from switching network 116 to trunk 118. Packets from switching network 116 are received by input circuit 1406 via switch interface 1418. Input
 20 circuit 1406 forms this data into bytes. It then sends a write request via control bus 1414, and sends the packets via data bus 1413 to address control 1404. Address control 1404 writes the information into memory 1401, via memory address bus 1417, memory data bus 1415, and memory control bus 1416. When an active packet has been stored in memory 1401, input circuit 1406 transmits an end of packet signal to address control 1404 via control bus 1414. Address control 1404 then transmits a packet available signal to
 25 transmitter 1403 via control bus 1410. Transmitter 1403 makes a read request to address control 1404, and receives the packets via data bus 1409. Transmitter 1403 transforms the packets into packets similar to those in Fig. 4, and transmits them to trunk 118 at a 1.544 Mb/s rate. Transmitter 1403 also performs error checking, and recalculates the CRC field. In addition, transmitter 1403 updates the time stamp field of the packet. It does this by subtracting the arrival time from the present time, and adding this difference to the
 30 time stamp field.

Trunk controller 131 handles a variety of packets that are used for various purposes. These packets can be divided into the following general categories: normal data packets, trunk and switch test packets, maintenance read and write packets, and memory read and write packets. The types of packets are distinguished by different values in the packet identifier or control fields. Normal data packets carry data
 35 and signaling information between the trunk and switching network. These are the most common packets. Trunk test packets are used to test a trunk, including the two trunk controllers, and the actual trunk facility. This is done as follows. The test packet is formed by the associated central processor, and sent to the first trunk controller via the switching network. The first trunk controller performs a check on the CRC field of the packet to determine if any errors occurred during the transmission. If an error is found, the first trunk
 40 controller aborts the test packet; if no errors are found, the first trunk controller sends the test packet to the second trunk controller via the trunk facility. When the second trunk controller receives the test packet, it performs the same CRC check and, if no errors are found, loops the packet back to the first trunk controller, which then sends the packet back to the central processor, via the switching network. The central processor detects that a transmission error has occurred by noting that the test packet is not looped back after a
 45 period of time has elapsed. Switch test packets are used to test a path within the switching network. A switch test packet as sent by the central processor to a trunk controller through the switching network. The trunk controller relays the packet to a second trunk controller (specified in the packet), which then returns the packet to the central processor. Maintenance packets are used to send maintenance information, such as error statistics, between a trunk controller and its associated central processor. In a maintenance read
 50 operation, the central processor sends a maintenance read packet to the trunk controller. The trunk controller reads the information and writes it into the packet; it then returns the packet to the central processor. In a maintenance write operation, the central processor sends a maintenance write packet to the trunk controller. The trunk controller writes the information from the packet into the maintenance register, and then reads the same information out of the maintenance register. The information read out is placed in
 55 the maintenance write packet and sent back to the central processor. Memory packets allow the central processor to read and write information from specified memory locations. These packets work similarly to maintenance packets, with the exception that memory locations, and not the maintenance register, are read and written.

Fig. 15 illustrates the four packet buffers, and logical channel translation table contained in memory
 60 1401. Packets arriving from receiver 1402 are written into either receive buffer 1501 or trunk test buffer 1502. Trunk test buffer 1502 is reserved for test packets that are to be looped back over the trunk. All other arriving packets are sent to receive buffer 1501. Packets arriving from input circuit 1406 are written into either transmit buffer 1503 or switch test buffer 1504. Transmit buffer 1503 is for packets that are to be
 65 transmitted on the trunk via transmitter 1403. Switch test buffer 1504 is for switch test packets, and for

memory read and write packets. Logical translation table 1505 contains the logical to physical address translation information received from the central processor via memory write packets.

The reading and writing of the circular buffers in memory 1401 is controlled by read and write pointers, located in address control 1404. These read and write pointers point to the specific memory locations within the various buffers. Read or write pointers are provided for receiver 1402, transmitter 1403, input circuit 1406 and output circuit 1405. These pointers are used to read or write the various circular buffers, depending on the circuit. The structure is as follows: Receive circuit—receive buffer and trunk test buffer write pointers; output circuit—receive buffer and switch test buffer read pointers; input circuit—transmit buffer and switch test buffer write pointers; transmit circuit—transmit buffer and trunk test buffer read pointers.

In addition to the various read and write pointers, address control 1404 also contains temporary pointers. Receiver 1402 has access to one temporary pointer, which is used to save the value of the write pointer. At the beginning of each packet write operation, the temporary pointer is set to the same address as the write pointer. If an error is discovered while the packet is being written, the write pointer is set back to the address of the temporary pointer. In this way, the packet containing an error is overwritten, effectively discarding it. Input circuit 1406 has access to two temporary pointers. One is used to save the value of the write pointer. The other temporary pointer is used during memory write operations, and will be discussed later. Output circuit 1405 has access to one temporary pointer, which is used during memory read operations.

The following description shows the packet flow of an ordinary data packet from the trunk to the switch network. Receiver 1402 receives trunk packets, and pads the trunk packets with zeroes, in order to provide space in the packet to transform the trunk packets into switch packets. Once receiver 1402 has done this, it makes a write request to address control 1404, in order to write the packet into receive buffer 1501 in memory 1401. Address control 1404 receives the write request and makes the receive buffer write pointer available. Receiver 1402 then writes the packet into receive buffer 1501 at the address specified by the write pointer. Address control 1404 then sends a packet available signal to output circuit 1405, causing output circuit 1405 to send a read request to address control 1404. Address control 1404 makes the receive buffer read pointer available, allowing output circuit 1405 to read receive buffer 1501 at the address specified by the read pointer. Output circuit 1405 reads the packet, modifies the necessary fields to convert the trunk packet into a switch packet, performs the necessary logical to physical address translation, and sends the packet to the switching network. The logical to physical address translation involves reading the logical translation table in memory 1401, and updating the required packet fields.

The packet flow of an ordinary data packet from the switch network to the trunk is as follows. The packet is received from the switching network via switch interface 1418, and is sent to input circuit 1406. Input circuit 1406 makes a write request to address control 1404, in order to write the packet into transmit buffer 1503 in memory 1401. Address control 1404 receives the write request and makes the transmit buffer write pointer available. Input circuit 1406 then writes the packet into transmit buffer 1503, at the address specified by the write pointer. Address control 1404 then sends a packet available signal to transmitter 1403, causing transmitter 1403 to send a read request to address control 1404. Address control 1404 makes the transmit buffer read pointer available, allowing transmitter 1403 to read transmit buffer 1503 at the address specified by the read pointer. Transmitter 1403 makes a read request to address controller 1404, in order to read the packet from transmit buffer 1503. Once transmitter 1403 has read the packet, it removes the header information from the packet, which transforms the packet into a trunk packet. Transmitter 1403 then transmits the packet on the attached trunk.

Trunk test packets are received by receiver 1402 from the trunk. They are written into trunk test buffer 1502 in memory 1401, using the trunk test buffer write pointer in address control 1404. This operation is similar to the operation of the receive buffer write pointer. Transmitter 1403 then makes a read request to address control 1404, in order to read trunk test buffer 1502, using the trunk test buffer read pointer. Once transmitter 1403 has read the test packet, it transmits it back to the trunk. Switch test packets are processed in a similar manner. They are received by input circuit 1406, which writes then into switch test buffer 1504 in memory 1401, using the switch test buffer write pointer. Output circuit 1405 then reads switch test buffer 1504, using the switch test buffer read pointer in address control 1404. Once it has read the packet, it sends it to the specified trunk controller via the switch network.

Memory write packets are used to write information into memory 1401. This information includes the logical to physical address translations, which are written into logical translation table 1505. Memory write packets are originated by the central processor, and are sent to input circuit 1406, which writes part of the packet into switch test buffer 1504, and part of the packet into logical translation table 1505, both located in memory 1401. The portion of the memory write packet that is written into switch test buffer 1504 is written via the switch test buffer write pointer; the portion of the packet that is written into logical translation table 1505 is written via the second input circuit temporary pointer, both located in address control 1404. Output circuit 1405 then reads the information stored in switch test buffer 1504, and reads the logical translation information. It then assembles these two portions of data into a packet that is identical to the original memory write packet, and transmits this packet back to the central processor.

Memory read packets are originated by the central processor, and are used to allow the central to read portions of memory 1401. The incoming memory read packet contains the memory address, and the

0 112 831

number of bytes to be read. Output circuit 1405 reads memory 1401 at the address specified in the packet, and inserts the number of bytes specified into the memory read packet. It then returns the packet (containing the requested data) to the central processor.

5 Trunk and switch packets are further described with respect to the fields contained in each of these two packet types. The actual packet manipulation and conversion details are described later. Trunk packets carry data and maintenance information between the trunk equipment and the trunk controllers. The format of a typical trunk packet is shown in Fig. 3. An explanation of the fields is given in the following paragraphs.

10 The flag field is a unique bit pattern (01111110) used to identify the beginning and end of a packet. The packet identifier (PID) field determines whether the packet is for signaling, testing, or the transmission of normal data. A "0" in this field indicates a signaling packet used for call set-up. As previously described, this packet is routed through all central processors along the path, in order to establish the path that all subsequent packets will take for the duration of the call.

15 A PID field of "1" indicates a signaling packet that sends signaling information over a path that has already been established. This packet type is read only at the terminating central office.

20 A PID field of "2" or "3" is a test packet, which is used to test a trunk in the network. The originating central processor sends a test packet to one of its trunk controllers, via the switching network. This packet is indicated by a PID field of "2". The packet is transmitted by the first trunk controller over the trunk to a second trunk controller. Since the PID field is a "2", the second trunk controller changes the field from a "2" to a "3" and loops the test packet back to the first trunk controller over the trunk. The first trunk controller receives the packet, and reads the PID field. Since the PID field is a "3", the first trunk controller returns the packet to the central processor.

25 A PID field of "8" through "11" identifies the packet as one carrying normal data. The ascending order of numbers indicates levels of flow control. An "8" indicates no flow control. The numbers "9" through "11" indicate increasing levels of flow control. When flow control increases, the originating office sends the packets out with a greater amount of time in between. This is to prevent system overload due to increased traffic.

30 A PID field of "12" indicates a datagram. This is a single packet that carries a complete message. A datagram is routed as follows. A datagram is created by the central processor associated with the terminal equipment sending the datagram. The datagram is then routed to each central processor in the network that the datagram passes through. Each central processor reads the logical address field of the datagram to determine the next central processor to which the datagram is sent. Once the datagram reaches the destination central processor, the destination central processor routes the datagram to the destination customer's terminal equipment. The address information is not retained because a path is not required to send additional packets.

35 The logical address field is used to derive the address of the destination trunk controller. This is done by the current trunk controller using the logical address to index logical translation table 1505 contained in memory 1401. Logical translation table 1505 contains the number of the next trunk controller and the new logical address. The current trunk controller inserts the new logical address into the packet's logical address field and then routes the packet. The time stamp field carries the accumulated time that it takes for the packet to travel through the switch system. This field is updated in conjunction with the arrival time field, which is inserted when the packet is first received from the trunk. When the destination trunk controller receives a packet, it calculates the difference between the arrival time and the present time, in order to update the time stamp field. The data field contains the actual data, or information, that the packet is to carry. In addition, this field carries certain high level protocol information. The cyclic redundancy code (CRC) field is used for error detection. This field is generated by the transmitting trunk controller, and tested by the destination trunk controller, in order to determine if the packet contains errors.

45 Switch packets carry data and maintenance information within the switching network. The format of a typical switch packet is shown in Fig. 6. A data type switch packet contains all the fields contained in a trunk packet, and in the same order. The one exception is the two flag fields, which are not contained in the switch packet. Also, the CRC field is recalculated and checked at several stages of the transformation process from trunk packets to switch packets. An explanation of the fields unique to switch packets is provided in the following paragraphs.

50 The packet length field is the total length of the packet, in bytes. This field is computed by receiver 1402. The destination trunk controller (DTC) and source trunk controller (STC) fields are used for packet routing. The DTC is the address of the destination trunk controller and is obtained from logical translation table 1505. The STC field is the address of the trunk controller that is presently handling the packet.

As given in the following Table 1, the control field, CNTL, defines the type of switch packet.

60

65

0 112 831

TABLE

Switch packet type	
Cntl.	Explanation
0	Standard data packet
1	Maintenance read packet
2	Maintenance write packet
3	Memory read packet
4	Memory write packet
5	Test packet—routed to first trunk controller
6	Test packet—routed to second trunk controller

Standard data packets carry the information contained in data type trunk packets (packet identifier of "8", "9", "10", or "11"), as well as signalling and datagram packets (packet identifier of "0", "1", or "12") through the switch network. These packets are transformed back to trunk packets by the next trunk controller in the network, and then transferred back to switch packets, as required, for transmission through subsequent switch networks. Maintenance information is transmitted through the system with maintenance write and maintenance read packets. These packets give the central processor the ability to read and write maintenance information into the trunk controller. This maintenance information includes error and control information. A maintenance write packet is generated by the central processor and is sent to the appropriate trunk controller. Once this packet arrives at the trunk controller, the trunk controller examines the control field, determines that it is a "2" (indicating a maintenance write) and writes the data portion of the packet into maintenance register 3101 in switch interface 1418.

When the trunk controller receives a switch packet with a "1" in the control field, it performs a maintenance read operation. The data in the maintenance register is read, and stored in the data portion of a packet. The packet is then transmitted to the originating central processor.

Switch packets are also used to read and write the memory portion of the trunk controller. In a memory write operation, the switch packet's control field is a "3". Input circuit 1406 receives the packet from the central processor, writes the data portion into the requested location in memory 1401, and writes the rest of the packet into switch test buffer 1504. Output circuit 1405 reads the data from the specified location in memory 1401, and reads the remainder of the packet from switch test buffer 1504. It then assembles a new packet from these two segments, and transmits the new packet back to central processor 115 via switching network 116.

A test packet is a type of switch packet that can route test data through two trunk controllers, before routing the packet back to the central processor. When the test packet arrives at the first trunk controller, the control field is set to "5". This indicates that the packet is to be routed to a second trunk controller before being returned to the central processor. Before leaving the first trunk controller, output circuit 1405 changes the control field from a "5" to a "6", and then sends the packet to the second trunk controller. The address of the second trunk controller is specified in the data field. After the second trunk controller receives the test packet, it reads the control field. Since the field is a "6", the second trunk controller routes the packet directly to the central processor.

The main function of receiver 1402 is to convert trunk packets, received from the trunk side of the network, into switch packets, which are then transmitted through the switching part of the network. The conversion consists of (1) removing the start and end flag fields, and (2) adding fields at the beginning of the packet. The transformation also requires that the CRC field be recalculated. The added fields are as follows. The first two added fields, destination trunk controller and source trunk controller are filled with zeroes. The actual source and destination trunk controller values are added by output circuit 1405 after it reads the packet from receive buffer 1501. The next added field is the control field. The last added field is the arrival time field. This field is filled in with the actual time that the packet arrives at receiver 1402, and is used by the destination trunk controller to update the time stamp field.

During packet conversion, the destination trunk controller, source trunk controller and control fields are initialized to zero. The arrival time field is initialized to the arrival time of the packet (expressed as a negative number). The packet identifier field is unchanged, with one exception: if the packet identifier field of the incoming packet is a "2", indicating a test packet, it is changed to a "3", indicating a trunk test packet that is returning. As already mentioned, the CRC field is updated; however, the updating process has this

complication: the CRC field is computed as though the packet length field contained all zeros, and the actual length of the packet was contained in a separate field between the data and CRC fields. The reason for this is because the length of the packet is being computed as the packet comes in, and is not known until the entire packet is received.

5 Receiver 1402 is shown in greater detail in Fig. 16. Receiver 1402 comprises flag removal and bit unstuffing circuit 1601, packet reformatter 1602, and serial to parallel converter 1603. Flag removal and bit unstuffing circuit 1601 removes the 01111110 flag pattern at the beginning and end of the trunk packet.

10 Additionally, this circuit removes bits that were stuffed into the bit stream by transmitter 1403. This process is explained later. Packet reformatter 1602 adds zeroes to the packet. These zeroes serve as place holders for the fields added during the packet transformation. In addition, this circuit fills in the arrival time of the packet, and updates the packet identifier field, as required.

The trunk packets are received by flag removal and bit unstuffing circuit 1601 on conductor 1604. This circuit detects the start and end points of each packet by detecting the presence of the start and stop flags contained in the packet. Once the flags are detected, they are removed. In addition, this circuit performs bit 15 unstuffing. Bit unstuffing is the removal of bits that were placed in the bit stream to ensure that the flag pattern does not occur at any place other than the start and end of the packet.

20 Flag removal and bit unstuffing circuit 1601 sends the packets to packet reformatter 1602 via conductor 1605. A signal is placed on conductor 1606 when the packet first arrives at packet reformatter 1602. This signal remains as long as the packet is being processed. A similar signal is present on conductor 1609 during the time that the packet is being transferred from packet reformatter 1602 to serial to parallel converter 1603. A "1" is placed on conductor 1607 during every clock pulse that conductor 1605 contains data. Packet reformatter 1602 receives the trunk packet from 1601 and adds the appropriate fields to allow the forming of a switch packet. In addition, this circuit performs error detection, and modifies the PID field as required.

25 Error detection is done by checking the CRC field of each incoming packet. If an error is detected, 1602 transmits an error signal to 1603 via conductor 1612, which causes the packet containing the error to be aborted. Packet reformatter 1602 also detects hardware errors. If a hardware error is found, it is indicated by a signal on conductor 1626.

30 The PID field modification performed by 1602 is with respect to trunk test packets. An incoming test packet has a PID of "2"; 1602 changes the field to a "3". Additionally, when a test packet is received, 1602 causes conductor 1611 to go high. This causes serial to parallel converter 1603 to write the contents of the test packet into trunk test buffer 1502. Packet reformatter 1602 is fully duplicated and thus is capable of doing fault detection of itself.

35 Flag removal and bit unstuffing circuit 1601 is shown in greater detail in Fig. 17. This circuit does flag removal and bit unstuffing. Flag removal is performed as follows. A flag pattern of 01111110 is continuously sent over conductor 1604 whenever the trunk is idle. This 8-bit pattern is read into register 1701. At the same time that register 1701 is receiving the bit pattern, register 1702 is receiving a steady stream of "1's" at the same bit rate. After a complete 8-bit flag pattern is received, register 1702 is cleared via a "1" on the output of AND gate 1706, which decodes the presence of the flag pattern. This prevents the 40 "1's", which are being clocked into register 1702, from being sent out of register 1702. The "1's" coming out of register 1702 are routed to AND gate 1714 and register 1705. When "1's" are present, actual data is allowed to flow out of register 1701, and conductor 1607 is activated to signal this actual data.

45 After a flag pattern from an actual packet is clocked into register 1701, the subsequent bits are actual packet contents rather than the flag pattern. After eight bits of actual data have been clocked into register 1701, AND gate 1706 does not clear register 1702 because the AND gate is not detecting the flag pattern. This causes register 1702 to send a continuous stream of "1's" to one input of AND gate 1714. The other input of AND gate 1714 is receiving the actual packet contents from register 1701. AND gate 1714 is thus enabled by the "1's" coming out of register 1702. Because of the enable signal, the contents of register 1701 are allowed to be shifted into register 1703. Thus, the output of AND gate 1714 is "1" only when the 50 actual packet contents contain a "1". In this way, the packet contents minus the flags are shifted through register 1703 and are sent to packet reformatter 1602 via conductor 1710.

Bit unstuffing is required because whenever transmitter 1403 detects five sequential "1's", it always stuffs a "0". This is so that the packet data never contains the flag pattern. These stuffed zeros are removed by flag removal and bit unstuffing circuit 1601 after the flags have been removed. Bit unstuffing is done as 55 follows. The packet data coming out of AND gate 1714 still contains the stuffed "0's". If a pattern of 11111 is clocked into register 1703, the next bit has to be a stuffed bit, which must be removed. This 11111 pattern causes the output of NAND gate 1718 to go to "0" during the one bit time that the stuffed "0" is in the first position of register 1703. This "0" is shifted through register 1704 at the same time that the actual packet data is shifted through register 1703. When the "0" in register 1704 reaches the input of AND gate 1708, 60 conductor 1606 goes to "0" for that one clock pulse that the stuffed "0" is present in register 1703. Conductor 1606 is the bit present indicator, which is passed to packet reformatter 1602. Since the bit present signal is absent for any clock pulse that a stuffed "0" is contained in register 1703, the stuffed "0" is removed.

65 Packet reformatter 1602 is shown in greater detail in Fig. 18. This circuit performs the actual packet transformation. This circuit comprises CRC circuits 1801 and 1804, packet reformat circuits 1802 and 1805,

and comparator 1803. The CRC and packet reformat circuits are duplicated because during the reformatting process the CRC check cannot accurately detect errors within the circuit. The CRC circuits check the CRC field of the incoming packet and then remove it. The packet reformat circuits do the actual packet transformations and calculate the new CRC field. Comparator 1803 compares the reformatted packets from packet reformat circuits 1802 and 1805. If the packets do not match, a fault is present in the packet, and is indicated by a FLTR signal on conductor 1626. This FLTR signal is sent to switch interface 1418, and then to the central processor, which then takes corrective action.

Packet reformat circuit 1802 is shown in greater detail in Fig. 19. This circuit comprises pad circuit 1901, which adds blank fields to the incoming trunk packet to be used to form a switch packet by later circuits; arrival time circuit 1902, which calculates and fills in the packet arrival time; PID circuit 1903, which updates the PID field if required; length circuit 1904, which calculates and fills in the packet length; and CRC circuit 1905, which calculates the CRC field of the packet.

Pad circuit 1901 is shown in greater detail in Fig. 20. This circuit pads 56 zeroes at the beginning of the incoming packet, and pads 24 zeroes at the end of the packet. These zeroes serve as place holders for the fields that are added by the succeeding circuits. Pad circuit 1901 receives both psi and phi clock pulses from system clock 161. The phi pulses are five times faster than the psi pulses, as shown in Fig. 54. The phi clock pulses are required to place the zeroes at the beginning of the packet.

Pad circuit 1901 receives data, data present, and bit present signals on conductors 1814, 1815, and 1816. These signals pass through operated AND gates 2006 through 2008, and are shifted into registers 2001 through 2003. Registers 2001 through 2003 shift data through at the psi clock rate through operated AND gate 2010 and OR gate 2011. The first pulse on conductor 1815 activates control 2004 via conductor 2031. When control 2004 is activated, it activates counter 2005, and pad conductor 2027. Conductor 2027 pads 56 zeroes to the beginning of the packet via AND gate 2019 and flip-flop 2024. Counter 2005 counts the clock pulses and signals control 2004 via AND gate 2030 to disable conductor 2027 after 56 pulses. The zeroes are padded at the phi clock rate; this allows the zeroes to be padded at the beginning of the packet before the actual packet data is shifted out of register 2001. When the data, data present and bit present signals are shifted out of registers 2001 through 2003 they are converted from 1.544 to 8 Mb/s, via gates 2013, 2014, 2016, and 2034, and flip-flop 2015. When the last 16 bits of the packet are in register 2001 (signalled by conductor 2031 being disabled), control 2004 activates conductor 2032. This causes the last 16 bits in registers 2001 through 2003 to be shifted through at the phi clock rate, via operated AND gate 2012 and OR gate 2011. Additionally, this signal disables AND gates 2006 through 2008, via inverter 2009. The purpose of this is to prevent the next packet from being shifted into pad circuit 1901 until the existing packet is shifted through. After the end of the packet is shifted out of register 2001, control 2004 enables conductor 2027 for 24 clock pulses, causing 24 zeroes to be padded to the end of the packet.

Arrival time circuit 1902 is shown in greater detail in Fig. 21. This circuit places the arrival time of the packet into the arrival time field. The arrival time is calculated as a negative, rather than positive, value. By running the clock in reverse, the arrival time can be added to the present time, avoiding the need to complement, as described later in the description of transmitter 1403. Arrival time circuit 1902 comprises counters 2101 and 2103, shift register 2102, control 2104, and flip-flops 2109 through 2111. Counter 2101 maintains the current time through external tick and sync pulses from system clock 161. Counter 2103 counts the number of bits in the incoming packet in order to determine where the arrival time field is. When a packet arrives, it is indicated by a signal on conductor 1907; this signal is sent to control 2104 via conductor 2105. When control 2104 receives this data present signal, it signals counter 2103, via conductor 2113, to begin counting incoming bits. Additionally, control 2104 places a signal on conductor 2112. This signal causes the contents of counter 2101 to be loaded into shift register 2102. The effect of this is to load the arrival time of the packet into shift register 2102. The arrival time field is in bit positions 48 through 55 of the packet. This field had been previously filled with zeroes by pad circuit 1901. When counter 2103 reaches 48, it signals control 2104 via AND gate 2118. Control 2104 then places a signal on the input of AND gate 2115, causing AND gate 2115 to operate. When AND gate 2115 operates, it causes shift register 2102 to shift its contents out to flip-flop 2109, via AND gate 2116 and OR gate 2117. Flip-flops 2109 through 2111 then transmit the information received on their D inputs onto conductors 1909 through 1911, at the phi clock rate.

PID circuit 1903 is shown in greater detail in Fig. 22. PID circuit 1903 reads the PID field of incoming packets and determines the packet type. If the incoming packet is a datagram, a signal is placed on conductor 1918. If the incoming packet is a test packet, a "3" is placed in the PID field, and a signal is placed on conductor 1611. An incoming packet arrives on conductor 1909. Conductor 1910 receives a steady stream of "1's" as long as the packet is being received. Conductor 1911 receives a "1" during each bit time that a valid bit is present on conductor 1909. The first "1" on conductor 1910 causes counter 2203 to count valid data bits by counting the bits on conductor 1911, through AND gate 2204. When counter 2203 reaches 59, it operates AND gate 2213, which signals control 2205. Control 2205 then places an enable signal on conductor 2214. During this 59th bit time, the least significant bit of the PID field is on conductor 1909, and the three most significant bits of the PID field are stored in shift register 2201. The data on conductor 1909 and in shift register 2201 operates either AND gate 2207 or 2206. If the data is a binary "12", indicating a datagram, AND gate 2206 operates, causing a signal to be placed on conductor 1918. If the data on conductor 1909 and in shift register 2201 are a binary "2" or "3" indicating a test packet, AND gate 2207

operates, causing a "3" to be placed in the packet identifier field. If the data on conductor 1909 and in shift register 2201 are a binary "2", AND gate 2209 is also operated, resulting in the packet being stored in trunk test buffer 1502. Flip-flops 2210 through 2212 keep the output data on conductors 1912 through 1914 in sync, via clock pulses from system clock 161.

5 Length circuit 1904 is shown in greater detail in Fig. 23. Length circuit 1904 counts the number of bytes in incoming packets, and places the byte count at the end of the packet. Additionally, length circuit 1904 places a length error signal on conductor 1919 if the packet received exceeds 150 bytes. Incoming data, data present indication, and bit present indications are received on conductors 1912 through 1914, and are shifted into shift registers 2301 through 2303. When data first appears on conductor 1912, "1's" also appear
10 on conductor 1913, indicating that data is present. The first "1" on conductor 1913 causes control 2307 to start counter 2304, via OR gate 2310. Counter 2304 counts the incoming bit present signals on conductor 2315, in order to determine the number of bytes in the packet. When conductor 1913 goes to "0", the entire packet has been counted by counter 2304. The "0" on conductor 1913 causes the contents of counter 2304 to be loaded into shift register 2305. This is done by control 2307 placing a load signal on conductor 2316.
15 One bit time later control 2307 enables shift conductor 2317, causing the contents of shift register 2305 (that is, the byte count) to be shifted into the packet through AND gate 2311 and OR gate 2318. This places the length count of the packet at the end of the packet. When control 2307 enables shift conductor 2317, it also enables counter 2306. When counter 2306 reaches eight, it signals control 2307, which disables shift conductor 2317. When counter 2306 reaches 24, the entire packet has been shifted through length circuit
20 1904. Packets longer than 150 bytes exceed the maximum packet length. These excessively long packets are detected by comparator 2308, which indicates them by placing a signal on length error conductor 1919. This length error indication causes the packets to be discarded. Flip-flops 2312 through 2314 perform the same function as flip flops 2210 through 2212 in PID circuit 1903.

Serial to parallel converter circuit 1603 is shown in greater detail in Fig. 24. Serial to parallel converter
25 1603 comprises buffer 2401 and address control interface 2402. Buffer 2401 receives data, data present and bit present indications from packet reformatter 1602. Buffer 2401 transforms the incoming data into bytes, and sends the bytes to address control 1404 via cable 2720. Address control interface 2402 signals where the information on cable 2720 is to be written by signals on conductors 2721 through 2727. Conductors 2721 through 2723 are write commands for receive buffer 1501, trunk test buffer 1502, and the temporary
30 pointer, respectively. Conductors 2726 and 2727 set the temporary pointer equal to either the receive buffer or trunk test buffer write pointers, and conductors 2724 and 2725 set the receive buffer or trunk test buffer write pointers equal to the temporary pointer.

Buffer 2401 is shown in greater detail in Fig. 25. Buffer 2401 performs the actual serial to parallel conversion. Incoming data, data present indications, and bit present indications are received on conductors
35 1608, 1609, and 1610. The incoming data is buffered by shift registers 2501 and 2504, the data present indication is buffered by shift registers 2502 and 2505, and the bit present indications are buffered by shift registers 2503 and 2506. As data bits are shifted through register 2504, they are assembled into bytes by shift register 2507. Counter 2509 counts the incoming bit present signals to determine when a complete byte has been assembled. When a byte has been assembled, the byte is loaded into output register 2508,
40 via a signal from AND gate 2510. Additionally, AND gates 2510 and 2511 set flip-flop 2512, which puts a data present signal on conductor 2404. This data present signal is an indication to address control interface 2402 that a byte is ready to be sent. After the byte has been sent, address control interface 2402 places a signal on conductor 2403 to acknowledge receipt of the byte. This signal resets flip-flop 2512.

Address control interface 2402 is shown in greater detail in Fig. 26. Address control interface 2402
45 controls the writing of receive buffer 1501 and trunk test buffer 1502, located in memory 1401. Flip-flop 2605 controls the discarding of packets that contain errors, or that must be discarded because a buffer has overflowed. Flip-flop 2608 selects whether data will be written into receive buffer 1501 or trunk test buffer 1502. Buffer 2401 indicates that it has assembled a byte by placing a signal on conductor 2404. This signal causes control 2601 to set flip-flop 2605 to "1", via a signal on conductor 2631. When flip-flop 2605 is set to
50 "1", AND gate 2610 operates, which operates AND gates 2611, 2612, 2614, and 2615. If buffer 2401 is transmitting a test packet, packet reformatter 1602 places a signal on conductor 1611. This signal sets flip-flop 2608, which causes AND gates 2622 through 2625 to operate. This action causes the packets to be written into trunk test buffer 1502. If the packet in buffer 2401 is not a test packet, flip-flop 2608 is reset to "0". This operates AND gates 2616 through 2619, via inverter 2621. When these AND gates operate, packets
55 are written into receive buffer 1501.

Address control 1404 is shown in greater detail in Fig. 27. Address control 1404 is used to allow transmitter 1403, receiver 1402, input circuit 1406 and output circuit 1405 to read and write the appropriate
60 portions of memory 1401. Address control 1404 consists of receive interface 2701, output interface 2703, transmit interface 2711, input interface 2713, and memory interface 2702. Additionally, the circuit contains full/empty circuits 2704, 2707, 2708, and 2712; as well as flip-flops 2705, 2706, 2709, and 2710. Timer 2714 controls when receiver 1402, transmitter 1403, output circuit 1405 and input circuit 1406 can access the buffers in memory 1401, by sequentially enabling conductors 2760 through 2763. The full/empty circuits are used to detect buffer overflow and empty conditions; the flip-flops are used to indicate when data is present in the respective buffers. Address control 1402 operates at the theta clock rate from system clock
65 161.

0 112 831

Receive interface 2701 receives write requests from receiver 1402 on conductors 2721 through 2727; it receives the data from receiver 1402 on cable 2720. Receive interface 2701 responds to these write requests by making either the receive buffer write pointer, trunk test buffer write pointer, or temporary pointer available for writing the data into memory 1401. For example, a signal on conductor 2722 causes receive
5 interface 2701 to write the data into receive buffer 1501, at the address pointed to by the receive buffer write pointer. After the data has been written, the receive buffer write pointer is incremented; this new address and the address plus one are sent to receive buffer full/empty circuit 2704. When receive buffer full/empty circuit 2704 detects that receive buffer 1501 is empty, it resets flip-flop 2705, causing the data present signal to be removed from conductor 2738. If receive buffer full/empty circuit 2704 detects that receive buffer 1501
10 is overfilled, it sends an overload in receive buffer indication on conductor 2728. A signal on conductor 2722 causes the data on cable 2720 to be written into trunk test buffer 1502. The circuit action is similar to that of writing receive buffer 1501, except that trunk test buffer full/empty circuit 2707 resets flip-flop 2706 when trunk test buffer 1502 is empty, and it indicates that trunk test buffer 1502 is overfilled via a signal on conductor 2729.

15 The temporary pointer is used for writing the packet length into the length field, and for aborting packets that contain errors. The temporary pointer must be used to write the length because the length field is at the beginning of the packet, and the actual length of the packet is not known until most of the packet has been written into the buffer. The actual length is inserted into the packet in the following manner. The temporary pointer is set equal to the write pointer, and the write pointer starts to write the packet into the
20 buffer. When the packet length (which had been placed near the end of the packet) is ready to be written, it is written using the temporary pointer. Since the temporary pointer had been set equal to the write pointer, it is pointing to the location of the length field. In this way, the actual packet length is written into the length field of the packet.

If an error is detected in the packet, the packet is aborted. This is accomplished by receiver 1402 pulsing
25 conductor 2724, which directs receive interface 2701 to set the write pointer for the receive buffer equal to the temporary pointer.

Output interface 2703 receives read requests from output circuit 1405 via conductors 2732 through 2736.

Output interface 2703 responds to these read requests by making the appropriate pointer available to
30 read data from memory 1401. For example, a signal on conductor 2732 causes output interface 2703 to read the data from receive buffer 1501 at the address pointed to by the receive buffer read pointer. A signal on conductor 2733 causes output interface 2703 to read switch test buffer 1504 at the address pointed to by the switch test buffer read pointer. Once output interface 2703 has read the data, it forwards the data to output circuit 1405 via cable 2731.

35 Overflow conditions are detected by receive buffer full/empty circuit 2704. This is done by 2704 comparing the read pointer against the write pointer plus one. If these two are equal, it indicates that an overflow will occur if the receiver attempts to write another byte into receive buffer 1501.

The operation of input interface 2713 is similar to receive interface 2701. Incoming data is received
40 from input circuit 1406 via cable 2744, and is written into either transmit buffer 1503 or switch test buffer 1504. The write requests from input circuit 1406 are via conductors 2745 through 2752, and conductor 2765. Switch test buffer full/empty circuit 2708 and transmit buffer full/empty circuit 2712 receive write pointer addresses from input interface 2713, in order to maintain the full/empty status of switch test buffer 1504 and transmit buffer 1503. These full/empty circuits reset flip-flops 2709 and 2710, and send buffer overfilled conditions via conductors 2742 and 2743. The operation of transmit interface 2711 is similar to output
45 interface 2703. Data is read from either transmit buffer 1503 or trunk test buffer 1502 in memory 1401. Once the data has been read, it is sent to transmitter 1403 via cable 2755. Read requests are received from transmitter 1403 via conductors 2753 and 2754. Transmit interface 2711 contains no temporary pointers.

Memory 1401 contains the following circular buffers: receive buffer 1501, trunk test buffer 1502,
50 transmit buffer 1503, and switch test buffer 1504. A circular buffer is shown in detail in Fig. 28. Circular buffers allow read pointer 2801 and write pointer 2804 to continuously read and write the same portion of memory 1401, as long as read pointer 2801 is always ahead of write pointer 2804, so that write pointer 2804 cannot write a portion of memory 1401 that has not yet been read. After each read or write operation, the appropriate pointer (read or write) is incremented by one. If write pointer 2804 is at a location one less than
55 read pointer 2801, the buffer is full (that is, the next write operation will overwrite a portion of the buffer that read pointer 2801 has not yet read). When the condition occurs, full/empty circuit 2803 indicates a full buffer condition on conductor 2808. Similarly, when read pointer 2801 is at a location one less than write pointer 2804, the buffer is empty.

Temporary pointers are used by receiver 1402, input circuit 1406, and output circuit 1405 for various
60 applications. In the receive circuit, for example, the temporary pointer is used to back-up the write pointer, in cases where the write pointer has written a packet and then receiver 1402 discovers an error. The temporary pointer points to the memory location containing the first byte of the packet. By setting the write pointer equal to the temporary pointer, the packet is effectively aborted.

A typical pointer is shown in Fig. 29. Pointers contain the address of the current position in the buffer in
65 order to read or write the buffer. The pointer circuit does the following: resets the pointer; increments the pointer (including wrap-around); loads the pointer from an external source, for example, setting the read

0 112 831

pointer equal to the temporary pointer; and provides the current address, and the address plus one, for use by the full/empty circuit. The current address is stored in register 2901. This address is available on cable 2919; the address plus one is available on cable 2921. A reset operation causes the start address on conductor 2920 to be loaded into register 2901, as follows. The reset is initiated by a signal on conductor 2915. This signal enables register 2901 via OR gate 2902. Additionally, this reset signal operates OR gate 2909, which enables AND gate 2913. The start address on cable 2920 passes through AND gate 2913 and OR gate 2912 to one input of AND gate 2905. The other input of AND gate 2905 is enabled via inverter 2906; thus, the start address is loaded into register 2901. Incrementing the pointer causes the pointer to read or write the next memory address. When the pointer has reached the limit address, incrementing causes wrap around. Incrementing is initiated by a signal on conductor 2916. This signal enables register 2901 via OR gate 2902. The address that is loaded into register 2901 depends on whether or not the limit of memory space has been reached. If the limit has not been reached, comparator 2907 operates, which operates AND gate 2911 and OR gate 2912. When OR gate 2912 operates, the current address plus one is loaded into register 2901 via AND gate 2905 and OR gate 2904. If the limit has been reached, comparator 2908 operates. This operates OR gate 2909, which causes the start address on conductor 2920 to be loaded into register 2901 as previously described. This is the wrap around. Loading from an external source is initiated by a signal on conductor 2917. This signal enables register 2901 via OR gate 2902; additionally, this signal enables AND gate 2903 and disables AND gate 2905 via inverter 2906. When AND gate 2903 is enabled, the external address on cable 2918 is put in register 2901, via OR gate 2904.

Receive interface 2701 is shown in greater detail in Fig. 30. Receive interface 2701 comprises receive buffer write pointer 3001, temporary pointer 3002, and trunk test buffer pointer 3003. These pointers are similar to the pointer described in Fig. 29 and are used to allow receiver 1402 to read receive buffer 1501 and trunk test buffer 1502. Data is received from buffer 2401 on cable 2720, and is written, via cable 3004, into memory 1401 via memory interface 2702. The memory location is specified via address cable 3006. This address is received from the DO lead of the respective pointer 3001, 3002, or 3003) through OR gate 3015 and AND gate 3011. AND gates 3009 through 3011 are multi-input AND gates that send data, write indications, and addresses to memory 1401 via cables 3004 through 3006. Output interface 2703, input interface 2713, and transmit interface 2711 are similar in design to receive interface 2701.

Switch interface 1418 is shown in greater detail in Fig. 31. This circuit is the interface between trunk controller 131 and switching network 116. Its primary function is to provide maintenance read and write capabilities between the trunk controller and central processor 115. These maintenance functions are provided via maintenance read and write packets, and via fault detection circuit 3108. Maintenance information is sent between switch interface 1418 and the central processor via maintenance read and maintenance write packets. Packets are sent to input control 3107 via conductor 132. Input control 3107 reads the control field of the packet to determine whether the packet is a maintenance packet. If the packet is not a maintenance packet, it is shifted through to input circuit 1406. If the packet is a maintenance packet, it is shifted through to maintenance control 3102.

Maintenance control 3102 reads the control field of the incoming packet to determine whether the packet is a maintenance read or maintenance write packet. If it is a maintenance write packet, the information from the packet is passed through register 3103 to maintenance register 3101. This operation is controlled by maintenance control 3102. The maintenance information is then passed back to register 3103, and transmitted back to the central processor as a check to verify that the information was correctly written and stored in maintenance register 3101. If it is a maintenance read packet, the information stored in maintenance register 3101 is read into register 3103, and is then transmitted to the central processor. Before the packet is transmitted back to the central processor, the source and destination fields of the packet must be switched, and the CRC code must be recalculated. These functions are accomplished by packet reformatter 3104.

Another maintenance function consists of fault detection circuit 3108 and cables 3110 through 3113. Cables 3110 through 3113 are connected to receiver 1402, transmitter 1403, input circuit 1405, and output circuit 1405, respectively. These cables transmit faults, such as memory error or packet received in error, to fault detection circuit 3108.

Input circuit 1406 is shown in greater detail in Fig. 32. This circuit receives switch packets from switching network 116 via switch interface 1418 and writes the packets into the appropriate portions of memory 1401. Input circuit 1406 comprises packet reformatter 3201 and serial to parallel converter 3202. Incoming packets are received from switch interface 1418 on conductor 3203, with data present indication on conductor 3204. Packet reformatter 3201 reads the control field of the incoming packet to determine the packet type. If it is a memory write packet, it is indicated by a signal on conductor 3212. If it is a test packet, it is indicated by a signal on conductor 3210. Packet reformatter 3201 also updates the length and CRC fields of memory write packets. After packet reformatting has been done, the packet is passed in serial to serial to parallel converter 3202. Serial to parallel converter 3202 converts this incoming serial stream to bytes, and controls the transfer of these bytes to memory. In the case of an ordinary data packet, the data is written into transmit buffer 1503, via a signal on conductor 2745. In the case of a test packet, the data is written into switch test buffer 1504, via a signal on conductor 2746. In the case of a memory write packet, the data is written into the memory location specified in the packet itself. Conductors 2747 through 2752, and conductor 2765 control the writing and setting of the two temporary pointers. Temporary pointer 1 is used

for aborting packets found in error; temporary pointer 2 is used for writing the data portion of memory write packets into the specified memory location.

Packet reformatter 3201 is shown in greater detail in Fig. 33. Packet reformatter 3201 contains duplicated CRC circuits 3301 and 3303, duplicated packet reformat circuits 3302 and 3304, and comparator 5 3305. The duplicated circuitry is required because the CRC code cannot detect errors during the reformatting process. Incoming packets are received by packet reformatter 3201 on conductor 3203. CRC circuits 3301 and 3303 check the CRC field of the incoming packet. If both CRC circuits detect an error, a packet received in error signal is generated by AND gate 3306 and sent to switch interface 1418 via conductor 3206. Additionally, a packet received in error causes a signal to be placed on conductor 3211. 10 This signal causes serial to parallel converter 3202 to discard the packet. Packets not found in error are then reformatted by packet reformat circuits 3302 and 3304. This reformatting process involves updating the control, length, and CRC fields. If there is a mismatch in the reformatting done by packet reformat circuits 3302 and 3304, the mismatch is detected by comparator 3305. This mismatch causes comparator 3305 to send a fault indication to switch interface 1418 via conductor 3205.

15 Packet reformat circuit 3302 is shown in greater detail in Fig. 34. Packet reformat circuit 3302 comprises format control 3401, format length circuit 3402, and format CRC circuit 3403. Packet reformat circuit 3302 updates the control, length, and CRC fields of memory write packets only; all other packets are passed through the circuit with no changes. Format control 3401 receives packets from CRC circuit 3301 via conductor 3307. A signal is placed on conductor 3308 to indicate that data is present on conductor 3307. 20 This data present signal is passed to format length circuit 3402 via conductor 3405, and to format CRC circuit 3403 via conductor 3408. Format control 3401 examines the control field of the incoming packet. If the field is a "4" (indicating a memory write packet), format control 3401 places a signal on conductor 3212, which activates format length circuit 3402 and CRC circuit 3403. If the incoming packet is not a memory write, format control 3401 shifts the packet through. If the packet is a test packet, format control 3401 25 indicates this by placing a signal on conductor 3210, which results in the packet being written into switch test buffer 1504. If format control 3401 receives a memory write packet, format length circuit 3402, in response to the memory write packet signal from conductor 3212, inserts a constant length into the length field, and CRC circuit 3403 calculates a new CRC. A constant length is written into the length field because the memory write packets written into switch test buffer 1504 contain the packet header fields only, without 30 the data, and thus are the same length. The reformatted packet is then forwarded to serial to parallel converter 3202 via conductor 3208.

Format control 3401 is shown in greater detail in Fig. 35. Format control 3401 reads the control field of the incoming packet. If the incoming packet is a memory write packet, a signal is placed on conductor 3212; 35 if the incoming packet is anything but a normal data packet, a signal is placed on conductor 3210. The packet enters on conductor 3307 and is shifted through register 3501 into 3502 at the phi clock rate from system clock 161. This is done to capture the control field in register 3501. At the same time, the data present signal is shifted into register 3503. When 48 bits of the packet have been shifted into registers 3501 and 3502, register 3501 contains the control field, bits 40 through 48. The value in the control field is sent to comparators 3504 and 3505, via conductor 3510. Comparators 3504 and 3505 lead the control field to 40 determine the packet type. If the control field is a "4" (indicating a memory write packet), comparator 3504 operates and places a signal on conductor 3212 via AND gates 3508 and 3510. If the control field is not equal to "0", comparator 3505 operates and places a signal on conductor 3210 via AND gates 3509. Flip-flops 3506 and 3507 ensure that the data and data present signals are clocked at the phi rate.

Format length circuit 3402 is shown in greater detail in Fig. 36. Format length circuit 3402 places a 45 constant length into the length field of memory write packets. All other packets are shifted through with no action taken. Incoming data and data present signals arrive on conductors 3404 and 3405. If the incoming packet is not a memory write packet, the data is shifted through flip-flop 3601, gates 3608 and 3609, and flip flop 3607. The data present signals are shifted through via flip-flops 3602 and 3611. All flip-flops operate at the phi clock speed under control of system clock 161. If the incoming packet is a memory write packet, it is 50 indicated by a signal on conductor 3212. This memory write signal sets flip-flop 3605. When flip-flop 3605 is set, and the first bit of the packet is about to be shifted into flip-flop 3601, flip-flop 3604 is set, causing the constant "18" to be shifted into the length field of the packet from shift register 3606 and through AND gate 3610 and OR gate 3609. At the same time, counter 3603 is enabled. When counter 3603 reaches "7", flip-flop 3604 is reset, and shift register 3606 stops shifting. The remainder of the packet is then shifted 55 through AND gate 3608 and OR gate 3609.

Format CRC circuit 3403 is shown in greater detail in Fig. 37. Format CRC circuit 3403 recalculates the CRC field of memory write packets. All other packets are shifted through with no action taken. The incoming data present signal on conductor 3408 causes control 3704 to activate counter 3703. Counter 3703 counts the bits of the incoming packet as they appear on conductor 3407, and are passed through flip-flop 60 3701, data selector 3706, and flip-flop 3707. As the data passes through the circuit, it is also sent to CRC circuit 3705, which is calculating the new CRC. When counter 3703 reaches 128, it signals control 3704, which disables CRC circuit 3705. This is done because the first 128 bits of the packet contain the packet header, which is the only part of the packet that the CRC must be calculated. After bit 128, the rest of the packet contains the data. This data gets written into memory, and does not appear in the packet when the 65 packet is transmitted. Thus, the CRC field is not calculated over the data portion of the packet, since the data

is written into logical translation table 1505. When the end of the packet leaves data selector 3706, control 3704 shifts the recalculated CRC field through data selector 3706 and, thus, onto the end of the packet.

Serial to parallel converter 3202 is shown in greater detail in Fig. 38. Serial to parallel converter 3202 comprises buffer 3801 and address control interface 3802. Buffer 3801 receives incoming serial information on conductor 3208 and transforms the information into bytes, which are sent to address control 1404 via cable 2744. Address control interface 3802 signals to address control 1404 where in memory 1401 the data is to be written. This signalling is provided via conductors 2745 through 2752, and conductor 2765. The signalling is done in a manner similar to receive address control interface circuit 2402.

Buffer 3801 is shown in greater detail in Fig. 39. Buffer 3801 forms the incoming serial data into bytes. Additionally, it signals address control interface 3802 when the CRC field is in the buffer. This is necessary because, in a memory write packet, address control interface 3802 writes the CRC field into switch test buffer 1504 and writes the data portion of the packet into a different memory location. Incoming data and data present signals appear on conductors 3208 and 3209, and are shifted into registers 3901 and 3902. When a byte has been assembled in register 3903, it is loaded into register 3904 and sent to address control 1404 via cable 2744. A signal on conductor 3805 indicates to address control interface 3802 that the CRC field is ready to be transmitted. With the previously noted differences, the operation of buffer 3801 is similar to the operation of buffer 2401.

Address control interface 3802 is shown in Fig. 40. Address control interface 3802 allows packets similar to those shown in Fig. 6 to be written into memory 1401. The packet can be either a data, memory read, or switch test packet. In the case of a data packet, the packet is written into transmit buffer 1503 in memory 1401. When the first byte is ready in buffer 3801, it is indicated by a signal on conductor 3804. This signal causes control 4028 to place a signal on conductor 4030. This signal sets flip-flop 4013, which places a "1" on the output of AND gate 4012. Control 4028 then places a signal on conductor 4035. This is a write buffer command. In the case of a data packet, the data is written into transmit buffer 1503 because the signal on conductor 4035 operates AND gate 4016, which operates AND gate 4017. When AND gate 4017 operates, a signal is placed on conductor 2745. This signal is passed to address control 1404, and it causes the byte contained in buffer 3801 to be written into transmit buffer 1503 in memory 1401. This process continues until the entire packet has been read from buffer 3801 and has been written into transmit buffer 1503. After each byte has been transferred from buffer 3801 into transmit buffer 1503, control 4028 sends an acknowledge signal to buffer 3801 via conductor 3803. The operation for a test packet is similar as that for a data packet, with the exception that the packet is written into switch test buffer 1504, rather than into transmit buffer 1503. This is accomplished by the test packet signal on conductor 3210 setting flip-flop 4005. When flip-flop 4005 is set, AND gates 4017 through 4021 are disabled, and AND gates 4023 through 4027 are enabled. This allows the writing of switch test buffer 1504 while disabling the writing of transmit buffer 1503. A memory write packet requires that the packet length, destination and source trunk controller, control, arrival time, process identifier, logical address, time stamp, and CRC fields be written into switch test buffer 1504; and that the data field be written into another memory location specified in the packet. To do this, control 4028 activates the writing of switch test buffer 1504 during the writing of most of the packet. This causes the beginning fields, up to the data field, to be written into switch test buffer 1504 via conductor 2746. When the data portion of the packet is to be written, control 4028 disables the writing of switch test buffer 1504, and enables the writing of temporary pointer 2, causing the data portion of the packet to be written into the memory location to which temporary pointer 2 is pointing via conductor 2747. After the data portion is written, control 4028 causes the CRC field to be written into switch test buffer 1504, via conductor 2746.

If a packet stored in buffer 3801 contains errors, or if the buffer that the packet is being written into is overfilled, then the packet must be discarded. Packets that contain errors are indicated by a signal on conductor 3211. An overload of transmit buffer 1503 is indicated by a signal on conductor 2743, and an overload of switch test buffer 1504 is indicated by a signal on conductor 2742. The discarding of a packet is done by temporary pointer 1, which is set equal to the write pointer at the start of the write operation. If an error is found or a buffer is overfilled, the write pointer is set equal to temporary pointer, via a signal on conductor 2748 or 2765. The effect of this is to back up the write pointer to the location that the write pointer was at when it began to write the packet. The next packet to be written will overwrite the packet in error, effectively discarding it. This temporary pointer is similar to the temporary pointer for receive interface 2701, shown in Fig. 30. Setting the write pointer equal to temporary pointer 1 is done by control 4028 placing a signal on conductor 4036. This action is done at the end of each write operation. However, during normal write operations when a packet is not to be discarded, the signal on conductor 4036 does nothing because the other input of AND gate 4010 is disabled. When a discard signal is received, flip-flop 4013 is reset to "0". This turns off AND gate 4012, which disables the writing of both the transmit and switch test buffers, due to the disabling of AND gate 4016. Additionally, when flip-flop 4013 is reset to "0", AND gate 4010 is enabled, which sets the write pointer equal to temporary pointer 1, and thus discards the packet.

Output circuit 1405 is shown in greater detail in Fig. 41. Output circuit 1405 reads data packets, memory read and write packets, and switch test packets from memory 1401, and transmits the packets to the switch network via switch interface 1418. Output circuit 1405 comprises parallel to serial converter 4101 and packet reformatter 4102. Parallel to serial converter 4101 uses conductors 2732 through 2738 to read data from memory 1401, via address control 1404. Data is read in a parallel manner, and appears on cable 2731.

Depending on the packet type, parallel to serial converter 4101 places signals on conductors 2732, 2733, 2735, or 2736 to read receive buffer 1501 or switch test buffer 1504, and to load the temporary pointer. The operation for data memory read or write, and switch test packets are described in the following paragraphs. As parallel to serial converter 4101 is reading memory 1401, it is converting the data to serial, and
 5 transmitting the serial data to packet reformatter 4102. Packet reformatter 4102 receives the packet on conductor 4115, checks the CRC field of the packet, and calculates a new CRC field for the outgoing packet to the switch network. Depending on the packet type, output circuit 1405 also updates several packet fields, such as the source trunk controller, destination trunk controller, length, and control fields. After the packet has been reformatted, it is transmitted to the switch network, via switch interface 1418 on conductor 4117.
 10 Switch interface 1418 indicates that it is ready to receive a packet by placing a signal on conductor 4114. If an error is found in the incoming packet, or during the packet transformation, it is indicated by a signal on one of the conductors 4119 through 4121, which is transmitted to switch interface 1418.

Parallel to serial converter 4101 contains control leads that allow it to access portions of memory 1401 via address control 1404. Access to receive buffer 1501 is provided via conductor 2732. Access to switch
 15 test buffer 1504 is provided via conductor 2733. These access leads provide control only; the information contained in memory is transferred to output circuit 1405 via cable 2731. In order to gain access to memory 1401, a signal must be present on conductor 2760. This signal is provided by timer 2714 contained in address control 1404. Output circuit 1405 also contains control leads for the temporary pointer, provided via conductors 2734 through 2737. The temporary pointer is used to perform memory read operations, as
 20 specified by memory read and memory write packets.

Packet reformatter 4102 receives information from parallel to serial converter 4101 via conductor 4115. It uses the information to assemble the packet that is transmitted to the switch network. This circuit also checks the CRC field of the incoming packet and provides an error indication if an error is found.

The packet transformations provided by output circuit 1405 are shown in Fig. 42, Fig. 43, and Fig. 44.
 25 The packet configuration going into parallel to serial converter 4101 is the packet as it goes into output circuit 1405. The packet configuration going into packet reformatter 4102 is not an actual packet; rather, it is used to illustrate the intermediate step in the actual packet transformation. The packet configuration coming out of packet reformatter 4102 is the actual packet as it leaves output circuit 1405.

Fig. 42 shows the packet transformation that occurs when a data packet (control field of "0") is read
 30 from receive buffer 1501. Fig. 42 is used to illustrate what takes place in the packet when output circuit 1405 reads a data packet. Packet 4201 is the packet as it exists in receive buffer 1501. After parallel to serial converter 4101 receives from address control 1404 a grant signal on conductor 2760, and a data present signal on conductor 2738, it is ready to read receive buffer 1501. This is done by parallel to serial converter 4101 sending a read receive buffer signal to address control 1404 via conductor 2732. This signal causes
 35 address control 1404 to read receive buffer 1501 in memory 1401 and to send the data to parallel to serial converter 4101 on cable 2731. This data appears in parallel and is transformed into a serial bit stream. When the logical address of the packet is read, it is loaded into the temporary pointer, via signals on conductors 2735 through 2737. This address is used to access the proper entry in logical translation table 1505, which is inserted into the packet passed from parallel to serial converter 4101 to packet reformatter
 40 4102. The format of this intermediate packet is shown as 4202 in Fig. 42.

After parallel to serial converter 4101 has read receive buffer 1501 and has read the new logical address, it forwards the information to packet reformatter 4102. Packet reformatter 4102 performs two main functions: it changes the order of certain fields of the incoming information so as to place the source and destination trunk controller numbers in their proper fields, and it places the logical channel translation
 45 table information into the logical address field. Additionally, packet reformatter 4102 checks the CRC field of the incoming information, and calculates a new length and CRC field. This action results in the actual packet 4203.

Fig. 43 shows the packet transformation that occurs during a memory read (control field of "3") or a
 50 memory write (control field of "4") operation. The operations are similar to those for reading a data packet (Fig. 42), with the following exception. In a memory read or memory write, data is read from a memory location specified in the memory read or memory write packet, and the data is placed into the outgoing memory read or memory write packet. At the same time, the remainder of the packet is read from switch test buffer 1504. Packet 4301 is the packet as it exists in switch test buffer 1504. The address field is the memory location of the data that is to be placed in the packet. The count field is the number of bytes of data
 55 that are to be read. The packet is read out of switch test buffer 1504 under control of a signal on conductor 2733. When the address field 4304 is read from the buffer, its value is also saved in the temporary pointer. This is done via signals on conductors 4209 and 4210 as previously described for Fig. 42. After count field 4305 is read, the temporary pointer is used to read information from memory 1401. This information is then placed in the data field. Packet reformatter 4102 updates the length, and destination and source trunk controller fields, and recalculates a new CRC field. This forms the actual packet 4303.
 60

The packet transformation for a switch test packet (control field of "5" or "6") is shown in Fig. 44. For a switch test packet transformation, it is necessary to update the destination trunk control field. This is done by using the data in either the trunk control 1 or trunk control 2 fields. For a first hop switch test packet (control field of "5"), the trunk control 1 field is used. For a second hop switch test packet (control field of
 65 "6"), the trunk control 2 field is used.

Parallel to serial converter 4101 is shown in greater detail in Fig. 45. This circuit comprises address control interface 4501, and buffer 4502. Incoming packets are sent to both address control interface 4501 and buffer 4502 via cable 2731. Address control interface 4501 is informed of the presence of data in either receive buffer 1501 or switch test buffer 1504 via data present signals on conductors 2738 and 2740. It then
 5 controls the transfer of the packets to buffer 4502, which performs the parallel to serial conversion. Address control interface 4501 also controls the reading of the logical channel translation table entries and the data fields of the memory read and memory write packets using the temporary pointer.

Address control interface 4501 is shown in greater detail in Fig. 46. Address control interface 4501 controls the transfer of packets from receive buffer 1501 or switch test buffer 1504 into buffer 4502. The
 10 transfer of the packets is on cable 2731. Address control 4501 also decodes the control field of the packet being read, in order to properly load the temporary pointer; and it reads the length field of the packet being read, in order to determine when the packet has been entirely read.

Address control 1404 indicates the presence of data in receive buffer 1501 by placing a signal on conductor 2738; it indicates the presence of data in switch test buffer 1504 by placing a signal on conductor
 15 2740. Address control interface 4501 responds to this data present signal by placing a signal on either conductor 2732 or 2733, in order to read either receive buffer 1501 or switch test buffer 1504, as appropriate. Additionally, the data present signal from address control 1404 causes control 4602 to start counter 4604. Counter 4604 counts each byte as it is received from cable 2731. This counting is needed to determine when the control and length fields of the incoming packet are present on cable 2731.

The reading of a memory read or memory write packet (control field of "3" or "4") can be illustrated by
 20 also referring to packet 4301 of Fig. 43. Control 4602 receives the "data present in switch test buffer signal" on conductor 2740 and begins to read switch test buffer 1504, as previously described. When the length field appears on cable 2731, it is stored in counter 4603. Counter 4603 begins to count down; when it reaches zero, the packet has been entirely read. When the control field appears on cable 2731, it is decoded by decoder 4601. Once the control field is decoded, it is stored in flip-flops 4605 and 4606. Address control
 25 interface 4501 continues to read the packet from switch test buffer 1504. When the address field appears on cable 2731, this address is loaded into the temporary pointer by control 4602 placing a signal on conductors 2735 and 2736. When the count field appears on cable 2731, it is loaded into counter 4603. Counter 4603 then counts the number of data bytes that are being read from the memory location specified in the
 30 address field. This data is then placed at the end of the packet to form intermediate packet 4302.

Buffer 4502 is shown in greater detail in Fig. 47. Buffer 4502 performs the actual parallel to serial conversion. The presence of a byte on cable 2731 is indicated by a signal from address control interface
 35 4501 on conductor 4504. The load signal is provided on conductor 4503. This load signal causes the first byte on cable 2731 to be loaded into input register 4701. Control 4703 then loads the byte into shift register 4702. Shift register 4702 then shifts the byte out onto conductor 4215 in a serial manner. This shifting is activated via a signal from control 4703 on conductor 4706. Control 4703 also causes counter 4704 to begin counting. Counter 4704 counts the bit times to indicate when the byte has been completely shifted out of
 40 shift register 4702. During the time that the contents of shift register 4702 are being shifted out serially, the next byte on cable 2731 is loaded into input register 4701, which buffers this byte until the data in shift register 4702 has been completely shifted out. After the data in shift register 4702 has been completely shifted out, control 4703 causes the contents of register 4701 to be passed to shift register 4702, via a signal on conductor 4705. Control 4703 then resets counter 4704, and sends an acknowledge signal back to address control interface 4501 via conductor 4505. Buffer 4502 is receiving a continuous ready indication from switch interface 1418 on conductor 4114. If switch interface 1418 is overloaded and cannot receive
 45 packets, it removes this ready signal. When this occurs, data is not shifted out of shift register 4702 until the ready signal appears again.

Packet reformatter 4102 is shown in greater detail in Fig. 48. Packet reformatter 4102 comprises packet reformat circuits 4801 and 4802, and comparator 4803. The duplicate packet reformatters are necessary for
 50 detecting hardware failures, as previously explained. If an error is found in the reformatting, comparator 4803 detects the error and places a signal on conductor 4121. This fault signal is sent to the central processor via switch interface 1418. If the CRC check of the incoming packet shows that the packet was received in error, a signal is placed on conductor 4119; if the check on the logical channel translation table entry reveals an error, a signal is placed on conductor 4120. Both signals are sent to switch interface 1418.

Packet reformat circuit 4801 is shown in greater detail in Fig. 49. Packet reformat circuit 4801 performs
 55 two basic functions: it checks the CRC field of the incoming packet and reports any errors, and it reformats certain fields, depending on the type of packet received. Errors are reported by check CRC circuit 4905, which checks the CRC field of the incoming packet, and the check field of the logical channel translation table entry. If the incoming packet contains errors, it is reported via a signal on either conductor 4119 or 4120 as previously described. This operation is the same regardless of the type of packet received.

Packet reformat circuit 4801 is described with respect to handling an ordinary packet (control field of
 60 "0"), similar to packet 4202. The incoming packet is received by packet reformat circuit 4801 on conductor 4115, and shifted into register 4901 in a serial manner. The bits are moved through packet reformat circuit 4801 in a continuous stream under control of system clock 161. Timing generator 4904 keeps track of where each bit is in register 4901. This allows control 4903 to access various areas in shift register 4901, via data selector 4902, in order to shift various fields into the appropriate reformatting circuits 4906 through 4908, or
 65

decoder 4909. When the control and PID fields are at the correct locations in shift register 4901, control 4903 causes these fields to be shifted into decoder 4909. Decoder 4909 decodes these fields and sends the decoded values to control 4903. After 256 bits have been shifted into register 4901, the length field, which is now stored in register 4901, is selected by data selector 4902 and sent to data selector 4910 via conductor 4912. In this particular case, the length field does not change and thus is passed directly to the output. The DTC field, which is located in the logical channel translation table entry field, is then shifted out of register 4901 via data selector 4902, and sent to data selector 4910. The next field to consider is the STC field. The value of this field is hard-wired into format STC circuit 4906. Control 4903 causes format STC circuit 4906 to shift this value into data selector 4910. The control, arrival time, and packet identifier fields are next selected by data selector 4902 and shifted to data selector 4910, under control of control 4903. The new logical address must be removed from the logical channel translation table entry field, contained in register 4901. To do this, control 4903 causes data selector 4902 to select this field, and send the new logical address to data selector 4910. As each field is sent to data selector 4910, control 4903 causes data selector 4910 to send these fields (which now constitute the entire packet) to format CRC circuit 4911. Format CRC circuit 4911 is recalculating a new CRC field as the packet is being shifted through. Once the entire packet has been shifted through format CRC circuit 4911, format CRC circuit 4911 calculates a new CRC field, based on the updated fields, and adds the new CRC field to the end of the packet. The reformatted packet is then sent to switch interface 1418 via conductor 4117. Control 4903 generates the required data present signals on conductor 4118.

Transmitter 1403 is shown in greater detail in Fig. 50. Transmitter 1403 reads data from memory 1401, via address control 1404, and converts the data into trunk packets, which are sent to the next trunk controller or to the concentrator in the end office. Transmitter 1403 comprises parallel to serial converter 5001, packet reformatter 5002, and flag and bit stuff circuit 5003. Transmitter 1403 receives data present in transmit buffer, and data present in trunk test buffer signal from address control 1404 via conductors 2756 and 2758. When transmitter 1403 receives a signal on conductor 2766, it reads transmit buffer 1503 in memory 1401 by placing a signal on conductor 2754. This signal causes address control 1404 to read the data from transmit buffer 1503, and forward the data to Transmitter 1403 via cable 2755. Similarly, transmitter 1403 reads data from trunk test buffer 1502 in memory 1401 by placing a signal on conductor 2753. After the data has been read from either transmit buffer 1503 or trunk test buffer 1502, the data is converted from parallel to serial, and passed to packet reformatter 5002 via conductor 5013. Packet reformatter 5002 indicates it is ready to receive data by placing a signal on conductor 5015. Packet reformatter 5002 fills in the time stamp field, and updates the PID field, as required, to reflect any flow control change. The flow control information is received from switch interface 1418 via cable 5012. Additionally, packet reformatter 5002 checks the CRC field of the incoming packet for errors, and recalculates a new CRC field, based on the added field information. Packet reformatter 5002 passes the packet to flag and bit stuff circuit 5003 via conductor 5016. Flag and bit stuff circuit 5003 adds the flag pattern to the beginning and end of the outgoing packet, and stuffs a zero after any sequence of five ones. Flag and bit stuff circuit 5003 then transmits the trunk packet to the trunk via conductor 5019 at a 1.544 Mb/s rate.

Packet reformatter 5002 is shown in greater detail in Fig. 51. Packet reformatter 5002 comprises CRC circuits 5101 and 5104, packet reformat circuits 5102 and 5105, and comparator 5103. This circuit contains duplicate CRC and packet reformatters, which are required to detect hardware failures, as has been previously explained. If an error is detected, it is indicated by a signal on conductor 5021.

Packet reformat circuit 5102 is shown in greater detail in Fig. 52. This circuit updates the time stamp field, PID field, and CRC field. Format time stamp circuit 5201 updates the time stamp field of the packet by calculating the difference between arrival time, already contained in the arrival time field, and the present time, which is maintained by format time stamp circuit 5201. This calculation was described in the detailed description for receiver 1402. Format time stamp circuit 5201 also removes the header information from the packet so as to convert it from a switch packet to a trunk packet. PID circuit 5202 updates the PID field, based on the current flow control which is maintained in switch interface 1418. Flow control information is passed to PID circuit 5202 via cable 5012. CRC circuit 5203 recalculates a new CRC field using the updated time stamp and PID fields, in addition to the other packet fields. Once packet reformatter 5202 has updated all necessary fields, it passes the packet to flag and bit stuff circuit 5003.

Format time stamp circuit 5201 is shown in greater detail in Fig. 53. Format time stamp circuit 5201 reads the arrival time of the incoming packet from the arrival time field, computes the difference between the arrival time and the current time, and adds this difference to the time stamp field. Format time stamp circuit 5201 also removes fields from the incoming packet, in order to transform it from a switch packet into a trunk packet. The present time is maintained by counter 5302, which is controlled via external timing signals on conductors 5010 and 5011. When the first data present is received on conductor 5107 it is sent to control 5303, which causes the contents of counter 5302 to be written into shift register 5301. The signal on conductor 5107 also causes control 5303 to start counter 5312. Counter 5312 counts the data present signals as they arrive on conductor 5107, in order to determine when the various fields are present on conductor 5106. When the arrival time field of the packet is present on conductor 5106, control 5303 causes the arrival time to be shifted to serial adder 5304 and, at the same time, control 5303 causes the current time, previously stored in shift register 5301, to be shifted to serial adder 5304. Serial adder 5304 adds the

current time to the arrival time field and places the sum in shift register 5305. Since the arrival time field is encoded as a negative number, this calculation yields the difference between the current time and the arrival time. When counter 5312 indicates that the time stamp field of the incoming packet is present on conductor 5106, control 5303 causes the time stamp field to be shifted to serial adder 5306, and, at the same time, control 5303 causes the contents of shift register 5305 to be sent to serial adder 5306. Serial adder 5306 then adds these numbers, and places the sum into the time stamp field of the incoming packet, thus updating the time stamp field. The fields that must be stripped off of the packet to transform the packet from a switch packet to a trunk packet are stripped off as follows. Control 5303 removes the signal on AND gate 5310 when the fields that are to be stripped off are present on conductor 5106. This removes the data present signal from conductor 5205 during the bit times that the fields that are to be removed are present on conductor 5106. The removal of this data present signal causes the following circuits to ignore the data that is present on conductor 5204 during the bit times that the data present signal is removed.

Fig. 54 shows the clock rates from system clock 161. The psi clock rate is the rate that incoming data enters receiver 1402. The phi rate is the rate that the data leaves receiver 1402, passes through the various circuits in trunk controller 131, and is sent to the switching network. The theta rate is the rate that data is transferred in and out of memory 1401 by address control 1404.

Claims

1. A packet switch for switching packets of digital signals between a plurality of input terminals (133) and a plurality of output terminals (132), and said switch comprising:
 - a plurality of input control means (1000) each of which is connected to an individual one of said input terminals,
 - a plurality of output control means (1004) each of which is connected to an individual one of said output terminals,
 - means (1014) individually connecting each of said input control means (1000) to each of said output control means (1004), characterized in that
 - each of said packets comprises an address field of said digital bit signals defining a packet communication path from an individual one of said input control means over said connecting means and an individual one of said output control means to said individual one of said output terminals connected thereto,
 - the input control means (1000) comprises:
 - means (1100) for storing address and other digital bit signals of a packet received from said individual one of said input terminals (133) and
 - means responsive to a receipt of said address signals for sending a packet communication request signal to the address designated output control means;
 - means (1104) for controlling said storing means to commence a transmission therefrom of address and other digital bit signals of said received packet to the one of said output terminals identified by the stored address signals of said packet immediately upon receipt of a packet communication availability signal indicating an idle condition of said defined one of said output terminals.
 2. The packet switch of claim 1 characterized in that said controlling means comprises:
 - means responsive to a predetermined number of a plurality of address bits in said received packet for routing said stored address and other digital bit signals to said defined one of said output terminals, and
 - means (1106) for repositioning said predetermined number of address bits in said plurality of address bits in the routing of said packet to said defined one of said output terminals.
 3. The packet switch of claim 2 characterized in that
 - said predetermined number of address bits located in a most significant address bit position in said packet, and said repositioning means (1106) relocates said predetermined number of address bits to a least significant address bit position in said packet.
 4. The packet switch of claim 3 characterized in that said rearranging means of said repositioning means comprises:
 - first (1200) and second (1203) shift register circuits each having an input and an output means said input means of said first shift register circuit connected to said storing means for receiving said stored digital bit signals therefrom, and said input means of said second shift register circuit connected to said output means of said first shift register circuit for receiving said stored digital bit signals therefrom,
 - selecting means (1202) operable for selecting said digital bit signals of said address field from said output means of said first and second shift register circuits, and
 - control circuit means (1209) responsive to said digital bit signals of said address field for operating said selecting means sequentially to select said digital bit signals of said address field from said first and second shift register circuits to effect a rotation of said predetermined number of said digital bit signals of said address field to a least significant bit position of said address field.
 5. A packet switch according to claim 4 characterized in that
 - said controlling means is responsive to address field signals stored in said storing means for sending said packet communication request signal over said connecting means to said identified one of said output control means.

6. A packet switch according to claim 5 characterized in that
 said buffer means comprises a plural stage buffer shift register for storing said packet digital signals
 and having a first stage, intermediate stages and a last stage, and being operative in response to a
 sequential receipt of packet digital signals for shifting the received digital signals from said first stage
 5 intermediate stages toward said last stage, each of said register stages comprising stage output means for
 deriving the shifted digital signals thereat,

selector means operable for selecting a one of said stage output means storing a start-of-packet digital
 signal of said received packet and to commence a communication of said received packet from said
 selector means toward said defined one of said output control means, and

10 said controller means being further responsive for operating said selector means upon receipt of said
 packet communication availability signal.

7. A packet switch according to claim 6 characterized in that

said storing means further comprises a plural stage input shift register having an input for sequentially
 receiving packet digital signals to effect a storage of said digital signals in said input shift registers, a serial
 15 output for sequentially supplying the stored packet digital signals to said buffer shift register, and address
 bit outputs for deriving stored address bit signals of said received digital signals,

further comprising an address register operable for registering said stored address bit signals
 identifying that said defined one of said output control means is to receive said stored packet digital
 signals, and

20 said controlling means being further responsive to a start-of-packet signal stored in said input shift
 register and to address bit signals stored in said address register for sending said packet communication
 request signal over said connecting means to said defined one of said output control means.

8. A packet switch according to claim 7 characterized in that

said input shift register further comprises output means furnishing signals signifying the length of the
 25 packet stored therein,

further comprising a packet length register means responsive to said packet length signals for
 activating said controlling means to control said selector means for terminating said communication of
 said packet from said selector means toward said defined one of said output control means.

9. A packet switch according to claim 8 characterized in that the input shift register further comprising:

30 device means operable for supplying said packet communication available signal to said individual
 one of said input terminals connected to said each input control means, and wherein

said controlling means is further activated by said packet length register means to control the
 operation of said device means upon a terminating of said communication of said packet from said selector
 means toward said defined one of said output control means.

35 **Patentansprüche**

1. Paketvermittlungseinheit zur Vermittlung von Paketen digitaler Signale zwischen einer Vielzahl von
 Eingabeanschlüssen (133) und einer Vielzahl von Ausgabeanschlüssen (132), wobei die
 40 Vermittlungseinheit umfaßt:

eine Vielzahl von Eingabesteuereinrichtungen (1000), von denen jede mit einer bestimmten
 Eingabeanschlüsse verbunden ist,

eine Vielzahl von Ausgabesteuereinrichtungen (1004), von denen jede mit einer bestimmten
 Ausgabeanschlüsse verbunden ist, und

45 eine Einrichtung (1014), die einzeln jede Eingabesteuereinrichtung (1000) mit jeder
 Ausgabesteuereinrichtung (1004) verbindet, dadurch gekennzeichnet, daß

jedes der Pakete ein Adressenfeld aus den digitalen Bitsignalen zur Festlegung eines
 Paketnachrichtenweges von einer bestimmten Eingabesteuereinrichtung über die Verbindungseinrichtung
 und eine bestimmte Ausgabesteuereinrichtung zu der damit verbundenen bestimmten
 50 Ausgabeanschlüsse enthält,

wobei die Eingabesteuereinrichtung (1000) enthält:

eine Einrichtung (1100) zur Speicherung von Adressen- und weiteren digitalen Bitsignalen eines von
 der Eingabeanschlüsse (133) empfangenen Pakets und eine Einrichtung, die unter Ansprechen auf den
 Empfang der Adressensignale ein Paketübertragungsanforderungssignal zu der durch die Adresse
 55 bezeichneten Ausgabesteuereinrichtung sendet;

eine Einrichtung (1104), die die Speichereinrichtung veranlaßt, eine Übermittlung von Adressen- und
 weiteren digitalen Bitsignalen des empfangenen Pakets aus der Speichereinrichtung zu den durch die
 gespeicherten Adressensignale identifizierten Ausgabeanschlüssen zu beginnen, und zwar unmittelbar
 nach dem Empfang eines Paketübertragungsverfügbarkeitssignals, das einen Freizustand der definierten
 60 Ausgabeanschlüsse angibt.

2. Paketvermittlungseinheit nach Anspruch 1, dadurch gekennzeichnet, daß

die Steuereinrichtung eine Einrichtung enthält, die unter Ansprechen auf eine vorbestimmte Anzahl
 aus einer Vielzahl von Adressenbits des empfangenen Pakets, die gespeicherten Adressen- und weiteren
 digitalen Bitsignale zu der definierten Ausgabeanschlüsse weiterleitet, und

65 eine Einrichtung (1106) zur Neupositionierung der vorbestimmten Anzahl von Adressenbits aus der

0 112 831

Vielzahl von Adressenbits während der Weiterleitung des Pakets zu den definierten Ausgabeanschlußstellen.

3. Paketvermittlungseinheit nach Anspruch 2, dadurch gekennzeichnet, daß sich die vorbestimmte Anzahl von Adressenbits in einer höchstwertigen Adressenbitstelle in dem
5 Paket befindet und daß die Neupositionierungseinrichtung (1106) die vorbestimmte Anzahl von Adressenbits in eine niedrigstwertige Adressenbitstelle des Pakets umordnet.

4. Paketvermittlungseinheit nach Anspruch 3, dadurch gekennzeichnet, daß die Umordnungseinrichtung der Neupositionierungseinrichtung enthält:
eine erste (1200) und eine zweite (1203) Schieberegisterschaltung mit jeweils einer Eingabe- und einer
10 Ausgabeeinrichtung, wobei die Eingabeeinrichtung der ersten Schieberegisterschaltung mit der Speichereinrichtung verbunden ist, um von dort die gespeicherten digitalen Bitsignale zu empfangen, und die Eingabeeinrichtung der zweiten Schieberegisterschaltung mit der Ausgabeeinrichtung der ersten Schieberegisterschaltung verbunden ist, um von dort die gespeicherten digitalen Bitsignale zu empfangen,
eine Auswahleinrichtung (1202), die die digitalen Bitsignale des Adressenfeldes von der
15 Ausgabeeinrichtung der ersten und zweiten Schieberegisterschaltung auswählen kann, und eine Steuerschaltungseinrichtung (1209), die unter Ansprechen auf die digitalen Bitsignale des Adressenfeldes die Auswahleinrichtung veranlaßt, die digitalen Bitsignale des Adressenfeldes von der ersten und zweiten Schieberegisterschaltung sequentiell auszuwählen, um eine Rotation der vorbestimmten Anzahl der digitalen Bitsignale des Adressenfeldes zu einer niedrigstwertigen Bitstelle des
20 Adressenfeldes zu bewirken.

5. Paketvermittlungseinheit nach Anspruch 4, dadurch gekennzeichnet, daß die Steuereinrichtung unter Ansprechen auf in der Speichereinrichtung gespeicherte Adressenfeldsignale das Paketübermittlungsanforderungssignal über die Verbindungseinrichtung zu der identifizierten Ausgabesteuereinrichtung überträgt.

6. Paketvermittlungseinheit nach Anspruch 5, dadurch gekennzeichnet, daß die Speichereinrichtung ein vielstufiges Pufferschieberegister zur Speicherung der digitalen Paketsignale mit einer ersten Stufe, Zwischenstufen und einer letzten Stufe besitzt und unter Ansprechen auf den sequentiellen Empfang von digitalen Paketsignalen die empfangenen digitalen Signale von der ersten Stufe über die Zwischenstufen zur letzten Stufe verschiebt, wobei jede der Registerstufen eine
25 Stufenausgangseinrichtung enthält, die die verschobenen digitalen Signale liefert, und eine Auswahleinrichtung, die eine der Stufenausgabeeinrichtungen, welche ein digitales Paketanfangssignal des empfangenen Pakets speichert, auswählen kann und eine Übermittlung des empfangenen Pakets von der Auswahleinrichtung zu der definierten Ausgabesteuereinrichtung einleitet, und
30 daß die Steuereinrichtung die Auswahleinrichtung bei Empfang des Paketübertragungsverfügbarkeits-
signals betätigt.

7. Paketvermittlungseinheit nach Anspruch 6, dadurch gekennzeichnet, daß die Speichereinrichtung ein vielstufiges Eingangsschieberegister ausweist, das einen Eingang zum sequentiellen Empfang von digitalen Paketsignalen zwecks Speicherung der digitalen Signale in dem Eingangsschieberegister, einen
40 seriellen Ausgang zur sequentiellen Lieferung der gespeicherten digitalen Paketsignale an das Pufferschieberegister und Adressenbitausgänge zur Ableitung von gespeicherten Adressenbitsignalen aus den empfangenen digitalen Signalen enthält, und ferner ein Adressenregister zur Aufnahme der gespeicherten Adressenbitsignale, die angeben, daß die ausgewählte Ausgabesteuereinrichtung die gespeicherten digitalen Paketsignale empfangen soll,
45 aufweist, daß die Steuereinrichtung unter Ansprechen auf ein in dem Eingangsschieberegister gespeichertes Paketanfangssignal und in dem Adressenregister gespeicherte Adressenbitsignale das Paketübermittlungsanforderungssignal über die Verbindungseinrichtung zu der definierten Ausgabesteuereinrichtung überträgt.

8. Paketvermittlungseinheit nach Anspruch 7, dadurch gekennzeichnet, daß
50 das Eingangsschieberegister eine Ausgangseinrichtung aufweist, die die Länge des dort gespeicherten Pakets angegebene Signale liefert, und ein Paketlängenregister, das unter Ansprechen auf die Paketlängensignale die Steuereinrichtung zur Steuerung der Auswahleinrichtung aktiviert, um die Übermittlung des Pakets von der Auswahleinrichtung zu der definierten Ausgabesteuereinrichtung zu beenden.

9. Paketvermittlungseinheit nach Anspruch 8, dadurch gekennzeichnet, daß
55 das Eingangsschieberegister eine Geräteeinheit enthält, die das Paketübertragungsverfügbarkeits-
signal an diejenige bestimmte Eingabeanschlußstelle liefert, welche mit der Eingabesteuereinrichtung verbunden ist, und daß die Steuereinrichtung durch das Paketlängenregister zur Steuerung der Geräteeinheit bei Beendigung der Übermittlung des Pakets von der Auswahleinrichtung zu der
60 ausgewählten Ausgangssteuereinrichtung aktiviert wird.

Revendications

1. Un commutateur de paquets destiné à commuter des paquets de signaux numériques entre un
65 ensemble de bornes d'entrée (133) et un ensemble de bornes de sortie (132), ce commutateur comprenant:

0 112 831

un ensemble de moyens de commande d'entrée (1000) chacun d'eux étant connecté à l'une individuelle des bornes d'entrée,

un ensemble de moyens de commande de sortie (1004), chacun d'eux étant connecté à l'une individuelle des bornes de sortie,

5 des moyens (1014) connectant individuellement chacun des moyens de commande d'entrée (1000) à chacun des moyens de commande de sortie (1004), caractérisé en ce que

chacun des paquets comprend une zone d'adresse de signaux de bits numériques définissant un chemin de transmission de paquet à partir de l'un individuel des moyens de commande d'entrée, par l'intermédiaire des moyens de connexion et de l'un individuel des moyens de commande de sortie, vers la

10 borne individuelle qui lui est connectée, parmi les bornes de sortie,

les moyens de commande d'entrée (1000) comprennent:

des moyens (1100) destinés à enregistrer des signaux d'adresse et d'autres signaux de bits numériques d'un paquet reçu à partir de la borne individuelle parmi les bornes d'entrée (133), et

des moyens qui réagissent à la réception des signaux d'adresse en émettant un signal de demande de

15 transmission de paquet vers les moyens de commande de sortie désignés par l'adresse;

des moyens (1104) destinés à commander les moyens d'enregistrement pour commencer une émission à partir de ceux-ci de signaux d'adresse et d'autres signaux de bits numériques du paquet reçu, vers celle des bornes de sortie qui est identifiée par les signaux d'adresse enregistrés du paquet, dès la réception d'un signal de possibilité de transmission de paquet qui indique un état inactif de la borne définie

20 parmi les bornes de sortie.

2. Le commutateur de paquets de la revendication 1 caractérisé en ce que les moyens de commande comprennent:

des moyens qui réagissent à un nombre prédéterminé de bits parmi un ensemble de bits d'adresse dans le paquet reçu, en dirigeant les signaux d'adresse et d'autres signaux de bits numériques enregistrés

25 vers la borne définie parmi les bornes de sortie, et

des moyens (1106) destinés à repositionner le nombre prédéterminé de bits d'adresse parmi l'ensemble de bits d'adresse au cours de l'acheminement du paquet vers la borne définie parmi les bornes de sortie.

3. Le commutateur de paquets de la revendication 2 caractérisé en ce que

30 le nombre prédéterminé de bits d'adresse se trouvent dans une position de bits d'adresse de plus fort poids dans le paquet, et les moyens de repositionnement (1106) replacent le nombre prédéterminé de bits d'adresse dans une position de bits d'adresse de moindre poids dans le paquet.

4. Le commutateur de paquets de la revendication 3 caractérisé en ce que les moyens de réarrangement des moyens de repositionnement comprennent:

35 des premier (1200) et second (1203) circuits de registre à décalage, ayant chacun des moyens d'entrée et des moyens de sortie, les moyens d'entrée du premier circuit de registre à décalage étant connectés aux moyens d'enregistrement pour recevoir à partir d'eux les signaux de bits numériques enregistrés, et les moyens d'entrée du second circuit de registre à décalage étant connectés aux moyens de sortie du premier circuit de registre à décalage pour recevoir à partir d'eux les signaux de bits numériques enregistrés,

40 des moyens de sélection (1202) qu'on peut actionner pour sélectionner les signaux de bits numériques de la zone d'adresse provenant des moyens de sortie des premier et second circuits de registre à décalage, et

un circuit de commande (1209) qui réagit aux signaux de bits numériques de la zone d'adresse en actionnant séquentiellement les moyens de sélection, pour sélectionner les signaux de bits numériques de

45 la zone d'adresse provenant des premier et second circuits de registre à décalage, pour soumettre à une rotation le nombre prédéterminé de signaux de bits numériques de la zone d'adresse, de façon à les amener dans une position de bits de moindre poids de la zone d'adresse.

5. Un commutateur de paquets selon la revendication 4 caractérisé en ce que

50 les moyens de commande réagissent à des signaux de zone d'adresse enregistrés dans les moyens d'enregistrement, en émettant le signal de demande de transmission de paquet, par les moyens de connexion, vers le moyen identifié parmi les moyens de commande de sortie.

6. Un commutateur de paquets selon la revendication 5 caractérisé en ce que

les moyens d'enregistrement en tampon comprennent un registre à décalage tampon à plusieurs étages destiné à enregistrer les signaux numériques de paquets et comportant un premier étage, des

55 étages intermédiaires et un dernier étage, ce registre réagissant à la réception séquentielle de signaux numériques de paquets en décalant les signaux numériques reçus à partir du premier étage vers le dernier étage, en passant par les étages intermédiaires, chacun des étages du registre comprenant des moyens de sortie d'étage destinés à fournir les signaux numériques décalés qui se trouvent dans l'étage considéré,

60 des moyens sélecteurs qu'on peut faire fonctionner de façon à sélectionner l'un des moyens de sortie d'étage enregistrant un signal numérique de début de paquet appartenant au paquet reçu, et à commencer une transmission du paquet reçu, à partir des moyens sélecteurs vers le moyen défini parmi les moyens de commande de sortie, et

les moyens de commande actionnent en outre les moyens sélecteurs à la réception du signal de possibilité de transmission de paquet.

65 7. Un commutateur de paquets selon la revendication 6 caractérisé en ce que

0 112 831

les moyens d'enregistrement comprennent en outre un registre à décalage d'entrée à plusieurs étages ayant une entrée destinée à recevoir séquentiellement des signaux numériques de paquets, pour enregistrer ces signaux numériques dans le registre à décalage d'entrée, une sortie série destinée à appliquer séquentiellement les signaux numériques de paquets enregistrés au registre à décalage tampon, et des sorties de bits d'adresse destinées à fournir des signaux de bits d'adresse enregistrés faisant partie des signaux numériques reçus,

il existe en outre un registre d'adresse qu'on peut actionner pour mémoriser les signaux de bits d'adresse enregistrés qui indiquent que le moyen défini parmi les moyens de commande de sortie doit recevoir les signaux numériques de paquets enregistrés, et

les moyens de commande réagissent en outre au signal de début de paquet qui est enregistré dans le registre à décalage d'entrée et aux signaux de bits d'adresse qui sont enregistrés dans le registre d'adresse, en émettant le signal de demande de transmission de paquet, par les moyens de connexion, vers le moyen défini parmi les moyens de commande de sortie.

8. Un commutateur de paquets selon la revendication 7 caractérisé en ce que

le registre à décalage d'entrée comprend en outre des moyens de sortie qui fournissent des signaux indiquant la longueur du paquet enregistré à l'intérieur,

et il existe en outre un registre de longueur de paquet qui réagit aux signaux de longueur de paquet en activant les moyens de commande pour qu'ils commandent les moyens sélecteurs de façon à mettre fin à la transmission du paquet des moyens sélecteurs vers le moyen défini parmi les moyens de commande de sortie.

9. Un commutateur de paquets selon la revendication 8 caractérisé en ce que le registre à décalage d'entrée comprend en outre:

un dispositif qu'on peut actionner de façon à appliquer le signal de possibilité de transmission de paquet à la borne individuelle précitée parmi les bornes d'entrée connectées à chacun des moyens de commande d'entrée, et dans lequel

les moyens de commande sont en outre activés par le registre de longueur de paquet de façon à commander le fonctionnement du dispositif précité au moment de la terminaison de la transmission du paquet des moyens sélecteurs vers le moyen défini parmi les moyens de commande de sortie.

30

35

40

45

50

55

60

65

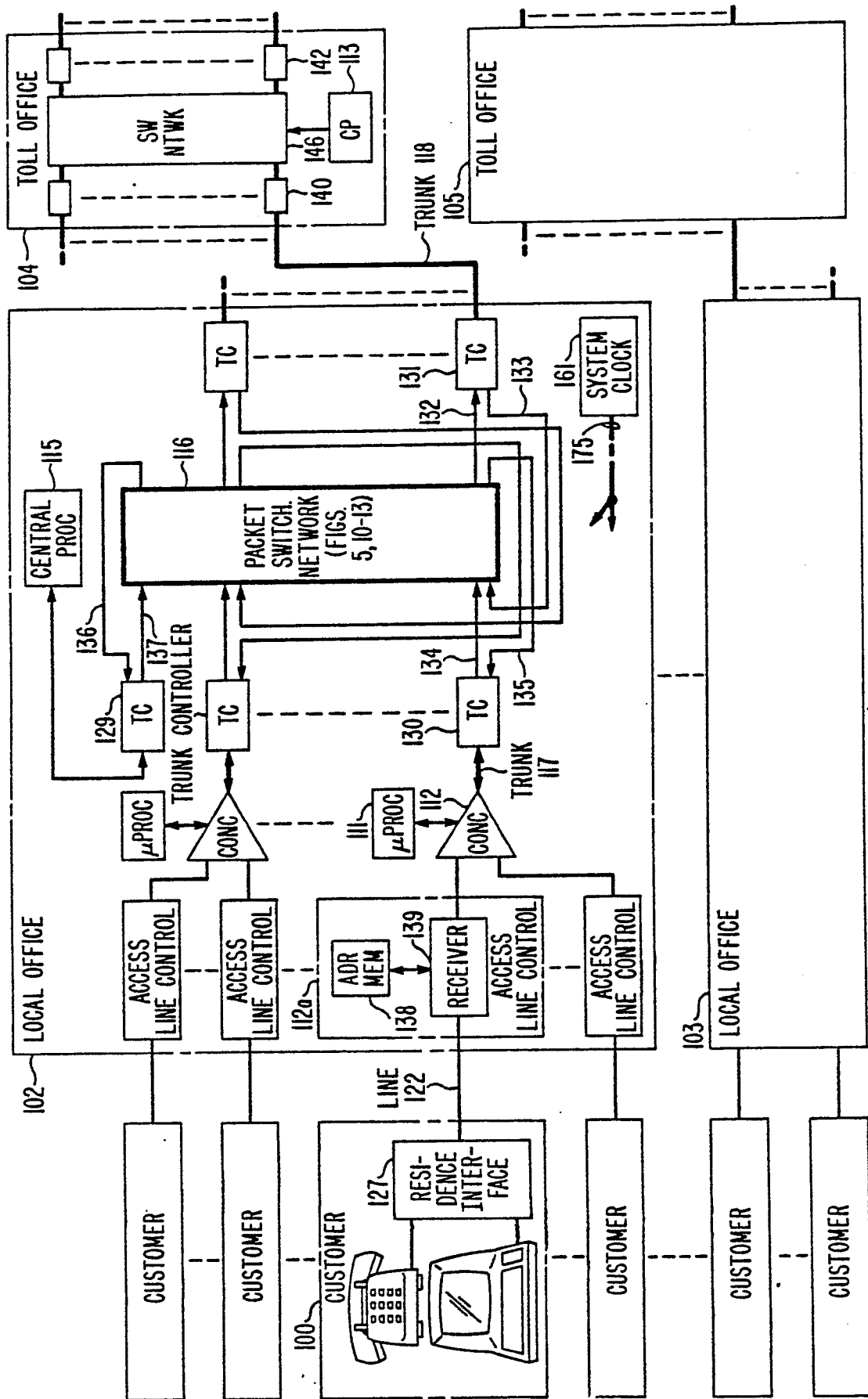

FIG. 1

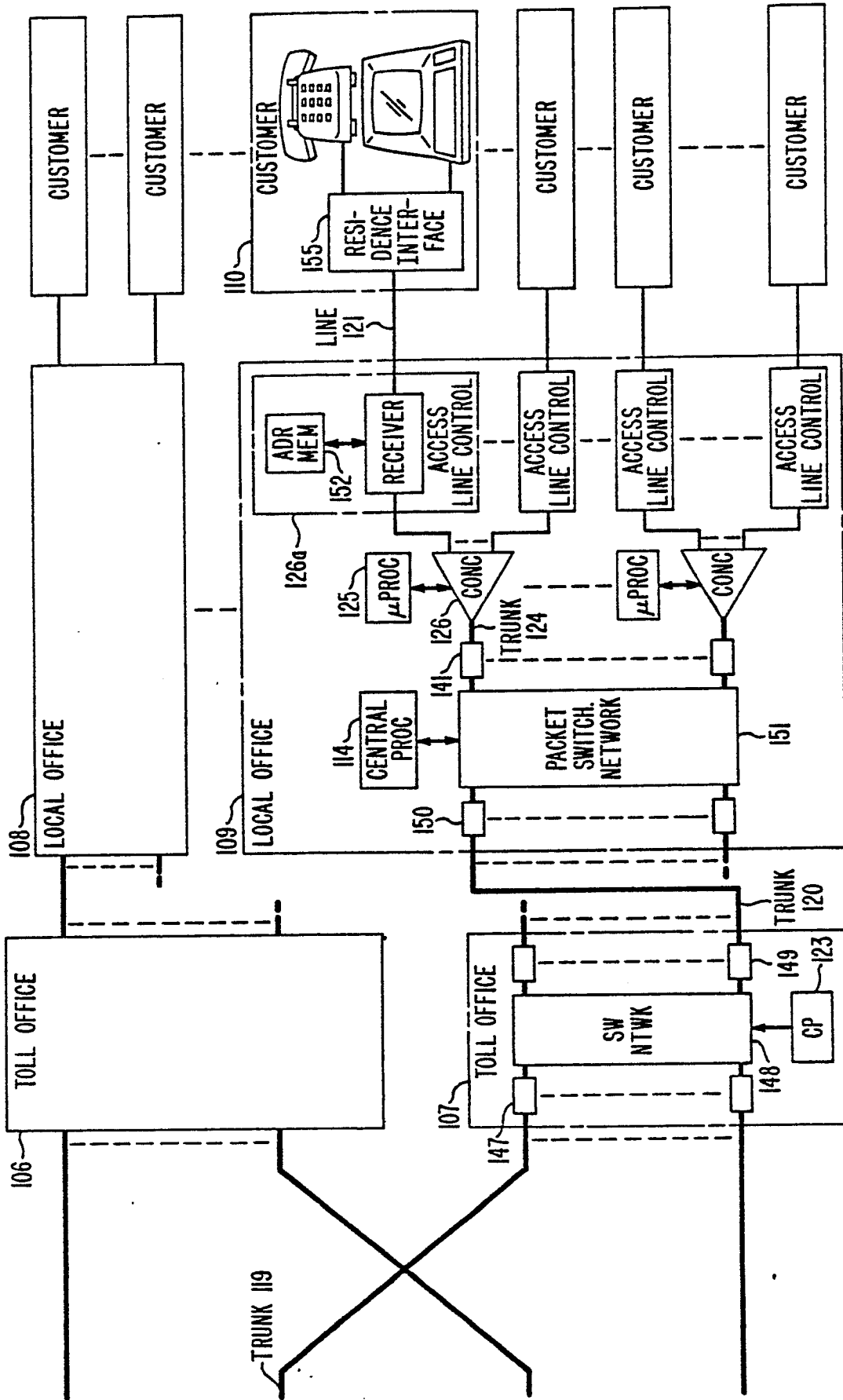

FIG. 2

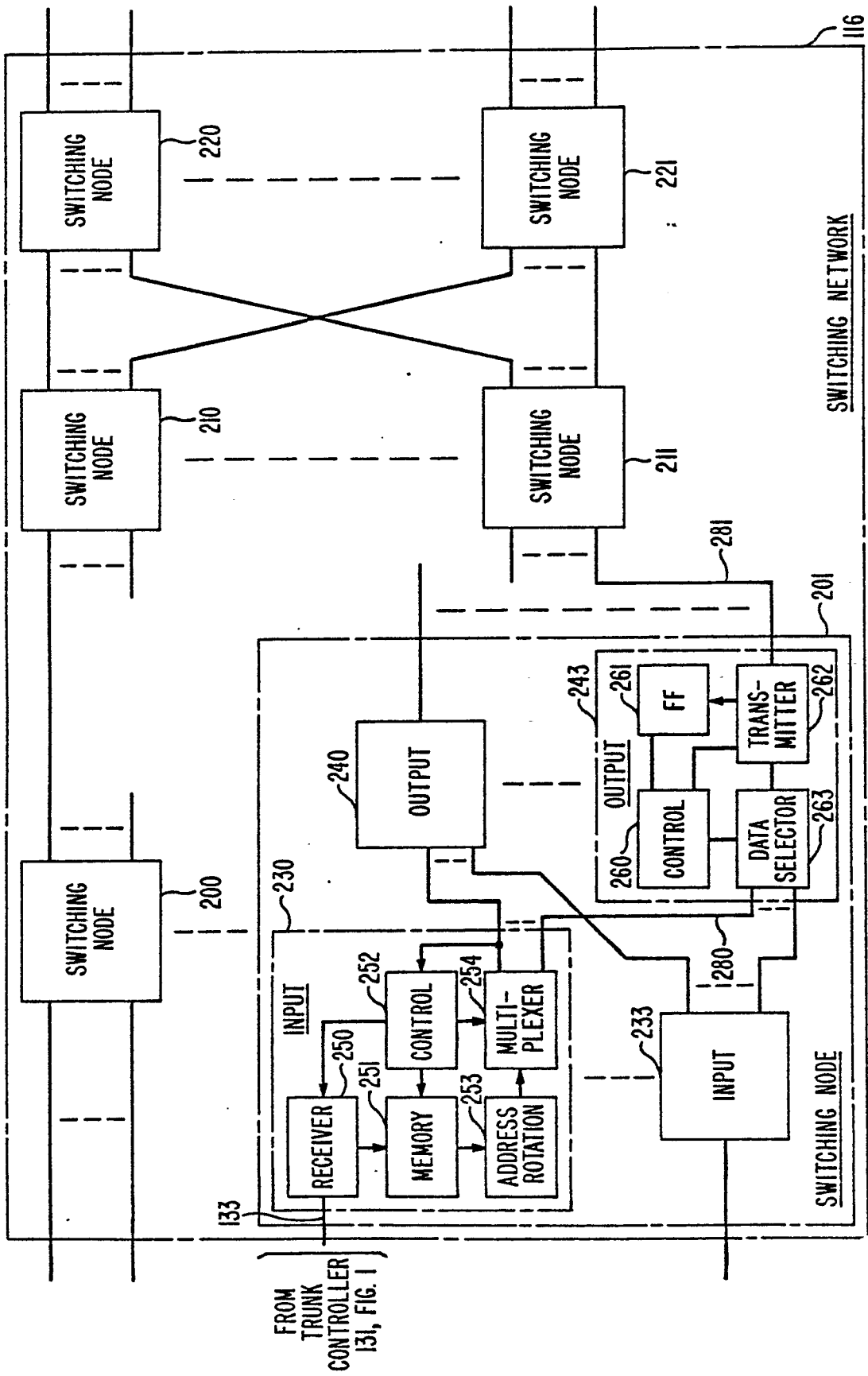
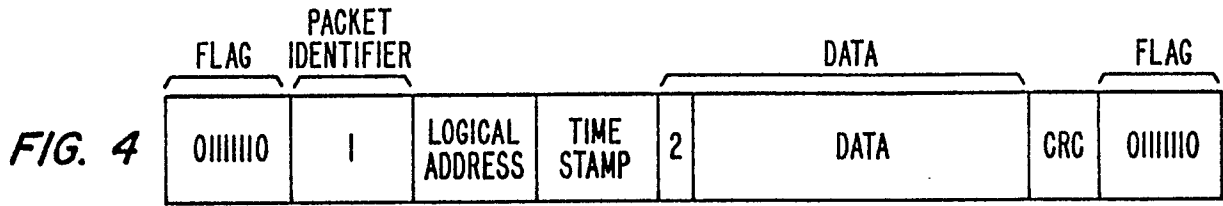
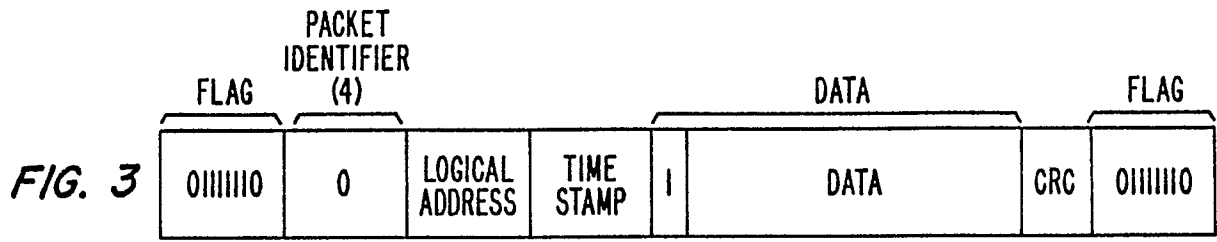
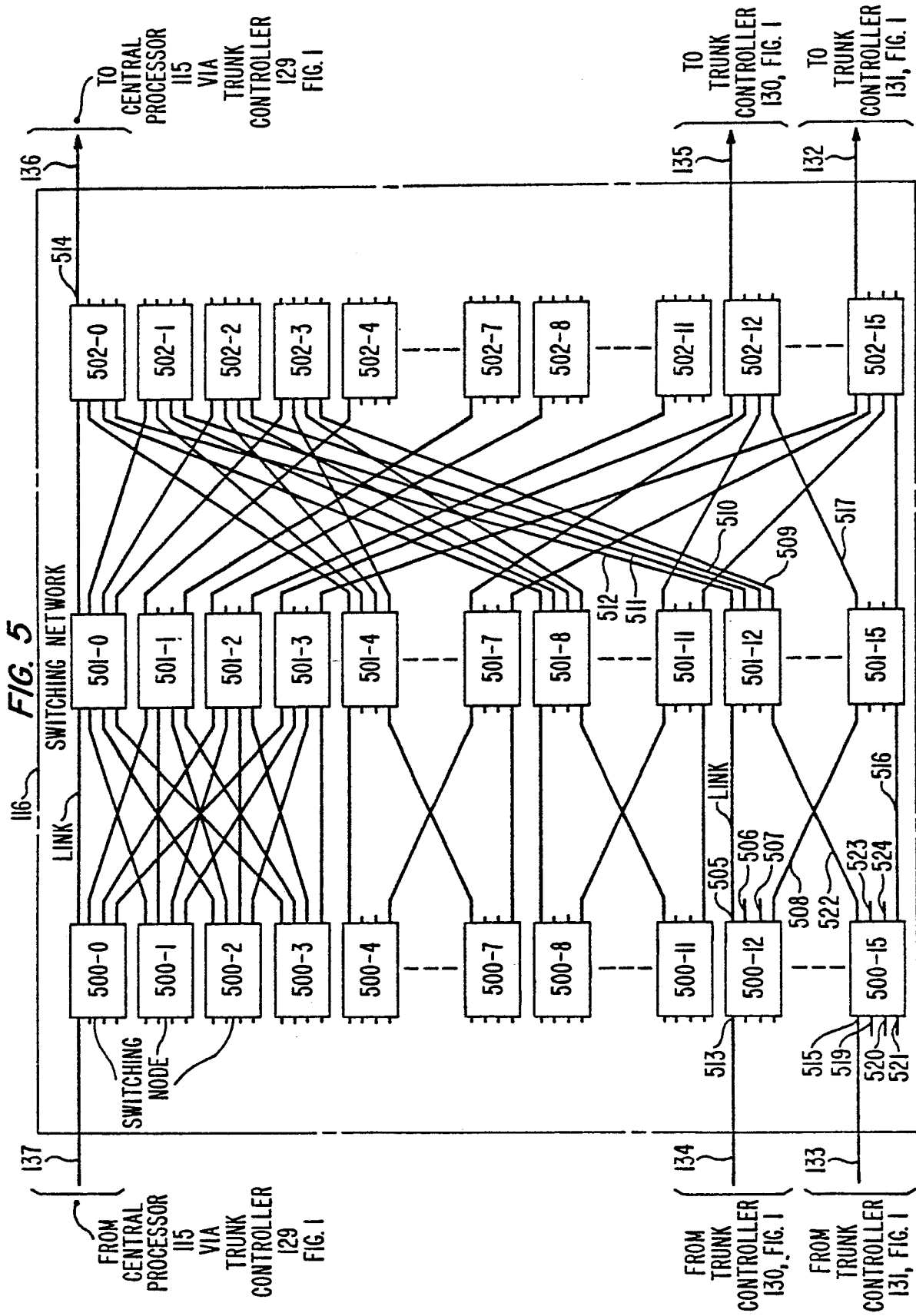

FIG. 2A





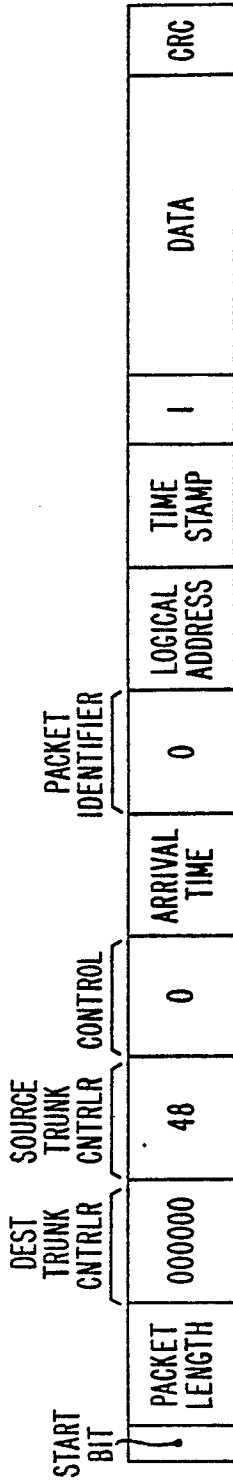

FIG. 6

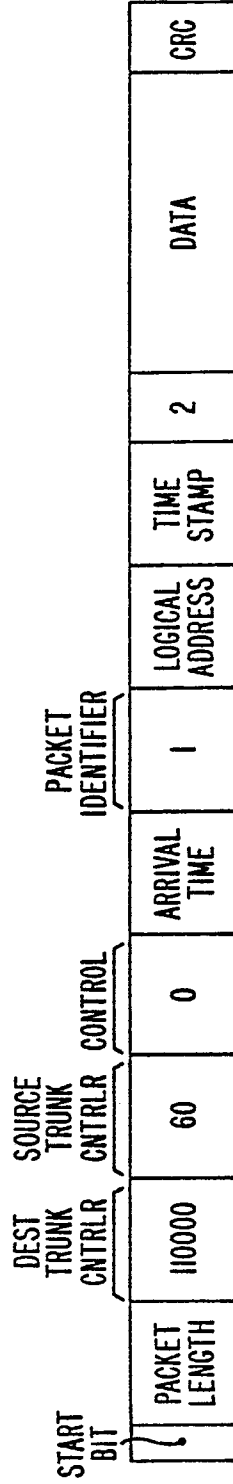

FIG. 7

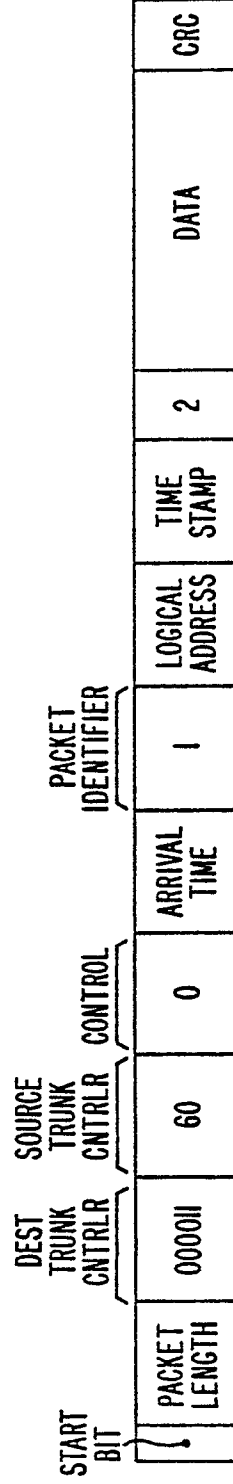

FIG. 8

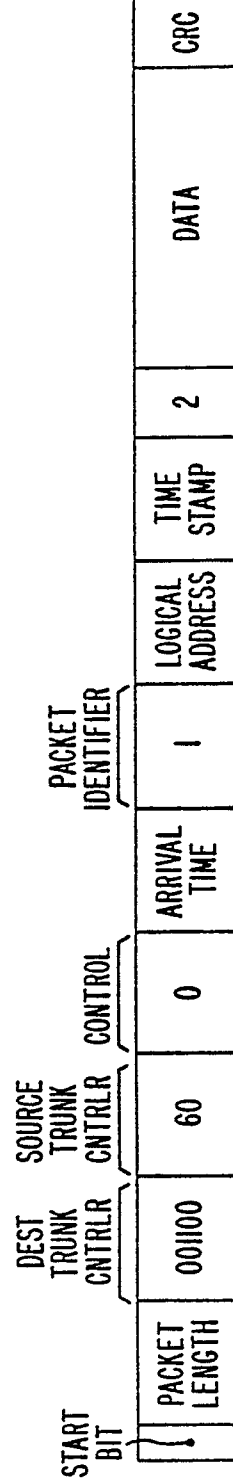

FIG. 9

FIG. 10

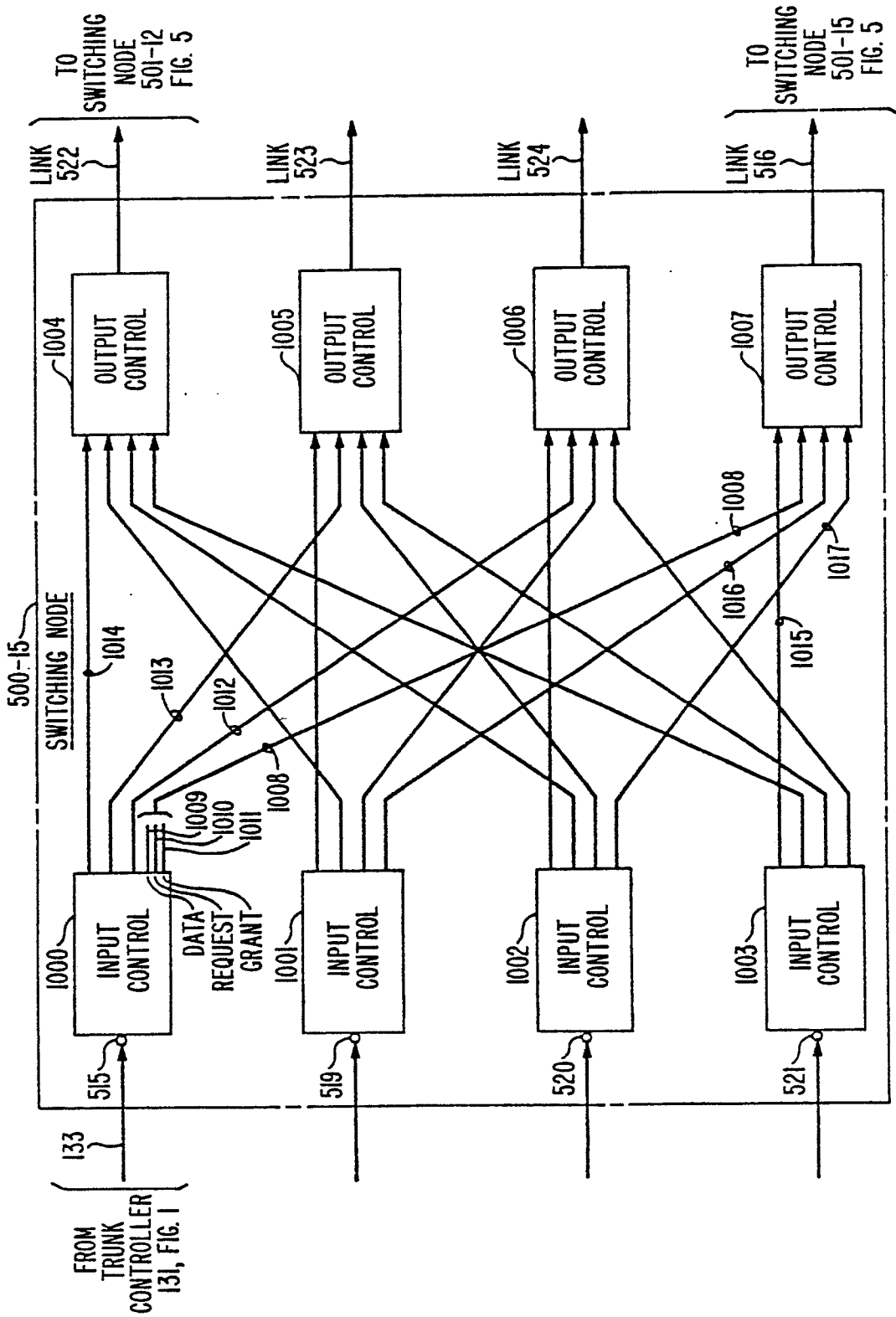

FIG. 11

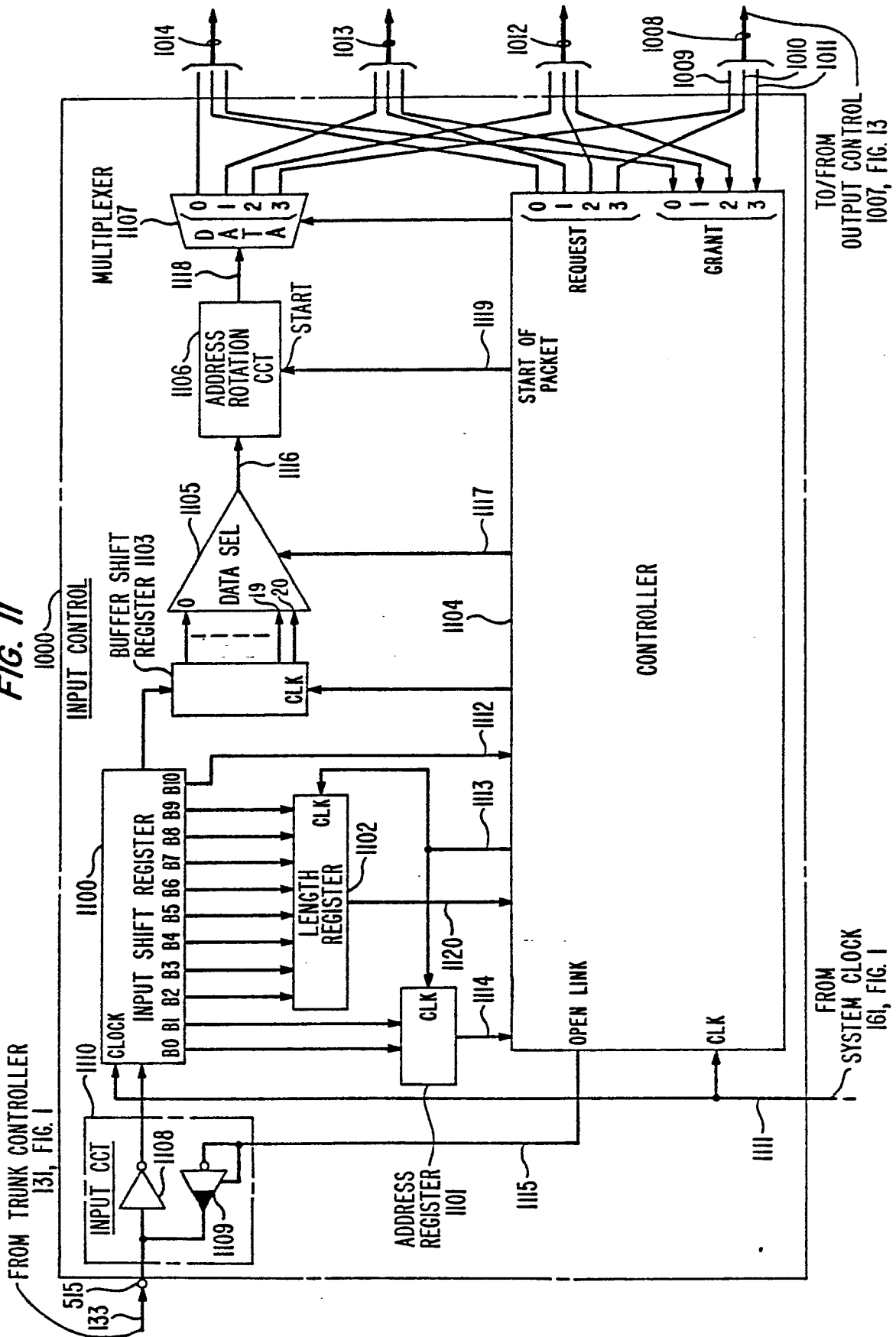

FIG. 12

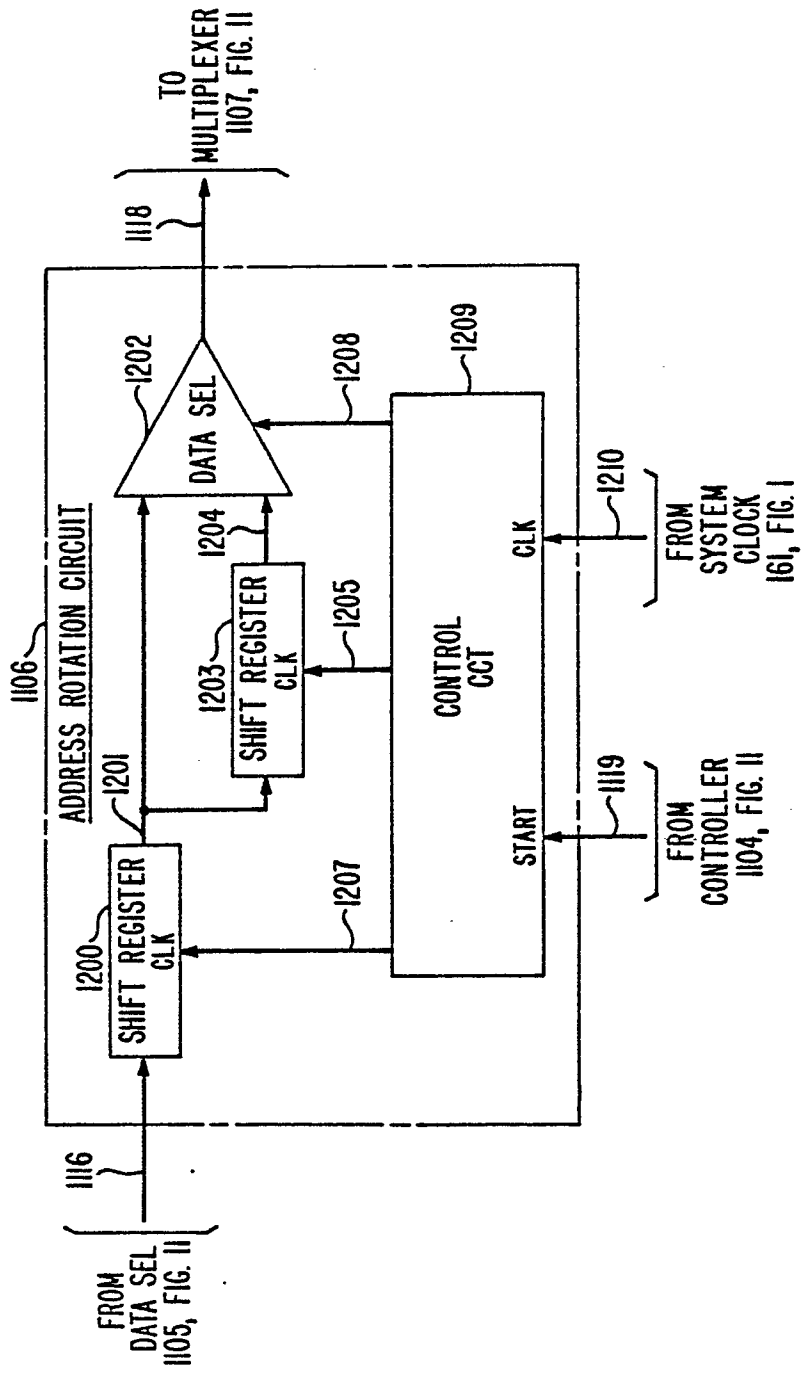
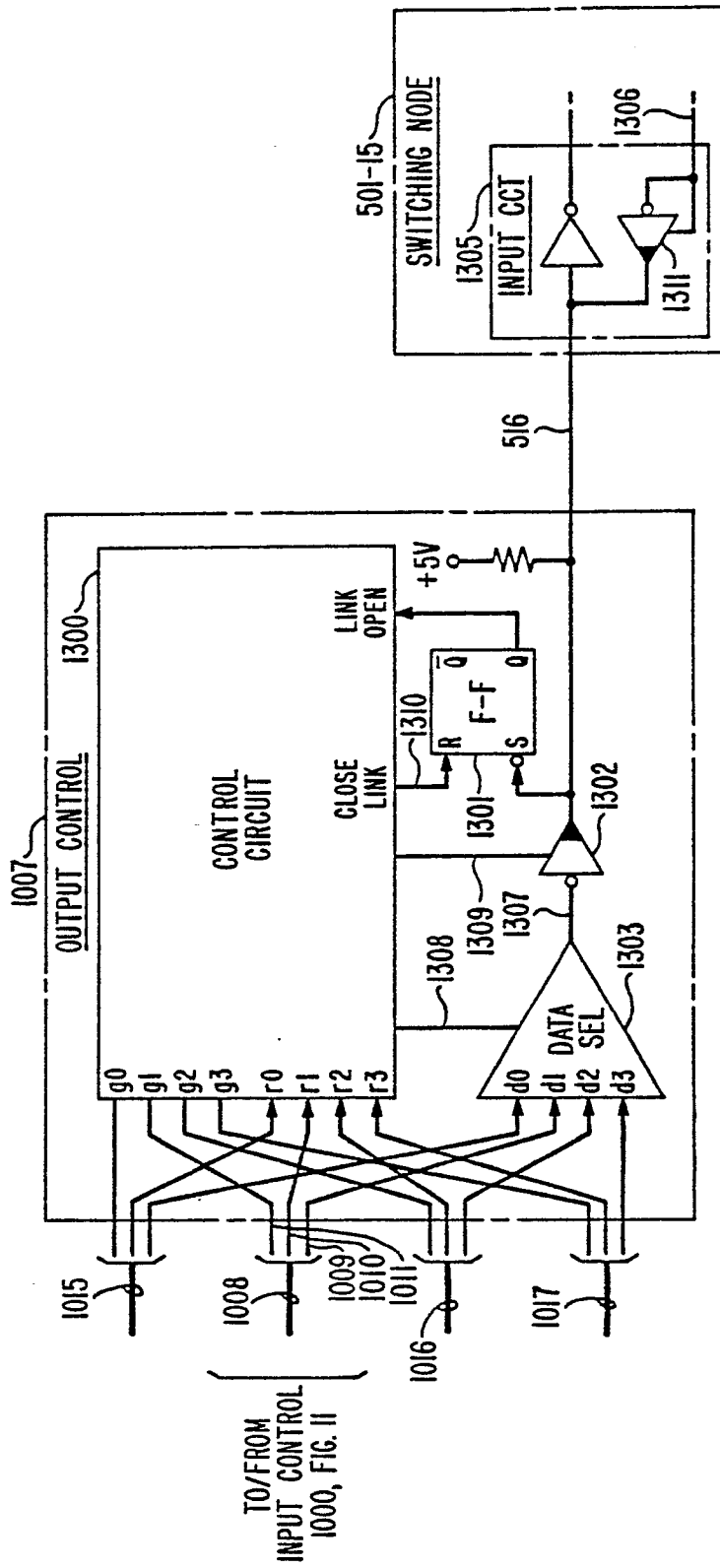
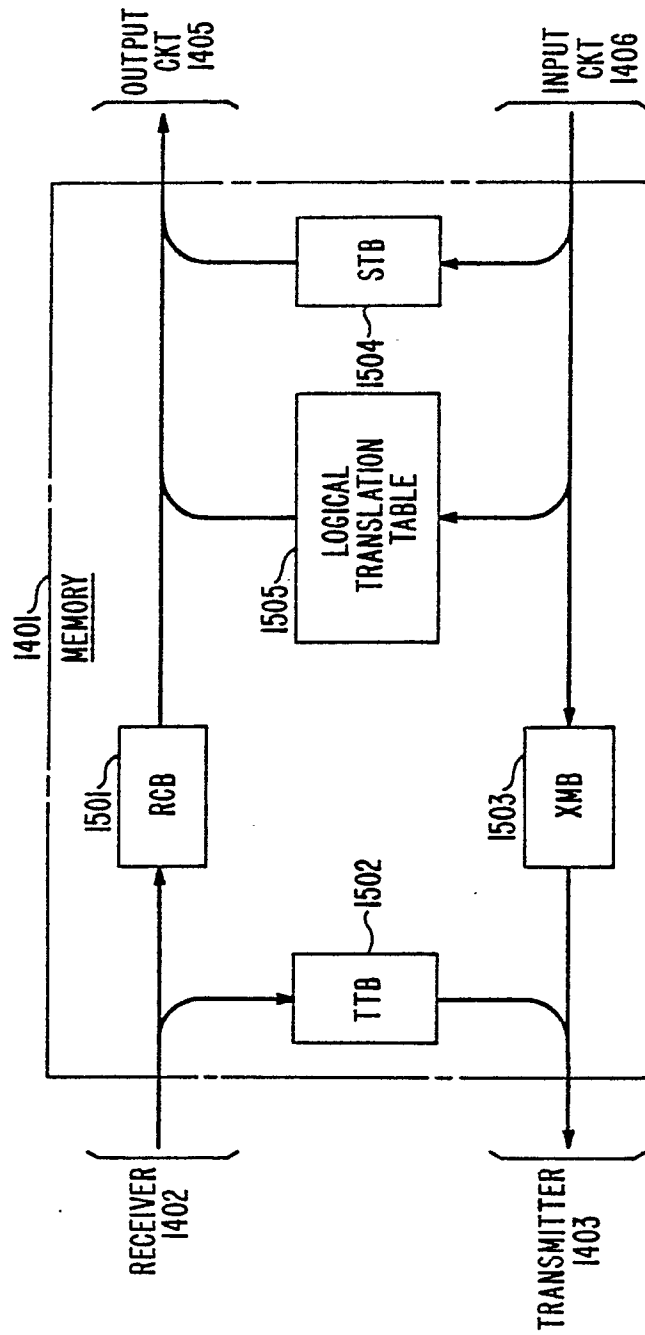

FIG. 13





MEMORY MAP
FIG. 15

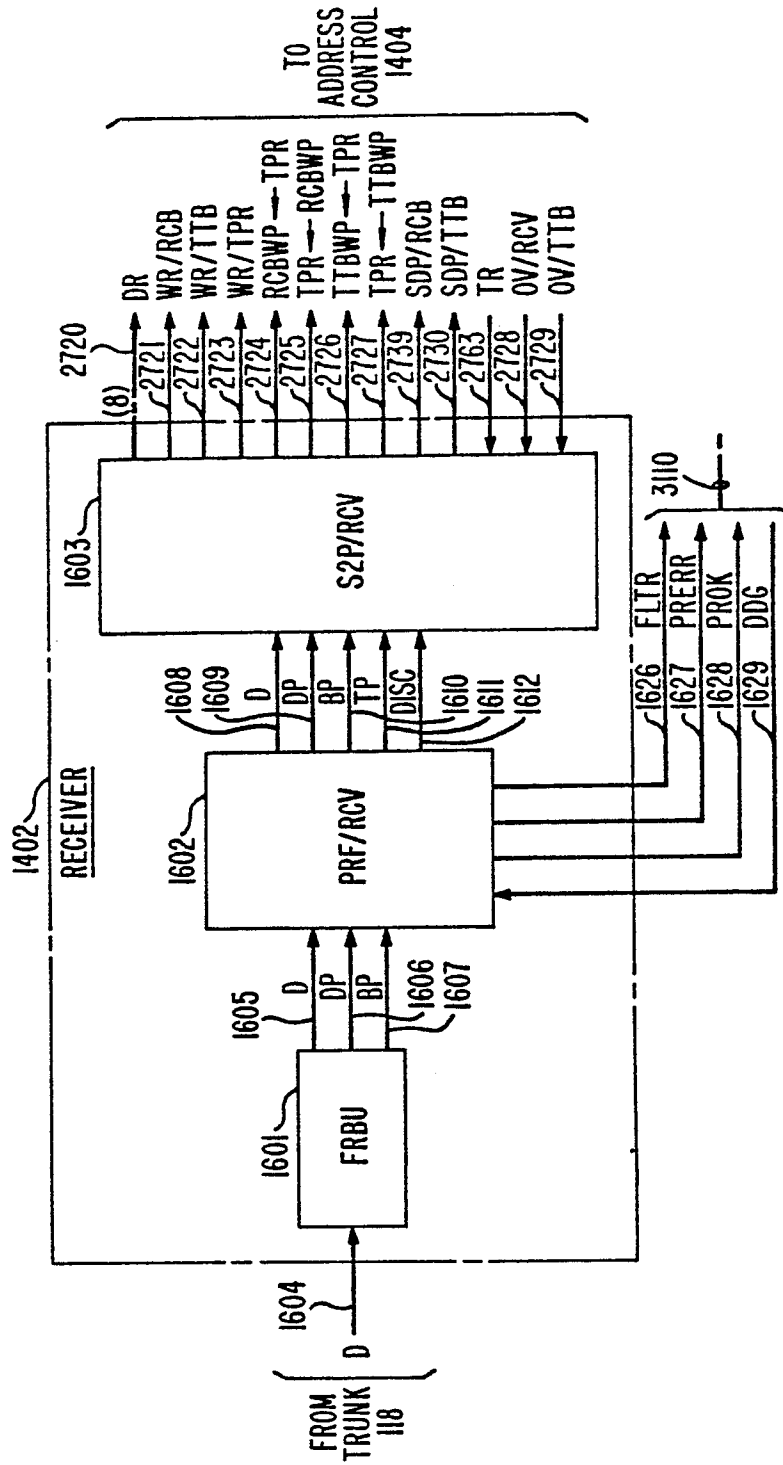

FIG. 16

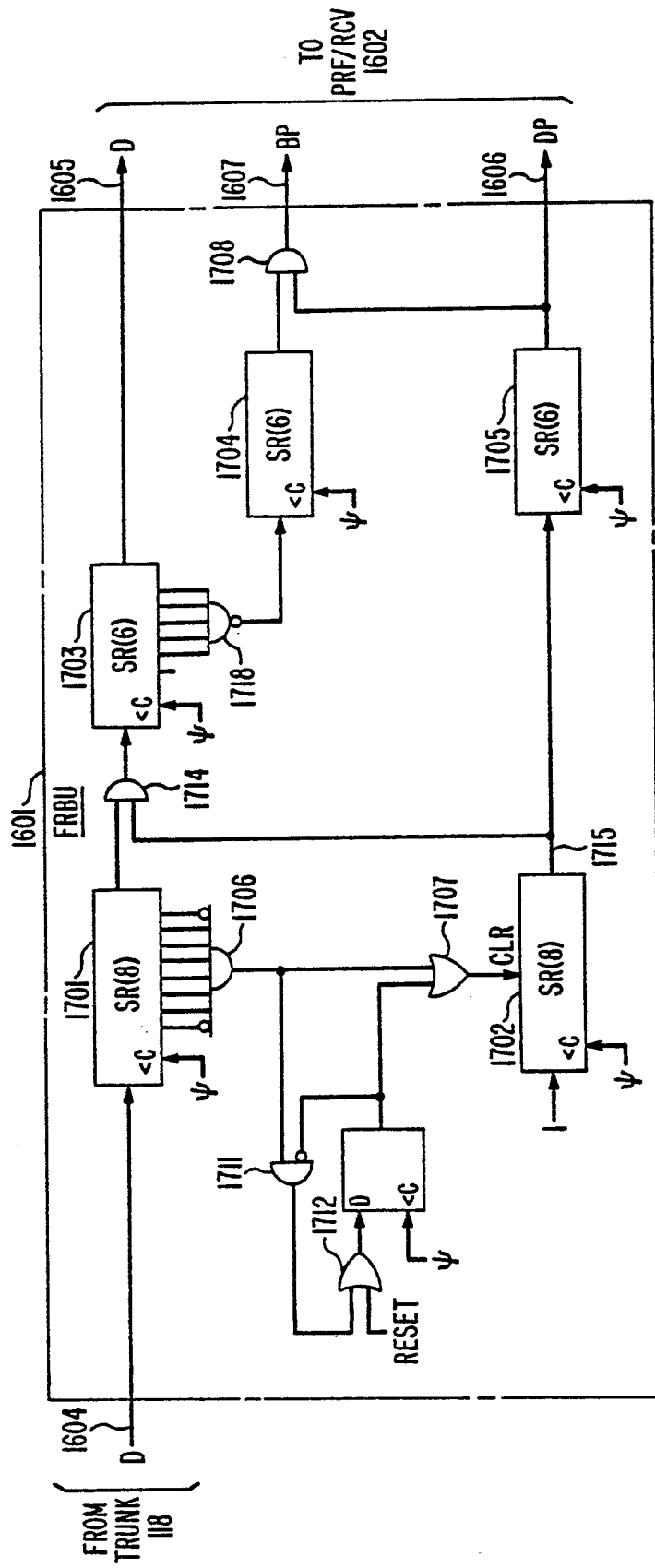

FIG. 17

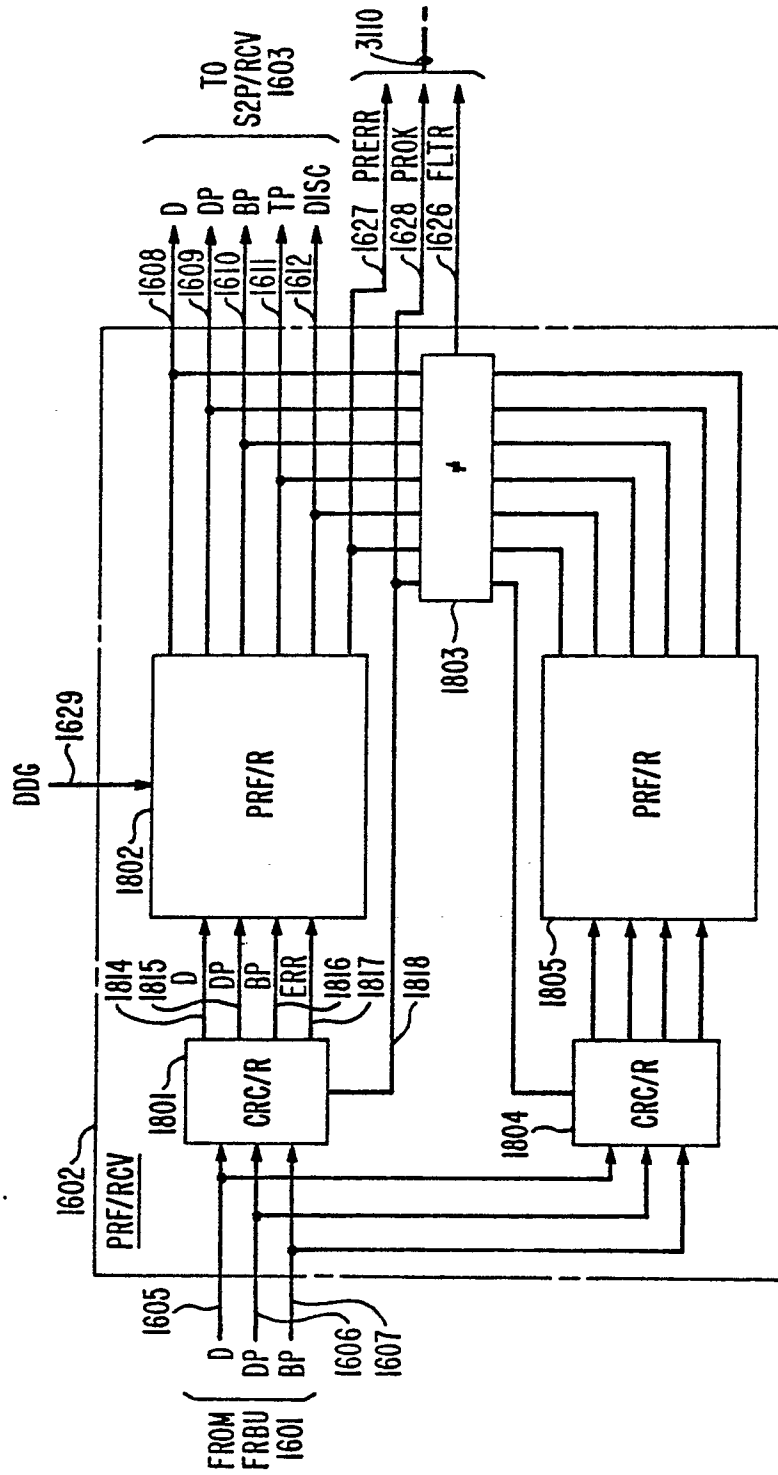

FIG. 18

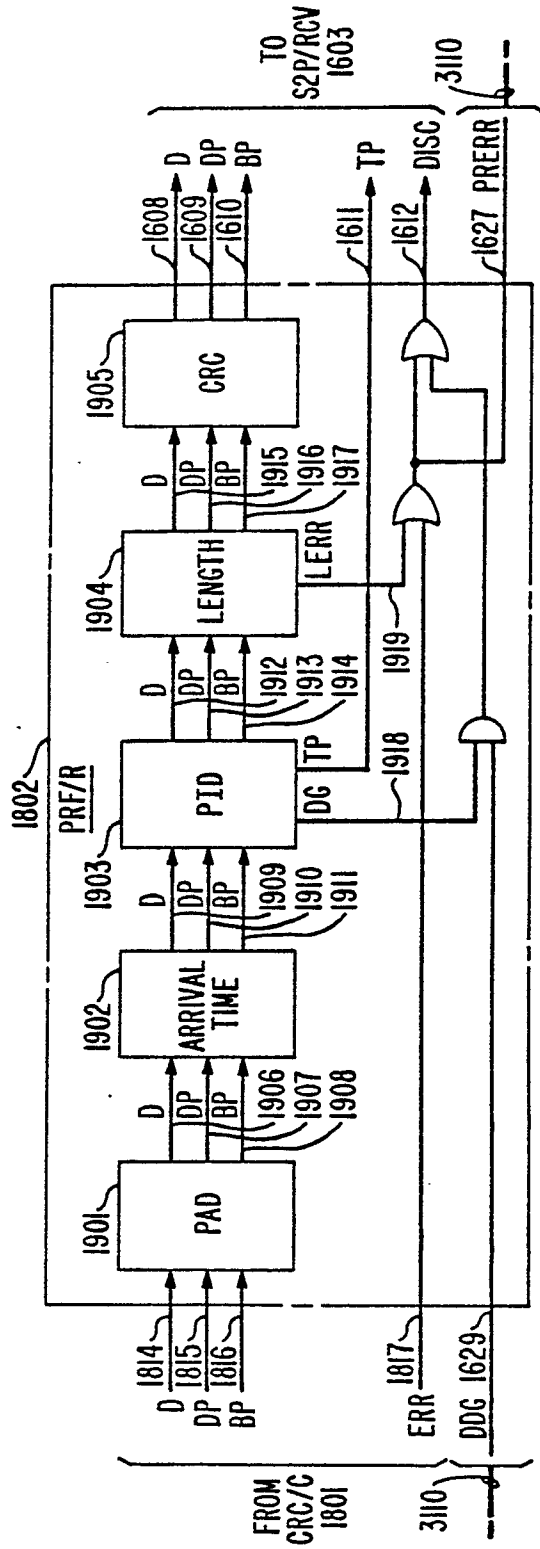

FIG. 19

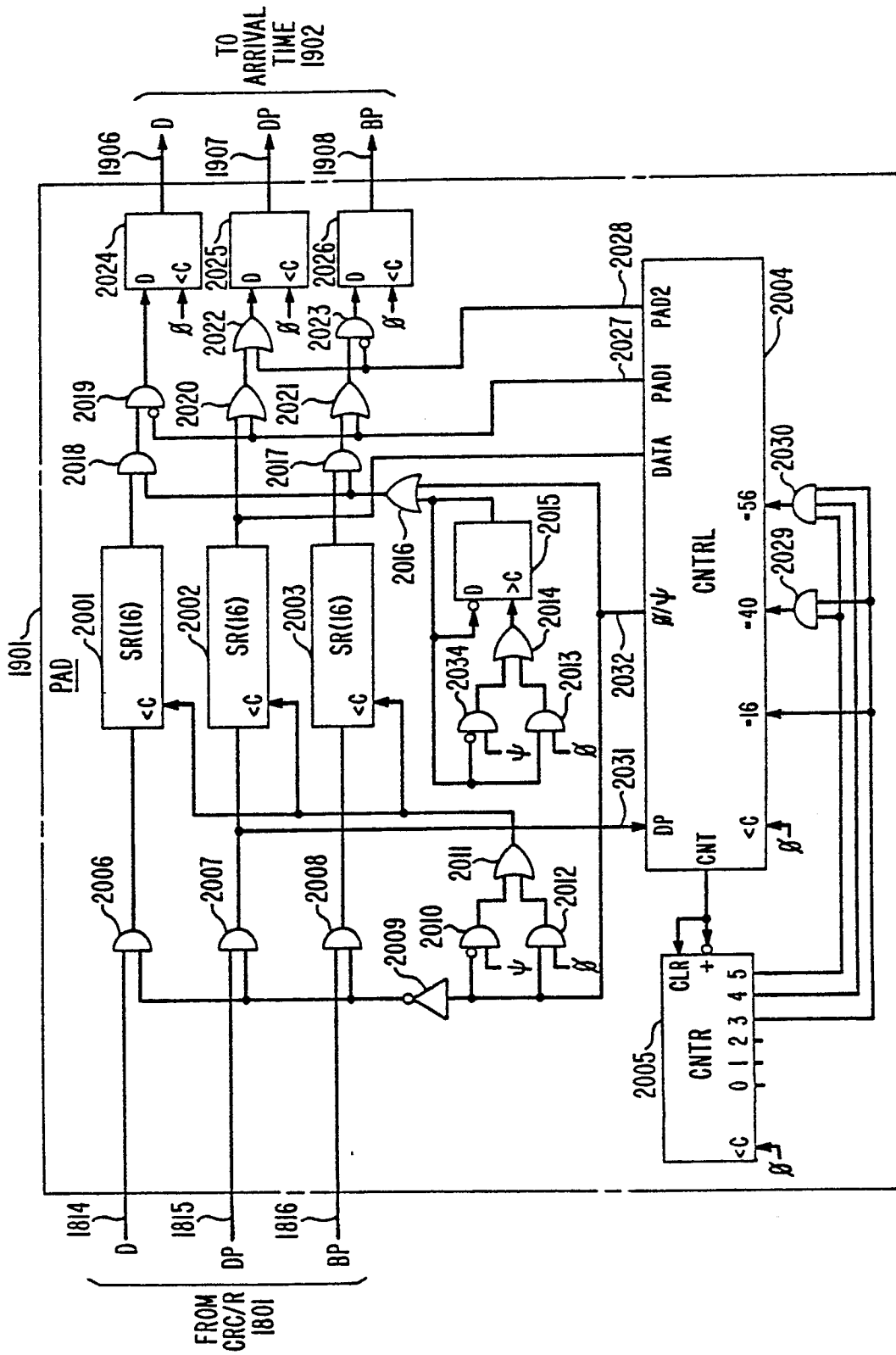

FIG. 20

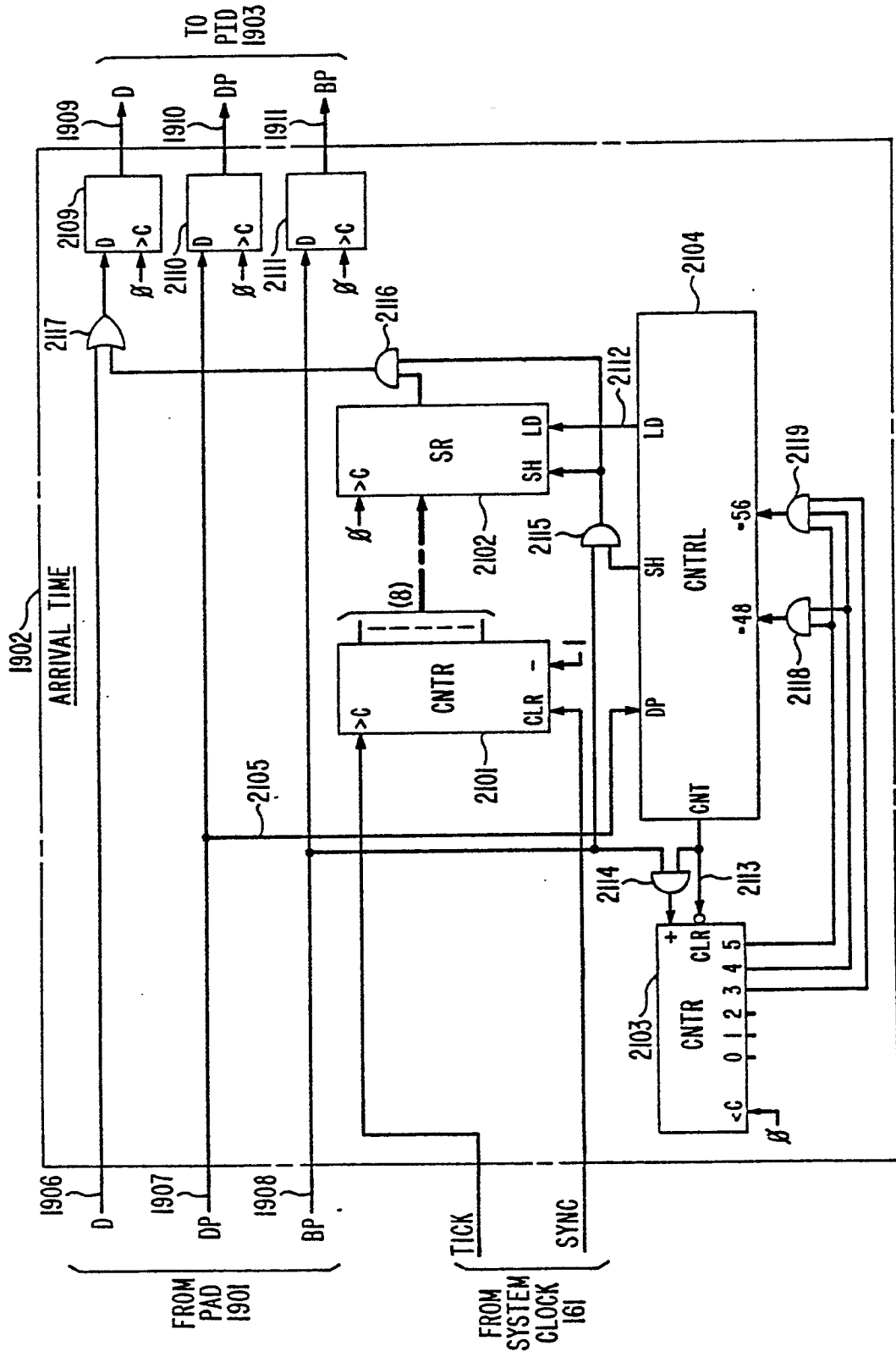

FIG. 21

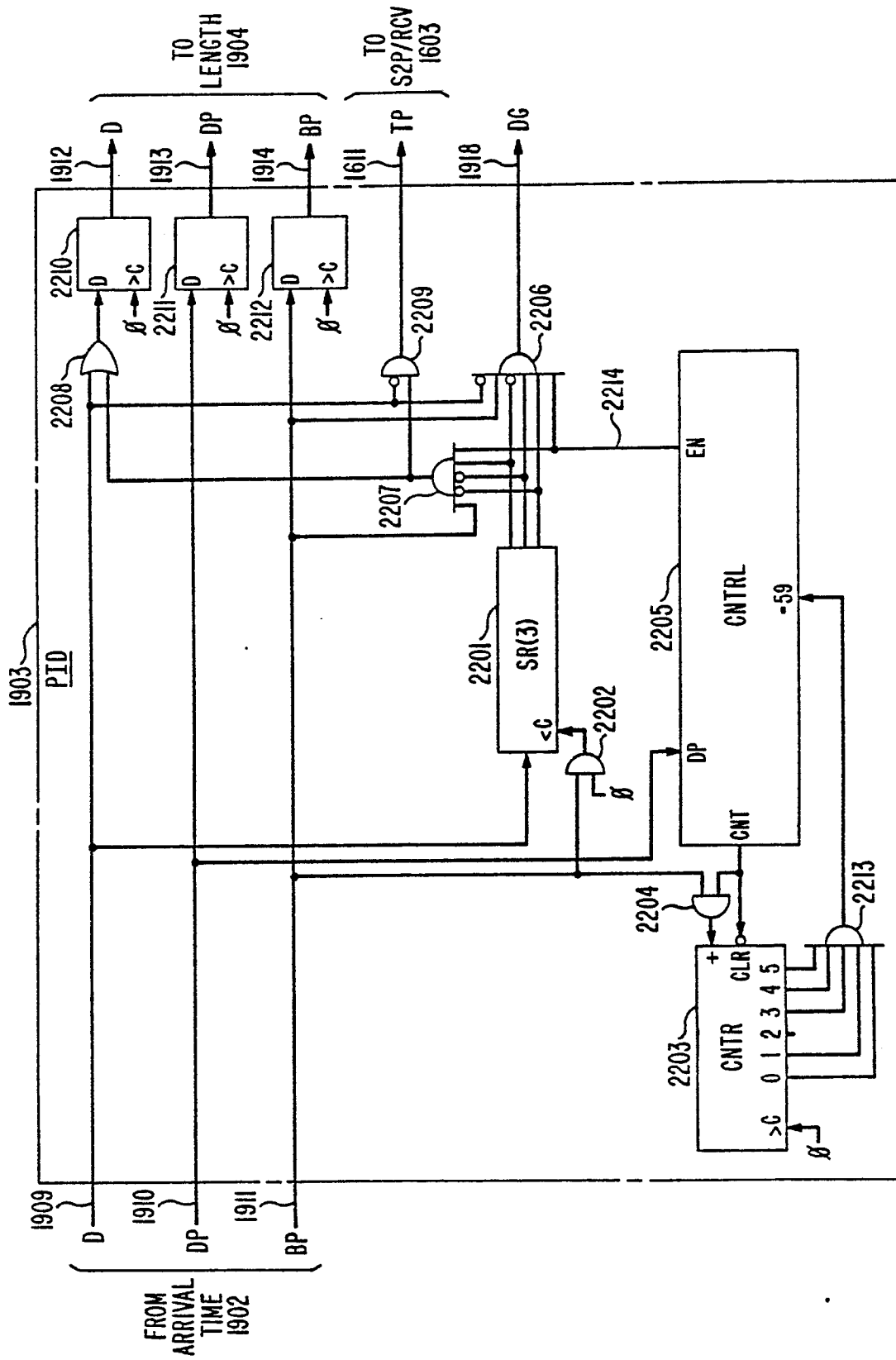

FIG. 22

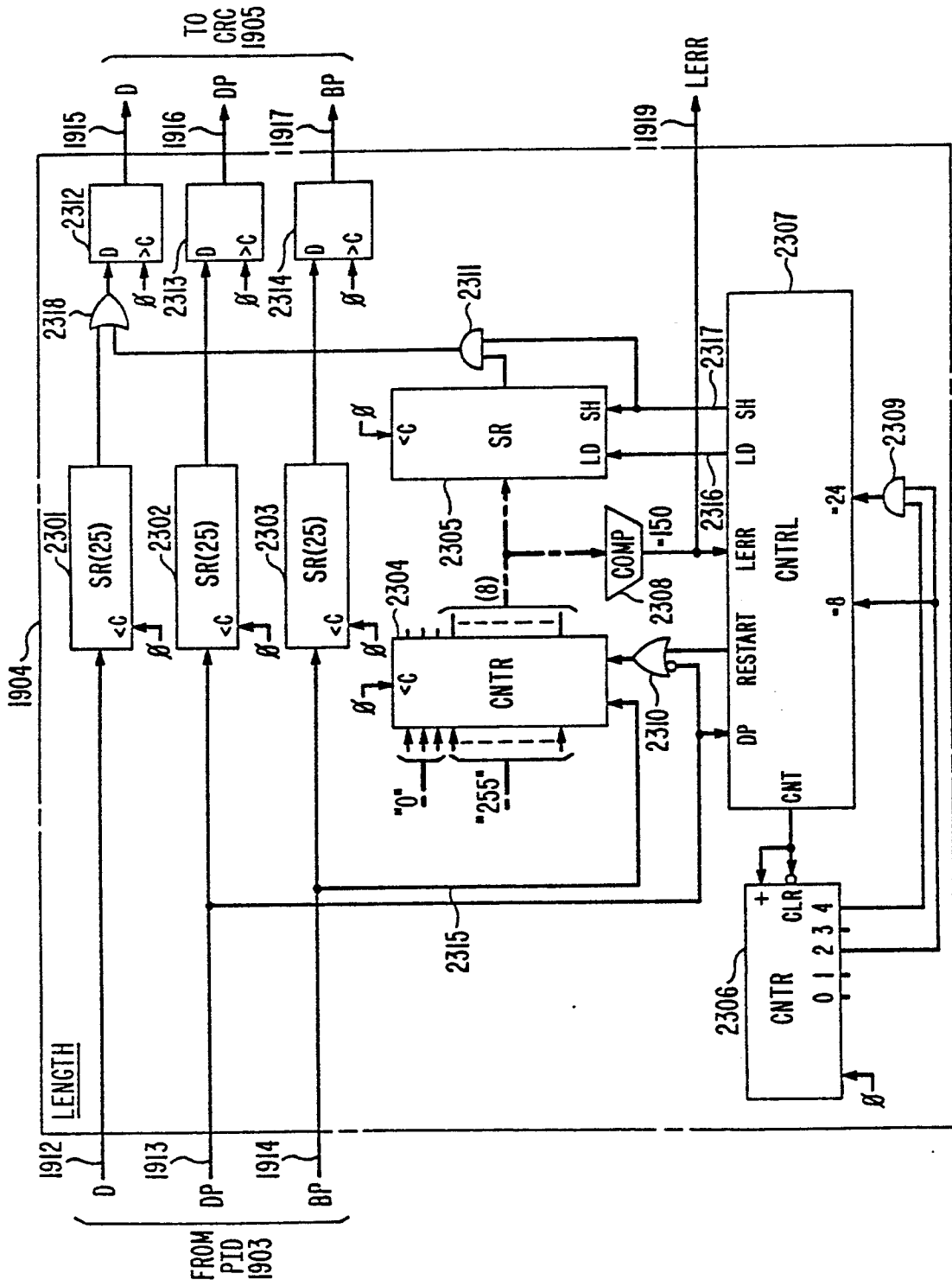

FIG. 23

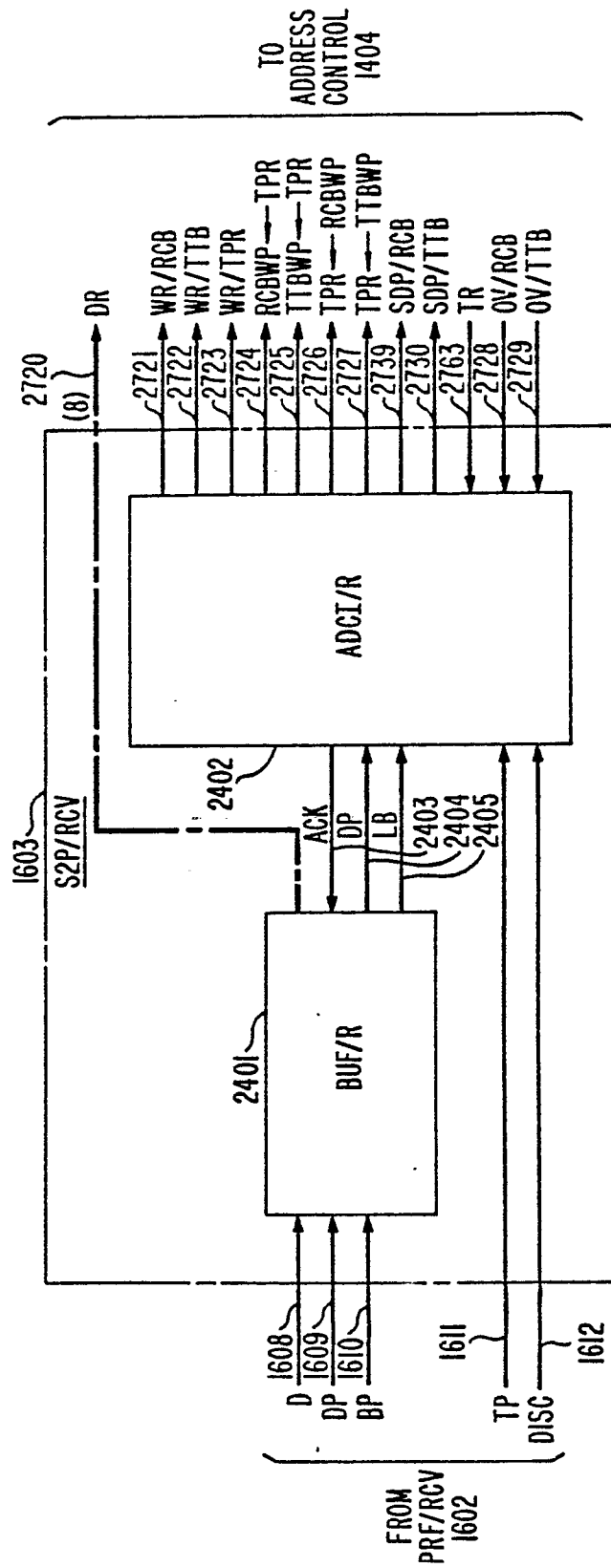

FIG. 24

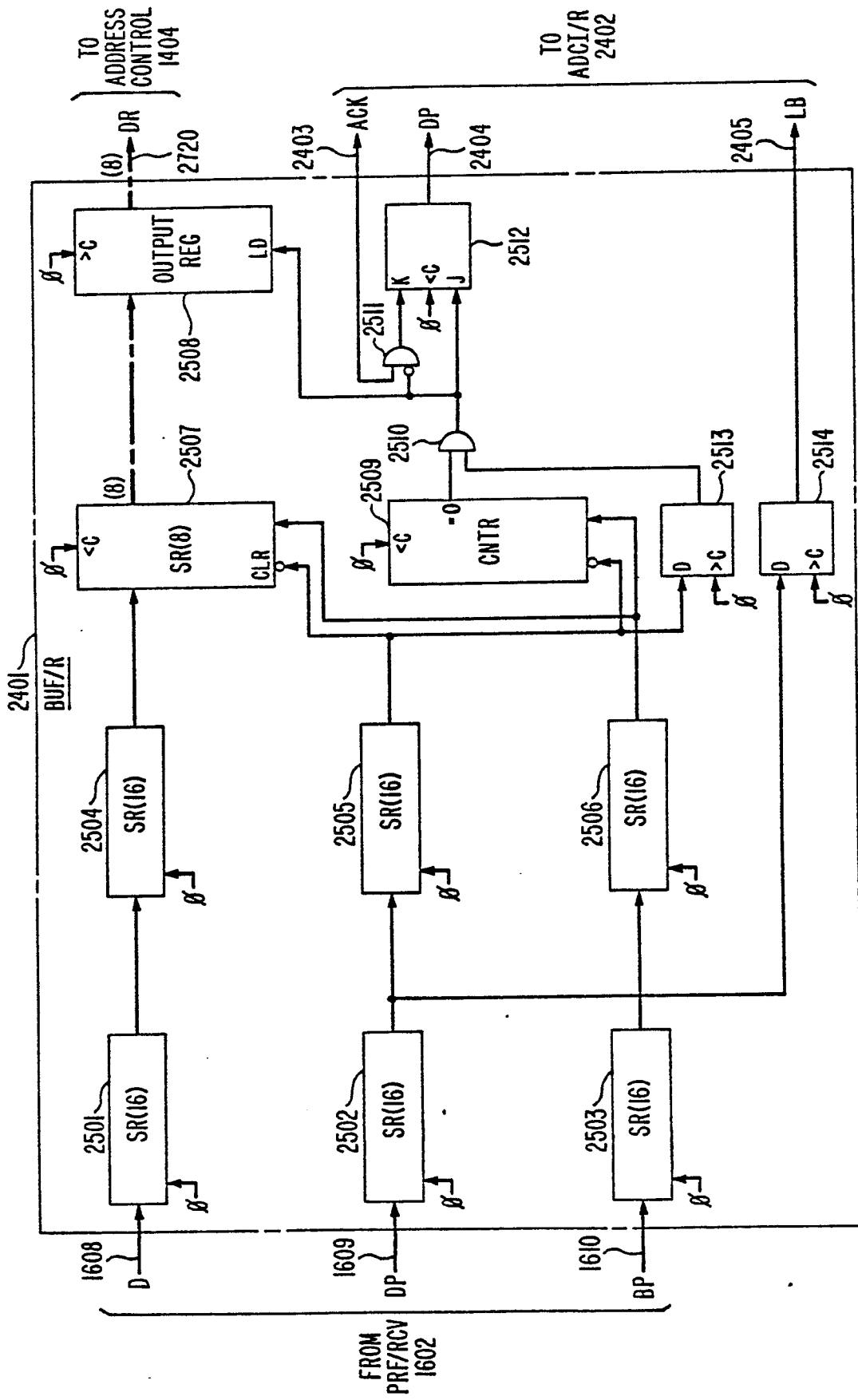

FIG. 25

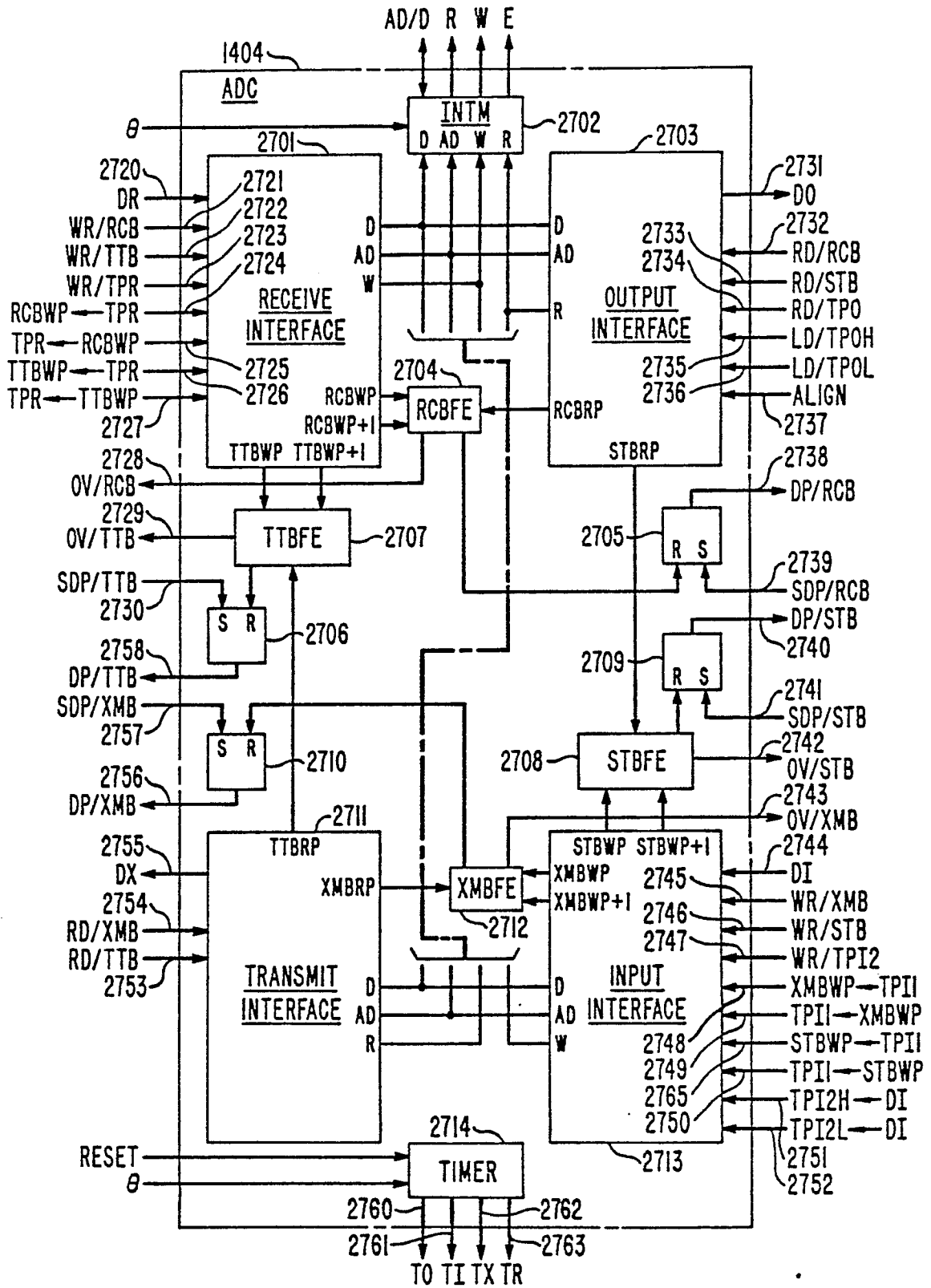

FIG. 27

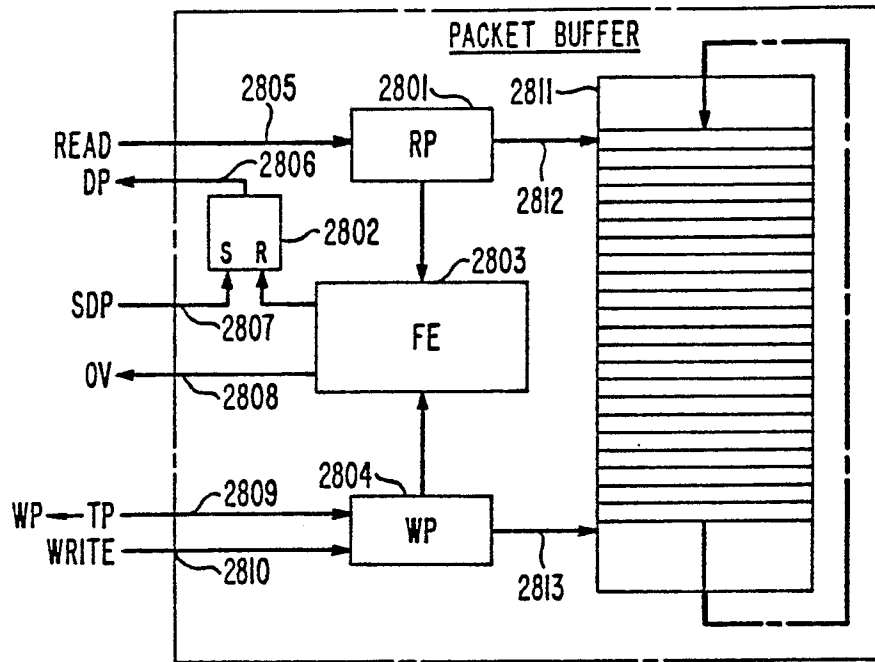

FIG. 28

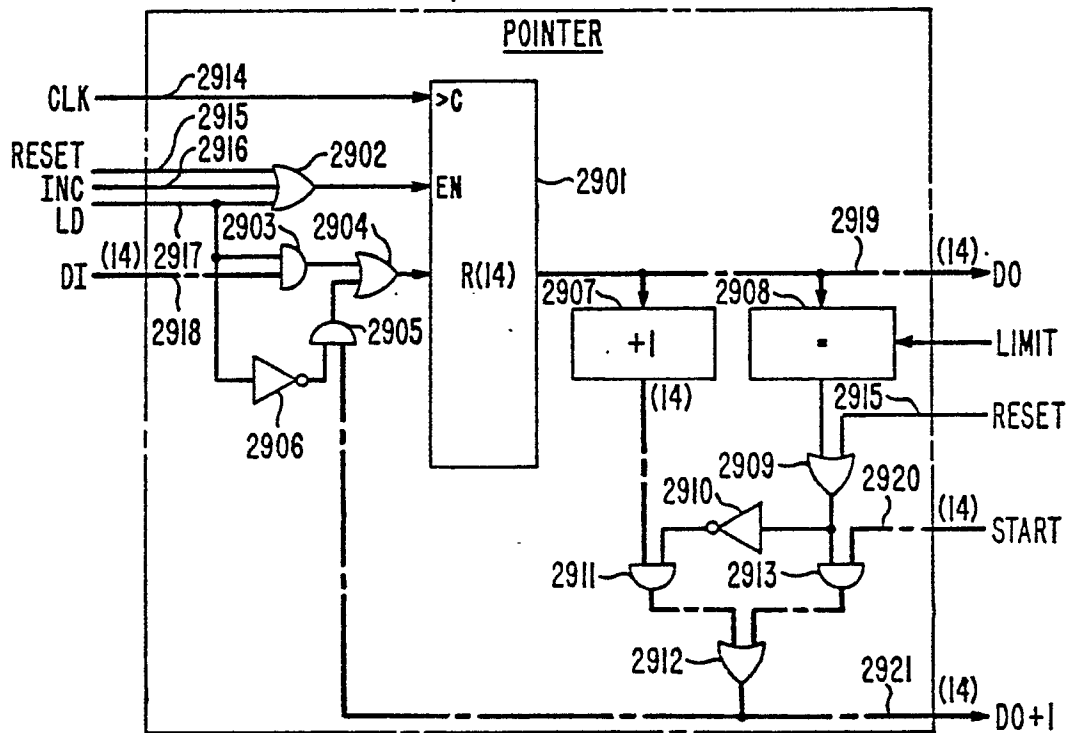

FIG. 29

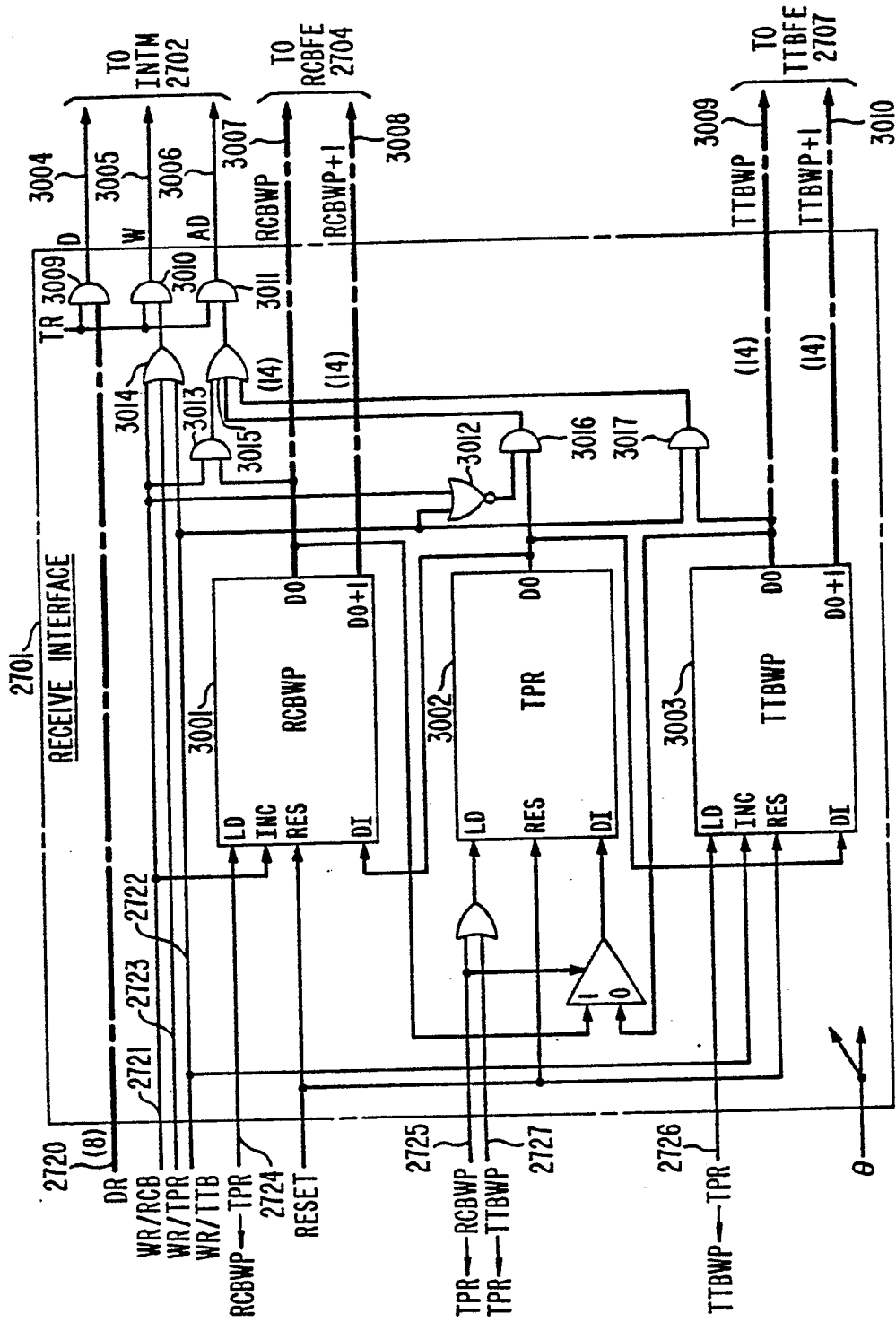

FIG. 30

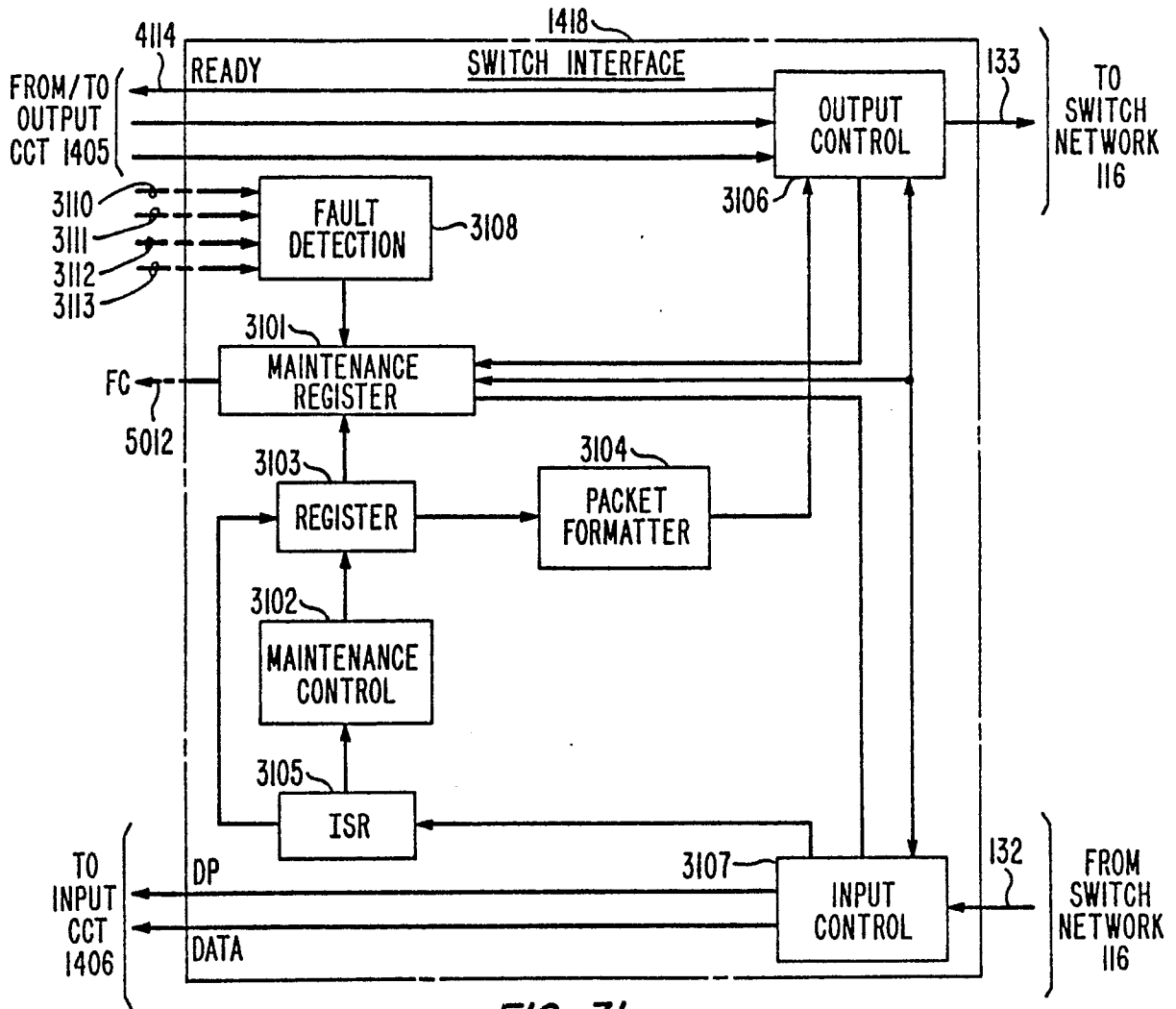

FIG. 31

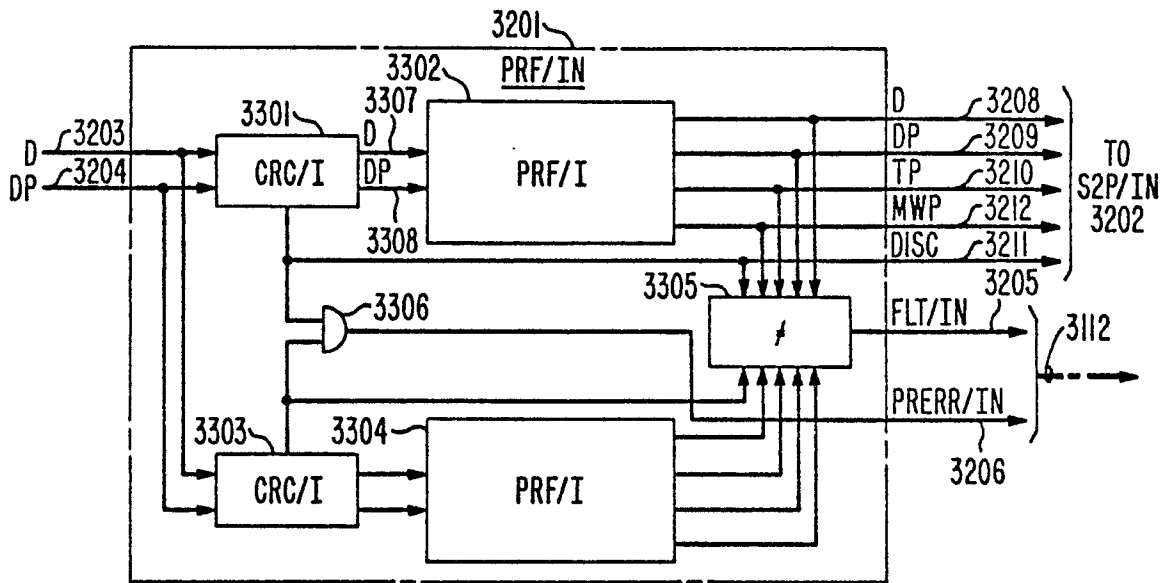

FIG. 33

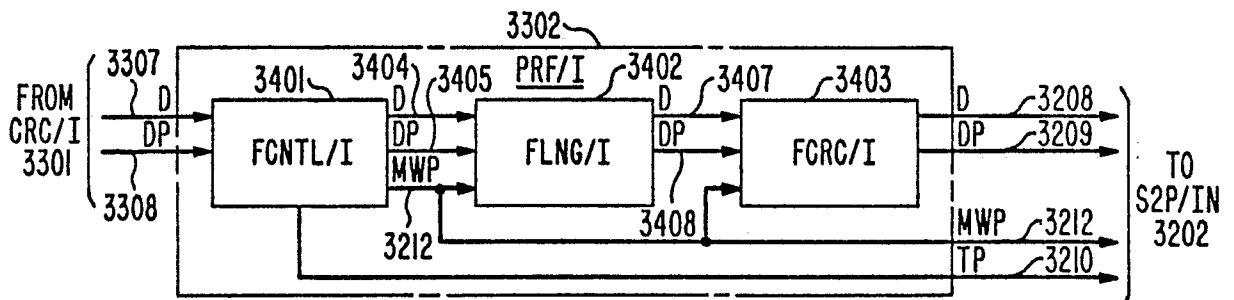

FIG. 34

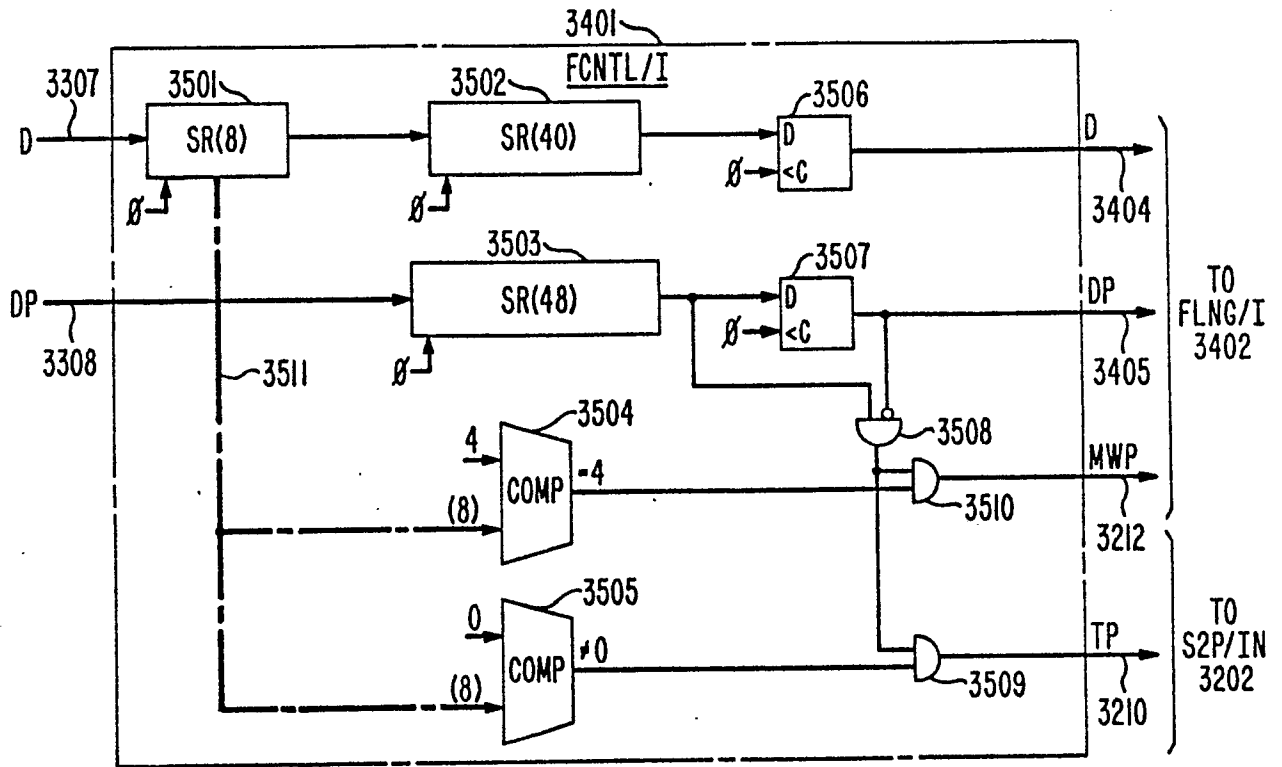

FIG. 35

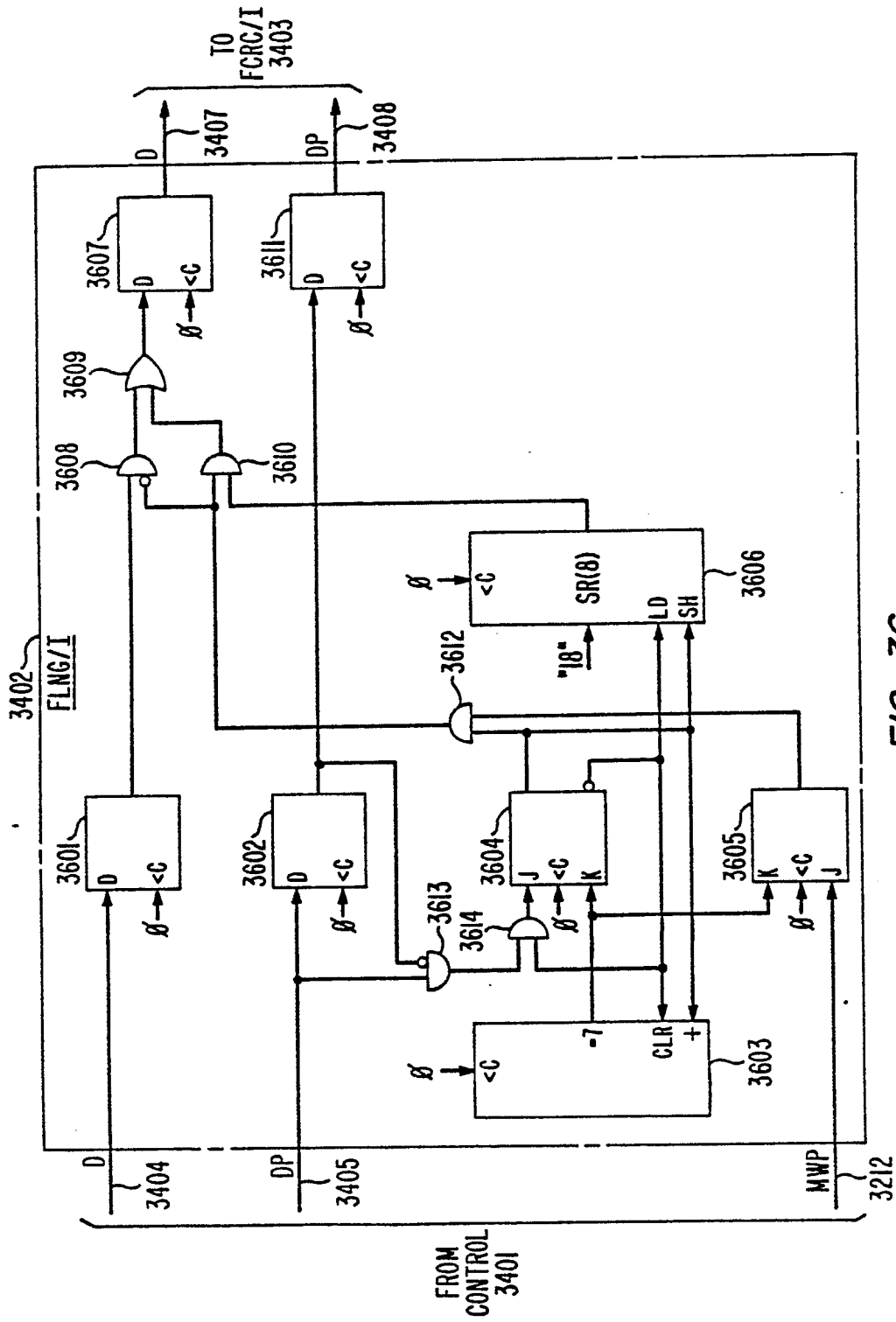

FIG. 36

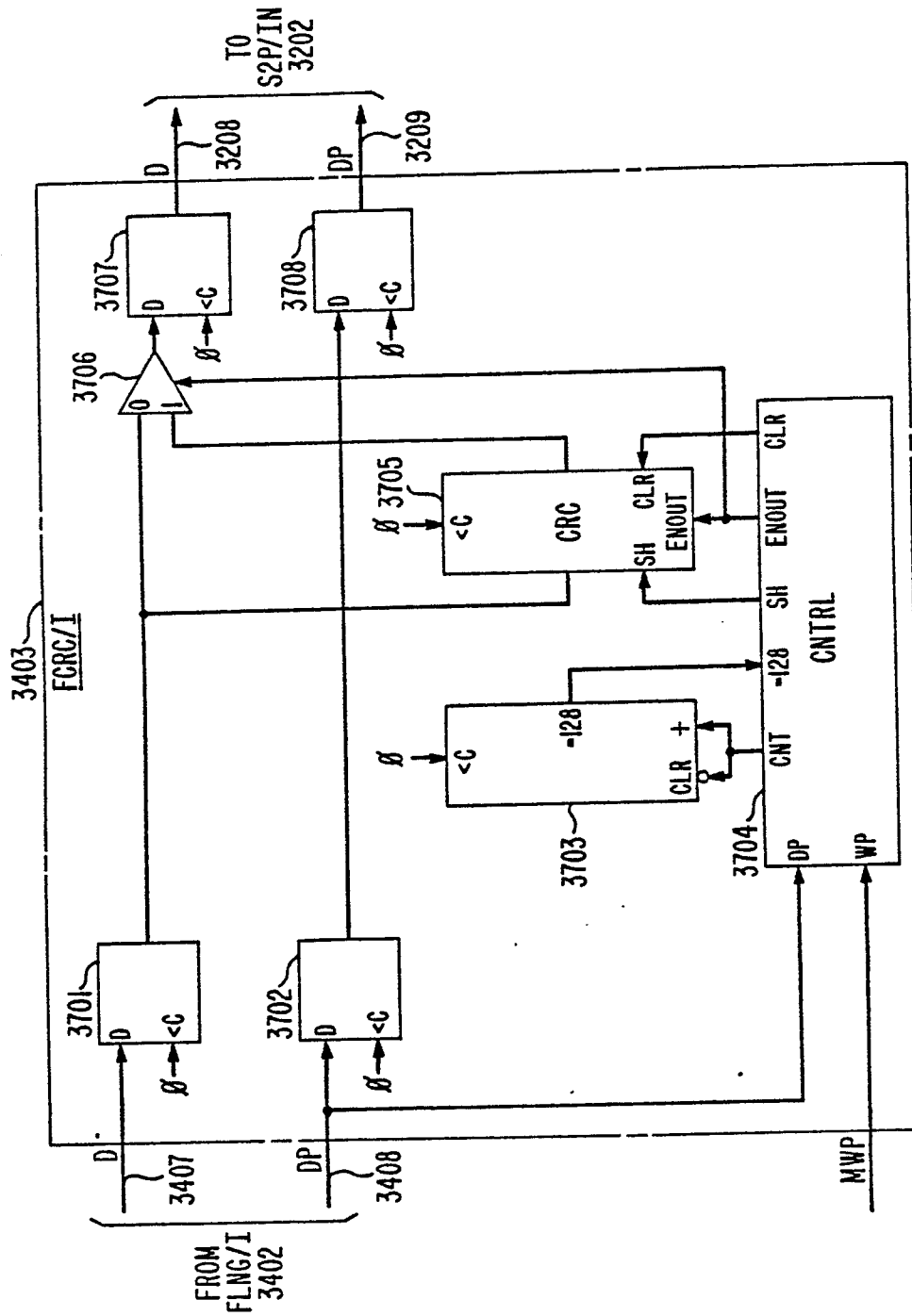

FIG. 37

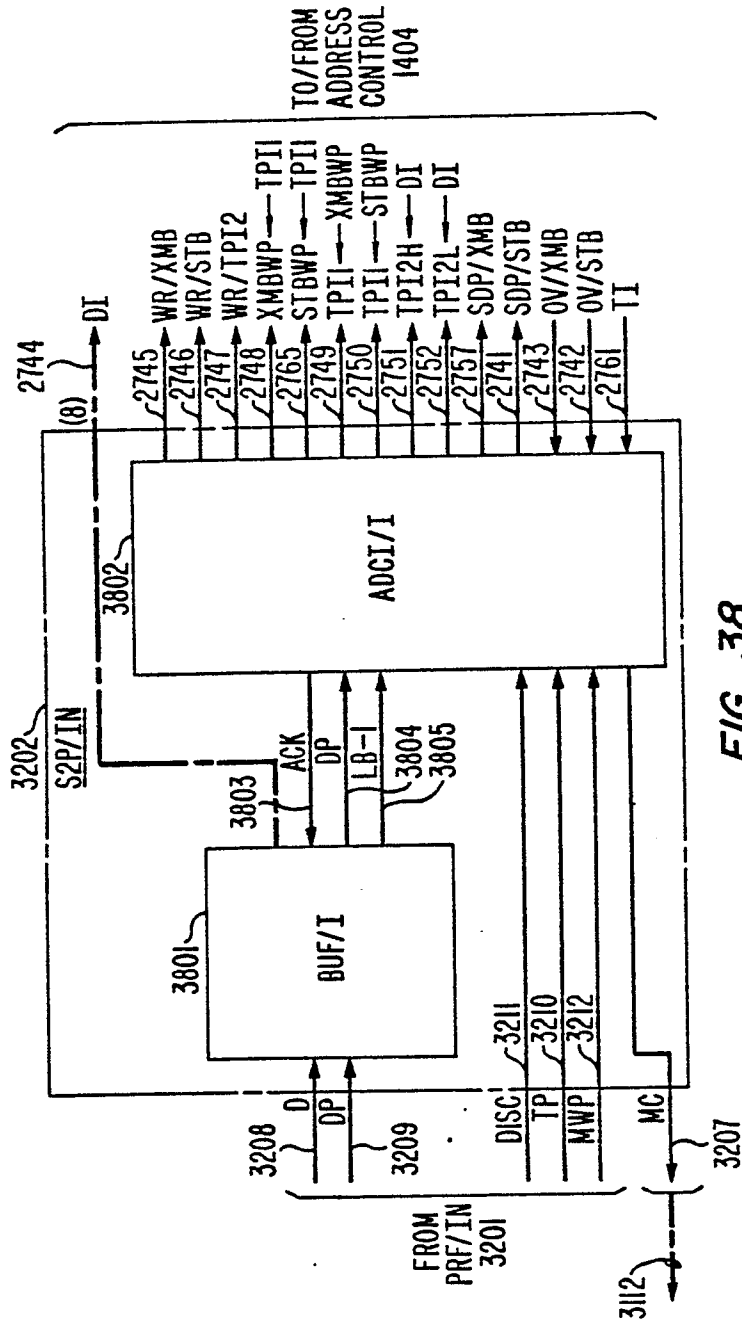

FIG. 38

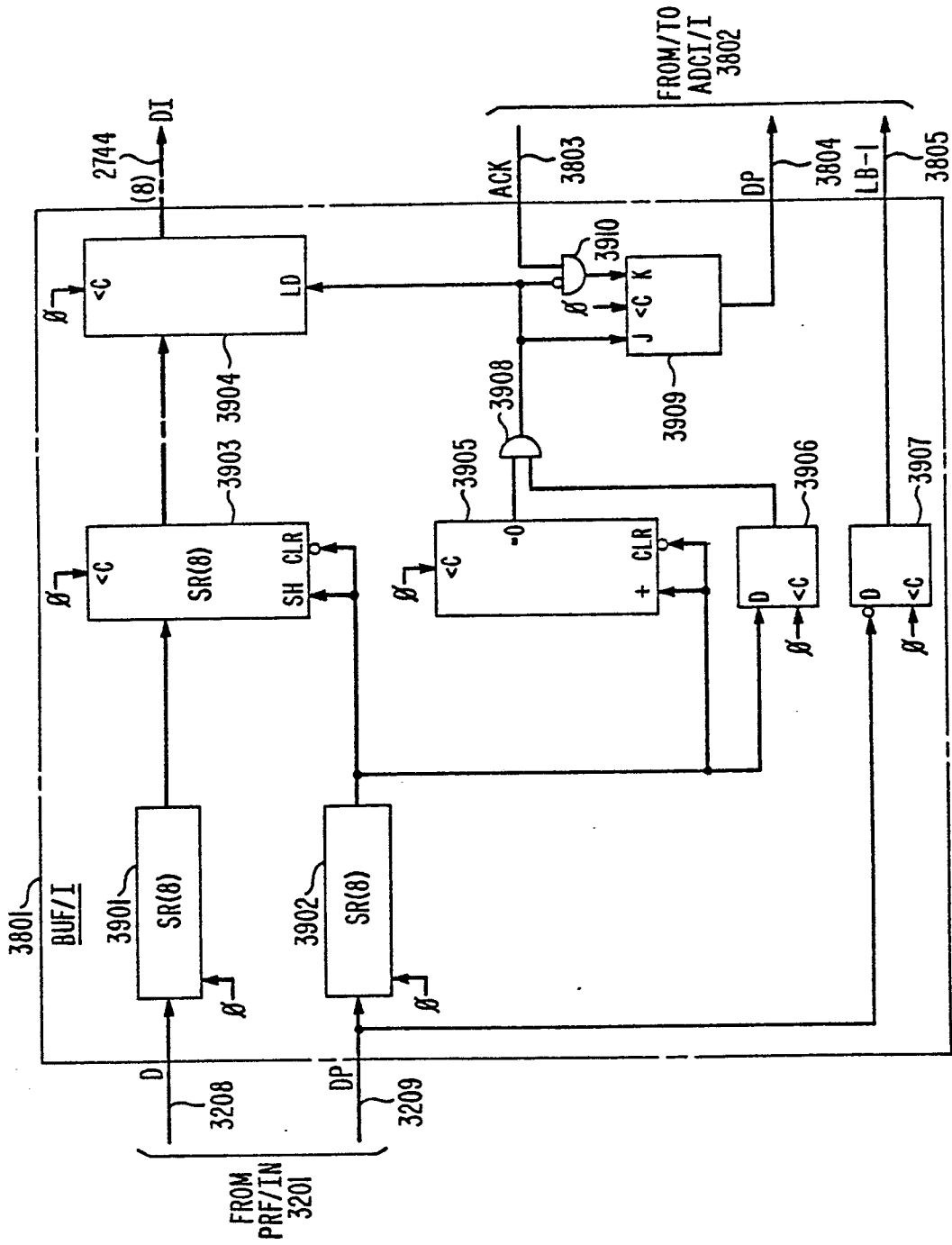

FIG. 39

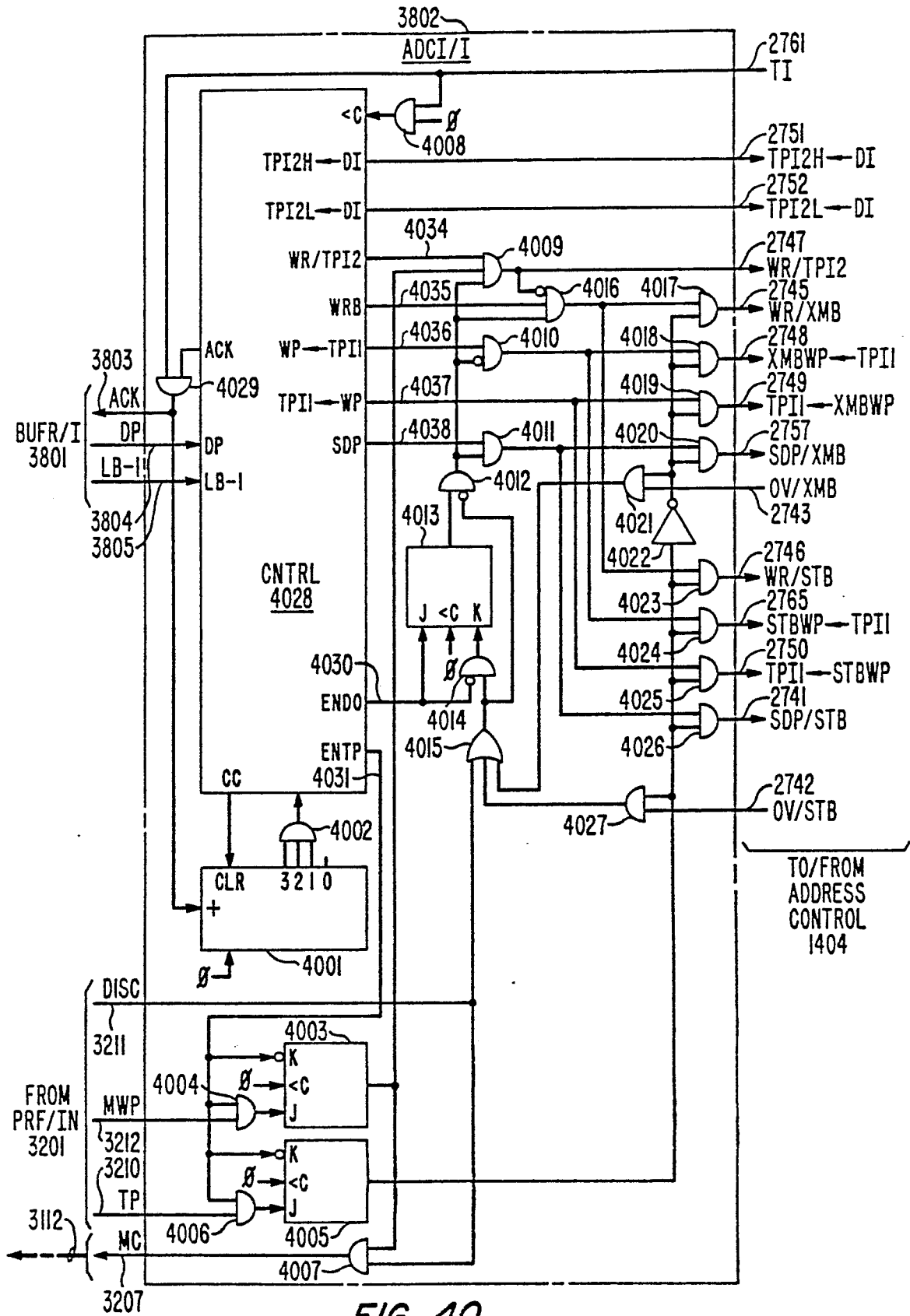

FIG. 40

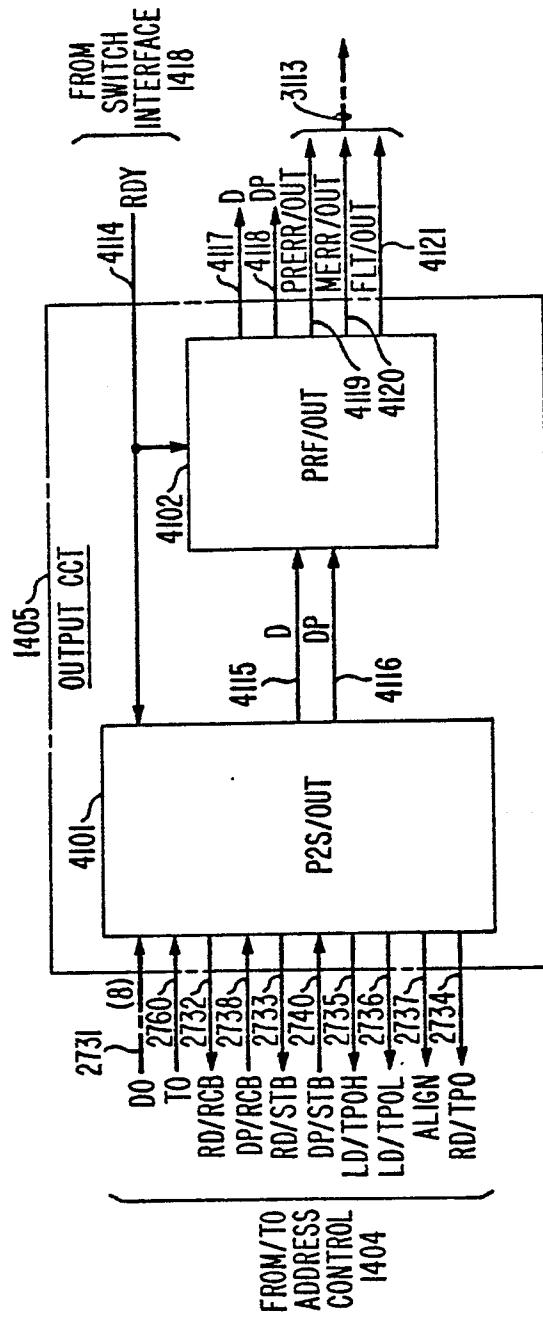

FIG. 41

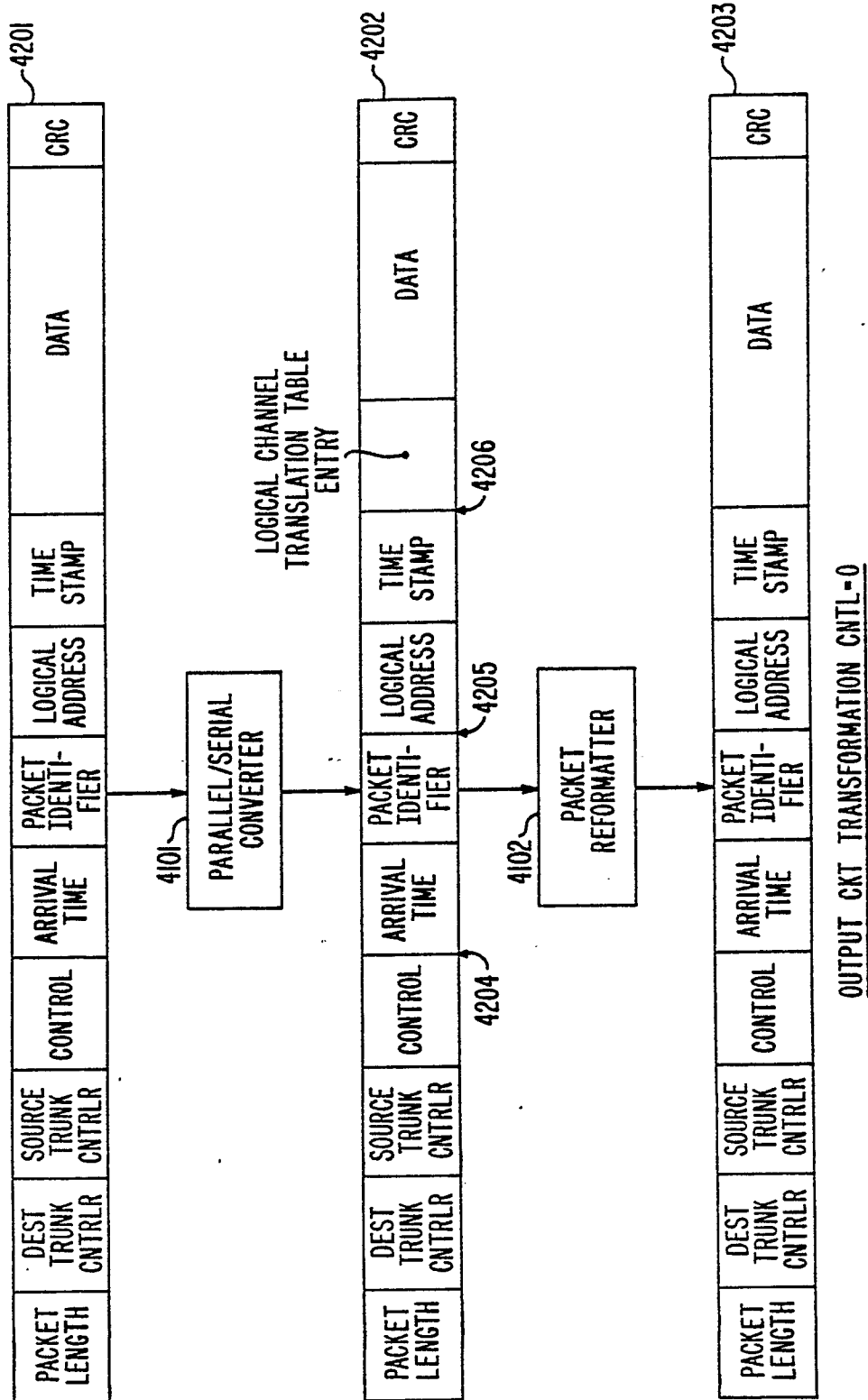

FIG. 42

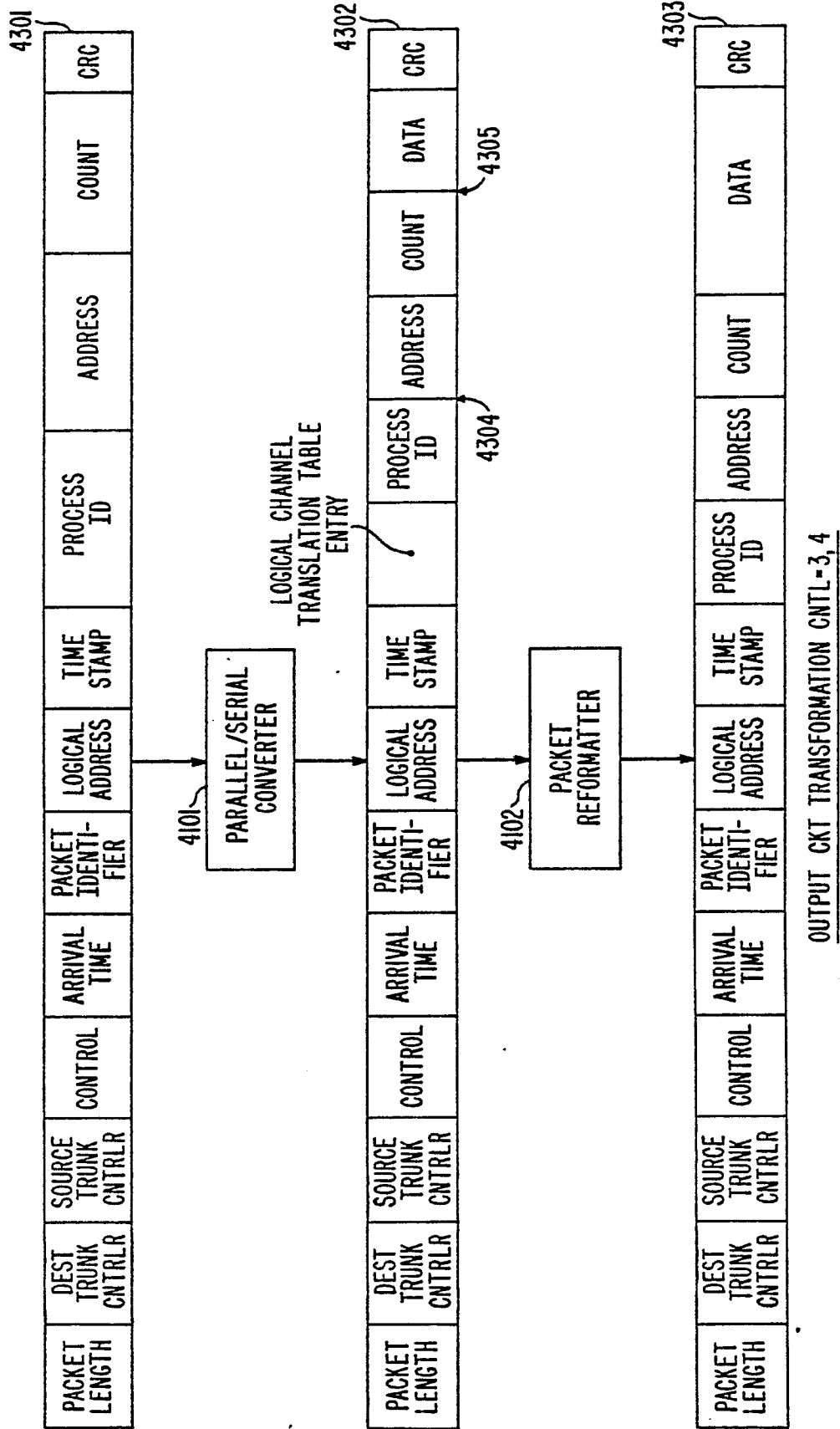
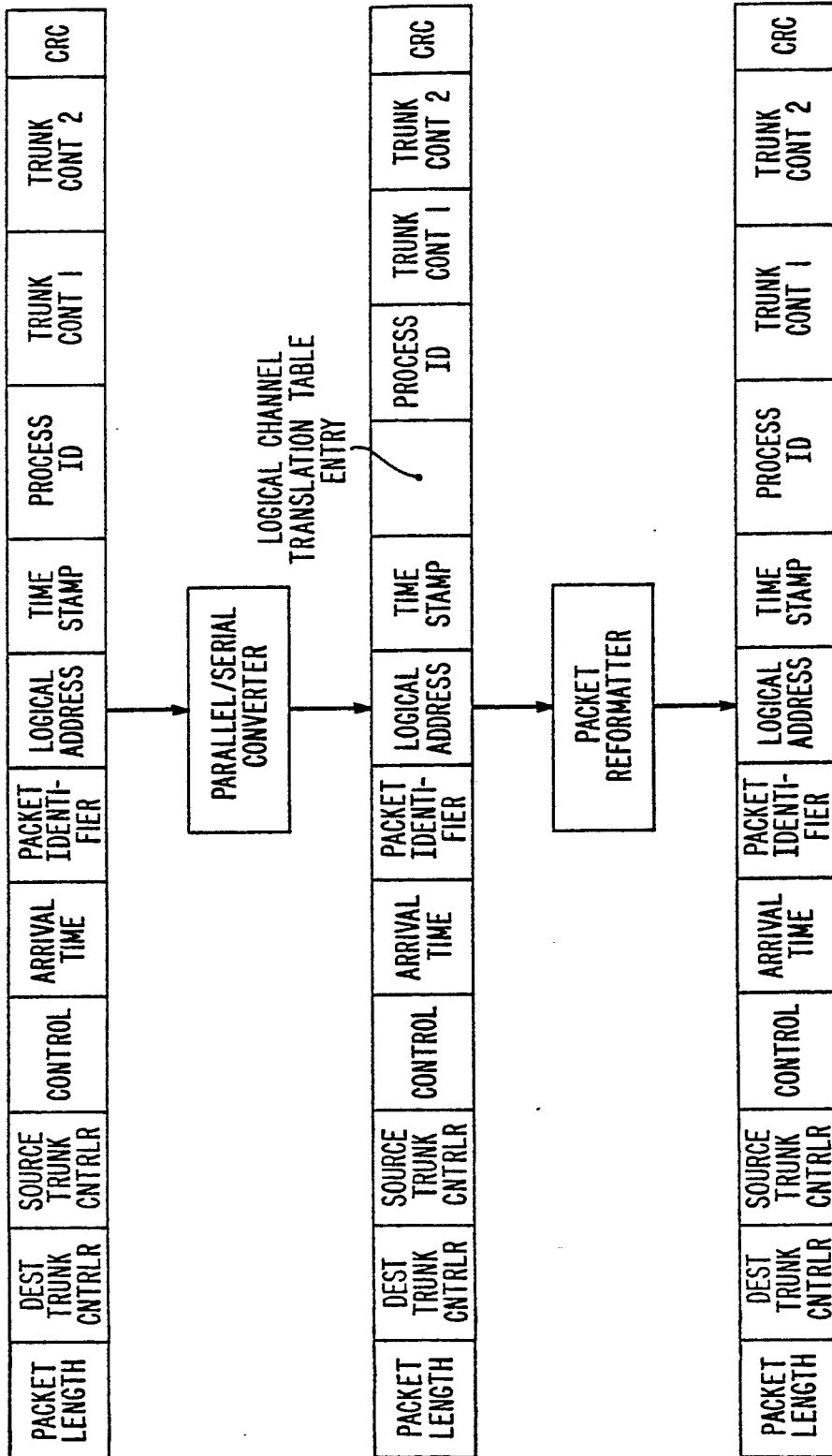

FIG. 43



OUTPUT PKT TRANSFORMATION CNTL -5,6

FIG. 44

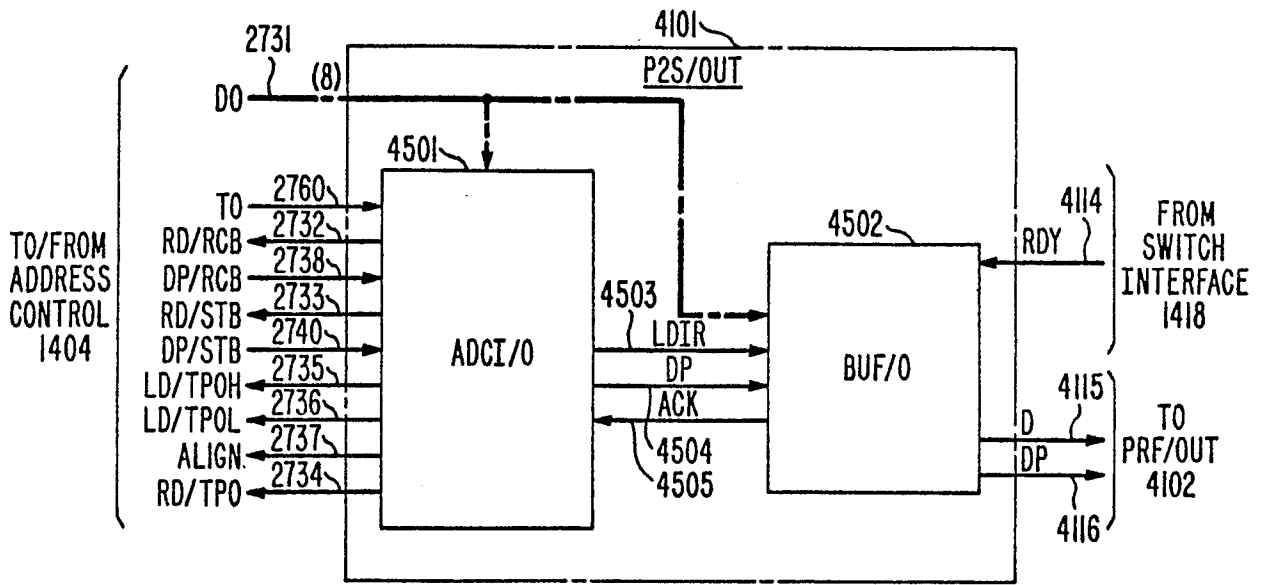

FIG. 45

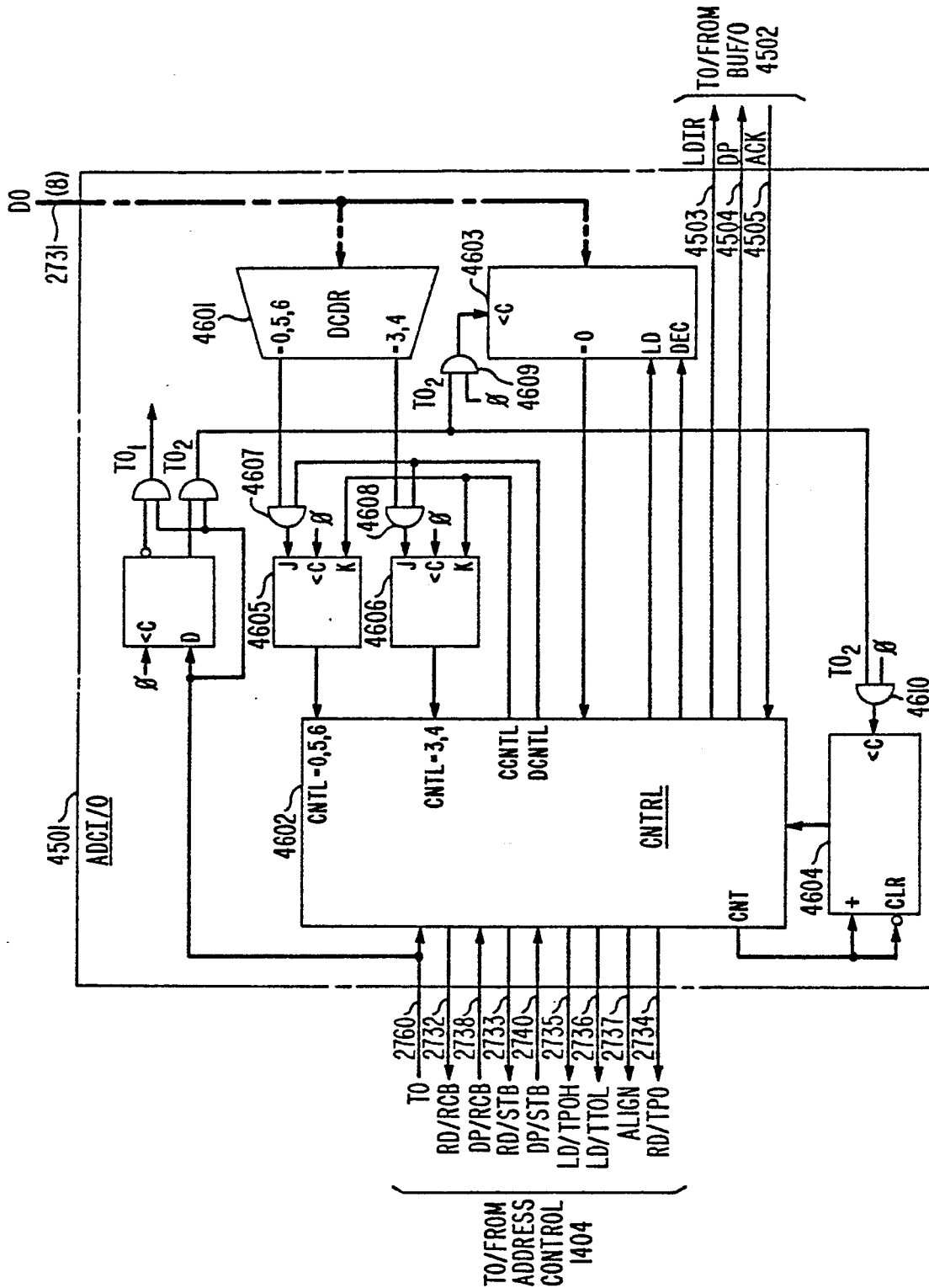

FIG. 46

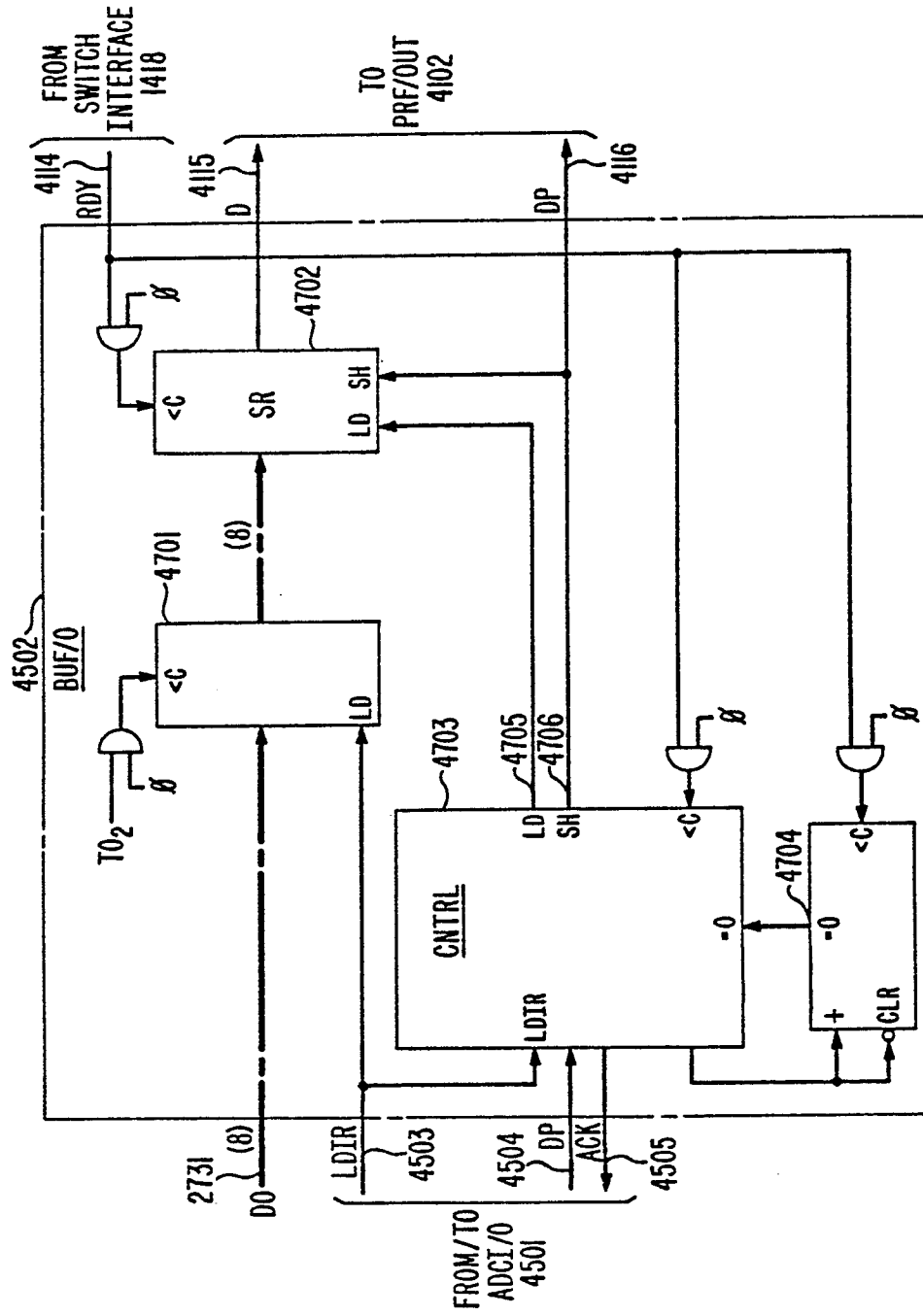

FIG. 47

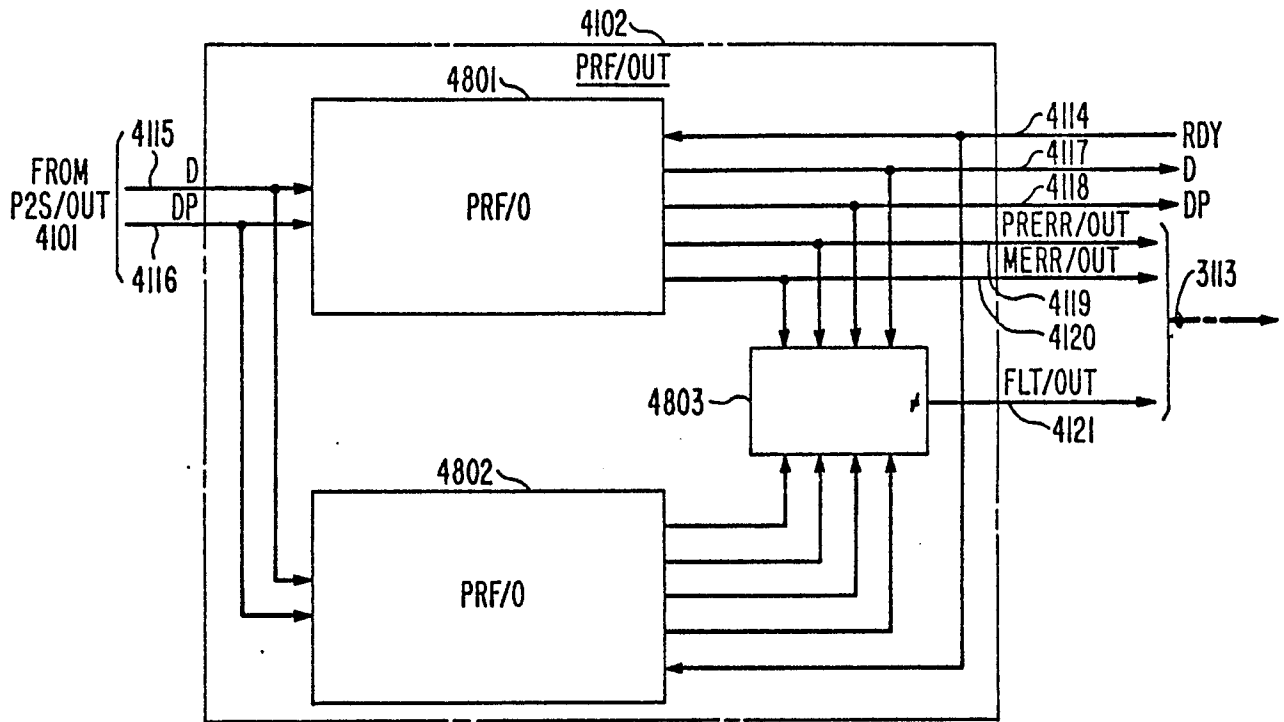

FIG. 48

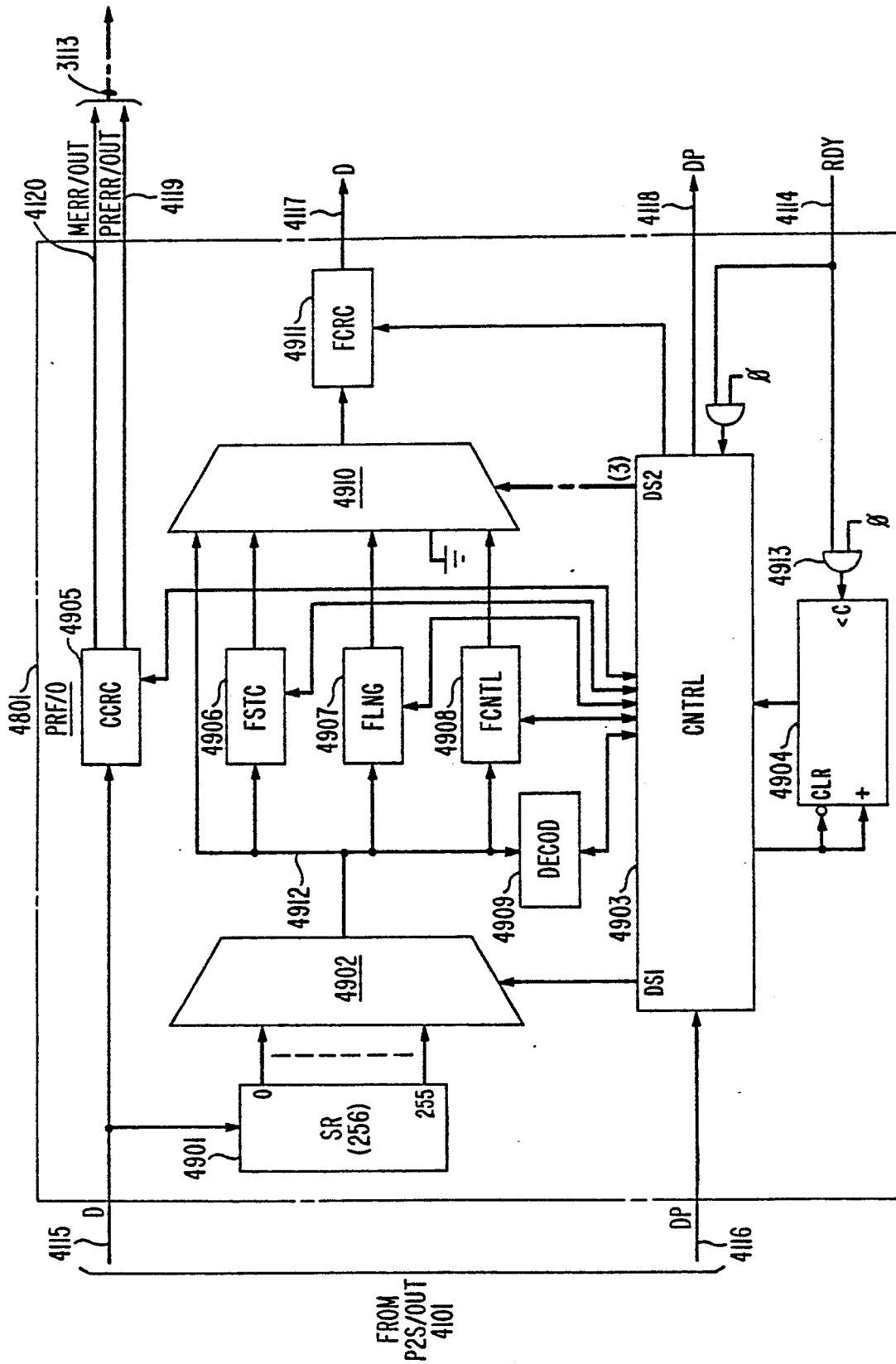

FIG. 49

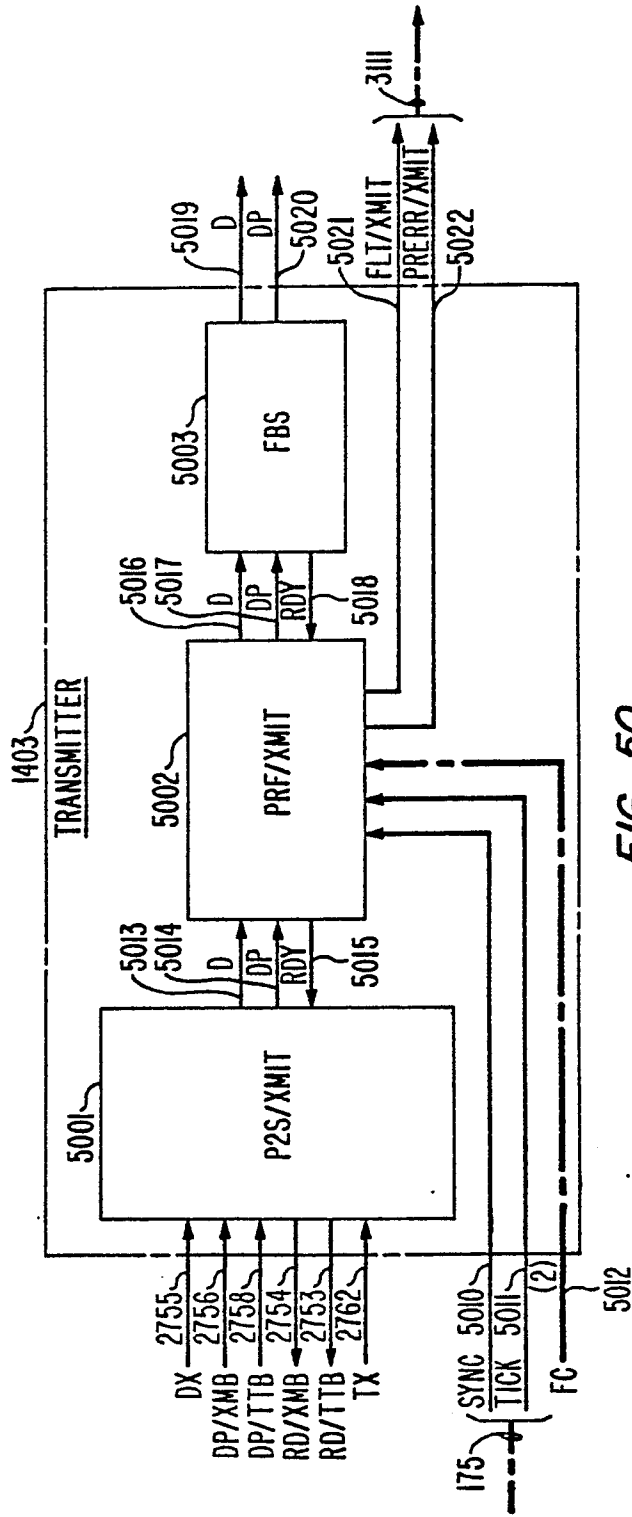

FIG. 50

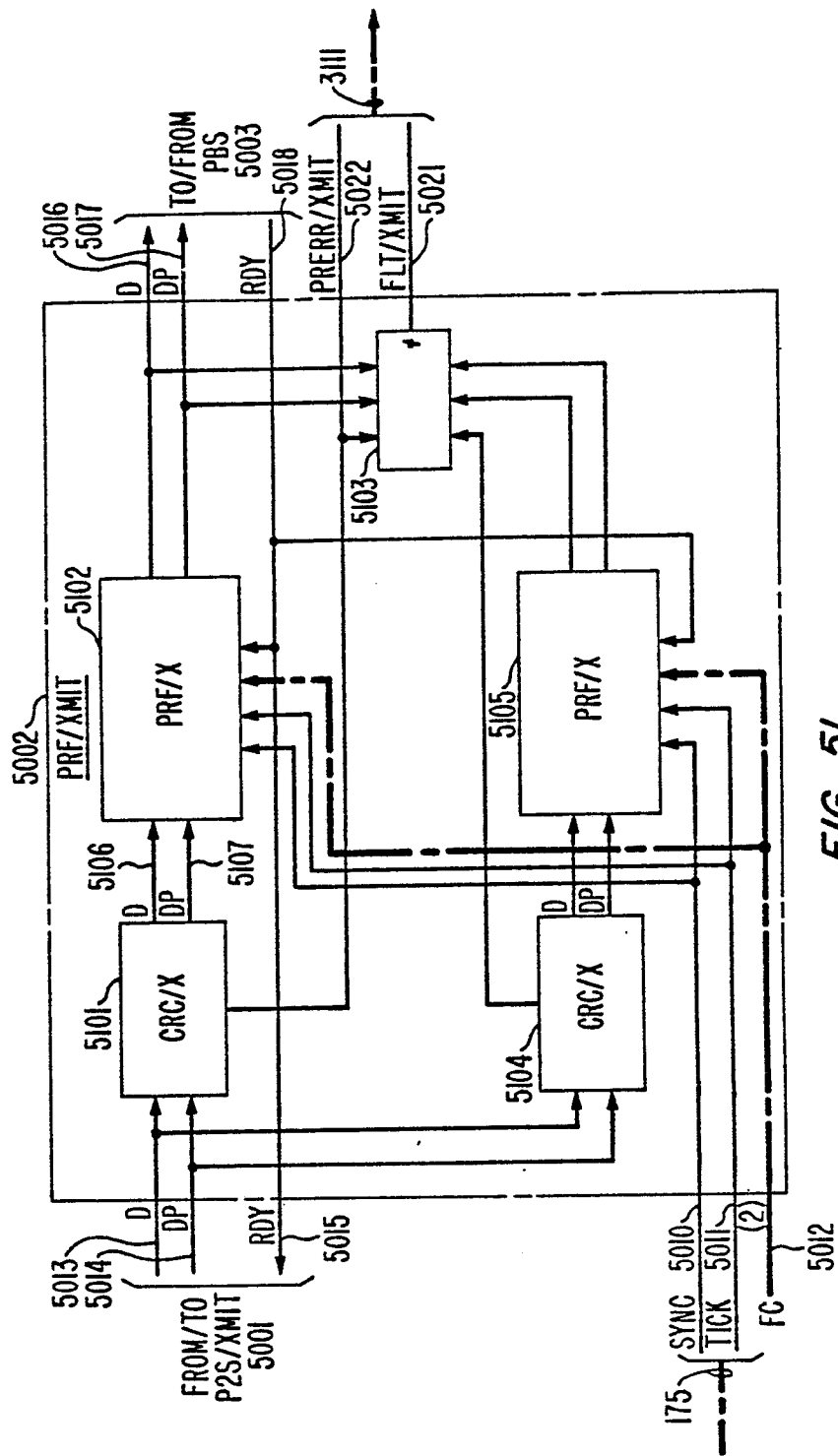

FIG. 51

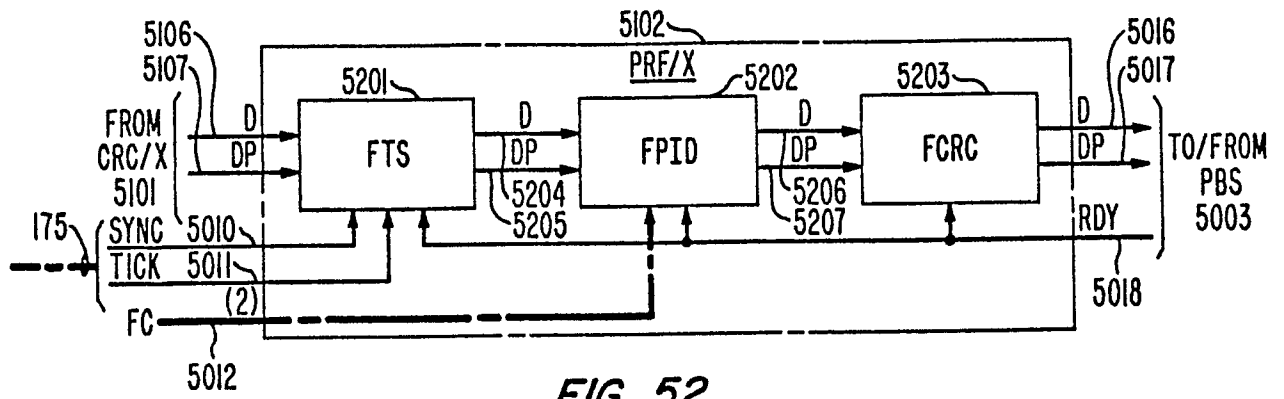

FIG. 52

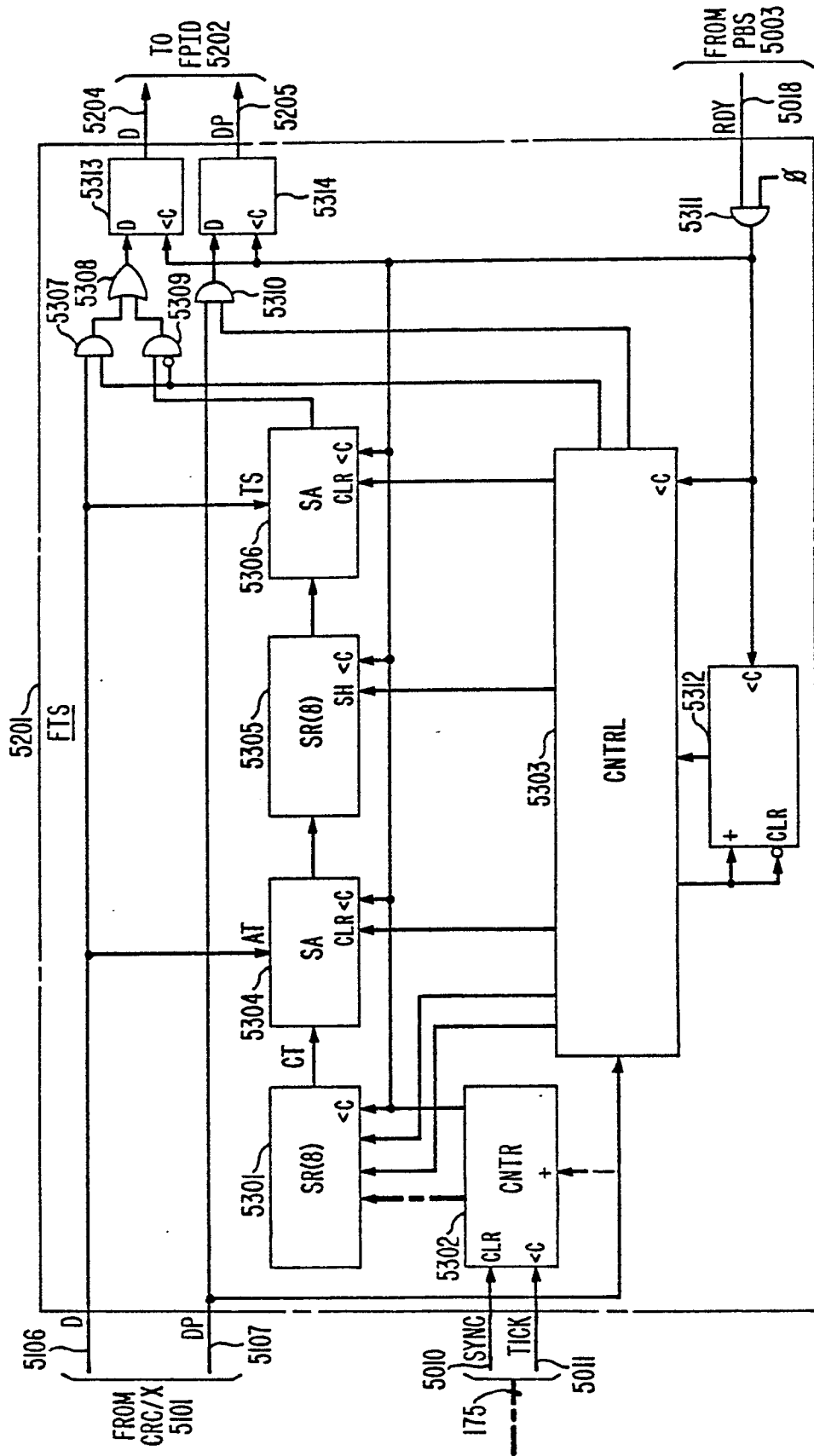
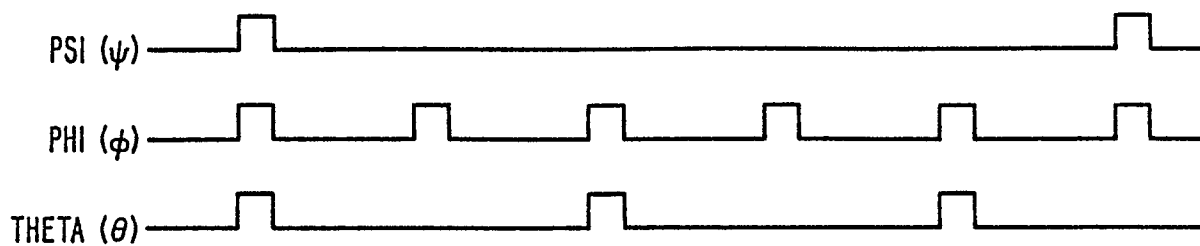

FIG. 53



SYSTEM TIMING DIAGRAM

FIG. 54

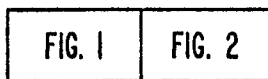

FIG. 55