



Oifig Na
bPaitinní

The
Patents
Office

IE20040175

ABSTRACT

A lamp (1) for illuminating fish farms to promote plant and organism growth, having an elongate watertight housing (2) having first and second ends and a sidewall; a light source (3) within the housing arranged to emit light from the housing; a port (4) in the housing to allow ingress of water when the lamp is submerged in water; and a heat-dissipating element (5) having an elongate heat dissipating body extending into the housing to dissipate heat generated by the light source. The heat dissipating body (5) has an internally located conduit (11) which is in fluid communication with the port (4) in a watertight arrangement so that when the lamp (1) is submerged, water comes in through the port (4) flows internally into the heat dissipating body via the conduit (11) so that the heat dissipating element (5) is cooled by internally circulating water. Halogen bulbs (3) can be used. <Figure 1>

Title

An Underwater Lamp.

5 Field of the Invention

The present invention relates to the field of underwater lighting technology. In particular the invention relates to a lighting device or lamp. Particularly of interest are underwater lamps suitable for the end-use application of fish farming or any application requiring
10 such a device.

Background to the Invention

Artificial lighting is used in fish farming. It promotes the growth of photosynthetic plants
15 and organisms such as algae on which fish feed and are thus employed in fish farms for the purpose of promoting growth of photosynthetic plants and organisms for feeding fish.

To date lamps for underwater use in the fish farming area have experienced a high failure rate and require a good deal of maintenance. Certain current commercially available
20 underwater lamps used for fish farming are based on metal halide technology such as a 400W bulb held in a glass capsule. Those lamps require a "strike voltage pulse" to ignite them. The strike voltage pulse is a term used to refer to the requirement for a sudden surge in voltage (usually of the order of 4.5KV) to initially ignite the bulbs. In general metal halide bulbs do not come to full brilliance immediately.

25

A typical prior art lamp construction is illustrated in Figure 2. for use in underwater applications. Figure 2 illustrates the underwater lamp currently found on the market. A lamp is provided wherein the lamp is a glass enclosure 1 housing a bulb. More specifically the bulbs used are metal halide bulbs 2. Said bulbs 2 require a large start up
30 voltage to ignite them and therefore are only capable of operating at the larger voltage value of 220V. The voltages quoted may be assumed to be AC voltages. As a result of the

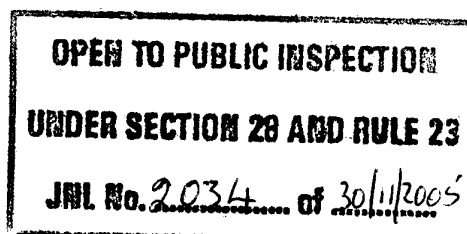
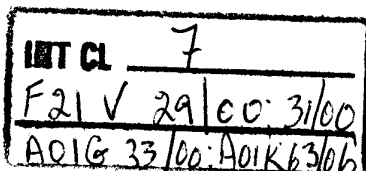

requirement for a large start up voltage a choke capacitor and igniter is required. Both are housed in the “gear box” 3. In order for a sufficiently large voltage to be reached the bulbs the “gear box” 3 must be positioned within 25 metres of the lamp. The lamp further comprises a lead weight to maintain the lamp in a vertical position 4.

5

It should also be noted that any significant decrease in the voltage applied to a metal halide lamp will cause the bulb to stop emitting light and the light from the lamp will be lost. Due to the initial surge voltage requirements it may take 5-8 minutes to ignite the metal halide lamp again and restore the emitted light.

10

The voltage pulse tends to deteriorate the conductive cables etc. of the lamp thus subjecting the lighting equipment to undesirable wear and tear. This in turn shortens the lifespan of the equipment. This lighting equipment also tends to be expensive.

15

More specifically, the insulating material about the conductive wires within the cable tends to break down after a relatively short period of time. Typical cables employed are 1000V 1.5 mm three core cables wherein the 1.5 mm is the cross sectional area of the copper conductor.

20

In addition, in order to create this strike voltage pulse, the system requires a choke capacitor and igniter. Because of the inherent voltage drop along the transmission cable, it is not generally possible to locate the capacitor and igniter at a distance along the cable of more than 25 metres from the lamp, using existing technology. This generally means that a “gear box” holding the capacitor and igniter is placed close to the fish farming area

25

in general proximate to or on a fish cage in which the fish are held.

30

Furthermore the current metal halide lamps require an operational voltage of 220V AC, which means they are incompatible with mains voltages employed in certain countries, for example, in the US the preferred nominal voltage is set at 120V and allows a range of 114 - 126V. The nominal European voltage is now 230V however the use of 220V lamps on sites which are handled by employees are not normally permitted for safety reasons.

Use of lamps at voltages below and up to 110V are permitted on site as these voltages meet with safety requirements.

5 Generally, for safety reasons, it is desirable also to operate lamps in a fish farm at lower voltages. There is thus a requirement for lamps which operate on voltages less than 220V. For example a fish farm may require lamps which operate on 110V or less to meet safety requirements.

10 It is not a simple task however to step down the voltage to a lower level. The reason for operation at 220V is due to the strike voltage pulse requirement of metal halide bulbs. Without reaching that critical voltage the lamps may not ignite at all. The equipment required to operate a 110V lamp, or a lamp at a lower voltage, would be too bulky and expensive, that is if such a lamp existed.

15 A further problem with underwater lamps in general is that the heat produced causes a build-up of heat inside the lamp casing. As a result of this, the heat generated by the bulb(s) inside the lamp casing makes it extremely difficult to effectively seal the casing because of thermal expansion effects, which in turn may lead to small or larger amounts of water entering the lamp casing and damaging the bulbs.

20

US Patent No. 4,683,523 entitled "Deep Submersible Light Assembly" discloses an elongate metal cylindrical body attached to a socket. This lamp houses a quartz-halogen bulb and a focusing arrangement to focus the light in one general direction through a transparent lens cover. The lamp has a cylindrical heat sink screwed to the casing. It also
25 has apertures in the transparent cover to allow ingress of water for pressure equalization purposes. Furthermore, a wattage of 1000W cannot be achieved by this lamp.

US Patent No. 4,219,871 entitled "High Intensity Navigation Light" discloses a light
30 fixture capable of submersion to substantial depths. The bulb used in a tungsten halogen bulb housed in a glass globe and sealed to a heat-dissipating base. The heat-dissipating elements comprise internal and external fins. The internal fins collect heat from internally

heated air while the external fins dissipate heat to surrounding air or water. Furthermore, a wattage of 1000W cannot be achieved by this lamp.

5 An alternative construction of submergible lamp is required which has an effective heat-dissipating means. In particular there is need for a lamp arrangement that dissipate the relatively high heat generated by halogen bulbs effectively. Furthermore, a need for submersible lamps generating a large operational wattage is required.

Object of the Invention

10

It is an object of the present invention to provide an underwater light to overcome the above-mentioned problems of heat dissipation, surge voltage requirements and operational distance restriction which are imposed by cable voltage drop considerations.

15 It is a further objective of the present invention to provide an underwater lamp for use at operational voltages anywhere between 12V and 220V/110V ac or dc. Suitably the lamp should allow for the use of halogen bulbs (for example halogen tubes).

Summary of the Invention

20

According to the present invention there is provided a lamp comprising a watertight housing having first and second ends and at least one sidewall. There is further provided at least one light source within the housing, arranged to emit light from the housing. Furthermore, the watertight housing comprises a port which allows the ingress of water
25 when the lamp is submerged. Additionally, a heat-dissipating element having an elongate heat dissipating body extends into the housing. The function of the heat-dissipating element is to dissipate heat generated by the light source. The heat dissipating body has defined therein an internally located conduit. This internally located conduit is in fluid communication with the port in a watertight arrangement so that when the lamp is
30 submerged water ingressing through the port flows internally into the heat dissipating

body via the conduit so that the heat dissipating element is cooled by internally circulating water.

In one particular embodiment the heat-dissipating element terminates within the housing.
5 The lamp comprises a heat dissipating body having defined therein an internally located conduit. This internally located conduit is in fluid communication with the port. The top closure of the lamp housing has a port that enables circulation of water into and out of the heat sink. In this embodiment the conduit terminates in a blind end. The conduit may possess an open top end and a sealed base. In this particular embodiment the heat-
10 dissipating element is in fluid communication with only one port. The water enters the conduit via the port. For optimum dissipation of heat the heat-dissipating element is centered in said housing, but can be otherwise arranged.

Furthermore, the conduit of the heat-dissipating element may be in fluid communication
15 with at least two ports in the housing so that water may enter or exit the heat-dissipating element through either port.

The heat-dissipating element may comprise an elongate hollow metal tube in fluid communication with at least one port in the housing. By means of both radiative and
20 conductive transfer, the tube absorbs the heat generated by the bulbs. The tube may be of any suitable metal (including alloys) such as copper. Conductive transfer occurs as the bulbs are connected to the tube using heat conductive connectors. All absorbed heat is conducted through the pipe and transferred into the cooling water, assuming the lamp is submerged. The water may enter and exit the copper pipe through the port within the
25 closure, thus creating the convection current which is necessary to sustain the cooling process.

In another embodiment the lamp comprises a watertight housing having first and second ends and at least one sidewall wherein the at least one sidewall is an endless sidewall.
30 The preferred shape of the elongate watertight housing is a cylinder for uniform radiation of light in all directions. At least a portion of the sidewall of the watertight housing is

constructed of transparent material. For optimum radiation all of the sidewalls should be transparent.

5 The lamp housing may comprise a unitary body which has a first open end and a closure for the open end. Alternatively, the lamp housing may comprise a unitary body which has first and second open ends and a closure for each open end.

10 In either embodiment of the lamp, the port maybe provided in a or each closure. The port may be positioned in a closure at the base of the housing or may be positioned in a closure found at the top end of the housing or indeed may be positioned in both.

15 The closure may also carry at least one electrical connector for connecting an electrical cable from an external power source to the light source. The closure is removable from the housing to allow access to the light source within said housing. This permits the owner to access the inner housing for maintenance purposes. The closure at the base of the elongate watertight housing comprises a mounting base. The mounting base enables the lamp to stand upright. The mounting base comprises an internal and external faces on which the lamp can stand.

20 The light source is mounted proximate to the heat-dissipating element. The light source is connected to the heat-dissipating element by means of a heat conductive connector. The heat conductive connector may be a metal connector.

25 In another embodiment the lamp comprises at least one halogen bulb. The preferred arrangement for the halogen bulbs is hanging in a vertical sequence from the upper closure housing the port and electrical cables down to the base of the housing comprising the mounting base. More specifically the halogen bulbs/tubes used in the present invention are 2x300W or 2x500W Halogen tubes are used which are capable of operating at either 220V or 110V. However, the Halogen tubes used in the present invention are not
30 limited to 2x300W or 2x500W. The resulting output when using 2x500W bulbs is 1000W. A drop in voltage has no effect on this type of bulb and the distance of the

electrical supply cables may be greatly extended. The light is not limited to the use of a cable of a maximum length of 25m. It is due to the use of these halogen bulbs and the massive heat generated by them it is necessary to provide a more efficient heat-dissipating technique.

5

In order to assist retaining the lamp in a vertical position a ballast weight may be contained inside the watertight housing. The ballast weight may be mounted on an internal face of the mounting base. It is desirable that the lamp housing be vertically aligned to ensure optimum radiation of light and an effective flow of water within the heat-dissipating element. To achieve this, a balancing weight is suitably positioned on the mounting base of the lamp housing.

10

There are many advantages of the present invention. The underwater light of the present invention arrangement does not require a large surge in voltage in order to ignite the light source and therefore the distance of the cable may be extended beyond the 25 meters used in current underwater lamps for fish farms. More specifically the halogen bulbs/tubes used in the present invention are capable of operating at either 220V or 110V. Another advantage to the present invention is that the light source comes to full brilliance immediately and can be switched on or off as desired.

15

20

In one particular embodiment the heat-dissipating element takes the form of a hollow metal tube terminating at one end. The internal conduit of the hollow metal tube may terminate within the housing in this particular embodiment. After a short period of time following submersion, the water surrounding the lamp flows into the lamp to fill the hollow metal tube. The temperature of the water within the hollow metal tube rises with heat from the light source. The temperature of the water in the pipe increases and the heat from the heat-dissipating element is transferred to the (cold) water within the tube. This heated water in the tube undergoes convection and flows out of the hollow metal tube. Colder water surrounding the lamp is drawn into the hollow metal tube thus creating a convection current. Since the lamp housing is a small volume compared to the volume of

25

30

the surrounding water e.g. seawater, the seawater acts as a large heat sink thus maintaining the lamp at safe operating temperatures.

5 The heat generated by the halogen tubes will be removed by means of a novel type of heat dissipating process as outlined in the appended claims. It is believed that the present invention overcomes the problem of unwanted heat generation in the lamp with the introduction of a water assisted heat-dissipating element. The present invention also provides a lamp with increased light radiation properties.

10 **Brief Description of the Drawings**

These and other features of the present invention will be better understood with reference to the following drawings in which:

15 Figure 1 illustrates the lamp construction of the present invention.

Figure 2 illustrates a typical prior art lamp construction.

Detailed description of the Drawings

20

Referring to the drawings and specifically to Figure 1 there is provided a lamp 1 comprising a watertight housing 2 which may be elongated having first and second ends and at least one sidewall. There exists at least one light source 3 positioned within the housing 2, arranged to emit light from the housing 2. The housing 2 comprises a port 4 to
25 allow ingress of water when the lamp 1 is submerged. The heat-dissipating element 5 has an elongate heat dissipating body extending into the housing 2 dissipates the heat generated by the light source 3. The heat-dissipating body has defined therein an internally located conduit. The conduit is in fluid communication with the port in a watertight arrangement so that when the lamp is submerged, water ingressing through the
30 port 4 flows internally into the heat dissipating body via the conduit so that the heat-dissipating element 5 is cooled by internally circulating water.

Figure 1 further shows a lamp 1 wherein the heat-dissipating element 5 terminates within the housing 2. The heat-dissipating element 5 terminates within the housing 2 in this particular embodiment but is not limited thereto. In this particular embodiment the
5 conduit terminates in a blind end.

The conduit of the heat-dissipating element 5 may be in fluid communication with at least two separate ports 4 (not shown) in the housing so that water may enter or exit the heat-dissipating element 5 through either port 4.

10

Water can flow into and out of the same port 4. In this particular arrangement the coldwater flows into the heat-dissipating element 5. By means of both radiative and conductive transfer, the heat-dissipating element 5 absorbs the heat generated by the bulbs 3. Conductive transfer occurs as the bulbs 3 are connected directly to the heat-dissipating 5 element using metal contacts 6. All absorbed heat is conducted through the
15 heat-dissipating element and transferred into the cold water, assuming the lamp 1 is submerged. The heated water then rises to the top of the heat-dissipating element 5 and flows out of the port 4.

20 Furthermore, the lamp in Figure 1 illustrates the heat-dissipating element 5 being centered in said housing 2. This allows for maximum dissipation of heat. The heat-dissipating element 5 comprises an elongate hollow metal tube in fluid communication with at least one port 4 in the housing.

25 The construction of the lamp 1 is such that at least one sidewall is an endless sidewall. The lamp 1 is preferably is constructed such that at least one sidewall of the elongated watertight housing 2 is constructed of transparent material. This allows for optimum radiation of light.

30 A lamp 1 wherein the housing 2 comprises a unitary body which has a first open end and a closure for said open end. Alternatively, the lamp housing 2 may comprises a unitary

body which has first and second open ends and a closure for each open end. A lamp 1 wherein the port 4 is provided in a closure.

The closure carries at least one electrical connector 7 for connecting an electrical cable
5 from an external power source to the light source 3.

The closure may be removable from the housing 2 to allow access to the light source 3 within said housing 2. Additionally the closure at the base of the watertight housing comprises a mounting base 8. The lamp 1 wherein the mounting base 8 comprises
10 internal and external faces on which the lamp 1 can stand.

The light source 3 is mounted proximate to the heat-dissipating element 5. A lamp 1 wherein the light source 3 is connected to the heat-dissipating element by means of a heat conductive connector 6. The heat conductive connector 6 may take the form of a metal
15 connector 6. Within the preferred embodiment the light source 3 comprises at least one halogen bulb.

Furthermore the watertight housing 2 is sealed to a mounting base 8. In order for the lamp 1 to remain vertically positioned a ballast weight 9 is required. It is favorable to maintain
20 the lamp 1 in a vertical position so as to permit maximum light radiation in all possible directions. The ballast weight 9 is contained within the watertight housing 2 and is mounted on the internal face of the mounting base 8.

It will be appreciated that when the lamp is in operation and the light source is ignited,
25 the heat generated by light source is transferred to the heat-dissipating element or heat sink. The heat transfer occurs by both radiative and conductive means. When the lamp is submerged in water (For example seawater) the heat-dissipating element is at a higher temperature than the surrounding water.

30 Having described in detail a preferred embodiment of our deep submersible light assembly, it will be understood by those skilled in the art that our invention may be

modified in both arrangement and detail. Therefore the protection afforded our invention should only be limited in accordance with the scope of the following claims.

5 The words "comprises/comprising" and the words "having/including" when used herein with reference to the present invention are used to specify the presence of stated features, integers, steps or components but does not preclude the presence or addition of one or more other features, integers, steps, components or groups thereof.

10 It is appreciated that certain features of the invention, which are, for clarity, described in the context of separate embodiments, may also be provided in combination in a single embodiment. Conversely, various features of the invention which are, for brevity, described in the context of a single embodiment, may also be provided separately or in any suitable subcombination.

15 The invention is not limited to the embodiments hereinbefore described but may be varied in both construction and detail.

20

25

30

Claims

1. A lamp comprising:
 - (i) an elongate watertight housing having first and second ends and at
5 least one sidewall;
 - (ii) at least one light source within the housing and arranged to emit
light from the housing;
 - (iii) a port in the housing to allow ingress of water when the lamp is
submerged in water;
 - 10 (iv) a heat-dissipating element having an elongate heat dissipating body
extending into the housing to dissipate heat generated by the light source, the body
having defined therein an internally located conduit which is in fluid communication with
the port in a watertight arrangement so that when the lamp is submerged, water ingressing
through the port flows internally into the heat dissipating body via the conduit so that the
15 heat dissipating element is cooled by internally circulating water.
2. A lamp as claimed in claim 1 wherein the heat-dissipating element
terminates within the housing.
- 20 3. A lamp as claimed in claim 2 wherein the conduit terminates in a blind
end.
4. A lamp as claimed in claim 1 wherein the conduit of the heat-dissipating
element is in fluid communication with at least two ports in the housing so that water
25 may enter or exit the heat-dissipating element through either port.
5. A lamp as claimed in any preceding claim wherein the heat-dissipating
element is centered in said housing.

6. A lamp as claimed in any preceding claim wherein said heat-dissipating element comprises an elongate hollow metal tube in fluid communication with at least one port in the housing.

5 7. A lamp as claimed in any preceding claim wherein the at least one sidewall is an endless sidewall.

8. A lamp as claimed in any preceding claim wherein the at least one sidewall of the elongated watertight housing is constructed of transparent material.

10

9. A lamp according to any preceding claim wherein the housing comprises:
(a) a unitary body which has a first open end; and
(b) a closure for the open end.

15 10. A lamp according to any preceding claim wherein the housing comprises:
(c) a unitary body which has first and second open ends; and
(d) a closure for each open end.

20 11. A lamp according to claim 9 or claim 10 wherein the port is provided in a or each closure.

12. A lamp as claimed in claim 9 or claim 10 wherein a or each closure carries at least one electrical connector for connecting an electrical cable from an external power source to the light source.

25

13. A lamp as claimed in any of claims 9 to 12 wherein a or each closure is removable from the housing to allow access to the light source within said housing.

30 14. A lamp as claimed in any preceding claim wherein the closure at the base of the elongate watertight housing comprises a mounting base.

15. A lamp as claimed in claim 14 wherein said mounting base has internal and external sides and the lamp can stand on the external side.

5 16. A lamp as claimed in any preceding claim wherein the light source is mounted proximate to the heat-dissipating element.

17. A lamp as claimed in claim 16 wherein the light source is connected to the heat-dissipating element by means of a heat conductive connector.

10 18. A lamp as claimed in claim 16 or claim 17 wherein the heat conductive connector is a metal connector.

15 19. A lamp as claimed in any preceding claim wherein the light source comprises at least one halogen bulb.

20. A lamp as claimed in any preceding claim wherein a ballast weight is contained inside the watertight housing.

20 21. A lamp as claimed in claim 20 wherein the ballast weight is arranged on or in the mounting base.

TOMKINS & CO.

25

30 spec1343

1/1

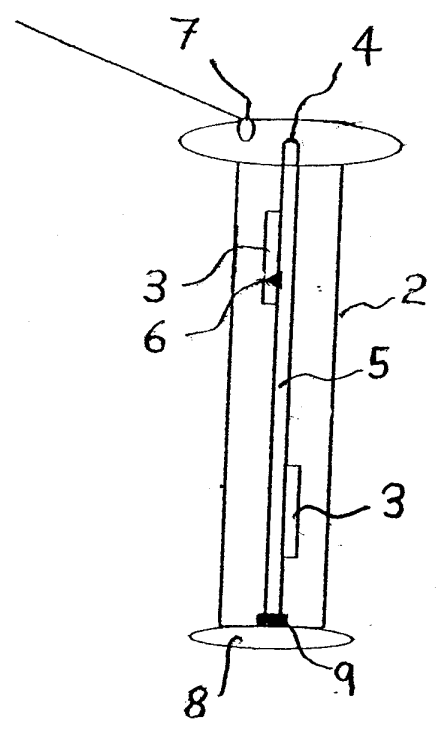

Fig 1

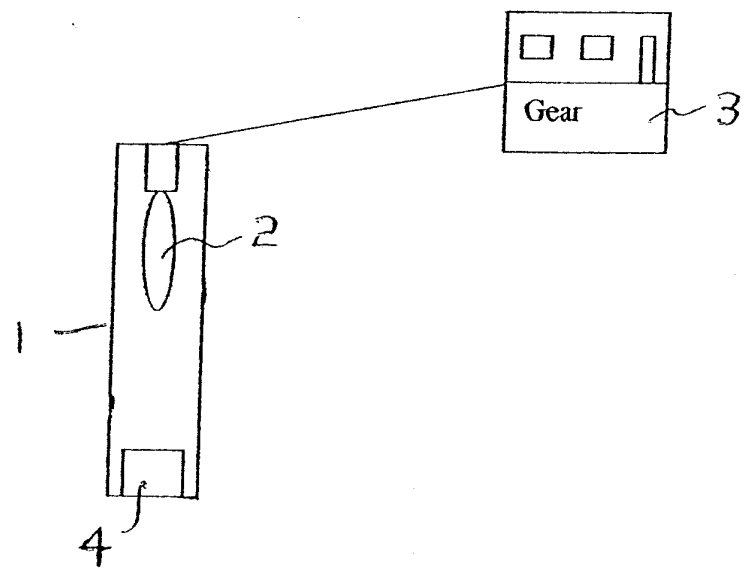

Fig 2 - (PRIOR ART)