

(12) STANDARD PATENT
(19) AUSTRALIAN PATENT OFFICE

(11) Application No. **AU 2001230027 B2**

(54) Title
A drinking and pouring device for a can

(51)⁷ International Patent Classification(s)
B65D 043/10 B65D 047/06

(21) Application No: **2001230027** (22) Date of Filing: **2001.02.01**

(87) WIPO No: **WO02/44048**

(30) Priority Data

(31) Number	(32) Date	(33) Country
PA200001812	2000.12.01	DK

(43) Publication Date: **2002.06.11**

(43) Publication Journal Date: **2002.08.15**

(44) Accepted Journal Date: **2005.01.06**

(71) Applicant(s)
Bent Olsen

(72) Inventor(s)
Olsen, Bent Hjort

(74) Agent / Attorney
PIZZEYS, GPO Box 1374, BRISBANE, QLD, 4001

(56) Related Art
US 6073797
US 4403709
US 5088614

(12) INTERNATIONAL APPLICATION PUBLISHED UNDER THE PATENT COOPERATION TREATY (PCT)

(19) World Intellectual Property Organization
International Bureau



(43) International Publication Date
6 June 2002 (06.06.2002)

PCT

(10) International Publication Number
WO 02/44048 A1

- (51) International Patent Classification?: B65D 43/10, 47/06
- (21) International Application Number: PCT/DK01/00074
- (22) International Filing Date: 1 February 2001 (01.02.2001)
- (25) Filing Language: English
- (26) Publication Language: English
- (30) Priority Data:
PA 2000 01812 1 December 2000 (01.12.2000) DK
- (71) Applicant and
(72) Inventor: OLSEN, Bent, Hjort [DK/DK]; Roskildevej 133, DK-3400 Hillerød (DK).
- (74) Agent: PATENTGRUPPEN APS; Arosgården, Aaboulvarden 23, DK-8000 Aarhus C (DK).
- (81) Designated States (national): AE, AG, AL, AM, AT, AT (utility model), AU, AZ, BA, BB, BG, BR, BY, BZ, CA, CH, CN, CR, CU, CZ, CZ (utility model), DE, DE (utility model), DK, DK (utility model), DM, DZ, EE, EE (utility model), ES, FI, FI (utility model), GB, GD, GE, GH, GM, HR, HU, ID, IL, IN, IS, JP, KE, KG, KP, KR, KZ, LC, LK, LR, LS, LT, LU, LV, MA, MD, MG, MK, MN, MW, MX, MZ, NO, NZ, PL, PT, RO, RU, SD, SE, SG, SI, SK, SK (utility model), SL, TJ, TM, TR, TT, TZ, UA, UG, US, UZ, VN, YU, ZA, ZW.
- (84) Designated States (regional): ARIPO patent (GH, GM, KE, LS, MW, MZ, SD, SL, SZ, TZ, UG, ZW), Eurasian patent (AM, AZ, BY, KG, KZ, MD, RU, TJ, TM), European patent (AT, BE, CH, CY, DE, DK, ES, FI, FR, GB, GR, IE, IT, LU, MC, NL, PT, SE, TR), OAPI patent (BF, BJ, CF, CG, CI, CM, GA, GN, GW, ML, MR, NE, SN, TD, TG).

[Continued on next page]

(54) Title: A DRINKING AND POURING DEVICE FOR A CAN

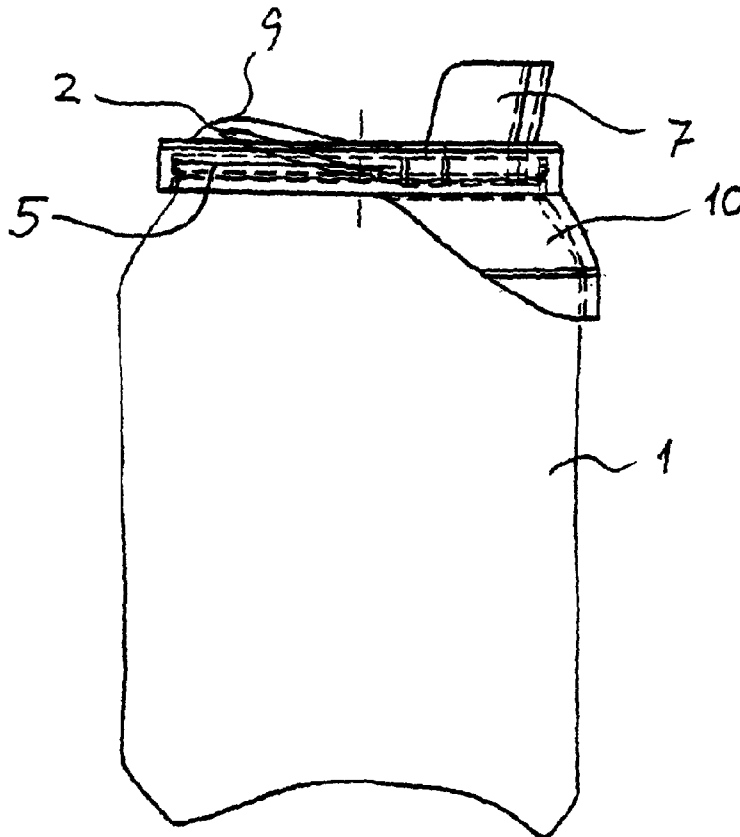

(57) Abstract: The invention describes a drinking and pouring device for a beverage can (1) with opening means including a tear-up closure in the top surface (5) including a tearing ring (2) and an opening in the top surface (5), wherein the device comprises a cover (3) with a rim flange (4) substantially circumscribing the upper perimeter of the top surface (5) of the can (1) for snap-on mounting of the device onto the can (1), a hole (6) in the cover (3), a spout (7) covering a section of the hole (6), and a sealing flange (8) enclosing the tearing ring (2) of the opening means on the can (1). By the present invention, a simple cap or lid for a can is provided, wherein the volume of the gap may be reduced or event eliminated so that the risk of releasing dirt particles or other impurities from the surface of the can is reduced which results in a hygienic pouring and drinking device.



WO 02/44048 A1

WO 02/44048 A1



Published:

— *with international search report*

For two-letter codes and other abbreviations, refer to the "Guidance Notes on Codes and Abbreviations" appearing at the beginning of each regular issue of the PCT Gazette.

A DRINKING AND POURING DEVICE FOR A CAN

The present invention relates to a drinking and pouring device for a beverage can with opening means including a tear-up closure in the top surface including a tearing
5 ring and an opening in the top surface.

Sprouts or similar devices for mounting on top of beverage cans are known for use in connection with drinking the content of the can from e. g. US-A-4,387,826 and US A-
10 5,062,552.

These known devices constitute some sort of cap or lid that is mounted on top of the can to block the top opening of the can after it has been opened. The devices are designed in such a way that it is possible to drink the content through a pouring attachment that may be opened and closed.

15 The problem with such known devices is that a portion of the liquid from the can flows into the enclosed gap between the lid and the top surface of the can when the beverage liquid is poured out of the can. In a similar fashion, an amount of beverage liquid remains in the gap between the lid and the top of the can after a portion of the
20 beverage has been poured. This means that impurities from the surface around the can opening are washed out with the drinking liquid just as the impurities are flushed back into the can. This means that there is a risk that the beverage may be contaminated.

25 Another problem with drinking the content of the can is that a person may cut him or herself on the sharp edges in the region around the opening.

On this basis, it would clearly be advantageous to provide a device, which would reduce the hygiene problem associated with known spouts for cans, such as beer
30 cans, fresh beverage cans and the like.

According to a first aspect of the present invention there is provided a device for a can, wherein the device comprises a cover with an annular rim flange substantially circumscribing the upper perimeter of the top surface of the can for snap-on mounting of the device onto the can, a hole in the cover, a spout covering a section of the hole, and a sealing flange enclosing the tearing ring of the opening means on the can.

The present invention provides, a simple cap or lid for a can, wherein the volume of the gap may be reduced or even eliminated so that the risk of releasing dirt particles or other impurities from the surface of the can is reduced which results in a hygienic pouring and drinking device. When the device is positioned on top of the can, the sealing flange makes contact with the top surface of the can, thus reducing the gap volume of the flow passage for the liquid. Due to the cover and the annular snap-on rim flange, the risk of being cut on the edges is eliminated, as the entire top surface of the can is covered by a the device according to the invention.

In order to ensure a tight fitting onto the top, an upwardly protruding dimple enclosing the tearing ring may be provided. Hereby, it is ensured that the device provides a liquid tight seal even if the tearing ring of the opening means on the can is not fully bent over.

In the preferred embodiment, the spout partly encompasses a section of the outside of hole along an outer section of the hole. Hereby, the device is particularly suitable as a pouring device since the spout is semicircular in its cross-section. This makes it possible for air to enter into the can whilst pouring the liquid out of the can and at the same time avoid liquid slashing out of the can which allows for a continuous and gentle flow of liquid out of the can.

In an embodiment of the invention, a protective flange extension is provided on the rim flange directly next to the spout. Hereby, the device covers the part of the can with which the mouth or chin would otherwise make contact when drinking directly

from the can. Moreover, the flange extension may be used for assisting in the opening of the tear-up closure of the can.

In the preferred embodiment, the device is made in one single piece, preferably moulded in a biologically inert polymer material. Hereby, the hygienic aspect is taken a step further, as it is ensured that no fluid may be trapped in sharp corners in the device whilst either drinking or cleaning the device or during engagement with the material of the device. When producing the device in a single moulded piece, the device is provided with smooth transitions between the various portions.

10

In a preferred embodiment of the invention, the rim flange may slide on the periphery of the top surface for shifting the hole away from the opening of the can by turning the device. Hereby, a closure function is provided in addition to the other advantages in a simple but efficient way. In order for the closure function to work properly, the spring force created by the rim flange when snapped onto the top surface in its position allows this sliding movement. Since the tearing ring is usually able to be turned on the opening means of the can, this ring will rotate together with the device on the top surface of the can.

20 The invention is explained in detail with reference to the embodiments described in the accompanying drawings, in which

fig. 1 is a side view of a device according to a first embodiment of the invention,

25 fig. 2 to 4 are rear, bottom and top views, respectively, of same,

fig. 5 is a schematic side view of a device mounted onto a can, and

fig. 6 is a side view of a second embodiment of the invention.

In figures 1 to 5, a first embodiment of a device according to the invention for pouring and drinking the content of a beverage can is shown. The device comprises a cover 3 with an annular flange 4 dimensioned in such a manner that it can be

30

mounted onto the top of a can. The flange 4 ensures that the device is mounted by snap-on mounting. The device is provided with a hole 6 placeable directly above the opening in the top surface 5 of the can 1 (see figs. 1 and 5). A spout 7 is provided around a section of the hole 6. The device is formed so that the periphery of the hole 6 is in contact with the top surface 5 of the can 1 or at least around the section of the hole 6 provided with an upwardly protruding spout 7. Hereby, the liquid content of the can may be poured out of the can and into a glass or may be drunk directly from the can 1. In the cover flange opposite the hole 6, an upwardly protruding dimple 9 is formed so that the tearing ring 2 of the opening means of the can is enclosed. On the inside or lower side of the cover 3, a sealing flange 8 is provided around the periphery of the dimple 9 enclosing the tearing ring 2 and ensuring that the gap between the lower side of the cover 3 and the top surface 5 is limited, so that the flow communication between the opening and the peripheral regions on the top surface is blocked. This is important, since deposits of dirt and other impurities are often collected in these regions.

By the sealing flange 7, these deposits are prevented from being brought into contact with the beverage and thus from being washed out into the glass or the like.

The cover 3 may be provided with a hollow annular periphery 11 inside the rim flange 2. Hereby, drops of beverage running on the outside of the spout may be collected so that the can will not leave ring marks on e.g. the table where it is being placed after the content has been emptied out.

In the first embodiment, an extension flange 10 is provided on the rim flange 4 outside the spout 7. This extension ensures a comfortable drinking experience when drinking directly from the can 1, since the lips of the mouth are prevented from coming in contact with the can itself.

This extension flange 10 may be provided with an inscription, such as an advertisement, a logo, a personalised mark, a name, etc.

In a second embodiment, the device may be provided with a broad rim flange 4 as shown in fig. 4. Otherwise, the device may be provided with the same features as described in the first embodiment, i.e. the sealing flange 8, the spout 7, the hole 6, etc. The broad rim flange 4 may provide a better grip on the can.

The spout 7 is preferably and substantially semicircular shape so that a passage exists for letting air into the can whilst pouring the liquid out of the can. Hereby, slashing is avoided.

10

By the invention, it is understood that many variations of the drinking and pouring device may be made without departing from the scope of the inventions such as described in the accompanying claims.

THE CLAIMS DEFINING THE INVENTION ARE AS FOLLOWS:

1. A drinking and pouring device for a beverage can with opening means including a tear-up closure in the top surface including a tearing ring and an opening
5 in the top surface,
said device comprising a cover with a rim flange substantially circumscribing the upper perimeter of the top surface of the can for snap-on mounting of the device onto the can, a hole in the cover,
characterised in that
10 the device includes a spout covering a section of the hole, and a sealing flange enclosing the tearing ring of the opening means on the can, and wherein the rim flange may slide on the periphery of the top surface for shifting the hole away from the opening of the can by turning the device.
- 15 2. A drinking and pouring device according to claim 1, wherein an upwardly protruding dimple for enclosing the tearing ring is provided.
3. A drinking and pouring device according to claim 1 or 2, wherein the spout encloses a section of the outside of hole along an outer section of the hole.
20
4. A drinking and pouring device according to any of the preceding claims, wherein a protective flange extension is provided on the rim flange directly next to the spout.
- 25 5. A drinking and pouring device according to any of the preceding claims, wherein the device is made in one single piece.
6. A drinking and pouring device according to any of the preceding claims, wherein the device is moulded in a biologically inert polymer material.
30

7. A drinking and pouring device for a beverage can substantially as herein described in any one of the embodiments in the detailed description of the invention with reference to the drawings.

5 DATED THIS TWELFTH DAY OF MAY, 2003.

BENT HJORT OLSEN

BY

PIZZEYS PATENT & TRADE MARK ATTORNEYS

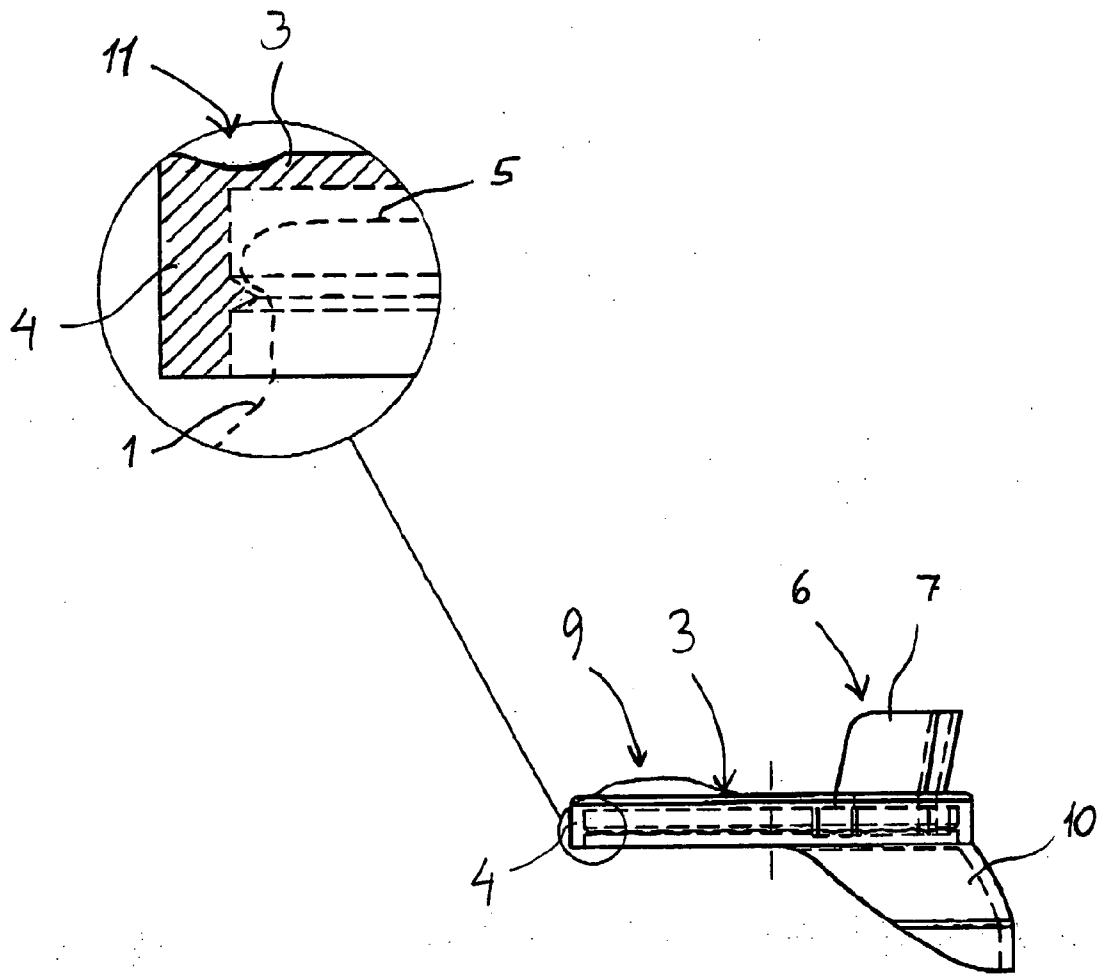
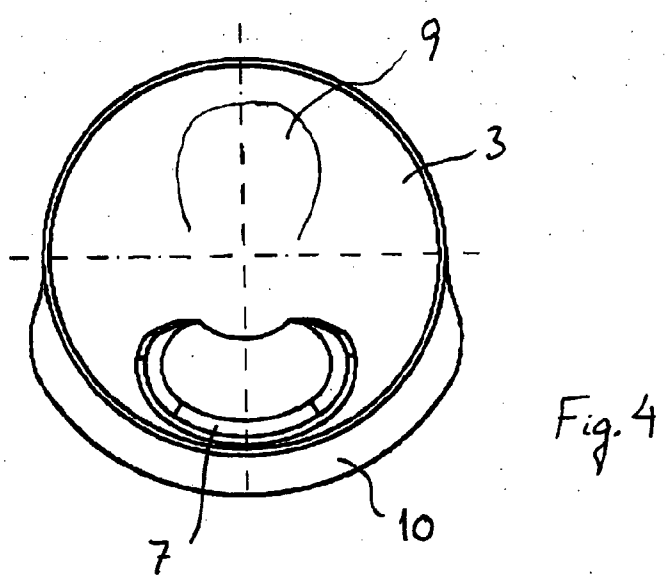
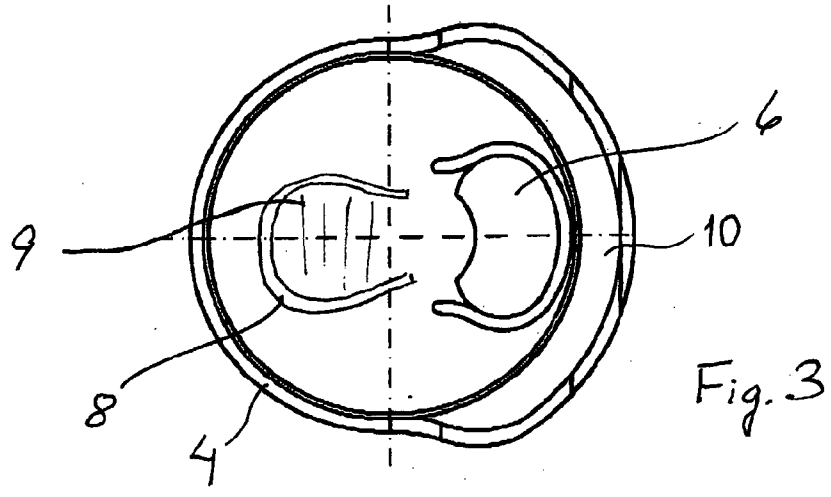
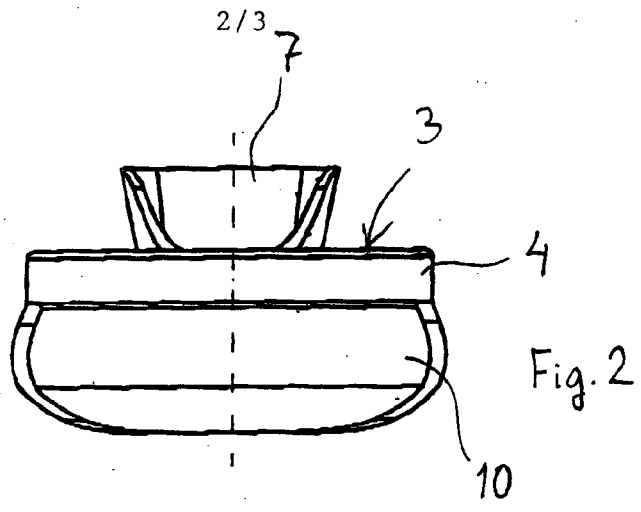

Fig. 1



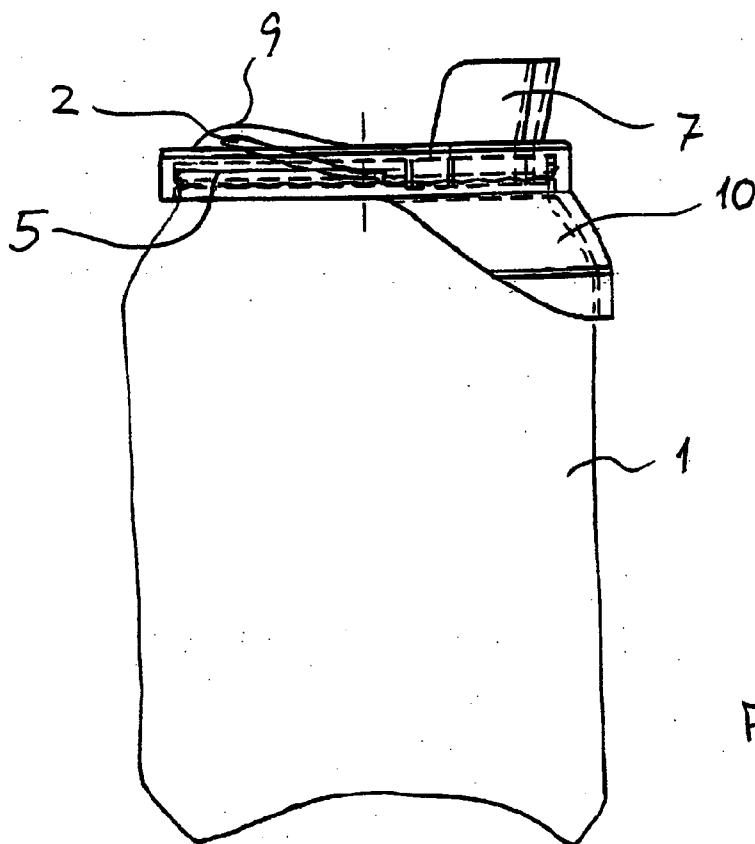

Fig. 5

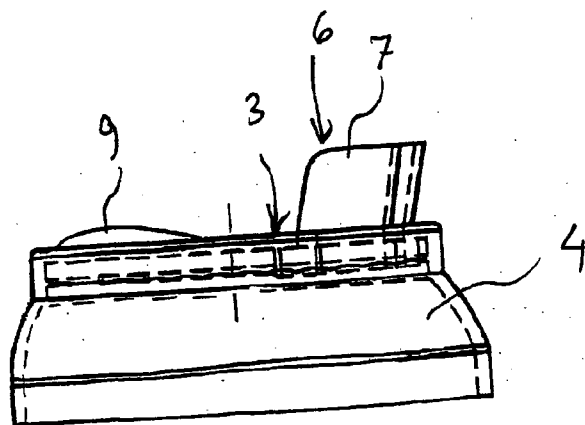

Fig. 6