



(12) **DEMANDE DE BREVET CANADIEN
CANADIAN PATENT APPLICATION**

(13) **A1**

(86) **Date de dépôt PCT/PCT Filing Date:** 2021/12/09
 (87) **Date publication PCT/PCT Publication Date:** 2022/06/16
 (85) **Entrée phase nationale/National Entry:** 2023/06/06
 (86) **N° demande PCT/PCT Application No.:** US 2021/062675
 (87) **N° publication PCT/PCT Publication No.:** 2022/125816
 (30) **Priorités/Priorities:** 2020/12/09 (US63/123,266);
 2021/12/09 (US17/546,963)

(51) **Cl.Int./Int.Cl. F01K 25/10** (2006.01),
F01K 19/04 (2006.01), **F01K 7/16** (2006.01)
 (71) **Demandeur/Applicant:**
 SUPERCRITICAL STORAGE COMPANY, INC., US
 (72) **Inventeur/Inventor:**
 HELD, TIMOTHY, US
 (74) **Agent:** ROBIC

(54) **Titre : SYSTEME DE STOCKAGE D'ENERGIE THERMIQUE ELECTRIQUE A TROIS RESERVOIRS**
 (54) **Title: THREE RESERVOIR ELECTRIC THERMAL ENERGY STORAGE SYSTEM**

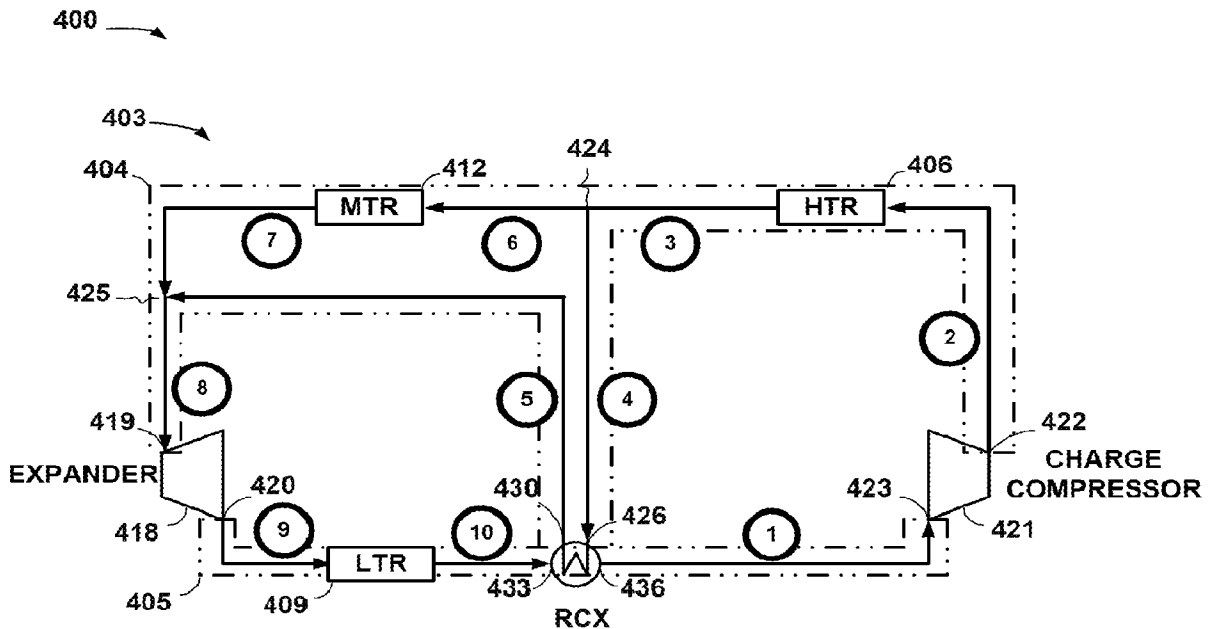

FIG. 4A

(57) **Abrégé/Abstract:**

A method for operating a pumped thermal energy storage (PTES) system includes circulating a working fluid through a working fluid circuit, the working fluid having a mass flow rate and a specific heat capacity and balancing a product of the mass and the specific heat capacity of the working fluid on a high-pressure side of a recuperator and a low side of the recuperator as the working fluid circulates through the working fluid circuit. The PTES system includes a bypass in the working fluid circuit by which a first portion of the working fluid bypasses the high-pressure side of the recuperator while a second portion of the working fluid circulates through the high-pressure side of the recuperator.

Date Submitted: 2023/06/06

CA App. No.: 3201373

Abstract:

A method for operating a pumped thermal energy storage (PTES) system includes circulating a working fluid through a working fluid circuit, the working fluid having a mass flow rate and a specific heat capacity and balancing a product of the mass and the specific heat capacity of the working fluid on a high-pressure side of a recuperator and a low side of the recuperator as the working fluid circulates through the working fluid circuit. The PTES system includes a bypass in the working fluid circuit by which a first portion of the working fluid bypasses the high-pressure side of the recuperator while a second portion of the working fluid circulates through the high-pressure side of the recuperator.

THREE RESERVOIR ELECTRIC THERMAL ENERGY STORAGE SYSTEM

THREE RESERVOIR ELECTRIC THERMAL ENERGY STORAGE SYSTEM

CROSS-REFERENCE TO RELATED APPLICATIONS

[001] This application claims priority to co-pending U.S. Prov. Appl. No. 63/123,266, entitled "3-Reservoir ETES System", filed December 9, 2020, in the name of Timothy Held and U.S. Non-Provisional Patent Application No. 17/546,963 filed on December 9, 2021. This application is incorporated herein by reference in its entirety for all purposes, including the right of priority, as if set forth *verbatim* herein.

TECHNICAL FIELD

[002] This present disclosure is directed to an electric thermal energy storage ("ETES") system and, more particularly, to a carbon dioxide ("CO₂")-based pumped thermal energy storage ("PTES") system.

BACKGROUND

[003] PTES systems, sometimes also known as electro-thermal energy storage systems, are used to store and re-generate energy. PTES systems generally use a configurable thermodynamic cycle where thermal energy is transferred between a high-temperature reservoir and a low-temperature reservoir via working fluid in a working fluid circuit. In its simplest version, a PTES consists of a thermodynamic cycle that operates as a heat pump in one direction of thermal and fluid flow, and operates as a heat engine in the opposite direction of thermal and fluid flow, where thermal energy is transferred between two reservoirs, one at high temperature and the other at low temperature as shown in FIG. 1A. The operation of a PTES can be broadly described as including a "charging" phase and a "generating" phase.

[004] During the “charging” phase of operation, thermal energy is upgraded from a low-temperature reservoir (“LTR”) to a high-temperature reservoir (“HTR”) by using the heat pump cycle in the nominally forward direction. During this process, an electrical motor is used to drive a gas compressor, which increases the working fluid pressure and temperature. The thermal energy contained in the working fluid is transferred to the high-temperature reservoir (“HTR”) by using an indirect heat exchanger. Further thermal energy is transferred from the working fluid downstream of the indirect heat exchanger to the fluid upstream of the gas compressor in a recuperator heat exchanger. The fluid is then expanded through a turbine, which produces shaft work that is used to help drive the compressor. The working fluid at the turbine exit is lower pressure, and much lower temperature. Heat is transferred from the low-temperature reservoir (“LTR”) to the working fluid, which brings it back to the initial state at the compressor inlet.

[005] During the “generating” phase of operation, the directions of fluid and heat flows are reversed. The fluid exiting the LTR is compressed, but now the “compressor” inlet and outlet temperatures are much lower—in fact, for the carbon dioxide (CO₂)-based version of the system, the fluid may be at the liquid state, and thus the “compressor” is actually a pump. The fluid is then heated to a relatively high-temperature by the HTR, and expanded through a turbine, producing shaft work. This turbine work now exceeds the compressor work, and the excess is converted to electrical power by a generator and fed back into the electrical grid. Residual thermal energy at the turbine discharge is transferred to the working fluid upstream of the HTR in the recuperator heat exchanger.

SUMMARY

[006] The technique disclosed herein reduces the impact of the heat capacity mismatch across a recuperator and thereby avoid the lost exergy associated with a temperature-heat transferred (“TQ”) slope mismatch described below. The presently disclosed technique also markedly improves cycle performance. As used herein, “exergy” is the maximum useful work possible during a process that brings the system into equilibrium with a heat reservoir.

[007] The presently disclosed technique includes a method and an apparatus. A method for operating a pumped thermal energy storage (“PTES”) system includes circulating a working fluid through a working fluid circuit, the working fluid having a mass flow rate and a specific heat capacity and balancing a product of the mass and the specific heat capacity of the working fluid on a high-pressure side of a recuperator and a low side of the recuperator as the working fluid circulates through the working fluid circuit. The PTES system includes a bypass in the working fluid circuit by which a first portion of the working fluid bypasses the high-pressure side of the recuperator while a second portion of the working fluid circulates through the high-pressure side of the recuperator.

BRIEF DESCRIPTION OF THE DRAWINGS

[008] The present disclosure is best understood from the following detailed description when read with the accompanying Figures. It is emphasized that, in accordance with the standard practice in the industry, various features are not drawn to scale. In fact, the dimensions of the various features may be arbitrarily increased or reduced for clarity of discussion.

[009] FIG. 1A is a process flow diagram for a prior art PTES system during a charging phase of a PTES operational cycle.

[010] FIG. 1B is a process flow diagram for a prior art PTES system during a generating phase of a PTES operational cycle.

[011] FIG. 2 is a pressure-enthalpy diagram for baseline PTES cycle including numbers in boxes that are state points for the generating phase for the prior PTES system of FIG. 1A-FIG. 1B.

[012] FIG. 3 is a temperature-heat transferred (“TQ”) plot for the baseline PTES cycle of FIG. 2 in the PTES system of FIG. 1A-FIG. 1B.

[013] FIG. 4A is a process flow diagram for a PTES system during a charging phase of a PTES operational cycle in accordance with one or more embodiments.

[014] FIG. 4B is a process flow diagram for a PTES system during a generating phase of a PTES operational cycle in accordance with one or more embodiments.

[015] FIG. 5 illustrates one particular example of a control system by which the working fluid circuit of FIG. 4A-FIG. 4B may be configured for the charging phase, shown in FIG. 4A, and the generating phase, shown in FIG. 4B.

[016] FIG. 6A-FIG. 6F illustrate several implementations of the thermal reservoirs of FIG. 4A-FIG. 4B as may be found in various embodiments.

DETAILED DESCRIPTION

[017] One metric of overall cycle performance is the “round-trip efficiency” (“RTE”). This parameter defines the amount of electrical energy (kWh) that can be produced during the generating phase divided by the amount of electrical energy that was consumed during the charging phase. The other key performance parameter is system capital cost, which can be defined in terms of generating capacity or in terms of storage capacity.

[018] FIG. 1A and FIG. 1B illustrate a prior art PTES system 100 with a PTES operating cycle whose pressure-enthalpy diagram is shown in FIG. 2. Working fluid states indicated in FIG. 2 in boxes are indicated in FIG. 1A-FIG. 1B in circles. Thus, the operating states at various points in the operational cycle of the PTES system 100 can be mapped from the pressure-enthalpy diagram of FIG. 2 to the process flow diagrams of FIG. 1A-FIG. 1B. FIG. 1A illustrates a charging phase of the operating cycle while FIG. 1B illustrates a generating phase of the operating cycle. In the following discussions and the accompanying drawings, the nomenclature set forth in Table 1 shall be used.

Table 1. Nomenclature

Acronym	Meaning
ACC	Air-cooled cooler
HTR	High-temperature reservoir
HTX	High-temperature reservoir to CO ₂ heat exchanger
LPT	Low-pressure turbine
LTR	Low-temperature reservoir

LTX	Low-temperature reservoir to CO ₂ heat exchanger
MTR	Medium-temperature reservoir
MTX	Medium-temperature reservoir to CO ₂ heat exchanger
PFD	Process flow diagram
PTES	Pumped thermal energy storage
RCX	Recuperator heat exchanger
RTE	Round-trip efficiency

[019] The PTES system 100 includes a working fluid circuit 103, a HTR 106, a LTR 109 and a recuperator RCX. The configuration of the working fluid circuit 103 depends, in part, on whether the PTES system 100 is in the charging phase or the generating phase of the operational cycle. As those in the art having the benefit of this disclosure will appreciate, the configuration is generally a function of programmed control of fluid flow valves. Thus, in the charging phase some components of the working fluid circuit 103 are switched in and some are switched out by controlling the flow of the working fluid through the working fluid circuit 103. Similarly, in the generating phase, other components may be switched in and other components out, again by controlling the flow of the working fluid through the working fluid circuit 103. The fluid flow valves and controller(s) therefore are omitted in FIG. 1A-FIG. 1B for the sake of clarity.

[020] In the charging phase, as shown in FIG. 1A, the working fluid circuit 103 includes an expander 115, a charge compressor 112, and an air-cooled cooler ACC1 between the recuperator RCX and the expander 115. The expander 115 is used for expansion processes in which the working fluid is expanded. The charge compressor 112 is used for compression processes in which the working fluid is compressed. In the generating phase, shown in FIG. 1B, the working fluid circuit 103 includes a pump 118 for compression processes. Similarly, the working fluid circuit 103 includes a power turbine 121 in the generating phase. Furthermore, the working fluid circuit 103 omits the air-cooled cooler ACC1 from the charging phase and in the generating phase includes an air-cooled cooler ACC2. The air-cooled cooler ACC2 is positioned between the LTR 109 and the recuperator RCX.

[021] In the presently used nomenclature, “high-temperature” and “low-temperature” are relative to one another—that is, the HTR operates at temperatures higher than the

temperatures at which the LTR operates. The terms “hot” and “cold” are used relative to one another. For instance, the HTR 106 may operate at temperatures ranging from 100 to 340°C and the LTR 109 may operate at temperatures ranging from -2 to 2°C depending on the embodiment.

[022] In the charging phase, shown in FIG. 1A, heat transfers from the LTR 109 to the working fluid and heat transfers from the working fluid to the HTR 106, respectively. In the generating phase, shown in FIG. 1B, heat transfer occurs in the opposite direction. Heat transfers from the working fluid to the LTR 109 and heat transfers to the working fluid from the HTR 106, respectively.

[023] Unlike a traditional heat engine, in a theoretical ideal cycle with 100% efficient turbomachinery, no pressure losses, and perfectly matched temperatures through the heat exchangers, the RTE of the PTES process is 100%. In practice, thermodynamic irreversibilities, pressure losses and finite temperature approaches through the heat exchangers result in lower RTE values. For the charging phase of the baseline cycle depicted in FIG. 1A, using carbon dioxide (“CO₂”) and a reasonable set of efficiency values, *etc.*, one can calculate an RTE of 50-55%.

[024] Thermodynamic irreversibilities, for example, can introduce inefficiency. Thermodynamically ideal compression and expansion processes are described as “adiabatic, isentropic” devices. In FIG. 2, the expansion and compression processes are represented by the diagonal lines—for example, from State 4 to 5 in the generating phase. The term “isentropic” refers to a constant entropy process. In the non-ideal case shown, the compression process is non-isentropic, thus showing a shallower slope when increasing pressure than does the corresponding generation expansion process. Due to these irreversibilities, the compression process consumes more work than the expansion process returns.

[025] Inefficiency is also incurred in circulating the working fluid. The pressure losses during the heat addition and rejection processes (*e.g.*, State 7 to State 1 in the generating process) represent work lost in circulating fluid through the heat exchangers and piping. Thus, the basic act of circulating the working fluid itself causes inefficiencies.

[026] Furthermore, finite temperature differences between the working fluid and the thermal storage media are required to drive heat transfer between the two materials. Because the direction of heat transfer reverses between the charging phase and the generating phase, and because the reservoir material temperatures are fixed, the working fluid temperatures during charging need to be higher than the HTR and lower than the HTR, while during generating they need to be lower than the HTR and higher than the HTR. These temperature differentials represent lost thermodynamic potential, which reduce the round-trip efficiency of the system.

[027] Still further, the PTES system 100 utilizes internal heat transfer, also known as "recuperation". This process is represented in the PTES system 100 by the recuperator RCX. Recuperation is used to elevate the temperature of the working fluid entering the compressor 112 during the charge cycle while also lowering the temperature of the working fluid entering the power turbine 115. Conversely, during the generation cycle, the PTES system 100 uses recuperation to preheat the working fluid before entering the HTR 106 by extracting residual heat from the turbine 121 exhaust.

[028] The heat transfer between the working fluid and the LTR 109 and the working fluid and the HTR 106 occurs through a heat exchanger of the respective thermal reservoir. The heat exchanger is not shown for the sake of clarity. The heat transfer process through a heat exchanger can be illustrated in a temperature-heat transferred plot, also known as a "TQ plot".

[029] FIG. 3 is a temperature-heat transferred ("TQ") plot for the baseline PTES cycle of FIG. 2 in the PTES system 100 of FIG. 1A-FIG. 1B. The TQ plot of FIG. 3 shows how the fluid temperature decreases/increases as heat is transferred when the working fluid pressure is high (curve 402) and when the working fluid pressure is low (curve 404). The slope of the TQ curves can be shown to be proportional to the inverse of the product of the fluid mass flow rate and specific heat capacity. The working fluid for the PTES system 100 in FIG. 1A-FIG. 1B is CO₂.

[030] In the baseline version of the cycle, the working fluid flow rate through both sides of the recuperator RCX is the same. In the thermodynamically ideal case, the specific heat capacity of the working fluid would be the same on both sides of the recuperator

RCX. In that situation, the two TQ curves 402, 404 would be parallel. As the heat exchanger conductance (“UA”) increased, the two curves would approach each other, and at the limit of infinite UA, would overlay each other.

[031] However, some working fluids, including CO₂, have specific heat capacity properties that vary with pressure as well as temperature. Since the two sides of the heat exchanger are at different pressures, the TQ curves are no longer parallel, but exhibit a “pinch” behavior at one of the heat exchanger “ends”. Even though the amount of heat lost by the hot stream is the same as the amount gained by the cold stream, the temperature of the hot stream exiting the heat exchanger is higher than the temperature of hot stream entering. This temperature differential represents a lost “thermodynamic potential value” and reduces system performance (a more rigorous analysis can be performed using thermodynamic exergy destruction calculation methods to arrive at the same conclusion). In this case, the excess temperature of the fluid leaving the high-pressure end of the recuperator requires external heat rejection to the environment to achieve a nearly fully liquid state at the expander outlet. This heat lost has a direct impact on cycle performance.

[032] As mentioned above, the presently disclosed technique reduces the impact of specific heat capacity mismatch across the recuperator to avoid the lost exergy associated with the TQ slope mismatch and thereby improve cycle performance markedly. In order to match the TQ curve slopes, the mass flow rate of the high-heat capacity fluid is reduced such that the product (“ mc_p ”) of the mass (“ m ”) and the specific heat capacity (“ c_p ”) is the same on both sides of the recuperator. In the supercritical carbon dioxide (“sCO₂”) power cycle known as the re-compression Brayton cycle (“RCB cycle”), this is accomplished by intentionally bypassing part of the CO₂ flow around the high-pressure side of the low-temperature recuperator using a second “bypass” compressor. However, because the PTES cycle operates at considerably lower temperatures than does the RCB cycle, this option is not available as it would require compression from a two-phase flow inlet.

[033] Instead, during the charging phase, the presently disclosed technique adds a flow path parallel to the high-pressure side of the recuperator. Approximately 40% of the high-

pressure CO₂ flow bypasses the high-pressure side of the recuperator and transfers its heat to a third heat transfer medium (the “medium-temperature reservoir”, or “MTR”). The remaining approximately 60% of the flow proceeds through the recuperator. Now, the product of the mass and the specific heat capacity of both sides of the recuperator is nearly identical, thus permitting a much closer approach temperature between the fluids. The two flows are then recombined prior to passing through the expander. The heat extracted from the first 40% of the high-pressure CO₂ is transferred to a thermal storage medium.

[034] During the generation cycle, the process is reversed. Approximately 60% of the CO₂ flow is split from the pump discharge and its temperature increased by transferring heat from the MTR medium. The remainder of the CO₂ passes through the high-pressure side of the recuperator, transferring heat from the recuperator. The flows recombine prior to being further heated by the high-temperature reservoir material.

[035] The reduced exergy destruction results in substantial improvement in system performance. With comparable high-temperature and low-temperature reservoirs and other pressure, temperature and heat exchanger area constraints, the new cycle results in eight points higher round-trip efficiency (“RTE”), increasing from approximately 52% to 60%. It also enables the elimination of the charging phase ACC.

[036] Turning again to the drawings, FIG. 4A-FIG. 4B illustrate a charging phase and a generating phase, respectively, of an operational cycle for a PTES system 400 in accordance with one or more embodiments of the presently disclosed technique. Referring collectively to FIG. 4A and FIG. 4B, the PTES system 400 includes a configurable working fluid circuit 403, a high-temperature reservoir (“HTR”) 406, a low-temperature reservoir (“LTR”) 409, and a medium-temperature reservoir (“MTR”) 412. The PTES system 400 may be characterized as a “three reservoir system” because there are three reservoirs—the HTR 406, the LTR 409, and the MTR 412.

[037] The HTR 406 is so called because it operates at temperatures higher than those at which the LTR 409 and the MTR 412 operate. Similarly, the LTR 409 operates at temperatures lower than those at which the HTR 406 and the MTR 412 operate. The MTR 412 operates at temperatures intermediate those at which the HTR 406 and the LTR 409

operate. Thus, relative to the reservoirs HTR 406, LTR 409, and MTR 412, the terms “high”, “medium”, and “low” describe the relative temperatures at which the three reservoirs HTR 406, LTR 409, and MTR 412 operate.

[038] Each of the thermal reservoirs HTR 406, LTR 409, and MTR 412 include a thermal storage medium not separately shown. In the illustrated embodiment, the thermal storage media are sand, liquid water and a water/ice mixture for the HTR 406, MTR 412, and LTR 409, respectively. However, the thermal storage medium may be any suitable thermal storage medium and alternative embodiments may use alternative thermal storage media. Each of the thermal reservoirs HTR 406, MTR 412, and LTR 409 may include heat exchangers, piping, pumps, valves and other controls not separately shown to transfer heat between the thermal storage media and the working fluid during operation of the PTES system 400.

[039] For example, in the illustrated embodiment of FIG. 4A-FIG. 4B, the HTR 406 may be what is known as a three-tank system such as the three-tank system 600 shown in FIG. 6A. In a 3-tank system, during the charging process, the working fluid enters a first heat exchanger HTX1, where it transfers heat to a thermal reservoir medium. It then enters a second heat exchanger HTX2, where it transfers additional heat to a second thermal reservoir material. The thermal reservoir medium is transported from a first tank HTRc to the second heat exchanger HTX2, where it receives heat from the working fluid. Additional thermal reservoir material is stored in a second tank HTRm at an intermediate temperature is mixed with the thermal reservoir material. The mixed thermal reservoir material is then transported to the first heat exchanger HTX1, where it receives heat from the working fluid and is then stored in a third tank HTRh.

[040] During the generating process, the directions of flow are reversed. Working fluid first enters a second heat exchanger HTX2, where it receives heat from a thermal reservoir medium. The working fluid then enters a first heat exchanger HTX1, where it receives additional heat from the thermal reservoir medium. Thermal reservoir medium is transported from a third tank HTRh to the first heat exchanger HTX1, where it transfers heat to the working fluid. The cooled thermal reservoir medium is then split into a first portion and a second portion. The first portion of thermal reservoir material is stored in a

second tank HTR_m. The second portion of thermal reservoir material is transported to the second heat exchanger HTX₂ where it transfers additional heat to the working fluid. The cooled second portion of thermal reservoir material is stored in a first tank HTR_c.

[041] Similarly, in the illustrated embodiment of FIG. 4A-FIG. 4B, the MTR 412 and the LTR 409 may be implemented in a two-tank system such as the two-tank system 603 shown in FIG. 6B. In a two-tank thermal reservoir, during the charging process, the working fluid enters a heat exchanger and transfers heat to a thermal reservoir medium, which could be a liquid such as oil, water or molten salt, or a flowing granular medium, such as silica sand or sintered bauxite. The thermal reservoir medium is transported from a first tank HTR_c to the heat exchanger where it receives heat from the working fluid, and then is stored in a second tank HTR_h.

[042] During the generating process, the direction of fluid flow is reversed. Working fluid enters a heat exchanger and received heat from a thermal reservoir medium. The thermal reservoir medium is transported from a second tank HTR_h to a heat exchanger, where it transfers heat to the working fluid. The cooled thermal transport medium is then stored in the first tank HTR_c.

[043] Other types of tank systems may be used in alternative embodiments. One such tank system is a solid thermocline reservoir 606, shown in FIG. 6C. In a thermocline thermal reservoir, during the charging process, working fluid enters a relatively lower temperature thermal storage medium. The thermal storage medium is generally a solid-phase material through which the working fluid may flow, either through pores in the thermal storage medium or through embedded tubes or pipes (not shown) within the thermal storage medium material. As the working fluid flows through the thermal storage medium, heat is transferred from the working fluid to the thermal storage medium, raising its temperature. The working fluid is cooled to a lower temperature and exits the thermal reservoir.

[044] During the generating process, the direction of working fluid flow is reversed. Relatively lower temperature working fluid enters the heated thermal storage medium. Heat is transferred from the thermal storage medium, lowering its temperature, to the

working fluid, raising its temperature. The heated working fluid then exits the thermal reservoir.

[045] Another alternative tank system is a thermocline 609 with a thermal transfer fluid (“TTF”) loop, shown in FIG. 6D. Alternatively, during the charging process, the working fluid can transfer heat in a heat exchanger to a fluid thermal transfer medium, such as oil, water or air. The thermal transfer medium can then transfer heat to a thermal storage medium by flowing through the thermal storage medium. The cooled thermal transfer fluid is then transported to the heat exchanger, where it is reheated by the working fluid. During the generating process, the directions of working fluid and thermal transfer fluid are reversed.

[046] There are also one-tank thermocline storage systems such as the one-tank thermocline storage system 612 in FIG. 6E. In a one-tank thermocline reservoir, during the charging process working fluid enters a heat exchanger, where it transfers heat to a thermal transfer fluid. The heated thermal transfer fluid is transported to the top of a tank, where its lower fluid density results in thermal stratification with the higher-temperature fluid remaining in an upper layer. Colder thermal transfer fluid is withdrawn from the bottom of the tank and is transported to the heat exchanger.

[047] During the generating process, the directions of flow are reversed. Relatively higher temperature thermal transfer fluid is transported from the top of the tank to the heat exchanger, where it heats the working fluid. The cooled thermal transfer fluid is transported to the bottom of the tank, where it remains thermally-stratified and separated from the higher temperature thermal transfer fluid.

[048] Embedded heat transfer surface systems such as the system 615 shown in FIG. 6F are also known. In an embedded heat transfer surface thermal reservoir, working fluid is transported through a series of tubes, pipes or other fluid channels that are immersed in a relatively uniform temperature thermal storage medium. In this example, the thermal storage medium can be water or another fluid that is near its freezing point, and the working fluid can be a liquid that is near its boiling point, or a liquid/vapor mixture at its boiling point temperature. During the heat transfer process, heat is transferred from the working fluid to the thermal storage medium, causing the working fluid to boil at constant

temperature, while the thermal storage medium freezes from a liquid to a solid. The working fluid exits the thermal reservoir as a vapor at or slightly in excess of its boiling point

[049] During the generating process, the direction of working fluid flow is reversed. The working fluid enters at a pressure such that the boiling point of the working fluid is slightly above the freezing point of the thermal storage medium. Heat is transferred from the working fluid to the thermal storage medium, condensing the working fluid to a liquid state, and melting the thermal storage medium to a liquid state.

[050] One or more of the tank systems shown in FIG. 6A-FIG. 6E may be used to implement the HTR 406, MTR 412, and LTR 409 in various alternative embodiments depending on implementation specific considerations. However, the list is neither exhaustive nor exclusive. Still other tank system designs may also be used.

[051] Referring again to FIG. 4A-FIG. 4B, also common to the configurable working fluid circuit 403 in the charging phase and the generating phase is a bypass 415. The bypass 415 includes a MTR 412. As mentioned above and as will be discussed further below, the bypass 415 permits a portion of the working fluid to bypass the high-pressure side of the recuperator RCX.

[052] FIG. 4A particularly illustrates the charging phase of the PTES operating cycle. In the charging phase, the configurable working fluid circuit 403 includes an expander 418 and a charge compressor 421. In the illustrated embodiment, the working fluid is CO₂. Alternative embodiments may use alternative working fluids as are known to the art. The following discussion of the charging phase is to be considered in conjunction with operating conditions set forth in Table 2. Those in the art having the benefit of this disclosure will appreciate that the values set forth in Table 2 are, in part, a function of the fact that the working fluid is CO₂. A different implementation of the working fluid may yield different values for the operating conditions in Table 2.

[053] Also, in the following discussion, the state of the working fluid at any given point in the working fluid circuit 403 during the charging phase in FIG. 4A is shown as a numeral in a circle. Thus, the first state, or state 1, is shown as the numeral 1 in a circle in FIG. 4A. This can then be mapped back into Table 2 for a fuller characterization of the state.

Table 2. Charging Phase Operating Conditions

State	Out	In	H (kJ/kg)	P (MPa)	T (°C)	S (kJ/kg/K)	w (kg/sec)
1	RCXI	Compr	568.91	3.20	114.94	2.287	49.53
2	Compr	HTR	791.45	30.00	362.60	2.326	49.53
3	HTR	Split1	428.89	29.80	118.22	1.594	49.53
4	Split1A	RCXh	428.89	29.80	118.22	1.594	28.76
5	RCXh	Mix1A	196.14	29.70	1.16	0.890	28.76
6	Split1B	MTR	428.89	29.80	118.22	1.594	20.77
7	MTR	Mix1B	238.23	29.70	23.45	1.037	20.77
8	Mix1	Exp	213.79	29.70	10.57	0.953	49.53
9	Exp	LTR	189.36	3.40	-4.34	0.961	49.53
10	LTR	RCXI	433.75	3.30	-1.05	1.863	49.53

[054] The disclosure herein references the “high-pressure side” and the “low-pressure side” of the recuperator RCX, or the “RCXh” and the “RCXI”, respectively. In the charging phase illustrated in FIG. 4A, the charge compressor 421 pressurizes the working fluid and provides the motive force for circulating the working fluid in the charging phase. The expander 418 expands, or depressurizes, the working fluid.

[055] The portion of the working fluid circuit 403 through which the working fluid is pressurized by the charge compressor 421 circulates may be referred to as the “high-pressure side” of the working fluid circuit 403. Similarly, the portion of the working fluid circuit 403 through which the working fluid expanded by the expander 418 circulates may be referred to as the “low-pressure side” of the working fluid circuit 403. Thus, the high-pressure side 404 of the working fluid circuit 403 extends from the outlet 422 of the charge compressor 421 to the inlet 419 of the expander 418. The low-pressure side 405 extends from the outlet 420 of the expander 418 to the inlet 423 of the charge compressor 421.

[056] The high-pressure side of the recuperator RCX is the side of the recuperator RCX that interfaces with the high-pressure side 404 of the working fluid circuit 403. In the charging phase shown in FIG. 4A, that would be the side of the recuperator RCX defined by the ports 426, 430 by which the pressurized working fluid circulates through the

recuperator RCX. The low-pressure side of the recuperator RCX is the side that interfaces with the low-pressure side 405 of the working fluid circuit 403. The low-pressure side of the recuperator RCX is defined by the ports 433, 436 by which the expanded working fluid circulates through the recuperator RCX.

[057] During the charging phase, beginning at the recuperator RCX, the working fluid exits the recuperator RCX and enters charge compressor 421 in a first state, or state 1, at a first temperature T_1 and a first pressure P_1 . The charge compressor 421 compresses the working fluid and increases the temperature and pressure of the working fluid. The working fluid then leaves the charge compressor 421 in a second state at a second temperature T_2 and a second pressure P_2 , the second temperature and the second pressure being greater than the first temperature T_1 and the first pressure P_1 , respectively.

[058] The working fluid then enters the high-temperature reservoir HTR 406 in the second state at the second temperature T_2 and the second pressure P_2 . In the HTR 406, heat is transferred from the working fluid to the thermal storage medium in the HTR 406. The heat transfer process reduces the pressure and the temperature of the working fluid to a third state as the working fluid exits the HTR 406 at a third temperature T_3 and a third pressure P_3 .

[059] The working fluid then reaches a point 424 in the working fluid circuit 403 and splits. A first portion of the working fluid enters the bypass 415 and a second portion enters the line 427. The second portion enters the line 427 in a fourth state at a fourth temperature T_4 and a fourth pressure P_4 . Reference to Table 2 shows that the fourth state is at the third temperature and the third pressure—*i.e.*, $T_4=T_3$ and $P_4=P_3$ —but differs from the third state prior to the split. The fourth state differs by having a lower mass flow rate than does the third state although the second portion is at the same temperature and pressure as the working fluid in the third state. The second portion then enters the high-pressure side of the recuperator RCX through the port 426 in the fourth state at the fourth temperature T_4 and the fourth pressure P_4 .

[060] In the recuperator RCX, heat is exchanged between the second portion and the circulating working fluid on the low-pressure side of the recuperator. This heat exchange cools the second portion to a fifth state in which, as shown in Table 2, the second portion

is at a significantly lower fifth temperature T_5 and a slightly lower fifth pressure P_5 . The second portion then exits the recuperator RCX on the high-pressure side of the recuperator RCX through the port 430 in a sixth state at a fifth temperature T_5 and a fifth pressure P_5 .

[061] While the second portion is circulating through recuperator RCX, the first portion enters the bypass 415 in a sixth state. Reference to Table 2 shows that the sixth state differs from the third state prior to the split. The sixth state differs by having a lower mass flow rate than does the third state although the second portion is at the same temperature and pressure as the working fluid in the fourth state. The first portion then enters the MTR 412 in the sixth state at a sixth temperature T_6 and a sixth pressure P_6 .

[062] In the MTR 412, heat is transferred between the medium-temperature thermal reservoir MTR 412 and the first portion of the working fluid. Recall that the MTR 412 operates at temperatures greater than the LTR 409 and less than the high-temperature thermal reservoir HTR 406. The first portion then exits the medium-temperature heat reservoir MTR 412 in a seventh state at a seventh temperature T_7 and at a seventh pressure P_7 .

[063] After the first portion exits the MTR 412 in the seventh state and the second portion exits the recuperator RCX in the fifth state, the first and second portions combine at a point 425. After combining, the working fluid is in an eighth state at an eighth pressure P_8 and an eighth temperature T_8 as set forth in Table 2. The combination of the first portion and the second portion, or the "combined portion", then enters the expander 418 in the eighth state at the eighth pressure P_8 and the eighth temperature T_8 , whereupon it is expanded and cooled. The combined portion of the working fluid exits the expander 418 in a ninth state at a ninth temperature T_9 and a ninth pressure P_9 .

[064] The working fluid then enters the LTR 409 in the ninth state at the ninth temperature T_9 and the ninth pressure P_9 . In the LTR 409, heat is transferred from the LTR 409 to the working fluid. Note that the LTR 409 operates at temperatures lower than the medium temperature thermal reservoir MTR 412 and the high-temperature thermal reservoir HTR 406 as indicated in Table 2. The working fluid leaves the LTR 409 in a tenth state at a tenth temperature T_{10} and a tenth pressure P_{10} .

[065] Upon exit from the LTR 409, the working fluid enters the recuperator RCX in the tenth state at the tenth temperature T_{10} and the tenth pressure P_{10} and exits in the first state at the first temperature T_1 and the first pressure P_1 . In the recuperator RCX, heat is transferred from the working fluid on the high-pressure side to the working fluid on the low-pressure side of the recuperator RCX. Table 2 confirms (1) the temperature drop in the working fluid on the high-pressure side 404 as it transitions from the fourth state to the fifth state and (2) the temperature rise in the working fluid on the low-pressure side 405 as it transitions from the tenth state to the first state. The working fluid then begins again the circulation through the working fluid circuit 403 discussed immediately above.

[066] Turning now to FIG. 4B, the configuration of the working fluid circuit 403 in the generating phase of the PTES operational cycle is shown. The operating conditions at various points in the working fluid circuit 403 are listed in Table 3. As discussed above, the flow direction of the working fluid through the working fluid circuit 403 is reversed relative to that in the charging phase of the operational cycle. Note that the expander 419 and the charge compressor 421 in the charging phase configuration of FIG. 4A have been replaced by a pump 450 and a power turbine 453, respectively. As can be seen from comparing states 1 and 2 in Table 3 and states 9 and 10 in Table 3, the pump 450 pressurizes the working fluid and the power turbine 453 depressurizes the working fluid.

[067] The high-pressure side 404 of the working fluid circuit 403 therefore extends, in this phase of the operational cycle, from the outlet 451 of the pump 450 to the inlet 454 of the power turbine 453. The low-pressure side 405 extends from the outlet 455 of the power turbine 453 to the inlet 452 of the pump 450. Note that the high-pressure side 404 includes the bypass 415, the line 427, the point 425, and the point 424. The high-pressure side 404 of the recuperator RCX is once again defined by the ports 426, 430 and the low-pressure side 405 of the recuperator RCX is once again defined by the ports 433, 436.

Table 3. Generating Phase Operating Conditions

State	Out	In	H (kJ/kg)	P (MPa)	T (°C)	S (kJ/kg/K)	w (kg/sec)
1	LTX	Pump	204.69	3.87	2.00	1.016	79.71
2	Pump	Split1	234.60	29.23	21.52	1.027	79.71
3	Split1A	RCXI	234.60	29.23	21.52	1.027	27.12
4	RCXI	Mix1A	413.93	29.13	109.95	1.558	27.12
5	Split1B	MTR	234.60	29.23	21.52	1.027	52.58
6	MTR	Mix1B	358.20	29.13	83.04	1.408	52.58
7	Mix1	HTR	377.17	29.13	92.12	1.460	79.71
8	HTR	PT	747.69	28.93	327.50	2.262	79.71
9	PT	RCXh	589.50	4.07	139.10	2.296	79.71
10	RCXh	ACC	528.48	3.97	81.58	2.141	79.71
11	ACC	LTX	454.38	3.92	20.00	1.912	79.71

[068] Beginning with the LTR 409, the working fluid exits the LTR 409 and enters the pump 450 in a first state at a first temperature T_1 and a first pressure P_1 . The pump 450 provides the motive force for circulation in the generating phase. The working fluid exits the pump 450 in a second state at a second temperature T_2 and a second pressure P_2 .

[069] The working fluid, upon exiting the pump 450 in the second state, splits at the point 425 into a first portion and a second portion. Note that, in the charging phase illustrated in FIG. 4A, the two portions of the working fluid split at the point 424 and combine at the point 425. However, since the flow direction of the working fluid is reversed in the generating phase relative to the charging phase, the two portions split at the point 425 and combine at the point 424.

[070] The second portion enters the line 428 after the split at the point 425. The second portion enters the line 428 in a third state at a third temperature T_3 and a third pressure P_3 . Reference to Table 2 shows that the third state is at the second temperature and the second pressure—that is, the third temperature T_3 and the third pressure are the same as the second temperature and the second pressure. The third state nevertheless differs from the second state by having a significantly lower mass flow rate than does the second state. The second portion then circulates through the recuperator RCX from the high-pressure side 404 thereof, entering through the port 430 and exiting through the port 426. The second portion enters the recuperator RCX in the third state at the third temperature

and the third pressure and exits in a fourth state at a fourth temperature and a fourth pressure.

[071] After splitting at the point 425, the first portion of the working fluid enters the bypass 415 in a fifth state at a fifth temperature T_5 and fifth pressure P_5 . The first portion enters the MTR 412 in the fifth state at the fifth temperature T_5 and the fifth pressure P_5 . In the MTR 412, heat is transferred MTR 412 from the medium temperature thermal reservoir MTR 412 to the first portion. The first portion then exits the MTR 412 in a sixth state at a sixth temperature T_6 and at a sixth pressure P_6 .

[072] The first portion in the sixth state and the second portion in the fourth state, upon leaving the MTR 412 and the recuperator RCX, respectively, combine at the point 424. Note again that, in the charging phase illustrated in FIG. 4A, the two portions of the working fluid split at the point 424 and combine at the point 425. However, since the flow direction of the working fluid is reversed in the generating phase relative to the charging phase, the two portions split at the point 425 and combine at the point 424. The combined portion of the working fluid after the point 424 is in a seventh state at a seventh temperature T_7 and a seventh pressure P_7 .

[073] The combined portion then enters the high-temperature reservoir HTR 406 in the seventh state at the seventh temperature T_7 and the seventh pressure P_7 . In the high-temperature reservoir HTR 406, heat is transferred from the high-temperature thermal reservoir HTR 406 to the combined portion. The combined portion then exits the high-temperature reservoir HTR 406 in an eighth state at an eighth temperature T_8 and an eighth pressure P_8 .

[074] The combined portion of the working fluid then enters the power turbine 453 in the ninth state at the eighth temperature T_8 and the eighth pressure P_8 . More particularly, the combined portion enters the power turbine 453 from the high-pressure side 404 of the working fluid circuit 403 through the inlet 454. The power turbine 453 expands the working fluid, which cools and reduces the pressure of the combined portion. The combined portion then exits the power turbine 453 in a ninth state at a ninth temperature T_9 and a

ninth pressure P_9 . More particularly, the combined portion exits the power turbine to the low-pressure side 405 of the working fluid circuit 403 through the outlet 455.

[075] The combined portion then circulates through the low-pressure side of the recuperator RCX via the ports 433, 436. In the recuperator RCX, heat is exchanged between the second portion of the working fluid entering the recuperator RCX from the high-pressure side thereof as described above and the combined portion entering the recuperator RCX from the low-pressure side thereof. The combined portion then exits the recuperator RCX in a tenth state at a tenth temperature T_{10} and a tenth pressure P_{10} . The combined portion then enters the air-cooled cooler ACC in the tenth state at the tenth temperature T_{10} and the tenth pressure P_{10} . The air-cooled cooler ACC then cools the combined portion to an eleventh state at an eleventh temperature T_{11} and an eleventh pressure P_{11} .

[076] The combined portion then enters the LTR 409 in the eleventh state at the eleventh temperature T_{11} and the eleventh pressure P_{11} . In the LTR 409, heat is transferred from the LTR 409 from the combined portion to the LTR 409 of the LTR 409. The combined portion then leaves the LTR 409 in the first state at the first temperature and the first pressure to recirculate through the working fluid circuit 403 as just discussed.

[077] As was mentioned above, the configuration of the working fluid circuit 403 between the charging phase shown in FIG. 4 and the charging phase shown in FIG. 4B may be controlled by fluid flow valves. Although such control systems are readily known to those in the art, one such control system 500 is shown in FIG. 5 for the sake of completeness. The control system 500 may include a plurality of fluid flow valves 505 and a controller 510 sending control signals over electrical lines 515.

[078] The controller 510 includes a processor-based resource 520 that may be, for example and without limitation, a microcontroller, a microprocessor, an Application Specific Integrated Circuit ("ASIC"), an Electrically Erasable Programmable Read-Only Memory ("EEPROM"), or the like. Depending on the implementation of the processor-based resource, the controller 510 may also include a memory 525 encoded with instructions (not shown) executable by the processor-based resource 520 to implement

the functionality of the controller 510. Again, depending on the implementation of the processor-based resource 520, the memory 525 may be a part of the processor-based resource 520 or a stand-alone device. For example, the instructions may be firmware stored in the memory portion of a microprocessor or they may be a routine stored in a stand-alone read-only or random-access memory chip. Similarly, in some implementations of the processor-based resource 520—*e.g.*, an ASIC—the memory 535 may be omitted altogether.

[079] Referring now collectively to FIG. 4A-FIG. 4B and FIG. 5, a controller such as the controller 510 may be used to configure the working fluid circuit 403 between the charging phase as shown in FIG. 4A and generating phase shown in FIG. 4B. The controller 510 may send control signals to the fluid flow valves 505 to control the working fluid flow. Thus, to configure the working fluid circuit 403 for the charging phase, the controller 510 controls the fluid flow valves 505 to direct the working fluid to the charge compressor 421 and the expander 418 while diverting the working fluid away from the power turbine 453 and the pump 450. Conversely, to configure the working fluid circuit 403 for the generating phase, the controller 510 controls the fluid flow valves 505 to direct working fluid to the power turbine 453 and the pump 450 while diverting the working fluid away from the charge compressor 421 and the expander 418.

[080] Referring now, collectively, to FIG. 4A-FIG. 4B, the high-pressure side 404 of the working fluid circuit 403 includes the bypass 415 in both the charging phase and the operational phase. Thus, the bypass 415, including the heat exchanger (not shown) of the MTR 412, is on the high-pressure side of the recuperator RCX in both phases. The working fluid splits before entering the recuperator RCX at the point 424 in the charging phase and at the point 425 in the generating phase. The first portion bypasses the high-pressure-side of the recuperator RCX through the bypass 415 while the second side enters the recuperator RCX. The first and second portions then combine after the second portion passes through the recuperator RCX at the point 425 in the charging phase and at the point 424 in the generating phase.

[081] Splits and combinations in the high-pressure side 404 of the working fluid circuit 402 occur at the points 424, 425 in the illustrated embodiment. However, whether the points 424, 425 are split points or combination points will depend on whether the operating cycle is in the charging phase or in the generating phase. In the charging phase, the point 424 is a split point and in the generating phase it is the combination point. Conversely, the point 425 is the combination point in the charging phase and the splitting point in the generating phase. Note that alternative embodiments may have split and combination points in addition to or *in lieu* of those disclosed herein. This is particularly true in the pursuit of design goals unrelated to implementing the technique disclosed herein.

[082] The objective is to balance the product of the mass and the specific heat capacity on the low-pressure side 405 of the recuperator RCX with the product of the mass and the specific heat capacity on the high-pressure side 404 of the recuperator RCX. The term “balanced” means that the product of the mass and specific heat capacity on both sides of the recuperator RCX are equal. However, this may be difficult to achieve with precision in practice for a variety of reasons. Thus, the two products are “balanced” when they are “about”, “roughly”, or “approximately” equal in the sense that they are both within some margin for error in which the operation of the overall system achieves some desired level of efficiency. The desired level of efficiency may be expressed as a range of values to accommodate these types of concerns.

[083] Similarly, the terms “about”, “approximately”, *etc.* relative to any quantity in this disclosure indicates that some deviation from the stated quantity may be tolerated so long as the actual quantity is within some margin for error in which the operation of the overall system achieves some desired level of efficiency. For example, in the illustrated embodiment, the first portion may be 40% and the second portion may be 60% of the total, combined working fluid as will be discussed in more detail below. In any given embodiment employing CO₂ for the working fluid, a precise split in these proportions may be difficult to achieve. Hence, some deviation may be tolerated so long as the proportions are “about” or “approximately” 40% and 60%. The same is true of any other quantity discussed or disclosed herein.

[084] Those in the art having the benefit of this disclosure will appreciate that both the mass flow rate and the specific heat capacity in any given embodiment will be implementation-specific depending on factors such as, for example, the choice for implementing the working fluid. Other factors, such as the operational ranges of pumps, expanders, compressors, *etc.* may impact the operating conditions for various portions of the working fluid circuit. Thus, the various quantities for the parameters in Table 2 and Table 3 may differ in alternative embodiments employing different substances for the working fluid or that implement certain equipment differently.

[085] As noted above, the working fluid in the illustrated embodiment is CO₂. When the working fluid is split as previously described, the first portion is 40% of the total working fluid and the second portion is 60% of the total working fluid. This is true in both the charging phase and in the generating phase. In alternative embodiments using different working fluids or different mass flow rates this proportion may be changed to maintain the balance of the mass flow rate and the specific heat on both the high-pressure side and the low-pressure side of the recuperator.

[086] Accordingly, in a first embodiment, a method for operating a pumped thermal energy storage (“PTES”) system, the method comprises: circulating a working fluid through a working fluid circuit, the working fluid having a mass flow rate and a specific heat capacity; and balancing a product of the mass and the specific heat capacity of the working fluid on a high-pressure side of a recuperator and a low side of the recuperator as the working fluid circulates through the working fluid circuit.

[087] In a second embodiment, the first embodiment balances the product of the mass and the specific heat capacity of the working fluid on the high-pressure side of the recuperator and the low side of the recuperator as the working fluid circulates through the working fluid circuit by: splitting the working fluid into a first portion and a second portion on the high-pressure side of the recuperator; bypassing the first portion around the high-pressure side of the recuperator; cooling the first portion during the bypass; circulating the second portion through a recuperator; and combining the cooled first portion with the second portion after the second portion exits the recuperator.

[088] In a third embodiment, the second embodiment cools the first portion during the bypass by circulating the working fluid through the bypass; and transferring heat between the working fluid and a medium temperature thermal reservoir. The heat transfer includes, in a charging phase, transferring heat from a low-temperature thermal reservoir to the working fluid and transferring heat from the working fluid to a medium-temperature thermal reservoir and high-temperature thermal reservoir and, in a generating phase, transferring heat from a high-temperature thermal reservoir and a medium temperature thermal reservoir (hot) to the working fluid and transferring heat from the working fluid to a low-temperature thermal reservoir.

[089] In a fourth embodiment, the second embodiment may be implemented such that the first portion of the working fluid comprises 40% of the working fluid portion and the second portion comprises 60% of the working fluid portion.

[090] In a fifth embodiment, the first embodiment may be implemented such that circulating the working fluid through the working fluid circuit includes circulating carbon dioxide (CO₂), the first portion of the working fluid comprises 40% of the working fluid portion, and the second portion comprises 60% of the working fluid portion.

[091] In a sixth embodiment, the second embodiment may be implemented such that circulating the working fluid through the working fluid circuit includes circulating carbon dioxide (CO₂).

[092] In a seventh embodiment, the first embodiment may be implemented such that balancing a product of the mass and the specific heat capacity of the working fluid on the high-pressure side of a recuperator and the low side of the recuperator includes a charging phase and a generating phase. The charging phase includes circulating 60% of a working fluid comprised of carbon dioxide (CO₂) through the high-pressure side of a recuperator and circulating 100% of a working fluid comprised of CO₂ through the low-pressure side of the recuperator. The generating phase includes circulating 60% of a working fluid comprised of CO₂ through the high-pressure side of a recuperator and circulating 100% of a working fluid comprised of CO₂ through the low-pressure side of the recuperator.

[093] In an eighth embodiment, the first embodiment may be implemented such that balancing the product of the mass and the specific heat capacity of the working fluid on the high-pressure side of the recuperator and the low side of the recuperator as the working fluid circulates through the working fluid circuit includes reducing the mass flow rate on the high-pressure side of the recuperator.

[094] In a ninth embodiment, the first embodiment further comprises exchanging heat between the second portion of the working fluid on the high-pressure side of the recuperator and a combined portion of the working fluid on the low-pressure side of the recuperator.

[095] In a tenth embodiment, a pumped thermal energy storage (“PTES”) system, comprises a medium temperature thermal reservoir and a working fluid circuit. The working fluid circuit includes a recuperator having a high-pressure side and a low-pressure side, the product of the mass and the specific heat capacity of a working fluid is balanced on the high-pressure side and the low-pressure side when the working fluid circulates through the working fluid circuit.

[096] In an eleventh embodiment, the tenth embodiment may be implemented such that the working fluid is carbon dioxide (CO₂).

[097] In a twelfth embodiment, the tenth embodiment may be implemented such that the working fluid circuit includes a bypass by which a first portion of the working fluid bypasses the high-pressure side of the recuperator while a second portion of the working fluid circulates through the high-pressure side of the recuperator.

[098] In a thirteenth embodiment, the eleventh embodiment may be implemented such that the bypass includes a heat transfer between the first portion and the medium temperature thermal reservoir. Furthermore, the working fluid circuit further includes: a split on the high-pressure side of the recuperator splitting the working fluid into the first portion and the second portion, the first portion being less than the second portion, the second portion circulating through the recuperator from the high-pressure side of the recuperator; and a combination point on the high-pressure side of the recuperator where

the first portion combines with the second portion upon the second portion exiting the recuperator.

[099] In a fourteenth embodiment, the eleventh embodiment may be implemented such that the first portion is 40% of the total working fluid and the second portion is 60% of the total working fluid.

[0100] In a fifteenth embodiment, the eleventh embodiment may be implemented such that the working fluid is carbon dioxide (CO₂), the first portion is 40% of the total working fluid, and the second portion is 60% of the total working fluid.

[0101] In a sixteenth embodiment, the tenth embodiment may be implemented such that, in operation, heat is exchanged between the second portion of the working fluid on the high side of the recuperator and a combined portion of the working fluid on the low-pressure side of the recuperator.

[0102] In a seventeenth embodiment, a method for operating a pumped thermal energy storage ("PTES") system includes circulating a working fluid through a working fluid circuit; and reducing a mass flow rate of the working fluid on a high-pressure side of a recuperator to balance a product of the mass and the specific heat of the working fluid on the high-pressure side and a low-pressure side of the recuperator while circulating the working fluid. The reducing may include bypassing the high-pressure side of the recuperator with a first portion of the working fluid and circulating a second portion of the working fluid through the high-pressure side of the recuperator.

[0103] In an eighteenth embodiment, the seventeenth embodiment may be implemented such that bypassing the high-pressure side of the recuperator includes: upon transferring heat between the working fluid and a high-temperature reservoir in a charging phase, bypassing the high-pressure side of a recuperator with a first portion of the working fluid and transferring heat from the first portion to a medium-temperature reservoir during the bypass while a second portion circulates through the recuperator, the first portion being less than the second portion; and upon exiting a pump in a generating phase, bypassing the high-pressure side of the recuperator with a third portion of the working fluid while

transferring heat from the medium-temperature reservoir to the third portion during the bypass while circulating a fourth portion of the working fluid through the recuperator.

[0104] In a nineteenth embodiment, the seventeenth embodiment may include exchanging heat between the second portion of the working fluid on the high side of the recuperator and a combined portion of the working fluid on the low-pressure side of the recuperator.

[0105] In a twentieth embodiment, the seventeenth embodiment may be implemented such that reducing the mass flow rate of the working fluid on the high-pressure side of the recuperator to balance the product of the mass and the specific heat of the working fluid on the high-pressure side and the low-pressure side of the recuperator while circulating the working fluid further includes: splitting the working fluid into the first portion and the second portion on the high-pressure side of the recuperator, the first portion being less than the second portion; cooling the first portion during the bypass; and combining the cooled first portion with the second portion after the second portion exits the recuperator.

[0106] In a twenty-first embodiment, the twentieth embodiment may be implemented such that cooling the first portion during the bypass includes transferring heat between the working fluid and a medium temperature thermal reservoir. Transferring the heat may further include: in a charging phase, transferring heat from the working fluid to a medium temperature thermal reservoir and, in a generating phase, transferring heat from a medium temperature thermal reservoir to the working fluid.

[0107] In a twenty-second embodiment, the seventeenth embodiment may be implemented such that circulating the working fluid through the working fluid circuit includes circulating carbon dioxide (CO₂).

[0108] In a twenty-third embodiment, the seventeenth embodiment may be implemented such that the first portion of the working fluid comprises 40% of the working fluid portion and the second portion comprises 60% of the working fluid portion.

[0109] In a twenty-fourth embodiment, the seventeenth embodiment may be implemented such that circulating the working fluid through the working fluid circuit includes circulating

carbon dioxide (CO₂) and the first portion of the working fluid comprises 40% of the working fluid portion and the second portion comprises 60% of the working fluid portion.

[0110] In a twenty-fifth embodiment, a pumped thermal energy storage (“PTES”) system, comprises a low-temperature reservoir, a high-temperature reservoir, a medium-temperature reservoir, and a working fluid circuit configurable for a charging phase and a generating phase of a PTES operating cycle and through which, in use, a working fluid circulates. The working fluid circuit may include a recuperator; when in the charging phase: an expander positioned between the recuperator and the low-temperature reservoir; and a charge compressor positioned between recuperator and the high-temperature heat reservoir; and when in the generating phase: a pump positioned between recuperator and the low-temperature heat reservoir; and a power turbine positioned between recuperator and the high-temperature heat reservoir; and a bypass, by which, in both the charging phase and the generating phase, a first portion of the working fluid bypasses the high-pressure side of the recuperator and flows through the medium-temperature thermal reservoir, the medium-temperature thermal reservoir transferring heat between the working fluid and the medium-temperature thermal reservoir, while a second portion of the working fluid circulates through the recuperator.

[0111] In a twenty-sixth embodiment, the twenty-fifth embodiment may be implemented such that the working fluid is carbon dioxide (CO₂).

[0112] In a twenty-seventh embodiment, the twenty-fifth embodiment may be implemented such that the first portion is 40% of the total working fluid and the second portion is 60% of the total working fluid.

[0113] In a twenty-eighth embodiment, the twenty-fifth embodiment may be implemented such that the working fluid is carbon dioxide (CO₂), the first portion is 40% of the total working fluid, and the second portion is 60% of the total working fluid.

[0114] In a twenty-ninth embodiment, a method for operating a pumped thermal energy storage (“PTES”) system, the method comprises: circulating a high-heat capacity working fluid through a working fluid circuit including a recuperator; and reducing a mass flow rate

of the working fluid on the high-pressure side of the recuperator such that the product of mass and the specific heat capacity is the same on both sides of a recuperator. Reducing the mass flow rate may include, in a charging phase: bypassing a recuperator with a first portion of the working fluid and transferring heat from the first portion to a medium-temperature reservoir during the bypass while circulating a second portion of the working fluid through the recuperator, the first portion being a lesser portion of the working fluid than the second portion; circulating a second portion through the recuperator while the first portion bypasses the recuperator and transferring heat from the second portion while circulating through the recuperator; and circulating both the first portion and the second portion together through an expander after the first portion bypasses the recuperator and the second portion circulates through the recuperator. Reducing the mass flow rate may include, in a generating phase: bypassing the recuperator with a third portion of the working fluid and transferring heat from the third portion to a medium-temperature reservoir during the bypass while circulating a fourth portion of the working fluid through the recuperator, the third portion being a greater portion than the fourth portion; circulating a fourth portion through the recuperator while the third portion bypasses the recuperator and transferring heat to the fourth portion while circulating through the recuperator; and circulating both the third portion and the fourth portion together through a high-temperature reservoir after the third portion bypasses the recuperator and the fourth portion circulates through the recuperator.

[0115] In a thirtieth embodiment, the twenty-ninth embodiment may be implemented such that the working fluid is carbon dioxide (CO₂).

[0116] In a thirty-first embodiment, the thirtieth embodiment may be implemented such that the first portion represents approximately 40%, the second portion represents approximately 60% of the mass flow rate of the working fluid in the charging phase, and the third portion represents approximately 40% and the fourth portion represents approximately 60% of the mass flow rate of the working fluid in the generating phase.

[0117] In a thirty-second embodiment, the twenty-ninth embodiment may be implemented such that the first portion represents approximately 40% and the second portion

represents approximately 60% of the mass flow rate of the working fluid in the charging phase and the third portion represents approximately 40% and the fourth portion represents approximately 60% of the mass flow rate of the working fluid in the generating phase.

[0118] Those skilled in the art having the benefit of this disclosure may appreciate still other embodiments of the technique disclosed herein.

[0119] The foregoing has outlined features of several embodiments so that those skilled in the art may better understand the present disclosure. Those skilled in the art should appreciate that they may readily use the present disclosure as a basis for designing or modifying other processes and structures for carrying out the same purposes and/or achieving the same advantages of the embodiments introduced herein. Those skilled in the art should also realize that such equivalent constructions do not depart from the spirit and scope of the present disclosure, and that they may make various changes, substitutions and alterations herein without departing from the spirit and scope of the present disclosure.

CLAIMS

What is claimed is:

1. A method for operating a pumped thermal energy storage (“PTES”) system, the method comprising:
 - circulating a working fluid through a working fluid circuit, the working fluid having a mass flow rate and a specific heat capacity; and
 - balancing a product of the mass and the specific heat capacity of the working fluid on a high-pressure side of a recuperator and a low side of the recuperator as the working fluid circulates through the working fluid circuit.

2. The method of claim 1, wherein balancing the product of the mass and the specific heat capacity of the working fluid on the high-pressure side of the recuperator and the low side of the recuperator as the working fluid circulates through the working fluid circuit includes:
 - splitting the working fluid into a first portion and a second portion on the high-pressure side of the recuperator;
 - bypassing the first portion around the high-pressure side of the recuperator;
 - cooling the first portion during the bypass;
 - circulating the second portion through a recuperator; and
 - combining the cooled first portion with the second portion after the second portion exits the recuperator.

3. The method of claim 2, wherein cooling the first portion during the bypass includes:
 - circulating the working fluid through the bypass; and
 - transferring heat between the working fluid and a medium temperature thermal reservoir, including:
 - in a charging phase, transferring heat from the working fluid to a medium-temperature thermal reservoir; and

in a generating phase, transferring heat from a medium-temperature thermal reservoir to the working fluid.

4. The method of claim 2, wherein the first portion of the working fluid comprises approximately 40% of the working fluid portion and the second portion comprises approximately 60% of the working fluid portion.
5. The method of claim 1, wherein:
 - circulating the working fluid through the working fluid circuit includes circulating carbon dioxide (CO₂);
 - the first portion of the working fluid comprises approximately 40% of the working fluid portion; and
 - the second portion comprises approximately 60% of the working fluid portion.
6. The method of claim 2, wherein circulating the working fluid through the working fluid circuit includes circulating carbon dioxide (CO₂).
7. The method of claim 1, wherein balancing a product of the mass and the specific heat capacity of the working fluid on the high-pressure side of a recuperator and the low side of the recuperator includes:
 - in a charging phase:
 - circulating approximately 60% of a working fluid comprised of carbon dioxide (CO₂) through the high-pressure side of a recuperator; and
 - circulating 100% of a working fluid comprised of CO₂ through the low-pressure side of the recuperator; and
 - in a generating phase:
 - circulating approximately 60% of a working fluid comprised of CO₂ through the high-pressure side of a recuperator; and
 - circulating 100% of a working fluid comprised of CO₂ through the low-pressure side of the recuperator.

8. The method of claim 1, wherein balancing the product of the mass and the specific heat capacity of the working fluid on the high-pressure side of the recuperator and the low side of the recuperator as the working fluid circulates through the working fluid circuit includes reducing the mass flow rate on the high-pressure side of the recuperator.
9. The method of claim 1, further comprising exchanging heat between the second portion of the working fluid on the high side of the recuperator and a combined portion of the working fluid on the low-pressure side of the recuperator.
10. A pumped thermal energy storage ("PTES") system, comprising:
 - a medium temperature thermal reservoir; and
 - a working fluid circuit, including:
 - a recuperator having a high-pressure side and a low-pressure side, the product of the mass and the specific heat capacity of a working fluid is balanced on the high-pressure side and the low-pressure side when the working fluid circulates through the working fluid circuit.
11. The system of claim 10, wherein the working fluid is carbon dioxide (CO₂).
12. The system of claim 10, wherein the working fluid circuit includes a bypass by which a first portion of the working fluid bypasses the high-pressure side of the recuperator while a second portion of the working fluid circulates through the high-pressure side of the recuperator.
13. The system of claim 10, wherein:
 - the bypass includes a heat transfer between the first portion and the medium temperature thermal reservoir; and
 - the working fluid circuit further comprises:
 - a split on the high-pressure side of the recuperator splitting the working fluid into the first portion and the second portion, the first portion being

less than the second portion, the second portion circulating through the recuperator from the high-pressure side of the recuperator; and a combination point on the high-pressure side of the recuperator where the first portion combines with the second portion upon the second portion exiting the recuperator.

14. The system of claim 10, wherein the first portion is approximately 40% of the total working fluid and the second portion is approximately 60% of the total working fluid.
15. The system of claim 10, wherein:
 - the working fluid is carbon dioxide (CO₂);
 - the first portion is approximately 40% of the total working fluid; and
 - the second portion is approximately 60% of the total working fluid.
16. The system of claim 10, further wherein, in operation, heat is exchanged between the second portion of the working fluid on the high side of the recuperator and a combined portion of the working fluid on the low-pressure side of the recuperator.
17. A method for operating a pumped thermal energy storage ("PTES") system, the method comprising:
 - circulating a working fluid through a working fluid circuit; and
 - reducing a mass flow rate of the working fluid on a high-pressure side of a recuperator to balance a product of the mass and the specific heat of the working fluid on the high-pressure side and a low-pressure side of the recuperator while circulating the working fluid, including:
 - bypassing the high-pressure side of the recuperator with a first portion of the working fluid; and
 - circulating a second portion of the working fluid through the high-pressure side of the recuperator.

18. The method of claim 17, wherein bypassing the high-pressure side of the recuperator includes:

upon transferring heat between the working fluid and a high-temperature reservoir in a charging phase, bypassing the high-pressure side of a recuperator with a first portion of the working fluid and transferring heat from the first portion to a medium-temperature reservoir during the bypass while a second portion circulates through the recuperator, the first portion being less than the second portion; and

upon exiting a pump in a generating phase, bypassing the high-pressure side of the recuperator with a third portion of the working fluid while transferring heat from the medium-temperature reservoir to the third portion during the bypass while circulating a fourth portion of the working fluid through the recuperator.

19. The method of claim 17, further comprising exchanging heat between the second portion of the working fluid on the high side of the recuperator and a combined portion of the working fluid on the low-pressure side of the recuperator.

20. The method of claim 17, wherein reducing the mass flow rate of the working fluid on the high-pressure side of the recuperator to balance the product of the mass and the specific heat of the working fluid on the high-pressure side and the low-pressure side of the recuperator while circulating the working fluid further includes:

splitting the working fluid into the first portion and the second portion on the high-pressure side of the recuperator, the first portion being less than the second portion;

transferring heat to and from the first portion during the bypass; and

combining the first portion with the second portion after the second portion exits the recuperator.

21. The method of claim 20, wherein transferring heat to and from the first portion during the bypass includes transferring heat between the working fluid and a medium temperature thermal reservoir, further including:
- in a charging phase, transferring heat from the working fluid to a medium temperature thermal reservoir; and
 - in a generating phase, transferring heat from a medium temperature thermal reservoir to the working fluid.
22. The method of claim 17, wherein circulating the working fluid through the working fluid circuit includes circulating carbon dioxide (CO₂).
23. The method of claim 17, wherein the first portion of the working fluid comprises approximately 40% of the working fluid portion and the second portion comprises approximately 60% of the working fluid portion.
24. The method of claim 17, wherein:
- circulating the working fluid through the working fluid circuit includes circulating carbon dioxide (CO₂); and
 - the first portion of the working fluid comprises approximately 40% of the working fluid portion and the second portion comprises approximately 60% of the working fluid portion.
25. A pumped thermal energy storage (“PTES”) system, comprising:
- a low-temperature thermal reservoir;
 - a high-temperature thermal reservoir;
 - a medium-temperature thermal reservoir; and
 - a working fluid circuit configurable for a charging phase and a generating phase of a PTES operating cycle and through which, in use, a working fluid circulates, the working fluid circuit including:
 - a recuperator;
 - when in the charging phase:

an expander positioned between the recuperator and the low-temperature reservoir; and

a charge compressor positioned between recuperator and the high-temperature heat reservoir; and

when in the generating phase:

a pump positioned between recuperator and the low-temperature heat reservoir; and

a power turbine positioned between recuperator and the high-temperature heat reservoir; and

a bypass, by which, in both the charging phase and the generating phase, a first portion of the working fluid bypasses the high-pressure side of the recuperator and flows through the medium-temperature thermal reservoir, the medium-temperature thermal reservoir transferring heat between the working fluid and the medium-temperature thermal reservoir, while a second portion of the working fluid circulates through the recuperator.

26. The system of claim 25, wherein the working fluid is carbon dioxide (CO₂).
27. The system of claim 25, wherein the first portion is approximately 40% of the total working fluid and the second portion is approximately 60% of the total working fluid.
28. The system of claim 25, wherein:
the working fluid is carbon dioxide (CO₂);
the first portion is approximately 40% of the total working fluid; and
the second portion is approximately 60% of the total working fluid.
29. A method for operating a pumped thermal energy storage (“PTES”) system, the method comprising:
circulating a high-heat capacity working fluid through a working fluid circuit including a recuperator; and

reducing a mass flow rate of the working fluid on the high-pressure side of the recuperator such that the product of mass and the specific heat capacity is the same on both sides of a recuperator, including:

in a charging phase:

bypassing a recuperator with a first portion of the working fluid and transferring heat from the first portion to a medium-temperature reservoir during the bypass while circulating a second portion of the working fluid through the recuperator;

circulating a second portion through the recuperator while the first portion bypasses the recuperator and transferring heat from the second portion while circulating through the recuperator; and

circulating both the first portion and the second portion together through an expander after the first portion bypasses the recuperator and the second portion circulates through the recuperator; and

in a generating phase:

bypassing the recuperator with a third portion of the working fluid and transferring heat from the third portion to a medium-temperature reservoir during the bypass while circulating a fourth portion of the working fluid through the recuperator;

circulating a fourth portion through the recuperator while the third portion bypasses the recuperator and transferring heat to the fourth portion while circulating through the recuperator; and

circulating both the third portion and the fourth portion together through a high-temperature reservoir after the third portion bypasses the recuperator and the fourth portion circulates through the recuperator.

30. The method of claim 29, wherein the working fluid is carbon dioxide (CO₂).
31. The method of claim 30, wherein:
 - the first portion represents approximately 40%;
 - the second portion represents approximately 60% of the mass flow rate of the working fluid in the charging phase; and
 - the third portion represents approximately 40% and the fourth portion represents approximately 60% of the mass flow rate of the working fluid in the generating phase.
32. The method of claim 29, wherein:
 - the first portion represents approximately 40% and the second portion represents approximately 60% of the mass flow rate of the working fluid in the charging phase; and
 - the third portion represents approximately 40% and the fourth portion represents approximately 60% of the mass flow rate of the working fluid in the generating phase.

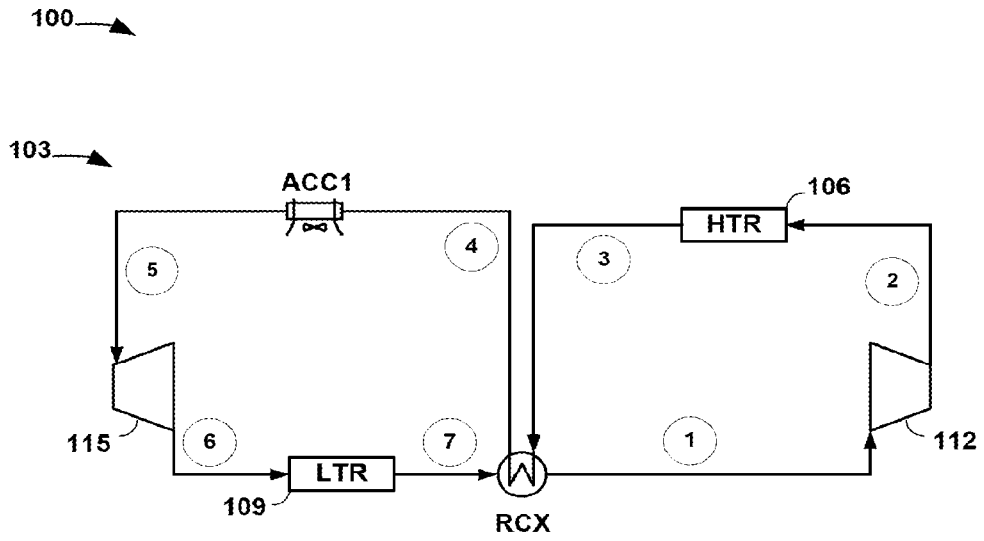

FIG. 1A

PRIOR ART

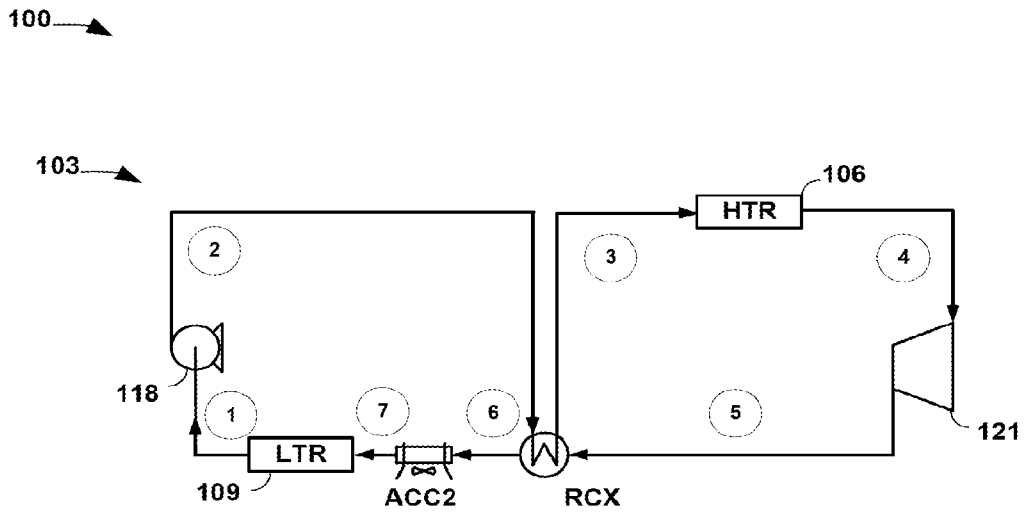

FIG. 1B

PRIOR ART

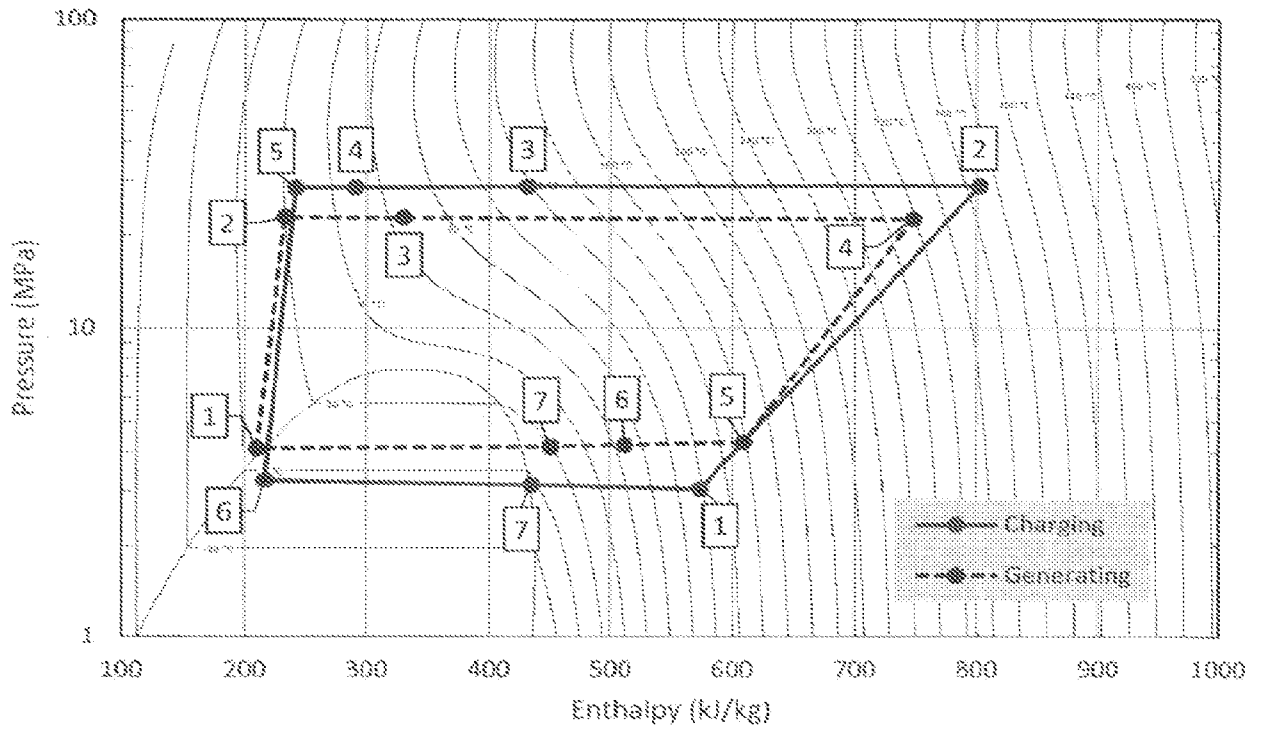

FIG. 2

PRIOR ART

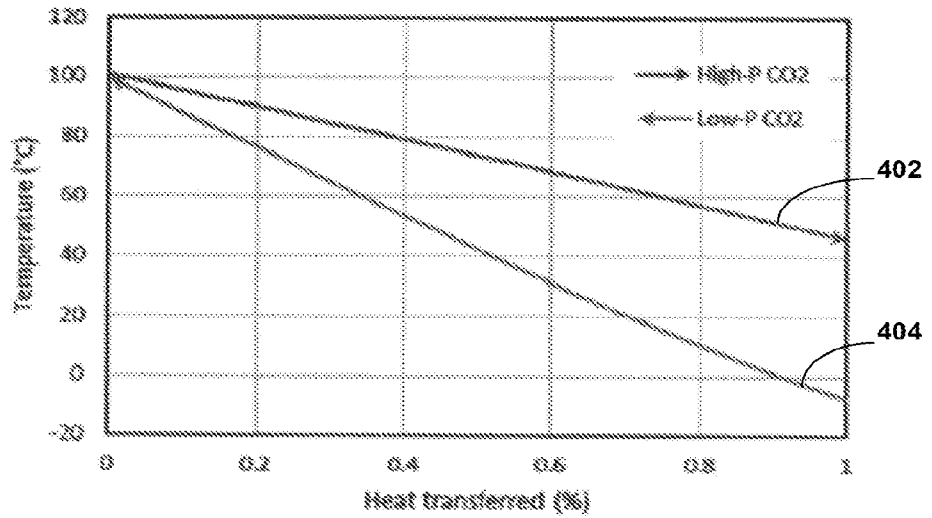

FIG. 3

PRIOR ART

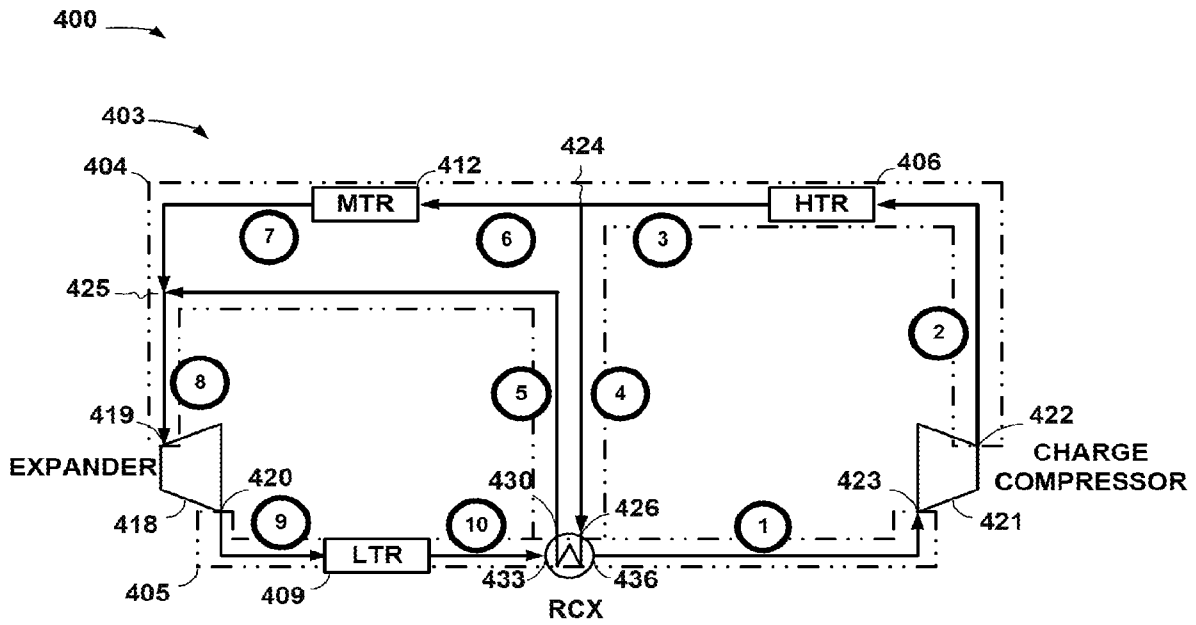

FIG. 4A

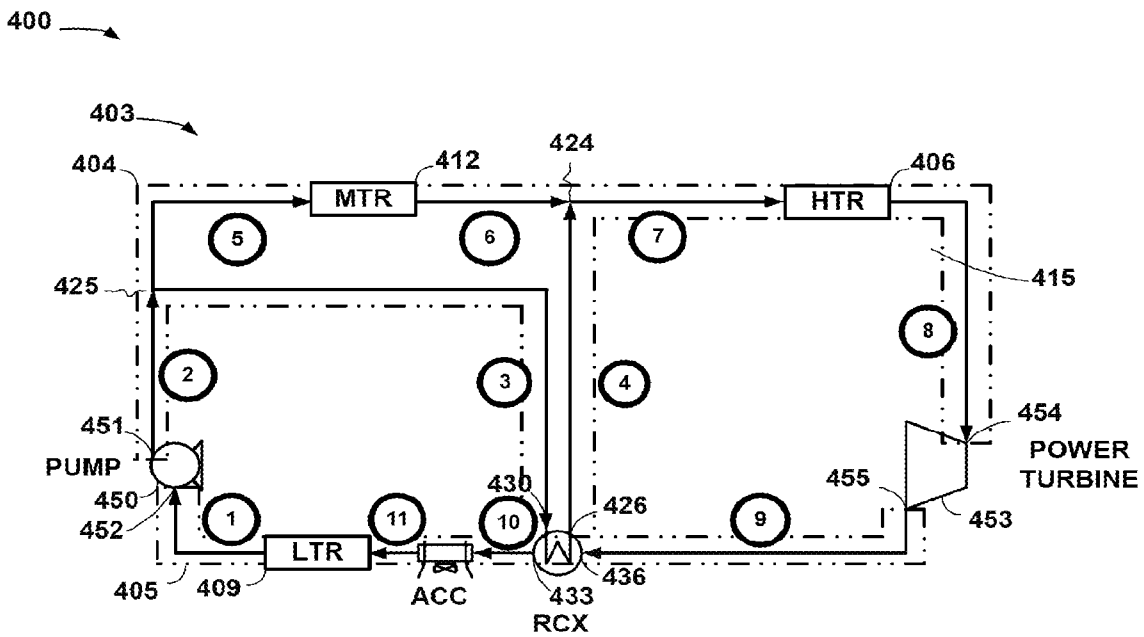

FIG. 4B

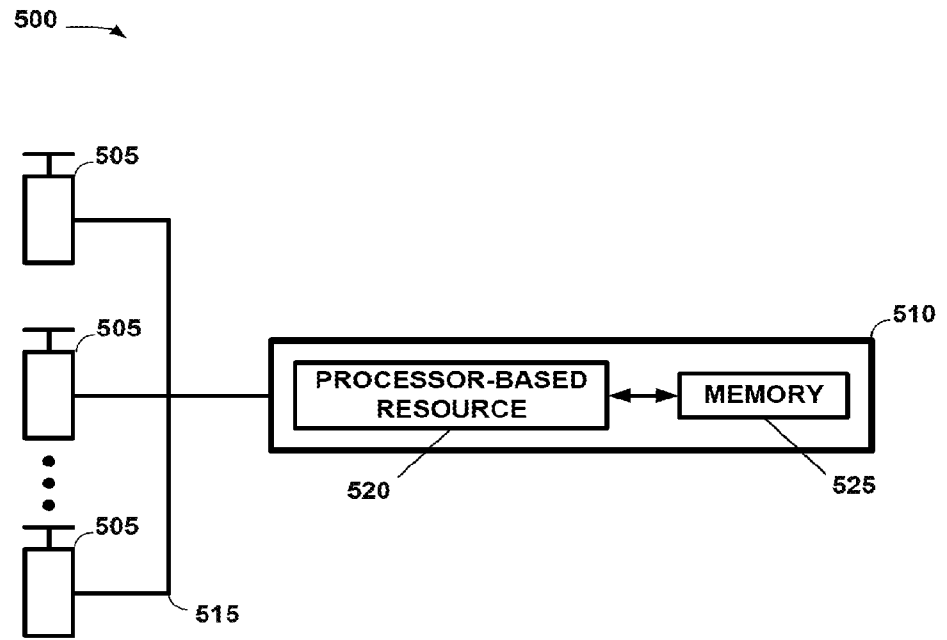

FIG. 5

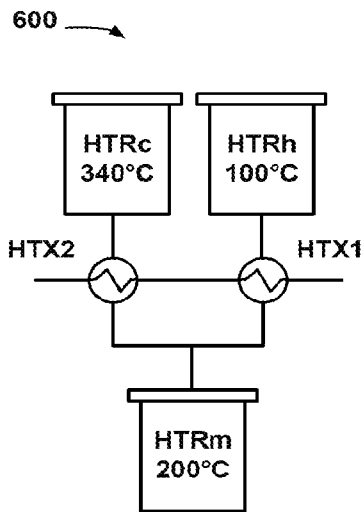

FIG. 6A

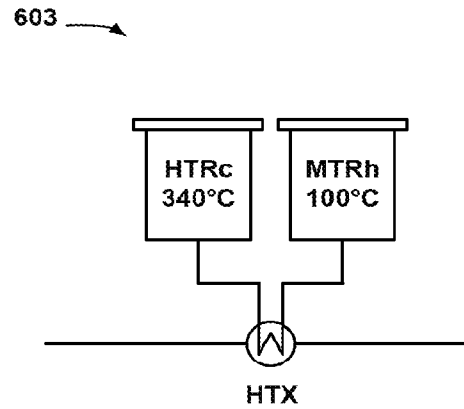

FIG. 6B

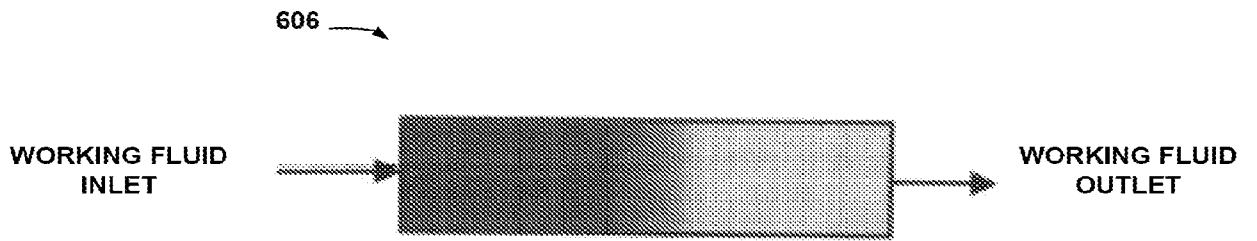

FIG. 6C

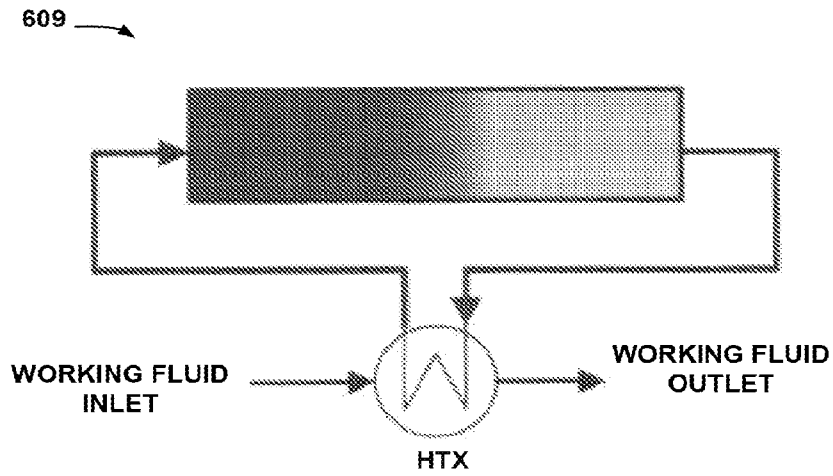

FIG. 6D

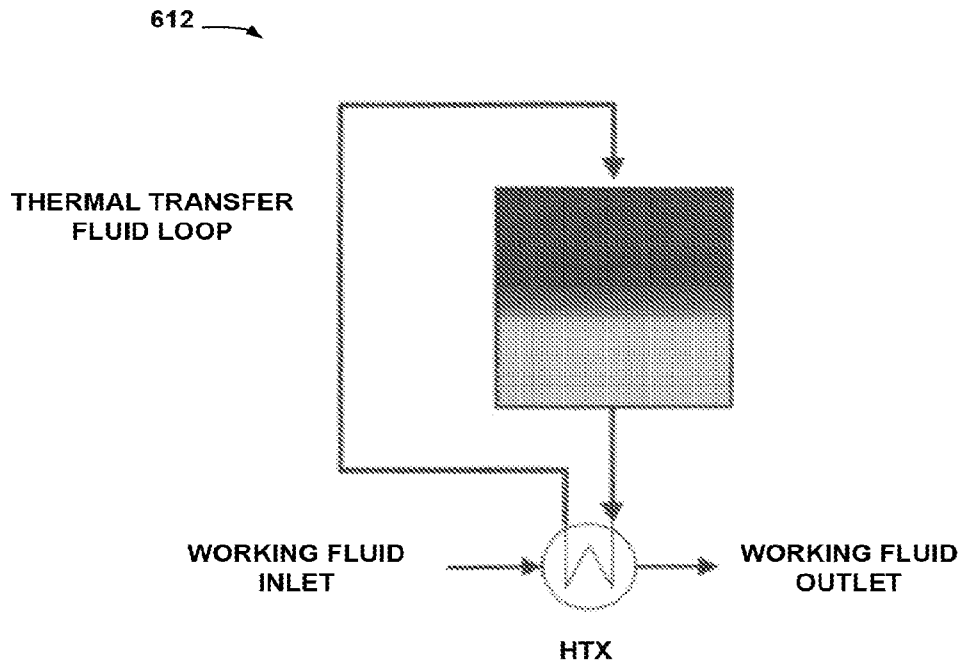

FIG. 6E

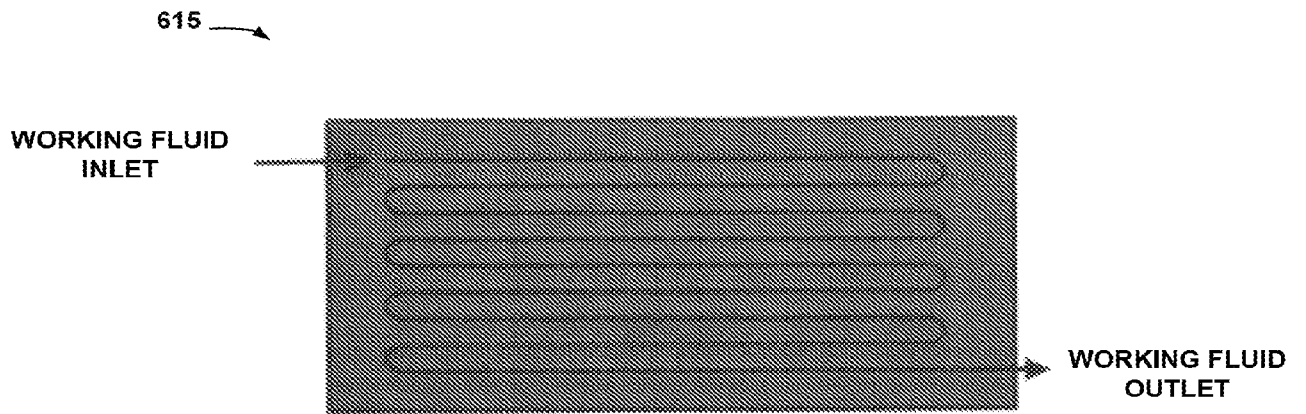

FIG. 6F

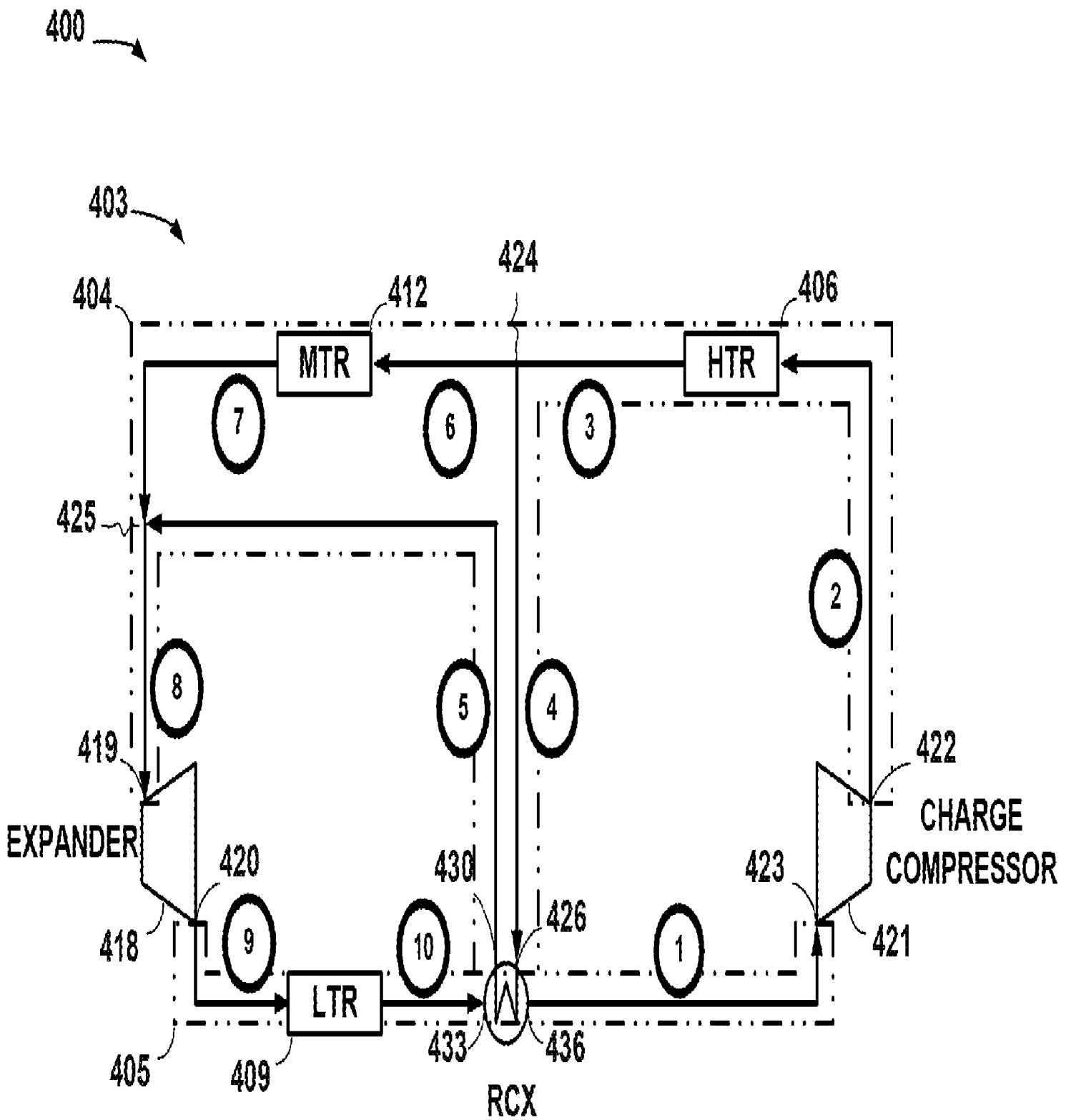

FIG. 4A