



- (51) International Patent Classification:
A61F 13/15 (2006.01)
- (21) International Application Number:
PCT/US2013/032737
- (22) International Filing Date:
18 March 2013 (18.03.2013)
- (25) Filing Language: English
- (26) Publication Language: English
- (30) Priority Data:
13/435,063 30 March 2012 (30.03.2012) US
- (71) Applicant: THE PROCTER & GAMBLE COMPANY
[US/US]; One Procter & Gamble Plaza, Cincinnati, Ohio
45202 (US).
- (72) Inventors: LAVON, Gary, Dean; 7071 Darcie Drive,
Liberty Township, Ohio 45011 (US). SCHNEIDER, Uwe;
520 Chisholm Trail, Cincinnati, Ohio 45215 (US).
- (74) Agent: GUFFEY, Timothy B.; c/o The Procter & Gamble
Company, Global Patent Services, 299 East 6th Street, Sy-
camore Building, 4th Floor, Cincinnati, Ohio 45202 (US).

(81) Designated States (unless otherwise indicated, for every kind of national protection available): AE, AG, AL, AM, AO, AT, AU, AZ, BA, BB, BG, BH, BN, BR, BW, BY, BZ, CA, CH, CL, CN, CO, CR, CU, CZ, DE, DK, DM, DO, DZ, EC, EE, EG, ES, FI, GB, GD, GE, GH, GM, GT, HN, HR, HU, ID, IL, IN, IS, JP, KE, KG, KM, KN, KP, KR, KZ, LA, LC, LK, LR, LS, LT, LU, LY, MA, MD, ME, MG, MK, MN, MW, MX, MY, MZ, NA, NG, NI, NO, NZ, OM, PA, PE, PG, PH, PL, PT, QA, RO, RS, RU, RW, SC, SD, SE, SG, SK, SL, SM, ST, SV, SY, TH, TJ, TM, TN, TR, TT, TZ, UA, UG, US, UZ, VC, VN, ZA, ZM, ZW.

(84) Designated States (unless otherwise indicated, for every kind of regional protection available): ARIPO (BW, GH, GM, KE, LR, LS, MW, MZ, NA, RW, SD, SL, SZ, TZ, UG, ZM, ZW), Eurasian (AM, AZ, BY, KG, KZ, RU, TJ, TM), European (AL, AT, BE, BG, CH, CY, CZ, DE, DK, EE, ES, FI, FR, GB, GR, HR, HU, IE, IS, IT, LT, LU, LV, MC, MK, MT, NL, NO, PL, PT, RO, RS, SE, SI, SK, SM, TR), OAPI (BF, BJ, CF, CG, CI, CM, GA, GN, GQ, GW, ML, MR, NE, SN, TD, TG).

Published:

— with international search report (Art. 21(3))

(54) Title: APPARATUSES AND METHODS FOR MAKING ABSORBENT ARTICLES

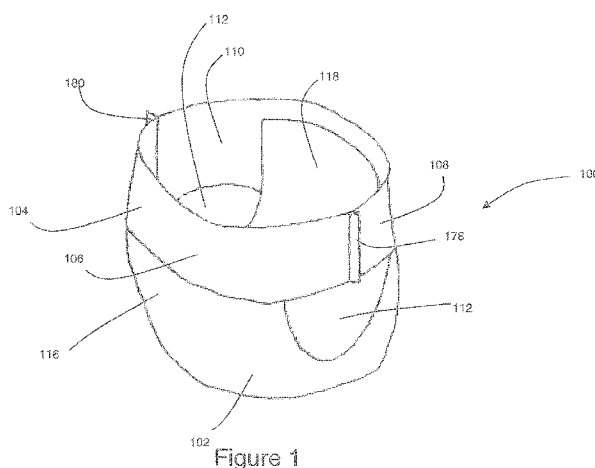

(57) Abstract: The present disclosure relates to methods and apparatuses for assembling diaper pants, each including a chassis connected with front and back elastic belts. Opposing end regions of the chassis may be connected with regions of the elastic belts where the elasticity of the elastic belts has been removed or deactivated. An elastic laminate may be formed by intermittently bonding elastic strands with a first continuous substrate, defining bonded regions and non bonded regions intermittently spaced along the machine direction. A second continuous substrate may be cut into discrete lengths or patches intermittently spaced along the machine direction. The discrete lengths of the second substrate may then be bonded with the first continuous substrate and elastic strands in the bonded regions. The elastic strands are then intermittently deactivated by severing the strands in the non bonded regions. And plurality of chassis may then be bonded with non bonded regions of the elastic laminate.



APPARATUSES AND METHODS FOR MAKING ABSORBENT ARTICLES

FIELD OF THE INVENTION

The present disclosure relates to methods for manufacturing absorbent articles, and more particularly, to apparatuses and methods for making elastic belts for diapers.

BACKGROUND OF THE INVENTION

Along an assembly line, various types of articles, such as for example, diapers and other absorbent articles, may be assembled by adding components to and/or otherwise modifying an advancing, continuous web of material. For example, in some processes, advancing webs of material are combined with other advancing webs of material. In other examples, individual components created from advancing webs of material are combined with advancing webs of material, which in turn, are then combined with other advancing webs of material. In some cases, individual components created from advancing web or webs are combined with other individual components created from other advancing web or webs. Webs of material and component parts used to manufacture diapers may include: backsheets, topsheets, leg cuffs, waist bands, absorbent core components, front and/or back ears, front and back belts, fastening components, and various types of elastic webs and components such as leg elastics, barrier leg cuff elastics, stretch side panels, and waist elastics. Once the desired component parts are assembled, the advancing web(s) and component parts are subjected to a final knife cut to separate the web(s) into discrete diapers or other absorbent articles.

Some diaper pant embodiments are configured with a chassis connected with front and back elastic belts, wherein opposing end regions of the front and back belts are connected with each other at side seams. In some instances, the elasticity of the front and back belts is removed in regions where the chassis connects with the belts. In some configurations, diapers may include graphics on the belts or in belt regions, and the absence of elasticity in such regions may allow for reduced distortion of graphics located in those regions. In addition, minimizing the number of belt layers overlapping the graphics may improve the visibility of the graphics from outside of the article. Thus, in some converting configurations adapted to assemble such diaper pants, stretched elastic strands are glued between two continuous nonwoven webs to form an elastic laminate. Regions of the elastic strands may then be intermittently deactivated along the length of the elastic laminate by cutting the elastic strands. Subsequent to deactivating the elastic strands, the elastic laminate may be subjected to additional handling and converting operations.

However, cutting the elastic strands may also damage other materials of the elastic laminate, for example the nonwoven webs, resulting in a relatively poor aesthetic appearance. In addition, the ends of the cut elastic strands may snap back in an uncontrolled fashion and consequently may end up in an undesired location within the laminate. Further, deactivating the
5 elastics in an elastic laminate may weaken the laminate, making the laminate relatively more likely to tear, and/or may otherwise result in control and handling difficulties associated with differential stretch characteristics within the laminate during subsequent processing. Consequently, it would be beneficial to provide methods and apparatuses that are configured to minimize handling of the elastic laminates after intermittently deactivating the elastics therein;
10 and/or assemble the elastic laminate in such a way to maximize the aesthetic appearance of the laminate when placed in an assembled product.

SUMMARY OF THE INVENTION

The present disclosure relates to methods and apparatuses for assembling diaper pants,
15 each including a chassis connected with front and back elastic belts. Opposing end regions of the chassis may be connected with regions of the elastic belts where the elasticity of the elastic belts has been removed or deactivated. An elastic laminate may be formed by intermittently bonding elastic strands with a first continuous substrate, defining bonded regions and non-bonded regions intermittently spaced along the machine direction. A second continuous substrate may be cut
20 into discrete lengths or patches intermittently spaced along the machine direction. The discrete lengths of the second substrate may then be bonded with the first continuous substrate and elastic strands in the bonded regions. The elastic strands are then intermittently deactivated by severing the strands in the non-bonded regions. And plurality of chassis may then be bonded with non-bonded regions of the elastic laminate.

25 In one form, a method may be adapted for assembling disposable pant diapers, each pant diaper comprising a chassis having having a first end region and an opposing second end region separated from each other by a central region, and having a longitudinal axis and a lateral axis, the chassis comprising: a topsheet, a backsheet, and an absorbent core disposed between the topsheet and the backsheet. The method includes the steps of: advancing a first continuous
30 substrate having a first surface and an opposing second surface in a machine direction, and defining a width in a cross direction; advancing a second continuous substrate having a first surface and an opposing second surface in a machine direction, and defining a width in a cross direction; cutting the second continuous substrate into discrete lengths of second substrate material; advancing elastic strands in the machine direction in a stretched state; intermittently

bonding the elastic strands in the stretched state between the first surface of the first substrate and the first surfaces of the discrete lengths of second substrate material to form an elastic laminate, the elastic laminate including bonded regions and non-bonded regions intermittently spaced along the machine direction, wherein the elastic strands are bonded to the first surface of the first substrate and the first surfaces of the discrete lengths of second substrate material in the bonded regions, and wherein the elastic strands are not bonded to the first substrate in the non-bonded regions; cutting the elastic laminate along the machine direction to form a first continuous elastic laminate and a second continuous elastic laminate, each of the first continuous elastic laminate and the second continuous elastic laminate including bonded regions and non-bonded regions; severing elastic strands in the non-bonded regions of the first continuous elastic laminate and the second elastic laminate; and bonding the first end regions of each chassis with non-bonded regions of first continuous elastic laminate, and bonding the second end regions of each chassis with non-bonded regions of the second continuous elastic laminate.

In another form, a method may be configured for assembling disposable pant diapers, each pant diaper comprising a chassis having a first end region and an opposing second end region separated from each other by a central region, and having a longitudinal axis and a lateral axis, the chassis comprising: a topsheet, a backsheet, and an absorbent core disposed between the topsheet and the backsheet. The method includes the steps of: advancing a first continuous substrate having a first surface and an opposing second surface in a machine direction, and defining a width in a cross direction; advancing a second continuous substrate having a first surface and an opposing second surface in a machine direction, and defining a width in a cross direction; cutting the second continuous substrate into discrete lengths of second substrate material; advancing elastic strands in the machine direction in a stretched state; intermittently bonding the elastic strands in the stretched state between the first surface of the first substrate and the first surfaces of the discrete lengths of second substrate material to form an elastic laminate, the elastic laminate including bonded regions and non-bonded regions intermittently spaced along the machine direction, wherein the elastic strands are bonded to the first surface of the first substrate and the first surfaces of the discrete lengths of second substrate material in the bonded regions, and wherein the elastic strands are not bonded to the first substrate in the non-bonded regions; and bonding the first end regions of each chassis with non-bonded regions of the elastic laminate.

BRIEF DESCRIPTION OF THE DRAWINGS

Figure 1 is a perspective view of a diaper pant.

Figure 2A is a partially cut away plan view of the diaper pant shown in Figure 1.

Figure 2B is a partially cut away plan view of a second embodiment of a diaper pant.

5 Figure 3A is a cross-sectional view of the diaper pants of Figures 2A and 2B taken along line 3A-3A.

Figure 3B is a cross-sectional view of the diaper pants of Figures 2A and 2B taken along line 3B-3B.

10 Figure 4 is a schematic side view of a converting apparatus adapted to manufacture diapers.

Figure 5A1 is a view of a continuous length of an elastic laminate from Figure 4 taken along line 5A1-5A1.

Figure 5A2 is a view of a continuous length of an elastic laminate from Figure 4 taken along line 5A2-5A2.

15 Figure 5A3 is a view of a continuous length of an elastic laminate from Figure 4 taken along line 5A3-5A3.

Figure 5B is a view of the elastic laminate from Figure 4 after being slit into first and second belt substrates separated from each other in the cross direction CD taken along line 5B-5B.

20 Figure 5B1 is a cross-sectional view of the first belt substrate from Figure 5B taken along line B1-B1.

Figure 5B2 is a cross-sectional view of the second belt substrate from Figure 5B taken along line B2-B2.

25 Figure 5B3 shows a detailed view of a belt substrate with the inner layer belt material cut-away to illustrate an embodiment of adhesive application.

Figure 5C is a view of continuous lengths of advancing first and second belt substrates material from Figure 4 taken along line 5C-5C.

Figure 5C1 is a cross-sectional view of the first belt substrate from Figure 5C taken along line C1-C1 showing elastics cut in non-bonded regions.

30 Figure 5C2 is a cross-sectional view of the second belt substrate from Figure 5C taken along line C2-C2 showing elastics cut in non-bonded regions.

Figure 5C3 shows a detailed view of the belt substrate from Figure 5C with the inner layer belt material cut-away to illustrate elastics after having been cut in the non-bonded regions.

Figure 5C1A is a cross-sectional view of the first belt substrate from Figure 5C taken along line C1-C1 showing elastics and outer belt material cut in non-bonded regions.

Figure 5C2A is a cross-sectional view of the second belt substrate from Figure 5C taken along line C2-C2 showing elastics and outer belt material cut in non-bonded regions.

5 Figure 5D is a view of a continuous length of chassis assemblies from Figure 4 taken along line 5D-5D.

Figure 5E1 is a view of a discrete chassis from Figure 4 taken along line 5E1-5E1.

Figure 5E2 is a view of a discrete chassis from Figure 4 taken along line 5E2-5E2.

Figure 5F is a view of multiple discrete chassis spaced from each other along the machine
10 direction MD and connected with each other by the first and second belt substrates from Figure 4 taken along line 5F-5F.

Figure 5G is a view of folded multiple discrete chassis with the first and second belt substrates in a facing relationship from Figure 4 taken along line 5G-5G.

Figure 5H is a view of two discrete absorbent articles advancing the machine direction
15 MD from Figure 4 taken along line 5H-5H.

Figure 6 is a perspective view of an embodiment of a cutting apparatus.

Figure 7 is a front side view of the cutting apparatus of Figure 6 as two blades are rotated toward two substrates partially wrapped around an anvil roll.

Figure 8A is a left side view of the cutting apparatus of Figure 7 showing the blade
20 initiating contact with the substrate partially wrapped around the anvil roll.

Figure 8B shows the cutting apparatus of Figure 8A as the blade flexes while being rotated into contact with the substrate partially wrapped around the anvil roll.

Figure 8C shows the cutting apparatus of Figure 8B after the blade is rotated away from the substrate partially wrapped around the anvil roll.

25

DETAILED DESCRIPTION OF THE INVENTION

The following term explanations may be useful in understanding the present disclosure:

“Absorbent article” is used herein to refer to consumer products whose primary function is to absorb and retain soils and wastes. “Diaper” is used herein to refer to an absorbent article generally worn by infants and incontinent persons about the lower torso. The term “disposable”
30 is used herein to describe absorbent articles which generally are not intended to be laundered or otherwise restored or reused as an absorbent article (e.g., they are intended to be discarded after a single use and may also be configured to be recycled, composted or otherwise disposed of in an environmentally compatible manner).

An “elastic,” “elastomer” or “elastomeric” refers to materials exhibiting elastic properties, which include any material that upon application of a force to its relaxed, initial length can stretch or elongate to an elongated length more than 10% greater than its initial length and will substantially recover back to about its initial length upon release of the applied force.

5 As used herein, the term “joined” encompasses configurations whereby an element is directly secured to another element by affixing the element directly to the other element, and configurations whereby an element is indirectly secured to another element by affixing the element to intermediate member(s) which in turn are affixed to the other element.

10 “Longitudinal” means a direction running substantially perpendicular from a waist edge to a longitudinally opposing waist edge of an absorbent article when the article is in a flat out, uncontracted state, or from a waist edge to the bottom of the crotch, i.e. the fold line, in a bi-folded article. Directions within 45 degrees of the longitudinal direction are considered to be “longitudinal.” “Lateral” refers to a direction running from a longitudinally extending side edge to a laterally opposing longitudinally extending side edge of an article and generally at a right
15 angle to the longitudinal direction. Directions within 45 degrees of the lateral direction are considered to be “lateral.”

The term “substrate” is used herein to describe a material which is primarily two-dimensional (i.e. in an XY plane) and whose thickness (in a Z direction) is relatively small (i.e. 1/10 or less) in comparison to its length (in an X direction) and width (in a Y direction).
20 Non-limiting examples of substrates include a web, layer or layers or fibrous materials, nonwovens, films and foils such as polymeric films or metallic foils. These materials may be used alone or may comprise two or more layers laminated together. As such, a web is a substrate.

25 The term “nonwoven” refers herein to a material made from continuous (long) filaments (fibers) and/or discontinuous (short) filaments (fibers) by processes such as spunbonding, meltblowing, carding, and the like. Nonwovens do not have a defined woven or knitted filament pattern.

The term “machine direction” (MD) is used herein to refer to the direction of material flow through a process. In addition, relative placement and movement of material can be
30 described as flowing in the machine direction through a process from upstream in the process to downstream in the process.

The term “cross direction” (CD) is used herein to refer to a direction that is generally perpendicular to the machine direction.

The term “pant” (also referred to as “training pant”, “pre-closed diaper”, “diaper pant”, “pant diaper”, and “pull-on diaper”) refers herein to disposable absorbent articles having a continuous perimeter waist opening and continuous perimeter leg openings designed for infant or adult wearers. A pant can be configured with a continuous or closed waist opening and at least one continuous, closed, leg opening prior to the article being applied to the wearer. A pant can be preformed by various techniques including, but not limited to, joining together portions of the article using any refastenable and/or permanent closure member (e.g., seams, heat bonds, pressure welds, adhesives, cohesive bonds, mechanical fasteners, etc.). A pant can be preformed anywhere along the circumference of the article in the waist region (e.g., side fastened or seamed, front waist fastened or seamed, rear waist fastened or seamed).

“Pre-fastened” refers herein to pant diapers manufactured and provided to consumers in a configuration wherein the front waist region and the back waist region are fastened or connected to each other as packaged, prior to being applied to the wearer. As such pant diapers may have a continuous perimeter waist opening and continuous perimeter leg openings designed for infant or adult wearers. As discussed in more detail below, a diaper pant can be preformed by various techniques including, but not limited to, joining together portions of the diaper using refastenable and/or permanent closure members (e.g., seams, heat bonds, pressure welds, adhesives, cohesive bonds, mechanical fasteners, etc.). In addition, pant diapers can be preformed anywhere along the circumference of the waist region (e.g., side fastened or connected, front waist fastened or connected, rear waist fastened or connected).

The present disclosure relates to methods and apparatuses for assembling absorbent articles, and more particularly, diaper pants, each including a chassis connected with front and back elastic belts. The chassis may include a topsheet, a backsheet, and an absorbent core disposed between the topsheet and the backsheet. The chassis may also have a first end region and an opposing second end region separated from each other by a central region. As discussed in more detail below, opposing end regions of the chassis are connected with regions of the elastic belts where the elasticity of the elastic belts has been removed or deactivated. As discussed in more detail below, an elastic laminate is formed by intermittently bonding elastic strands with a first continuous substrate, defining bonded regions and non-bonded regions intermittently spaced along the machine direction. A second continuous substrate may be cut into discrete lengths or patches intermittently spaced along the machine direction. The discrete lengths of the second substrate may then be bonded with the first continuous substrate and elastic strands in the bonded regions. In some embodiments, the discrete lengths of the second substrate may not extend into the non-bonded regions and/or may not extend entirely across the

non-bonded regions. As such, the elastic strands may be bonded to the first substrate and/or the discrete lengths of the second substrate in the bonded regions. And the elastic strands are not bonded to the first substrate in the non-bonded regions.

In some embodiments, the elastic laminate may then be cut along the machine direction to
5 form a first continuous elastic laminate and a second continuous elastic laminate, each of the first continuous elastic laminate and the second continuous elastic laminate including bonded regions and non-bonded regions. The first continuous elastic laminate and the second elastic laminate are then separated from each other in the cross direction. The elastic strands are then intermittently deactivated by severing the strands in the non-bonded regions of the first
10 continuous elastic laminate and the second elastic laminate. A plurality of chassis may then be bonded between first and second elastic laminates, wherein first and second end regions of each chassis is bonded with non-bonded regions of first and second continuous elastic laminates. In other embodiments, the elastics strands may be intermittently deactivated by severing the strands in the non-bonded regions of the elastic laminate before the elastic laminate is cut into the first
15 and second elastic laminates.

The processes and apparatuses discussed herein may be used to assemble elastic laminates in various types of substrate configurations, some of which may be used in the manufacture of different types of absorbent articles. To help provide additional context to the subsequent discussion of the process embodiments, the following provides a general description
20 of absorbent articles in the form of diapers that include elastic laminates that may be assembled in accordance with the methods and apparatuses disclosed herein. Although the methods and apparatuses herein are discussed below in the context of manufacturing absorbent articles, it is to be appreciated that the assembly methods and apparatuses herein may be configured to manufacture various types of substrates having intermittently spaced elastic and inelastic regions.

Figures 1 and 2A show an example of a diaper pant 100 that may be assembled and
25 folded in accordance with the apparatuses and methods disclosed herein. In particular, Figure 1 shows a perspective view of a diaper pant 100 in a pre-fastened configuration, and Figure 2A shows a plan view of the diaper pant 100 with the portion of the diaper that faces away from a wearer oriented towards the viewer. The diaper pant 100 shown in Figures 1 and 2A includes a
30 chassis 102 and a ring-like elastic belt 104. As discussed below in more detail, a first elastic belt 106 and a second elastic belt 108 are connected together to form the ring-like elastic belt 104.

With continued reference to Figure 2A, the chassis 102 includes a first waist region 116, a second waist region 118, and a crotch region 119 disposed intermediate the first and second waist regions. The first waist region 116 may be configured as a front waist region, and the

second waist region 118 may be configured as back waist region. In some embodiments, the length of each of the front waist region, back waist region, and crotch region may be 1/3 of the length of the absorbent article 100. The diaper 100 may also include a laterally extending front waist edge 120 in the front waist region 116 and a longitudinally opposing and laterally extending back waist edge 122 in the back waist region 118. To provide a frame of reference for the present discussion, the diaper 100 and chassis 102 of Figure 2A is shown with a longitudinal axis 124 and a lateral axis 126. In some embodiments, the longitudinal axis 124 may extend through the front waist edge 120 and through the back waist edge 122. And the lateral axis 126 may extend through a first longitudinal or right side edge 128 and through a midpoint of a second longitudinal or left side edge 130 of the chassis 102.

As shown in Figures 1 and 2A, the diaper pant 100 may include an inner, body facing surface 132, and an outer, garment facing surface 134. The chassis 102 may include a backsheet 136 and a topsheet 138. The chassis 102 may also include an absorbent assembly 140 including an absorbent core 142 that may be disposed between a portion of the topsheet 138 and the backsheet 136. As discussed in more detail below, the diaper 100 may also include other features, such as leg elastics and/or leg cuffs to enhance the fit around the legs of the wearer.

As shown in Figure 2A, the periphery of the chassis 102 may be defined by the first longitudinal side edge 128, a second longitudinal side edge 130; a first laterally extending end edge 144 disposed in the first waist region 116; and a second laterally extending end edge 146 disposed in the second waist region 118. Both side edges 128 and 130 extend longitudinally between the first end edge 144 and the second end edge 146. As shown in Figure 2A, the laterally extending end edges 144 and 146 are located longitudinally inward from the laterally extending front waist edge 120 in the front waist region 116 and the laterally extending back waist edge 122 in the back waist region 118. When the diaper pant 100 is worn on the lower torso of a wearer, the front waist edge 120 and the back waist edge 122 of the diaper pant 100 may encircle a portion of the waist of the wearer. At the same time, the chassis side edges 128 and 130 may encircle at least a portion of the legs of the wearer. And the crotch region 119 may be generally positioned between the legs of the wearer with the absorbent core 142 extending from the front waist region 116 through the crotch region 119 to the back waist region 118.

It is to also be appreciated that a portion or the whole of the diaper 100 may also be made laterally extensible. The additional extensibility may help allow the diaper 100 to conform to the body of a wearer during movement by the wearer. The additional extensibility may also help, for example, allow the user of the diaper 100 including a chassis 102 having a particular size before extension to extend the front waist region 116, the back waist region 118, or both waist regions

of the diaper 100 and/or chassis 102 to provide additional body coverage for wearers of differing size, i.e., to tailor the diaper to an individual wearer. Such extension of the waist region or regions may give the absorbent article a generally hourglass shape, so long as the crotch region is extended to a relatively lesser degree than the waist region or regions, and may impart a tailored appearance to the article when it is worn.

As previously mentioned, the diaper pant 100 may include a backsheet 136. The backsheet 136 may also define the outer surface 134 of the chassis 102. The backsheet 136 may be impervious to fluids (e.g., menses, urine, and/or runny feces) and may be manufactured from a thin plastic film, although other flexible liquid impervious materials may also be used. The backsheet 136 may prevent the exudates absorbed and contained in the absorbent core from wetting articles which contact the diaper 100, such as bedsheets, pajamas and undergarments. The backsheet 136 may also comprise a woven or nonwoven material, polymeric films such as thermoplastic films of polyethylene or polypropylene, and/or a multi-layer or composite materials comprising a film and a nonwoven material (e.g., having an inner film layer and an outer nonwoven layer). The backsheet may also comprise an elastomeric film. An example backsheet 136 may be a polyethylene film having a thickness of from about 0.012 mm (0.5 mils) to about 0.051 mm (2.0 mils). Exemplary polyethylene films are manufactured by Clopay Corporation of Cincinnati, Ohio, under the designation BR-120 and BR-121 and by Tredegar Film Products of Terre Haute, Ind., under the designation XP-39385. The backsheet 136 may also be embossed and/or matte-finished to provide a more clothlike appearance. Further, the backsheet 136 may permit vapors to escape from the absorbent core (i.e., the backsheet is breathable) while still preventing exudates from passing through the backsheet 136. The size of the backsheet 136 may be dictated by the size of the absorbent core 142 and/or particular configuration or size of the diaper 100.

Also described above, the diaper pant 100 may include a topsheet 138. The topsheet 138 may also define all or part of the inner surface 132 of the chassis 102. The topsheet 138 may be compliant, soft feeling, and non-irritating to the wearer's skin. It may be elastically stretchable in one or two directions. Further, the topsheet 138 may be liquid pervious, permitting liquids (e.g., menses, urine, and/or runny feces) to penetrate through its thickness. A topsheet 138 may be manufactured from a wide range of materials such as woven and nonwoven materials; apertured or hydroformed thermoplastic films; apertured nonwovens, porous foams; reticulated foams; reticulated thermoplastic films; and thermoplastic scrims. Woven and nonwoven materials may comprise natural fibers such as wood or cotton fibers; synthetic fibers such as polyester, polypropylene, or polyethylene fibers; or combinations thereof. If the topsheet 138 includes

fibers, the fibers may be spunbond, carded, wet-laid, meltblown, hydroentangled, or otherwise processed as is known in the art.

5 Topsheets 138 may be selected from high loft nonwoven topsheets, apertured film topsheets and apertured nonwoven topsheets. Apertured film topsheets may be pervious to bodily exudates, yet substantially non-absorbent, and have a reduced tendency to allow fluids to pass back through and rewet the wearer's skin. Exemplary apertured films may include those described in U.S. Patent Nos. 5,628,097; 5,916,661; 6,545,197; and 6,107,539.

10 As mentioned above, the diaper pant 100 may also include an absorbent assembly 140 that is joined to the chassis 102. As shown in Figure 2A, the absorbent assembly 140 may have a laterally extending front edge 148 in the front waist region 116 and may have a longitudinally opposing and laterally extending back edge 150 in the back waist region 118. The absorbent assembly may have a longitudinally extending right side edge 152 and may have a laterally opposing and longitudinally extending left side edge 154, both absorbent assembly side edges 152 and 154 may extend longitudinally between the front edge 148 and the back edge 150. The absorbent assembly 140 may additionally include one or more absorbent cores 142 or absorbent core layers. The absorbent core 142 may be at least partially disposed between the topsheet 138 and the backsheet 136 and may be formed in various sizes and shapes that are compatible with the diaper. Exemplary absorbent structures for use as the absorbent core of the present disclosure are described in U.S. Patent Nos. 4,610,678; 4,673,402; 4,888,231; and 4,834,735.

20 Some absorbent core embodiments may comprise fluid storage cores that contain reduced amounts of cellulosic airfelt material. For instance, such cores may comprise less than about 40%, 30%, 20%, 10%, 5%, or even 1% of cellulosic airfelt material. Such a core may comprises primarily absorbent gelling material in amounts of at least about 60%, 70%, 80%, 85%, 90%, 95%, or even about 100%, where the remainder of the core comprises a microfiber glue (if applicable). Such cores, microfiber glues, and absorbent gelling materials are described in U.S. Patent Nos. 5,599,335; 5,562,646; 5,669,894; and 6,790,798 as well as U.S. Patent Publication Nos. 2004/0158212 and 2004/0097895.

30 As previously mentioned, the diaper 100 may also include elasticized leg cuffs 156. It is to be appreciated that the leg cuffs 156 can be and are sometimes also referred to as leg bands, side flaps, barrier cuffs, elastic cuffs or gasketing cuffs. The elasticized leg cuffs 156 may be configured in various ways to help reduce the leakage of body exudates in the leg regions. Example leg cuffs 156 may include those described in U.S. Patent Nos. 3,860,003; 4,909,803; 4,695,278; 4,795,454; and 4,704,115; and U.S. Patent Publication No. 2009/0312730A1.

As mentioned above, diaper pants may be manufactured with a ring-like elastic belt 104 and provided to consumers in a configuration wherein the front waist region 116 and the back waist region 118 are connected to each other as packaged, prior to being applied to the wearer. As such, diaper pants may have a continuous perimeter waist opening 110 and continuous
5 perimeter leg openings 112 such as shown in Figure 1.

As previously mentioned, the ring-like elastic belt 104 is defined by a first elastic belt 106 connected with a second elastic belt 108. As shown in Figure 2A, the first elastic belt 106 defines first and second opposing end regions 106a, 106b and a central region 106c, and the second elastic 108 belt defines first and second opposing end regions 108a, 108b and a central
10 region 108c.

The central region 106c of the first elastic belt is connected with the first waist region 116 of the chassis 102, and the central region 108c of the second elastic belt 108 is connected with the second waist region 118 of the chassis 102. As shown in Figure 1, the first end region 106a of the first elastic belt 106 is connected with the first end region 108a of the second elastic belt
15 108 at first side seam 178, and the second end region 106b of the first elastic belt 106 is connected with the second end region 108b of the second elastic belt 108 at second side seam 180 to define the ring-like elastic belt 104 as well as the waist opening 110 and leg openings 112.

As shown in Figures 2A, 3A, and 3B, the first elastic belt 106 also defines an outer lateral edge 107a, an inner lateral edge 107b, a first longitudinal edge 107c, and a second longitudinal edge 107d. And the second elastic belt 108 defines an outer lateral edge 109a, an inner lateral
20 edge 109b, a first longitudinal edge 109c, and a second longitudinal edge 109d. The outer lateral edges 107a, 109a may also define the front waist edge 120 and the laterally extending back waist edge 122. The first elastic belt and the second elastic belt may also each include an outer, garment facing surface 161 and an inner, wearer facing surface 163.

It is to be appreciated that the first elastic belt 106 and the second elastic belt 108 may
25 comprise the same materials and/or may have the same structure. In some embodiments, the first elastic belt 106 and the second elastic belt may comprise different materials and/or may have different structures. It should also be appreciated that the first elastic belt 106 and the second elastic belt 108 may be constructed from various materials. For example, the first and second
30 belts may be manufactured from materials such as plastic films; apertured plastic films; woven or nonwoven webs of natural materials (e.g., wood or cotton fibers), synthetic fibers (e.g., polyolefins, polyamides, polyester, polyethylene, or polypropylene fibers) or a combination of natural and/or synthetic fibers; or coated woven or nonwoven webs. In some embodiments, the first and second elastic belts include a nonwoven web of synthetic fibers, and may include a

stretchable nonwoven. In other embodiments, the first and second elastic belts include an inner hydrophobic, non-stretchable nonwoven material and an outer hydrophobic, non-stretchable nonwoven material.

It is to be appreciated that the elastic belts 106, 108 may be constructed from various combinations of belt material and elastics. For example, as shown in Figures 2A, 3A, and 3B, the elastic belts may include a first belt material 160, a second belt material 164, and elastics strands 168. The first belt material 160 may define the outer facing surface 161 of the elastic belts 106, 108. As shown in Figures 3A and 3B, a portion of the first belt material 160 may be folded over onto itself to define a waist substrate layer 162 extending along the front and back waist edges 120, 122 of the diaper 100. As such, the waist substrate layer 162 defines a portion of the inner facing surface 163 of the belts 106, 108, and the outer lateral edges 107a, 109a are defined by a fold line 200 between the waist substrate layer 162 and the remainder of the first belt material 160. As such, the waist substrate layer 162 may have a width that extends from the fold line 200 to a distal edge 202. It is to be appreciated that in some embodiments, the waist substrate layer 162 may be defined by a separate strip of belt material bonded with the first belt material 160. In addition, portions of the inner facing surface 163 may be defined by the second belt material 164. For example, first and second panels 165 of the second belt material 164 may be connected with the first belt material 160 in the first end region 106a and the second end region 106b, respectively, of the first elastic belt 106. Similarly, first and second panels 165 of the second belt material 164 may be connected with the first belt material 160 in the first end region 108a and the second end region 108b, respectively, of the second elastic belt 108.

It is to be appreciated that the panels 165 may have various shapes and sizes. For example, as shown in Figures 2A, 3A, and 3B, the panels 165 may have square or rectangular shapes defined by a first laterally extending edge 204, a second laterally extending edge 206, a first longitudinally extending edge 208, and a second longitudinally extending edge 210. It is also to be appreciated that the panels 165 may be positioned in various locations on the elastic belts 106, 108. For example, the first lateral edges 204 of the panels 165 may be positioned inward from the outer lateral edges 107a, 109a of the first and second elastic belts 106, 108. In some embodiments, such as shown in Figures 3A and 3B, the first lateral edges of the panels 165 may be positioned longitudinally outward of the distal edge 202 of the waist substrate layer 162. As such, the waist substrate layer 162 may overlap portions of the panels 165 adjacent the first longitudinal edges 202. In addition, the second lateral edges 206 of the panels 165 may be aligned with and define portions of the inner lateral edges 107b, 109b of the first and second elastic belts 106, 108. The first longitudinal edges 208 of the panels 165 may also be aligned

with and define portions of the longitudinal edges 107c, 107d, 109c, 109d of the first and second elastic belts 106, 108. Further, depending on the sizes of the panels 165 relative to the belts 106, 108, the second longitudinally extending edges 210 of the panels may be located in the end regions 106a, 106b or central region 106c of the first belt 106 and/or the end regions 108a, 108b
5 or the central region 108c of the second belt 108.

As previously mentioned, the first and second elastic belts 106, 108 may also each include belt elastic material interposed between the outer layer 162 and the inner layer 164. The belt elastic material may include one or more elastic elements such as strands, ribbons, or panels extending along the lengths of the elastic belts. As shown in Figures 2A, 3A, and 3B, the belt
10 elastic material may include a plurality of elastic strands 168 which may be referred to herein as outer, waist elastics 170 and inner, waist elastics 172. The outer, waist elastics 170 may be bonded between the waist substrate layer 162 and the correspondingly facing portion of the first belt material 160. In addition, the inner, waist elastics 172 may be bonded between the first belt material 160 and the panels 165 of the second belt material 164.

As shown in Figure 2A, the outer, waist elastics 170 may extend continuously laterally
15 between the first and second opposing end regions 106a, 106b and across the central region 106c of the first elastic belt 106 and between the first and second opposing end regions 108a, 108b and across the central region 108c of the second elastic belt 108. In some embodiments, some elastic strands 168 may be configured with discontinuities in areas. For example, as shown in Figure
20 2A, the inner, waist elastics 172 extend intermittently along the first and second elastic belts 106, 108. More particularly, the inner, waist elastics 172 extend along the first and second opposing end regions 106a, 106b and partially across the central region 106c of the first elastic belt 106. The inner, waist elastics 172 also extend along the first and second opposing end regions 108a, 108b and partially across the central region 108c of the second elastic belt 108. As such, the
25 inner, waist elastics 172 do not extend across the entirety of the central regions 106c, 108c of the first and second elastic belts 106, 108. Thus, some elastic strands 168 may not extend continuously through regions of the first and second elastic belts 106, 108 where the first and second elastic belts 106, 108 overlap the absorbent assembly 140. In some embodiments, some elastic strands 168 may partially extend into regions of the first and second elastic belts 106, 108
30 where the first and second elastic belts 106, 108 overlap the absorbent assembly 140. In some embodiments, some elastic strands 168 may not extend into any region of the first and second elastic belts 106, 108 where the first and second elastic belts 106, 108 overlap the absorbent assembly 140. It is to be appreciated that the first and/or second elastic belts 106, 108 may be

configured with various configurations of discontinuities in the outer, waist elastics 170 and/or the inner, waist elastic elastics 172.

In some embodiments, the elastic strands 168 may be disposed at a constant interval in the longitudinal direction. In other embodiments, the elastic strands 168 may be disposed at
5 different intervals in the longitudinal direction. As discussed in more detail below, the belt elastic strands 168, in a stretched condition, may be interposed and joined between the uncontracted outer layer and the uncontracted inner layer. When the belt elastic material is relaxed, the belt elastic material returns to an unstretched condition and contracts the outer layer and the inner layer in the regions in which the elastics are joined to the belt layers. The belt
10 elastic material may provide a desired variation of contraction force in the area of the ring-like elastic belt.

It is to be appreciated that the chassis 102 and elastic belts 106, 108 may be configured in different ways other than as depicted in Figure 2A. For example, Figure 2B shows a plan view of a diaper pant 100 having the same components as described above with reference to Figure 2A,
15 except the first laterally extending end edge 144 of the chassis 102 is aligned along and coincides with the outer lateral edge 107a of the first elastic belt 106, and the second laterally extending end edge 146 is aligned along and coincides with the outer lateral edge 109a of the second belt 108.

As previously mentioned, the apparatuses and methods according to the present
20 disclosure may be utilized to assemble various components of pre-fastened pant diapers 100. For example, Figure 4 shows a schematic view of a converting apparatus 300 adapted to manufacture pant diapers 100. The method of operation of the converting apparatus 300 may be described with reference to the various components of pant diapers 100 described above and shown in Figures 1 and 2A. Although the following methods are provided in the context of the diaper 100
25 shown in Figures 1 and 2A, it is to be appreciated that various embodiments of diapers and associated components, such as for example leg cuffs and waist bands, can be manufactured according the methods disclosed herein, such as for example, the absorbent articles disclosed in U.S. Patent Nos. 7,569,039 and 5,745,922; U.S. Patent Publication Nos. 2005/0107764A1,, 2012/0061016A1, and 2012/0061015A1; and the U.S. Patent Application entitled "Methods and
30 Apparatuses for Making Leg Cuffs for Absorbent Articles," filed March 30, 2012, also identified by Attorney Docket Number 12395, which are all hereby incorporated by reference herein.

As described in more detail below, the converting apparatus 300 shown in Figure 4 operates to advance a composite chassis web wherein the longitudinal axis of the chassis in the chassis web are disposed parallel to the machine direction. The chassis web is then cut to form

discrete chassis 102 that are also turned 90 degrees along a machine direction MD such that the lateral axis of each chassis 102 is parallel with the machine direction, and wherein the chassis 102 are spaced apart from each other along the machine direction. Opposing waist regions 116, 118 of the spaced apart chassis 102 are then connected with continuous lengths of advancing first and second elastic belt substrates 406, 408. The chassis 102 are then folded along the lateral axis to bring the first and second elastic belt substrates 406, 408 into a facing relationship, and the first and second elastic belt substrates are connected together along intermittently spaced seams 336. And the elastic belt substrates 406, 408 are cut along the seams 336 to create discrete
5 diapers 100, such as shown in Figure 1.

As shown in Figures 4 and 5A1, continuous lengths of outer layer first belt material 160, inner layer discrete lengths 165a of the second belt material 164, outer elastic strands 168, 170, and inner elastic strands 168, 172 are advanced in a machine direction MD and combined at nip rolls 500, 501 to form a continuous length of belt material 402. As shown in Figure 4, a continuous length of second belt material 164 advances in a machine direction MD to anvil roll
10 500. At anvil roll 500, knife roll 502 cuts the continuous length of second belt material 164 into discrete lengths or patches 165a of second belt material. As shown in Figures 4 and 5A1, the discrete lengths or patches 165a of second belt material 164 are spaced from each other in the machine direction by anvil roll 500 before being combined with the first belt material 160 and elastics 168 at the nip between rolls 500, 501. An example operation for achieving the spacing
15 between discrete components, such as patches 165a, is disclosed in U.S. Patent No. 5,702,551. It is to be appreciated that other types of operations and equipment may be used to cut and space the discrete lengths 165a of second belt material 164, such as disclosed in U.S. Patent No. 6,811,019. It is to be appreciated that the discrete lengths or patches 165a of second belt material 164 may have various shapes and sizes. For example, the patches may have rectangular shapes
20 defined by a leading edge 208a and a trailing edge 208b both connected with and separated by edges 204a, 204b. As discussed in more detail below, the discrete lengths or patches 165a of the second belt material may be cut to form the panels 165 described above with reference to Figures 2A, 3A, and 3B.
25

With continued reference to Figures 4 and 5A1, before entering the nip between rolls 500,
30 501, the outer elastic strands 170 and inner elastic strands 172 are stretched in the machine direction MD. In addition, adhesive 504 may be applied to the elastic strands 170, 172 as well as either one or both of the continuous lengths of outer layer belt material 160 and the discrete lengths 165a of inner layer belt material 164 before advancing between nip rolls 500, 501. Further, adhesive 504 may be applied intermittently along the lengths of the inner elastic strands

172 and/or intermittently along the length of the continuous length of outer layer belt material 160 before advancing between nip rolls 500, 501.

As shown in Figures 4 and 5A1, the inner elastic strands 172 are intermittently bonded to either one or both of the continuous length of outer layer belt material 162 and the patches 165a of inner layer belt material 164 along the machine direction MD. More particularly, as shown in Figure 5A1-5A3, the belt material 402 may include non-bonded regions 403 intermittently spaced between bonded regions 405 along the machine direction MD. Thus, the inner elastic strands 172 are not bonded to the outer layer belt material 160 in the non-bonded regions 403. And the inner elastic strands 172 are bonded to the outer layer belt material 160 and/or patches 165a of inner layer belt material 164 in the bonded regions 405. For the purposes of clarity, dashed lines 401 are shown in Figures 5A-5C2 to represent example boundaries between the non-bonded regions 403 and the bonded regions 405. It is to be appreciated that such boundaries between the non-bonded regions 403 and the bonded regions 405 can also be curved, angled, and/or straight. In some embodiments, the discrete lengths 165a of the second belt material 164 may not extend into the non-bonded regions 403 and/or may not extend entirely across the non-bonded regions 403. In some embodiments, the boundaries between the non-bonded regions 403 and the bonded regions 405 may be defined by leading and trailing edges 208a, 208b of the discrete lengths 165a of second belt material 164.

With continued reference to Figures 4 and 5A1, the outer elastic strands 170 may be continuously bonded with the continuous length of belt material 160 at rolls 500, 501. As shown in Figure 4, the first belt material 160 includes a first surface 161a and an opposing second surface 161b. And as shown in Figure 5A1, along the cross direction CD, the belt material 160 includes opposing longitudinal edges 160a, 160b and laterally opposed edge regions 166a, 166b separated by a central region 166c. Thus, the outer elastic strands 170 may be continuously bonded with the opposing edge regions 166a, 166b of the first surface 161a of the continuous length of belt material 160 at rolls 500, 501. As shown in Figures 4 and 5A2, the combined elastics 170 and the belt material 160 advance from the rolls 500, 501 to a folding apparatus 503 adapted to fold the opposing edge regions 166a, 166b onto themselves. In particular, the folding apparatus 503 folds a portion of the first surface 161a of the edge region 166a onto another portion of the first surface 161a of the edge region 166a, with the elastics 170 bonded between the folded portions. The folding apparatus also folds the first surface 161a of the edge region 166b onto another portion of the first surface 161a of the edge region 166b, with the elastics 170 bonded between the folded portions. As such, fold lines 200a, 200b define the opposing longitudinal edges of belt material 402. And the outer elastics 170 are sandwiched between first

surfaces 161a of the opposing edge regions 166a, 166b, such as shown in Figures 5A2 and 5A3. Instead of folding opposing edge regions 166a, 166b, in some embodiments the outer elastics 170 may be bonded between separate strips 165a of belt material 164 and the first belt material 160. As shown in Figures 5A2 and 5A3, the edge regions 166a, 166b may be folded such that the edges 160a, 160b may overlap the edges 204a, 204b of the discrete lengths 165a of second belt material 164. It is to be appreciated that the folding apparatus 503 may be configured in various ways, such as for example, a folding board and/or twisted conveyors.

As shown in Figure 4, from the folding apparatus 503, the continuous length of belt material 402 advances in the machine direction MD to a cutter 506 that cuts the belt material 402 into two continuous belt substrates, referred to as a first belt substrate 406 and a second belt substrate 408. The cutter 506 may be configured in various ways. For example, in some embodiments the cutter 506 may be a slitter or a die cutter that separates the belt material into two continuous belt substrates with either a straight line cut and/or a curved line cut. The cutter 506 may also be configured as a perforator that perforates the belt material with a line of weakness and wherein the belt material is separated along the line of weakness in a later step. From the cutter 506, the first and second belt substrates 406, 408 advance through a diverter 508 that separates the first and second belt substrates from each other in the cross direction CD, such as shown in Figure 5B. The elastic strands 170, 172, and thus, the continuous length of first and second belt substrates 406, 408 are maintained in a stretched condition while advancing along the machine direction MD.

It is to be appreciated that the diverter 508 may be configured in various ways. For example, in some embodiments, the diverter 508 may include turn bars angled at 45 degrees or some other angle with respect to the machine direction. In some embodiments, the diverter may include cambered rollers. Other embodiments may include diverters in the form of a pivot table, such as, for example, the FIFE-500 Web Guiding System, by Maxcess-FIFE Corporation. The diverter may also include instrumentation and web edge control features that allow for precise active control of the substrate positions.

With continued reference to Figures 4, 5B, 5B1, and 5B2, the first and second belt substrates 406, 408 advance from the diverter 508 to a cutting unit 510. The cutting unit 510 then intermittently deactivates the elastics 168 in the first and second belt substrates 406, 408. More particularly, the cutting unit 510 may sever, cut, and/or break the inner elastics 168, 172 in the non-bonded regions 403 of the first and second belt substrates 406, 408. As shown in Figures 5C, 5C1, and 5C2, severed ends 404 of the inner elastics 172 retract or snap back to the bonded regions 405 of the first and second belt substrates 406, 408. In some embodiments such as

shown in Figures 5C1 and 5C2, the cutting unit 510 may be configured to sever only the elastics 168, 172 in the non-bonded regions 403 of the first and/or second belt substrates 406, 408 without cutting through the outer layer belt material 160. The cutting unit 510 may be configured to cut the elastics 168, 172 in the non-bonded regions 403 of the first and second belt substrates 406, 408 while also cutting through the outer layer belt material 160. For example, Figures 5C1A and 5C2A show a configuration where the cutting unit 510 cuts slits 413 through the outer layer belt material 160 while cutting the elastics 168, 172 in the non-bonded regions 403 of the first and second belt substrates 406, 408.

As previously discussed, the inner elastic strands 172 are not bonded to the outer layer belt material 160 in the non-bonded regions 403. However, it is to be appreciated that the non-bonded regions 403 and bonded regions 405 may be configured with various adhesive applications. For example, Figure 5B3 shows a detailed view of a belt substrate 408 with the folded edge regions 166a, 166b of the belt material 160 and the patches 165a of inner layer belt material 164 cut-away to illustrate an embodiment of adhesive application in the bonded regions 405. More particularly, Figure 5B3 shows an example adhesive application configuration wherein adhesive 504A has been applied to the belt materials 160, 164 and/or elastics 168, 172 in the bonded regions 405, and wherein adhesive has not been applied either the belt material 160 or the elastics 168, 172, in the non-bonded regions 403. As such, adhesive 504A may be intermittently applied along the machine direction MD in the bonded regions 405.

With continued reference to Figure 5B3, adhesive 504A may be applied in strips along the elastics 168, 172 extending the machine direction MD in the bonded regions 405. As such, the adhesive 504A bonds the belt material 160, the patches 165a of belt material 164, and the elastics 168, 172 together in the bonded regions 405. Figure 5C3 shows a detailed view of the belt substrate 408 from Figure 5B3 with the with the folded edge regions 166a, 166b of the belt material 160 and the patches 165a of inner layer belt material 164 cut-away to illustrate the elastics 168, 172 after having been cut in the non-bonded regions 403, wherein the severed ends 404 of the elastics 168, 172 have retracted or snapped back to the bonded regions 405.

It is to be appreciated that various configurations of cutting units 510 can be used with the apparatuses and methods herein. Such cutting unit configurations may include features of the cutting knives/units disclosed, for example, in U.S. Patent Nos. 5,393,360; 7,708,849; 7,861,756; 7,777,094; U.S. Patent Application No. 13/434,912, filed on March 30, 2012, further identified by Attorney Docket Number 12394; and U.S. Patent Application No. 61/617,713, filed on March 30, 2012, further identified by Attorney Docket Number AA833FP-AF, which are all incorporated by reference herein. As such, the cutting units may be configured with die knife,

flexible blade, and/or compression roll features, and may also include additional features to control knife-anvil gaps and/or force.

Figures 6 and 7 show an example embodiment of a cutting unit 510 including a cutting roll 600 and an anvil roll 602. The cutting roll 600 is adapted to rotate around an axis of rotation 604 and defines an outer circumferential surface 606. And the anvil roll 602 is adapted to rotate around an axis of rotation 608 and defines an outer circumferential surface 610. The cutting roll 600 is adjacent to the anvil roll 602 and create a nip 603 defined by a minimum distance, D , between the outer circumferential surface 606 of the cutting roll 602 and the outer circumferential surface 610 of the anvil roll 602. As shown in Figures 6 and 7, the cutting roll 600 may also include one or more blades 612. Each blade 612 may have a proximal end portion 614 extending in a cross direction (CD) a length, L , along the outer circumferential surface 606 of the cutting roll 600. The blades 612 may define a dimension, $H1$, extending from the proximal end portion 614 to a distal edge 616. In addition, from the proximal end portion 614, the blades may extend radially outward from the outer circumferential surface 606 of the cutting roll 600 to the distal edge 616 by a distance, H . It is to be appreciated that the blades 612 may extend radially outward from the outer circumferential surface 606 to define an angle of 90 degrees or less, such as about 45 degrees, between the blade 612 and a tangential plane intersecting the proximal end portion 614 on the outer circumferential surface 606. As such, in some embodiments, $H1$ may be equal to H , and in some embodiments, $H1$ may be greater than H . As shown in Figures 6 and 7, the blades 612 may define a rectangular shape having a first surface 618 and an opposing second surface 620 separated by a thickness, t . The blades 612 may have a small thickness, t , relative to the distance, $H1$, such that blades 612 are flexible or bendable.

As shown in Figures 6-8C, the cutting unit 510 may be arranged such that the first and second belt substrates 406, 408 advance in a machine direction MD to partially wrap around the outer circumferential surface 610 of the anvil roll 602. As the anvil roll 602 and the cutting roll 600 rotate, portions of the first surfaces 618 and the distal edges 616 of the blades 612 are moved into contact with the first and second belt substrates 406, 408, such as shown in Figure 8A. As shown in Figures 8A-8C, the distance, H , of each blade 612 is greater than the distance, D , between the cutting roll 600 and the anvil roll 602. Thus, with reference to Figure 8B, as the blades 612 rotate through the nip 603 between the cutting roll 600 and the anvil roll 602, the blades 612 flex or bend inward along the second surface 620. As such, portions of the first surfaces 618 and/or the distal edges 616 of the blades 612 exert pressure on the first and second belt substrates 406, 408 to cut the elastics 168, 172 in the non-bonded regions 403. Referring now to Figure 8C, as the cutting roll 600 continues to rotate, the blades 612 move away from the

nip 603 and straighten back out along the distance, H1, thus returning to the original blade shapes before entering the nip 603.

It is to be appreciated that the belt substrate materials may be arranged in various ways on the cutting unit 510. For example, as shown in Figures 6-8C, the front belt substrate material 406 and the back belt substrate material 408 may advance in the machine direction MD to partially wrap around the rotating anvil roll 602 such that the outer layer belt material 162 of the front belt substrate material 406 and the back belt substrate material 408 are in contact with the outer circumferential surface 610 of the anvil roll 602. As such, the blades 612 of the rotating cutting roll 600 contact the inner layer belt material 164 of the front belt substrate material 406 and the back belt substrate material 408 while advancing through the nip 603. It is to be appreciated that the front and back belt substrates 406, 408 may be arranged such that the belt material 160 is in contact with the outer circumferential surface 610 of the anvil roll 602. For example, in some embodiments, the front belt substrate material 406 and the back belt substrate material 408 may be arranged to partially wrap around the rotating anvil roll 602 such that the outer layer of belt material 160 of the front belt substrate material 406 and the back belt substrate material 408 are in contact with the outer circumferential surface 610 of the anvil roll 602. As discussed above, the cutting unit 510 shown in Figures 6-8C may be configured to sever only the elastics 168, 172 in the non-bonded regions 403 of the first and/or second belt substrates 406, 408 without cutting through the outer layer belt material 160. In other configurations, the cutting unit 510 may be configured to cut the elastics 168, 172 in the non-bonded regions 403 of the first and second belt substrates 406, 408 while also cutting through the outer layer belt material 160.

It is to be appreciated that the cutting unit 510 may be configured with various quantities of blades having various shapes and orientations. For example, the cutting unit 510 shown in Figures 6-8C includes four blades 612a, 612b, 612c, 612d. The first and second blades 612a, 612b may be located 180 degrees apart from the third and fourth blades 612c, 612d on the outer circumferential surface 606 of the cutting roll 600. It is to be appreciated that the cutting roll may also be configured with various numbers of blades arranged circumferentially along the outer circumferential surface 606 of the cutting roll 600. The proximal end portions 614 of the first blade 612a and the second blade 612b may also be aligned with each other and with the axis of rotation 604 so as to extend in a straight line in the cross direction (CD) perpendicular to the machine direction (MD). Similarly, proximal end portions 614 of the third blade 612c and the fourth blade 612d may be aligned with each other and with the axis of rotation 604 so as to extend in a straight line in the cross direction (CD) perpendicular to the machine direction (MD). In addition, the first blade 612a and the second blade 612b, as well as the third and fourth blades

612c, 612d, may define different lengths, L, and may be separated from each other by various distances in the cross direction CD. For example, the lengths, L, of the blades 612 are configured such so as to engage portions of the first and second belt substrates 406, 408 so as to cut the elastics 168, 172 without cutting elastics 168, 170. In addition, the blades 612 may be configured to cut the elastics 168, 172 simultaneously in the CD direction along in a substantially straight line. It is also to be appreciated that the cutting roll 600 may be configured with more than or less than two blades 612 aligned along the CD direction of outer circumferential surface 606 of the cutting roll 600. For example, in some embodiments, instead of having the first blade 612a and the second blade 612b, the cutting roll 600 may be configured with a single blade 612 extending along the CD direction for a length, L, on the outer circumferential surface 606. It is also to be appreciated that the cutting roll 600 may be configured to cut the elastics 168 more than once in a zone or region. For example, the cutting roll 600 may be configured to cut the elastics 168, 172 more than once in the non-bonded region 403. It should also be appreciated that the cutting operation may be linked with a vacuum operation that enables removal of the cut portions of the elastic from the belt web.

Referring back to Figure 4, from the cutting unit 510, the first and second belt substrates 406, 408 advance in the machine direction MD and are combined with discrete chassis 102. As shown in Figures 4 and 5D, a continuous length of chassis assemblies 302 are advanced in a machine direction MD to a carrier apparatus 512 and cut into discrete chassis 102 with knife roll 514. As shown in Figure 5D, the continuous length of chassis assemblies 302 may include absorbent assemblies 140 sandwiched between topsheet material 138 and backsheet material 136, leg elastics, barrier leg cuffs and the like. A portion of the chassis assembly is cut-away to show a portion of the topsheet material 138 and an absorbent assembly 140.

After the continuous web of absorbent chassis 102 are cut by the knife roll 514 to form discrete chassis, the carrier apparatus 512 rotates and advances the discrete chassis 102 in the machine direction MD in the orientation shown in Figure 5E1, wherein the longitudinal axis 124 of the chassis 102 is rotated from generally parallel with the machine direction MD to a position that is generally perpendicular to the machine direction. While the chassis 102 shown in Figure 5E1 is shown with the second laterally extending end edge 146 as a leading edge and the first laterally extending end edge 144 as the trailing edge, it is to be appreciated that in other embodiments, the chassis 102 may be advanced in other orientations. For example, the chassis may be oriented such that the second laterally extending end edge 146 is a trailing edge and the first laterally extending end edge 144 is a leading edge. The carrier apparatus 308 also rotates while at the same time changing the orientation of the advancing chassis 102. The carrier

apparatus 308 may also change the speed at which the chassis 102 advances in the machine direction MD. It is to be appreciated that various forms of carrier apparatuses may be used with the methods herein, such as for example, the carrier apparatuses disclosed in U.S. Patent No. 7,587,966. Figure 5E2 shows an orientation of the chassis 102 on the carrier apparatus 308 while
5 advancing in the machine direction that is different from that depicted in Figure 5E1. More particularly, Figure 5E2 shows the chassis 102 with the lateral axis 126 of the chassis 102 generally parallel with the machine direction MD, and wherein the first longitudinal side edge 128 is the leading edge and the second longitudinal side edge 130 is the trailing edge.

As discussed below with reference to Figures 4, 5F, 5G, and 5H, the chassis 102 are
10 transferred from the carrier apparatus 512 and combined with advancing, continuous lengths of belt substrates 406, 408, which are subsequently cut to form first and second elastic belts 106, 108 on diapers 100.

With reference to Figures 4 and 5F, the chassis 102 are transferred from the carrier apparatus 512 to a nip 516 between the carrier apparatus 512 and a roll 518 where the chassis 102
15 are combined with continuous lengths of advancing front belt substrate material 406 and back belt substrate material 408. The front belt substrate material 406 and the back belt substrate material 408 each define a wearer facing surface 312 and an opposing garment facing surface 314. The wearer facing surface 312 of the first belt substrate 406 may be combined with the garment facing surface 134 of the chassis 102 along the first waist region 116, and the wearer
20 facing surface 312 of the second belt substrate 408 may be combined with the garment facing surface 134 of the chassis 102 along the second waist region 118. As shown in Figure 4, adhesive 520 may be intermittently applied to the wearer facing surface 312 of the first and second belt substrates 406, 408 before combining with the discrete chassis 102 at the nip 516 between roll 518 and the carrier apparatus 512. In some embodiments, the chassis 102 may be
25 joined to the first and second belts in various different ways, such as for example, thermal bonds, pressure bonds, ultrasonic bonds, adhesives and combinations thereof.

In some embodiments, such as shown in Figures 4, 5C, 5C1, 5C2, and 5F, adhesive 520 may be intermittently applied to portions of the body facing surface 312 at the non-bonded regions 403 of the first belt substrate 406 and/or the second belt substrate 408. And adhesive
30 may not be applied to portions of the body facing surface 312 at the bonded regions 405 of the first belt substrate 406 and/or the second belt substrate 408. As such, the garment facing surface 134 of the chassis 102 may be combined in an overlapping relationship with the non-bonded regions 403 of the first belt substrate 406 and/or the second belt substrate 408. As such, in some embodiments, the non-bond regions 403 of the first and second belt substrates 406, 408 may

correspond with and/or define the central regions 106c, 108c of the first and second elastic belts 106, 108 discussed above with reference to Figures 1-2B. In addition, the bonded regions 405 may correspond with and/or define the opposing end regions 106a, 106b, 108a, 108b of the of the first and second elastic belts 106, 108 discussed above with reference to Figures 1-2B.

5 It is to be appreciated that in embodiments of the process configurations described herein, end portions of the chassis 102 are positioned in an overlapping relationship with the non-bonded regions 403 of the first belt substrate 406 and/or the second belt substrate 408 having a single substrate layer, as opposed to two or more substrate layers. As such, in some embodiments, graphics may be printed on an end portion of the chassis 102, wherein the graphics may be
10 visible through the single substrate layer of a belt substrate. It is to be appreciated that a single belt substrate layer may have a relatively lower basis weight than multiple belt substrate layers and as a result, may have a relatively lower opacity. When graphics are printed on a portion of the chassis covered by such a lower basis weight, lower opacity region, the graphics may be visible with relatively less distortion and/or masking than if the graphics were covered by a
15 multi-layer, higher basis weight, higher opacity region.

With reference to Figures 4 and 5F, a continuous length of absorbent articles 400 are defined by multiple discrete chassis 102 spaced from each other along the machine direction MD and connected with each other by the second belt substrate 408 and the first belt substrate 406. As shown in Figure 4, the continuous length of absorbent articles 400 advances from the nip 516
20 to a folding apparatus 522. At the folding apparatus 522, each chassis 102 is folded in the cross direction CD along a lateral axis 126 to place the first waist region 116, and specifically, the inner, body facing surface 132 into a facing, surface to surface orientation with the inner, body surface 132 of the second waist region 118. The folding of the chassis also positions the wearer facing surface 312 of the second belt substrate 408 extending between each chassis 102 in a
25 facing relationship with the wearer facing surface 312 of the first belt substrate 406 extending between each chassis 102. As shown in Figures 4, 5F, and 5G, the folded discrete chassis 102 connected with the first and second belt substrates 406, 408 are advanced from the folding apparatus 522 to a bonder 524. The bonder 524 operates to bond a portion of the second belt substrate 408 extending between each chassis 102 with a portion of the first belt substrate 406
30 extending between each chassis 102, thus creating discrete bond regions 336. It is to be appreciated that various types of bonder apparatuses and methods can be used to bond the second belt substrate material 408 with the first belt substrate material 406, such as for example disclosed in U.S. Patent Nos. 6,248,195; 6,546,987; and 7,383,865, as well as U.S. Patent Publication No. 2012/0021186A1, which are incorporated by reference herein.

As shown in Figures 4 and 5H, a continuous length of absorbent articles are advanced from the bonder 524 to a knife roll 526 where the discrete bond regions 336 are cut along the cross direction to create a first side seam 178 on an absorbent article 100 and a second side seam 180 on a subsequently advancing absorbent article. As such, in some embodiments, the knife roll
5 526 cuts the patches 165a of the first and second belt substrates 406, 408 to define the panels 165 of the second belt material 164 in the end regions 106a, 106b, 108a, 108b of the first and second elastic belts 106, 108 discussed above with reference to Figures 2A, 3A, and 3B.

The dimensions and values disclosed herein are not to be understood as being strictly limited to the exact numerical values recited. Instead, unless otherwise specified, each such
10 dimension is intended to mean both the recited value and a functionally equivalent range surrounding that value. For example, a dimension disclosed as “40 mm” is intended to mean “about 40 mm.”

Every document cited herein, including any cross referenced or related patent or application, is hereby incorporated herein by reference in its entirety unless expressly excluded
15 or otherwise limited. The citation of any document is not an admission that it is prior art with respect to any invention disclosed or claimed herein or that it alone, or in any combination with any other reference or references, teaches, suggests or discloses any such invention. Further, to the extent that any meaning or definition of a term in this document conflicts with any meaning or definition of the same term in a document incorporated by reference, the meaning or definition
20 assigned to that term in this document shall govern.

While particular embodiments of the present invention have been illustrated and described, it would be obvious to those skilled in the art that various other changes and modifications can be made without departing from the spirit and scope of the invention. It is therefore intended to cover in the appended claims all such changes and modifications that are
25 within the scope of this invention.

CLAIMS

What is claimed is:

1. A method for assembling disposable pant diapers (100), each pant diaper comprising a chassis (102) having a first end region (116) and an opposing second end region (118) separated from each other by a central region (119), and having a longitudinal axis (124) and a lateral axis (126), the chassis (102) comprising: a topsheet (138), a backsheet (136), and an absorbent core (140) disposed between the topsheet (138) and the backsheet (136), the method comprising the steps of:

advancing a first continuous substrate (160) having a first surface and an opposing second surface in a machine direction, and defining a width in a cross direction;

advancing a second continuous substrate (164) having a first surface and an opposing second surface in a machine direction, and defining a width in a cross direction;

cutting the second continuous substrate (164) into discrete lengths (165a) of second substrate material;

advancing elastic strands (168) in the machine direction in a stretched state;

intermittently bonding the elastic strands (168) in the stretched state between the first surface of the first substrate (160) and the first surfaces of the discrete lengths (165a) of second substrate material (164) to form an elastic laminate (402), the elastic laminate including bonded regions (405) and non-bonded regions (403) intermittently spaced along the machine direction, wherein the elastic strands (168) are bonded to the first surface of the first substrate (160) and the first surfaces of the discrete lengths (165a) of second substrate material (164) in the bonded regions (405), and wherein the elastic strands (168) are not bonded to the first substrate (160) in the non-bonded regions (403); and

bonding the first end regions (116) of each chassis (102) with non-bonded regions (403) of the elastic laminate (402).

2. The method of claim 1, further comprising the step of: cutting the elastic laminate (402) along the machine direction to form a first continuous elastic laminate (406) and a second continuous elastic laminate (408), each of the first continuous elastic laminate (406) and the second continuous elastic laminate (408) including bonded regions (405) and non-bonded regions (403).

3. The method of claim 2, further comprising the step of: separating the first continuous elastic laminate (406) and the second elastic laminate (408) in the cross direction.

4. The method of claim 2, further comprising the step of: bonding the second end regions (118) of each chassis (102) with non-bonded regions (403) of the second continuous elastic laminate (408).

5. The method according to any of the preceding claims, further comprising the steps of:
advancing a third continuous substrate (302) in the machine direction;
cutting the third continuous substrate (302) into discrete chassis (102), wherein each chassis (102) advances such that the longitudinal axis (124) is parallel with the machine direction; and
turning each chassis (102) such that the lateral axis (126) is parallel with the machine direction.

6. The method of claim 5, further comprising the steps of:
folding each chassis (102) along the lateral axis to position the first continuous elastic laminate (406) into a facing relationship with the second continuous elastic laminate (408);
bonding the first continuous elastic laminate (406) with the second continuous elastic laminate (408) at discrete bond regions (336); and
cutting the first and second continuous elastic laminates (406, 408) to form pant diaper side seams (178, 180).

7. The method according to any of the preceding claims, wherein the first end region (116) is a front waist region.

8. The method according to any of the preceding claims, wherein the second end region (118) is a back waist region.

9. The method according to any of the preceding claims, further comprising the step of: severing elastic strands (168) in the non-bonded regions (403) of the elastic laminate.

10. The method of claim 9, wherein the step of severing the elastic strands further comprises cutting the elastic strands (168) and the first continuous substrate (160) in the non-bonded regions (403).

11. The method of claim 9, wherein the step of severing the elastic strands (168) further comprises cutting the elastic strands (168) in the non-bonded regions (403) without cutting the first continuous substrate (160).

12. The method according to any of the preceding claims, wherein the step of severing the elastic strands (168) further comprises applying pressure to the first substrate layer (160) and the elastic strands (168) with a distal edge (616) of a blade (612).

13. The method according to any of the preceding claims, further comprising the step of advancing the first elastic laminate (406) in the machine direction (MD) through a nip (603) defined between a cutting roll (600) and an anvil roll (602), the cutting roll (600) rotating around a first axis of rotation (604) and the anvil roll (602) rotating around a second axis of rotation (608), wherein the cutting roll (600) includes an outer circumferential surface (606), and wherein the anvil roll (602) includes an outer circumferential surface (610) defining a minimum distance D between the outer circumferential surface (606) of the cutting roll (600) and the outer circumferential surface (610), wherein the cutting roll (600) includes a blade (612) having a distal edge (616) defining a maximum distance H between the distal edge (616) and the outer circumferential surface (606) of the cutting roll (600), and wherein the H is greater than D .

14. The method of claim 13, further comprising the step of: bending the blade (612).

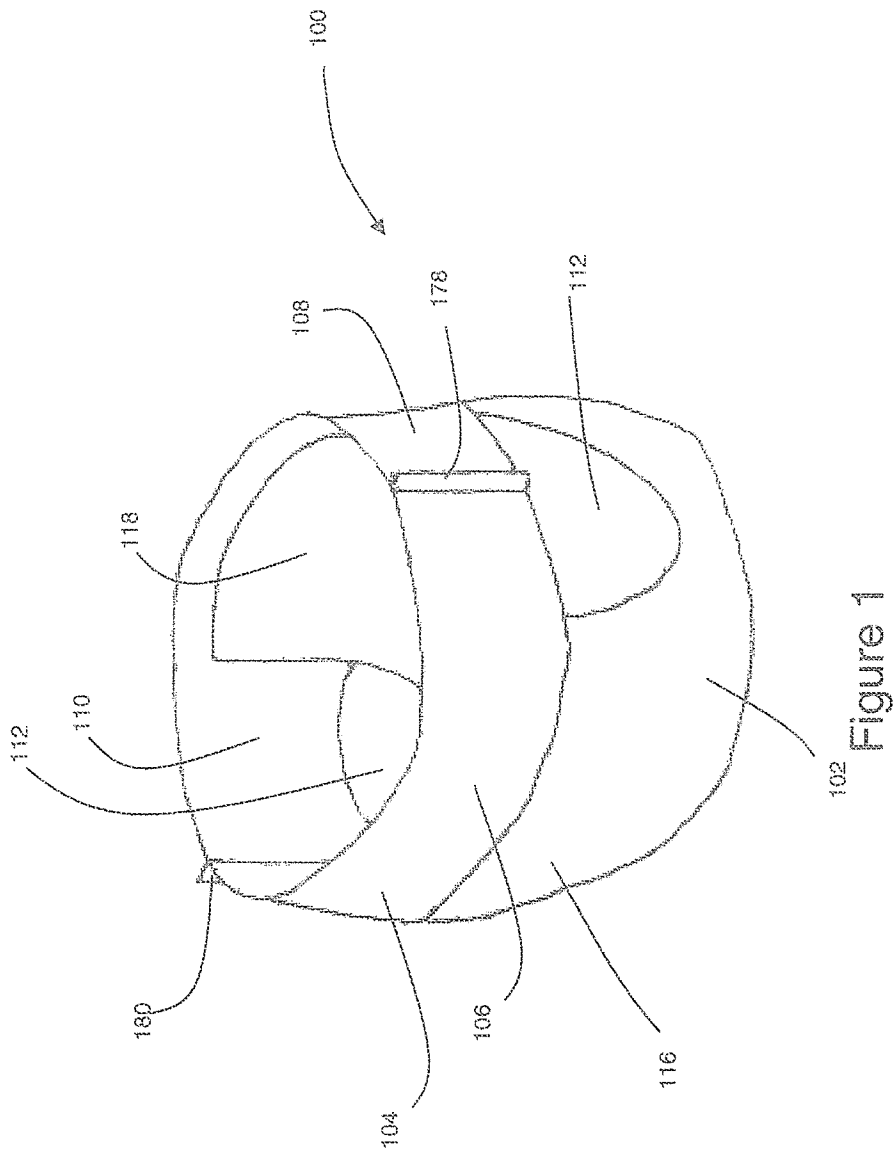

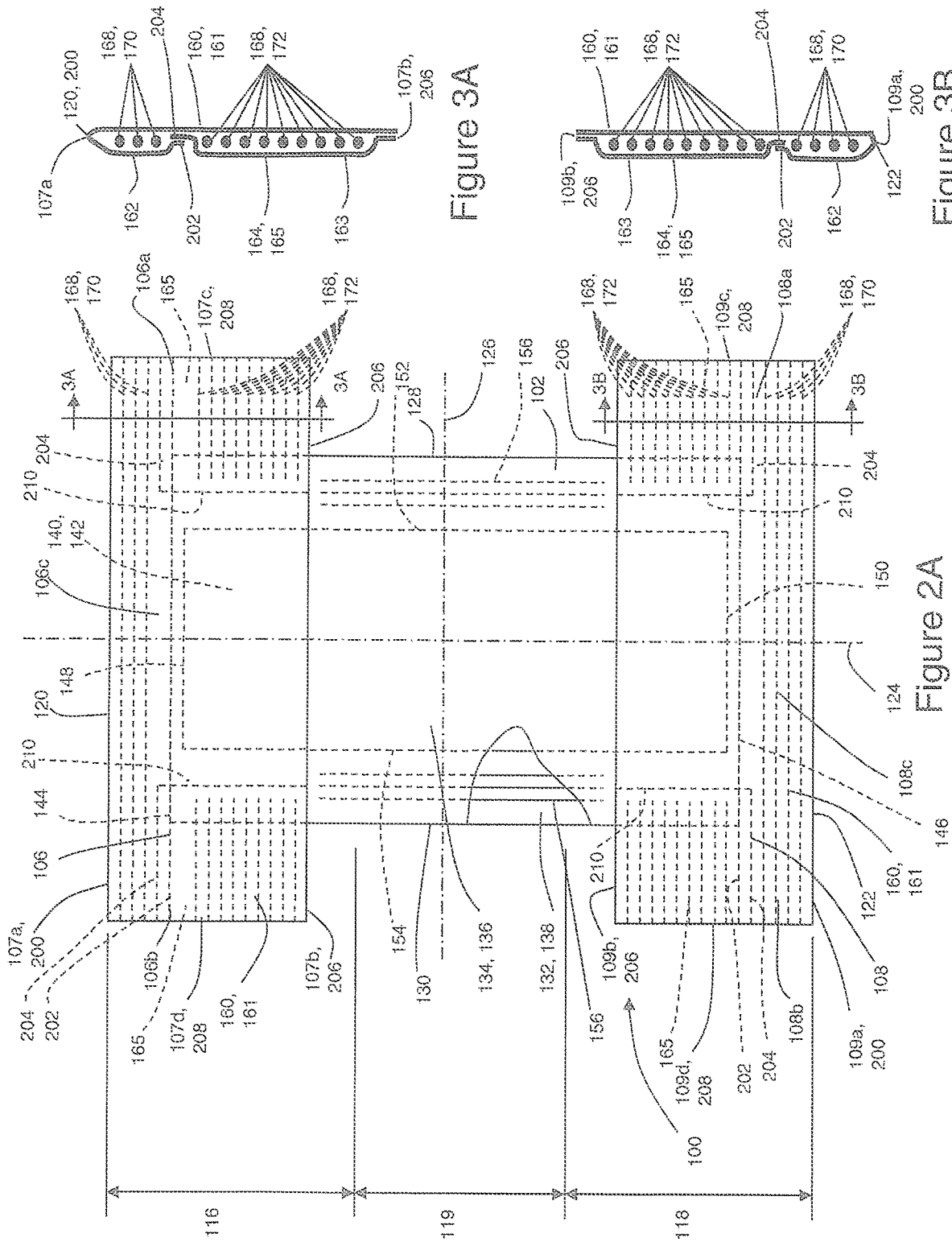

Figure 3A

Figure 3B

Figure 2A

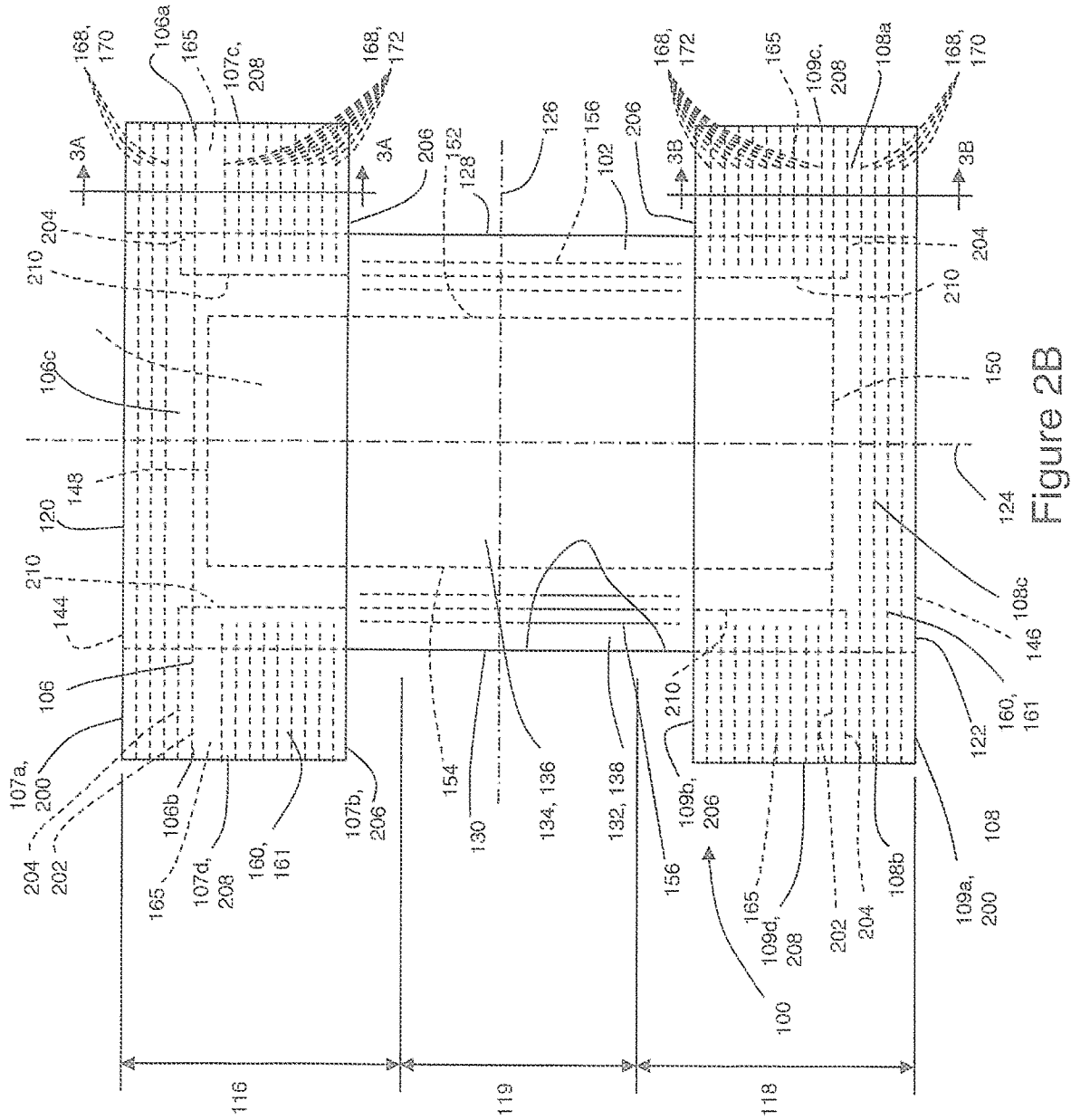

Figure 2B

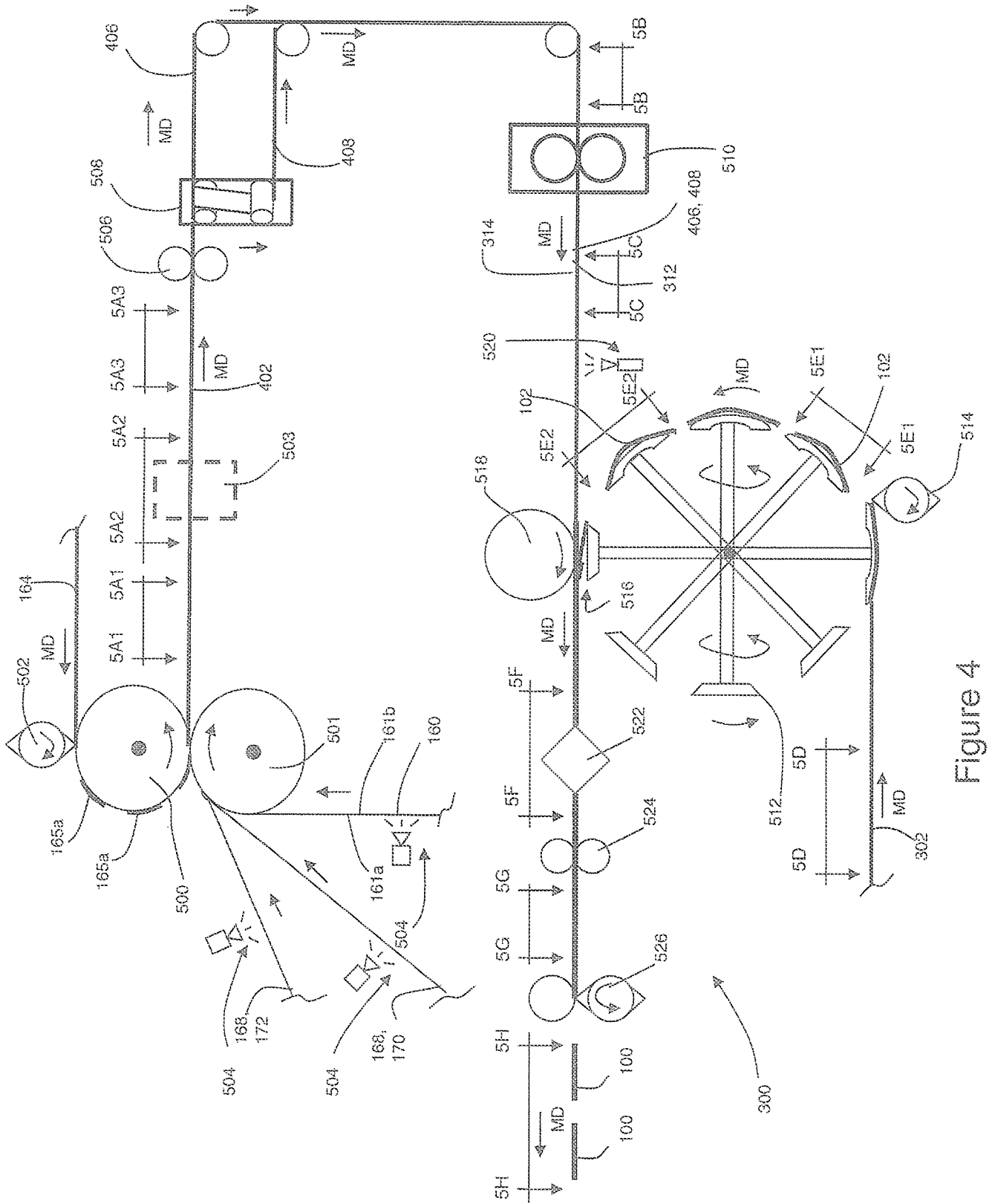

Figure 4

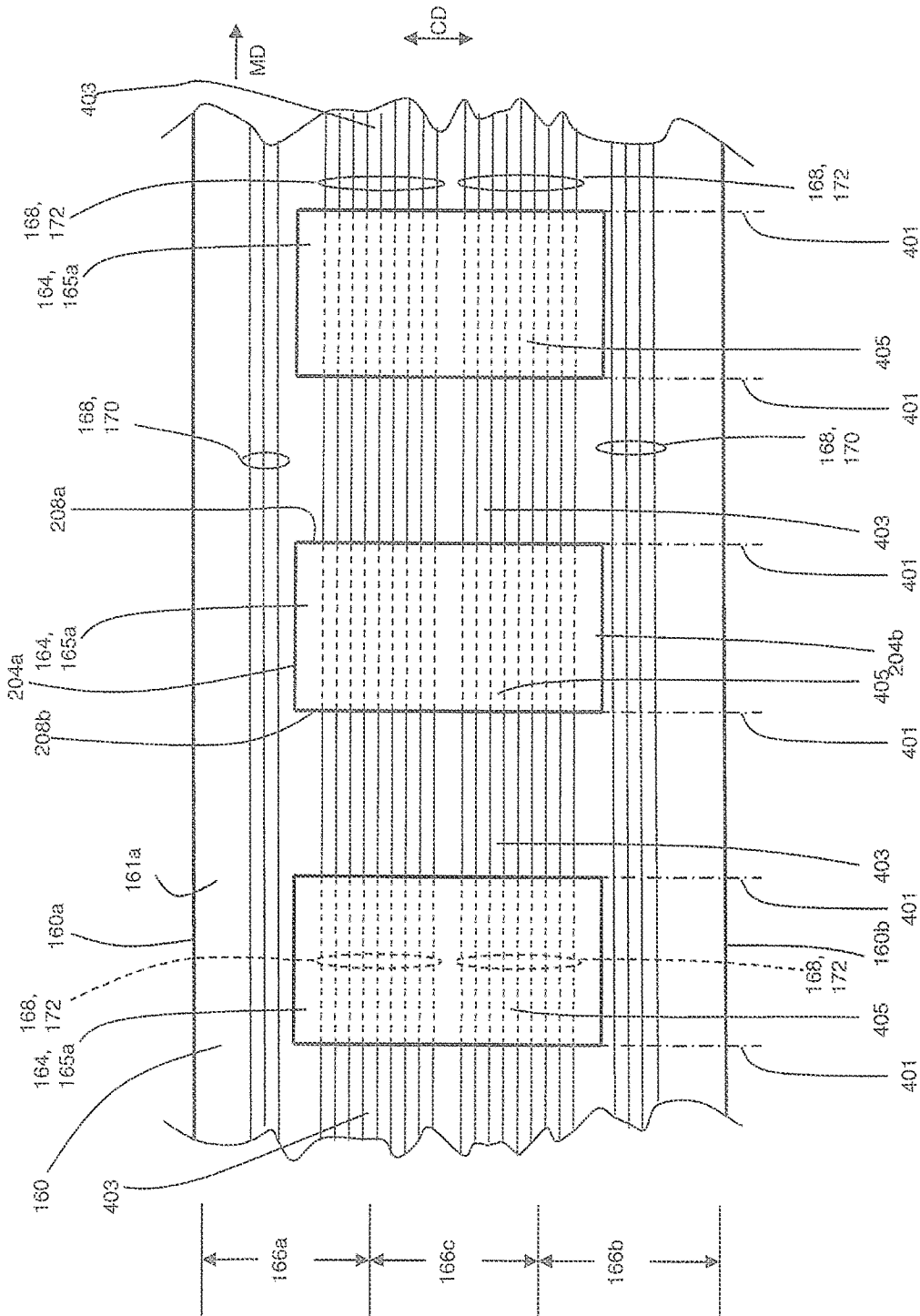

Figure 5A1

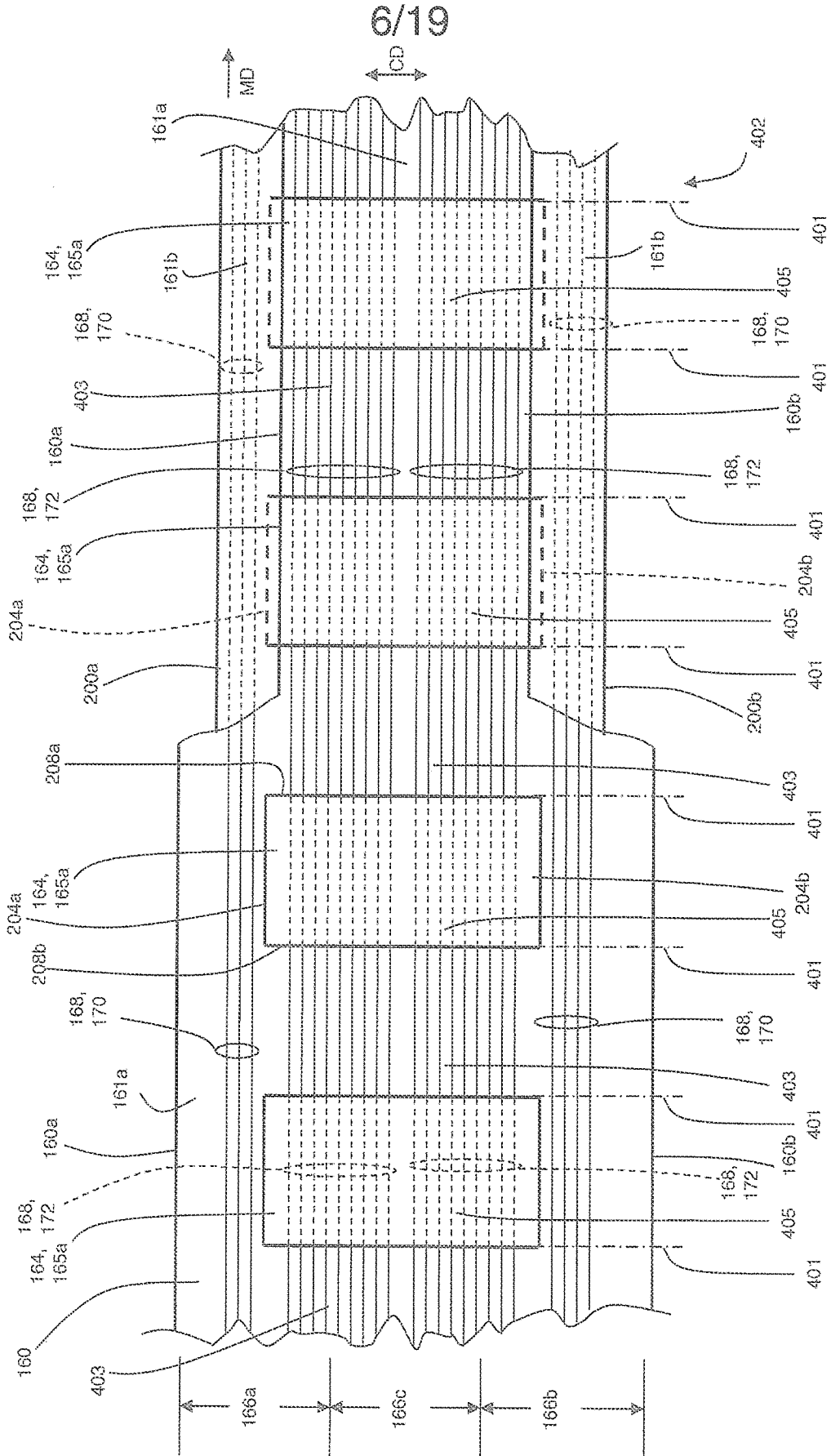

Figure 5A2

7/19

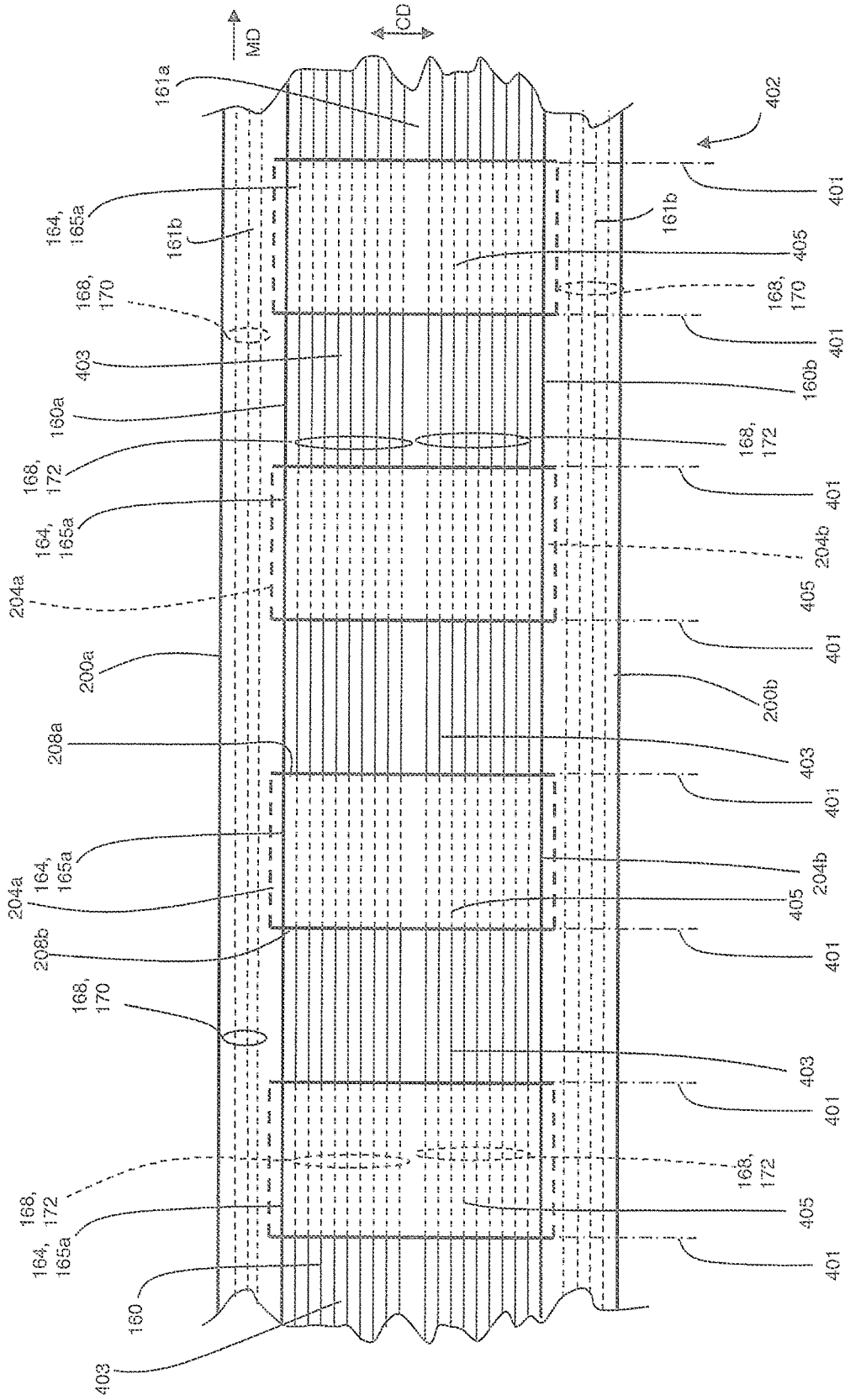

Figure 5A3

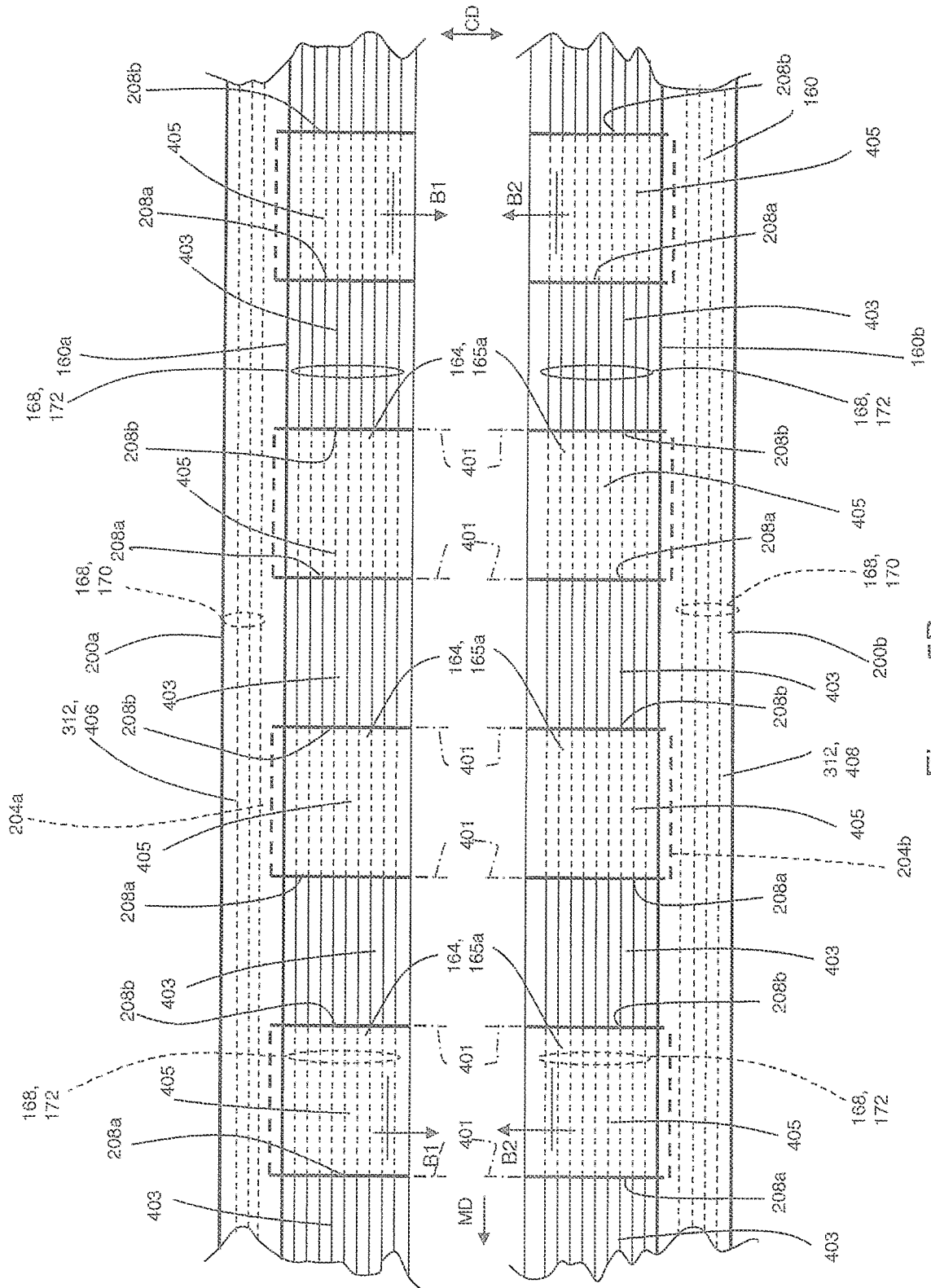

Figure 5B

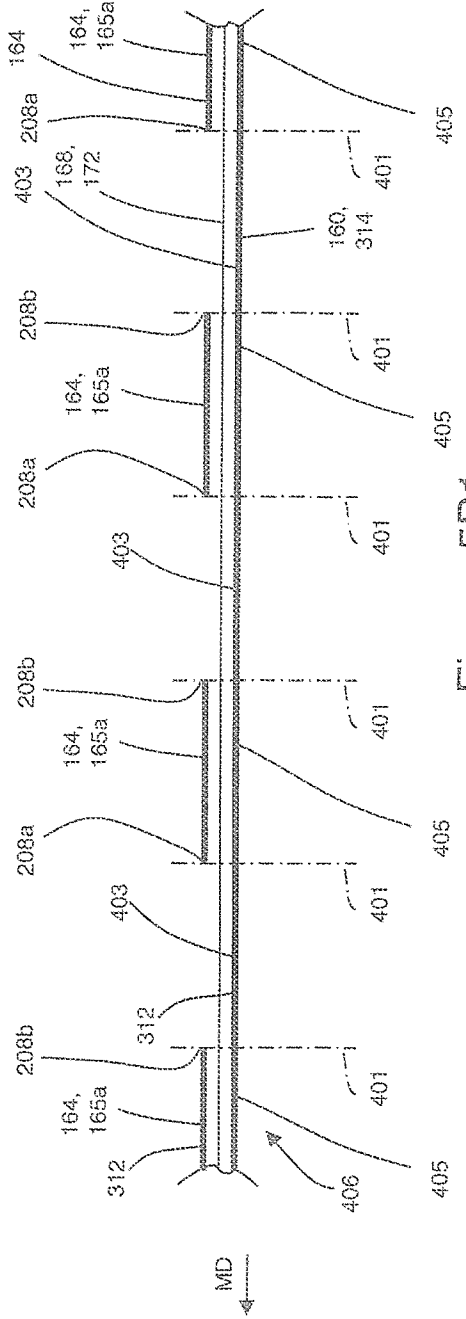

Figure 5B1

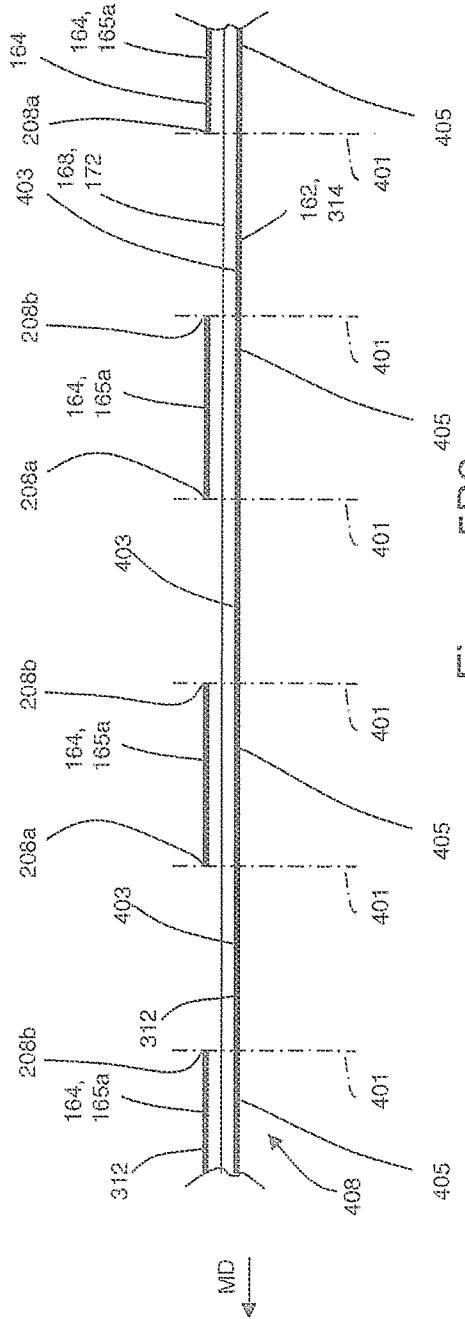
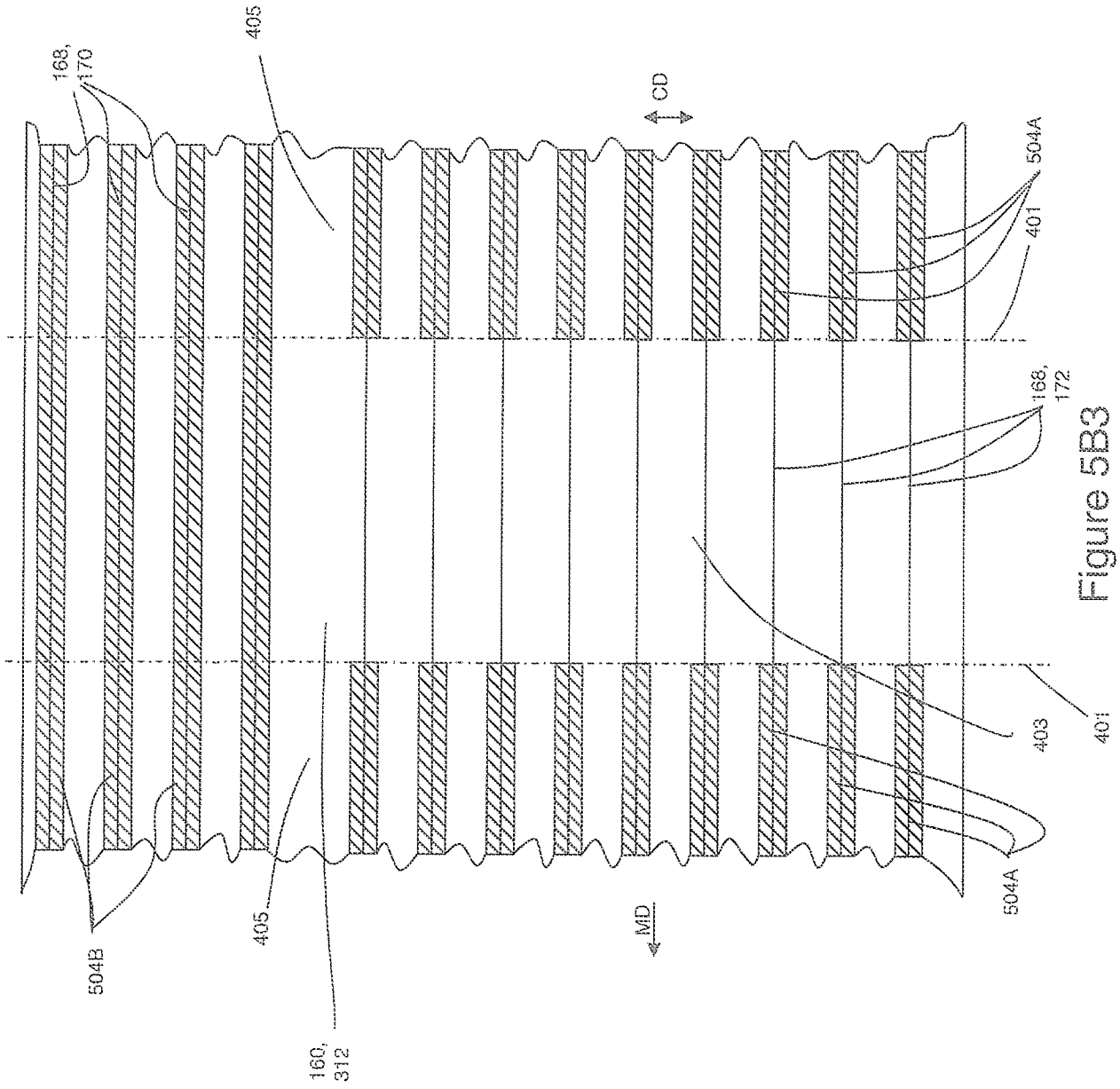

Figure 5B2



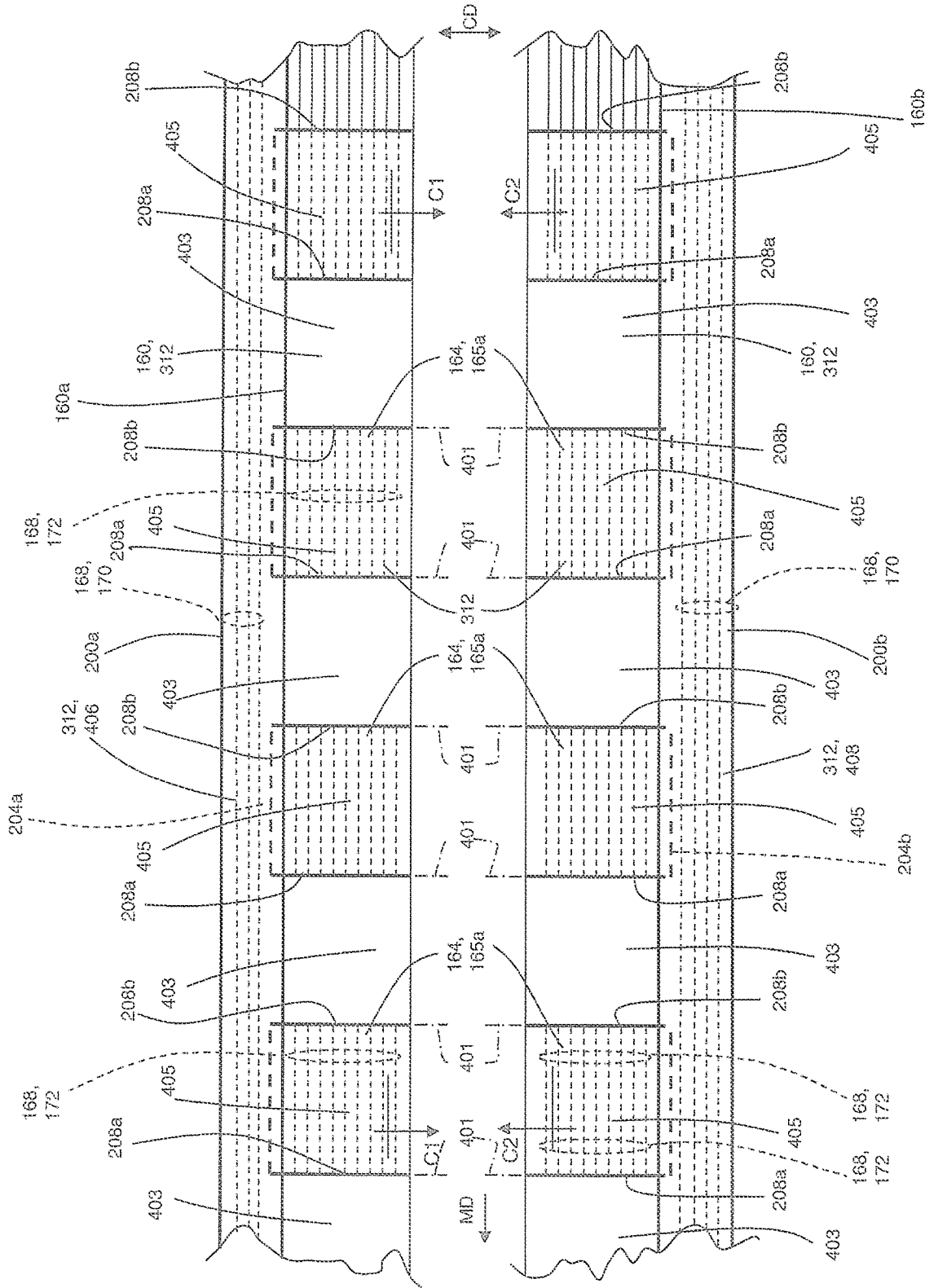

Figure 5C

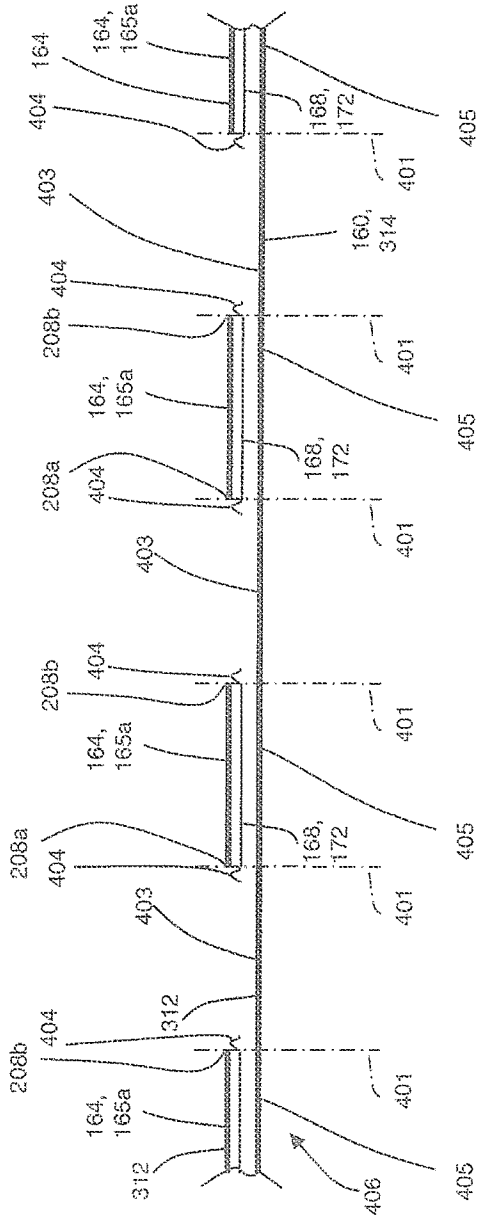

Figure 5C1

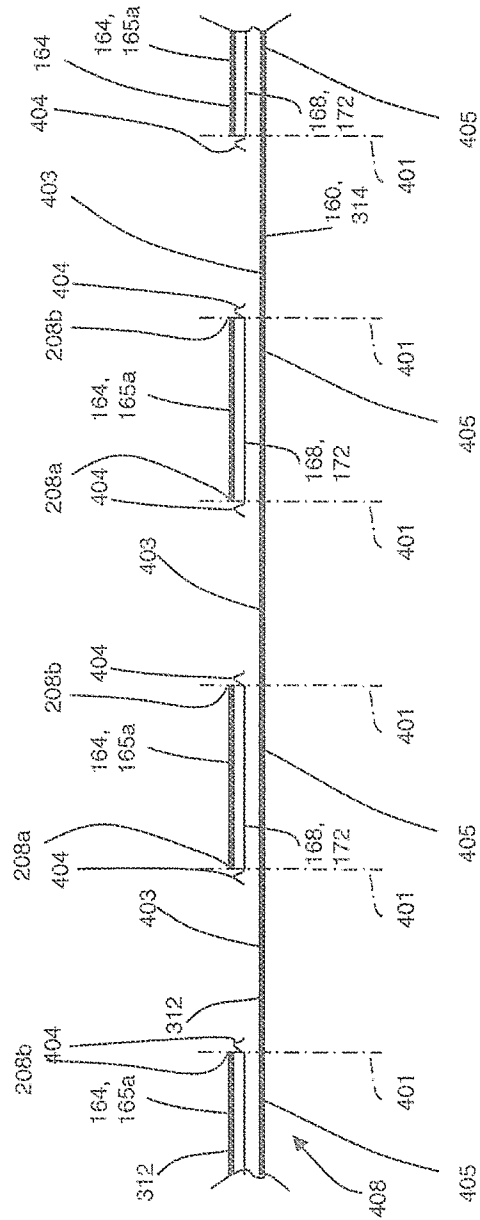

Figure 5C2

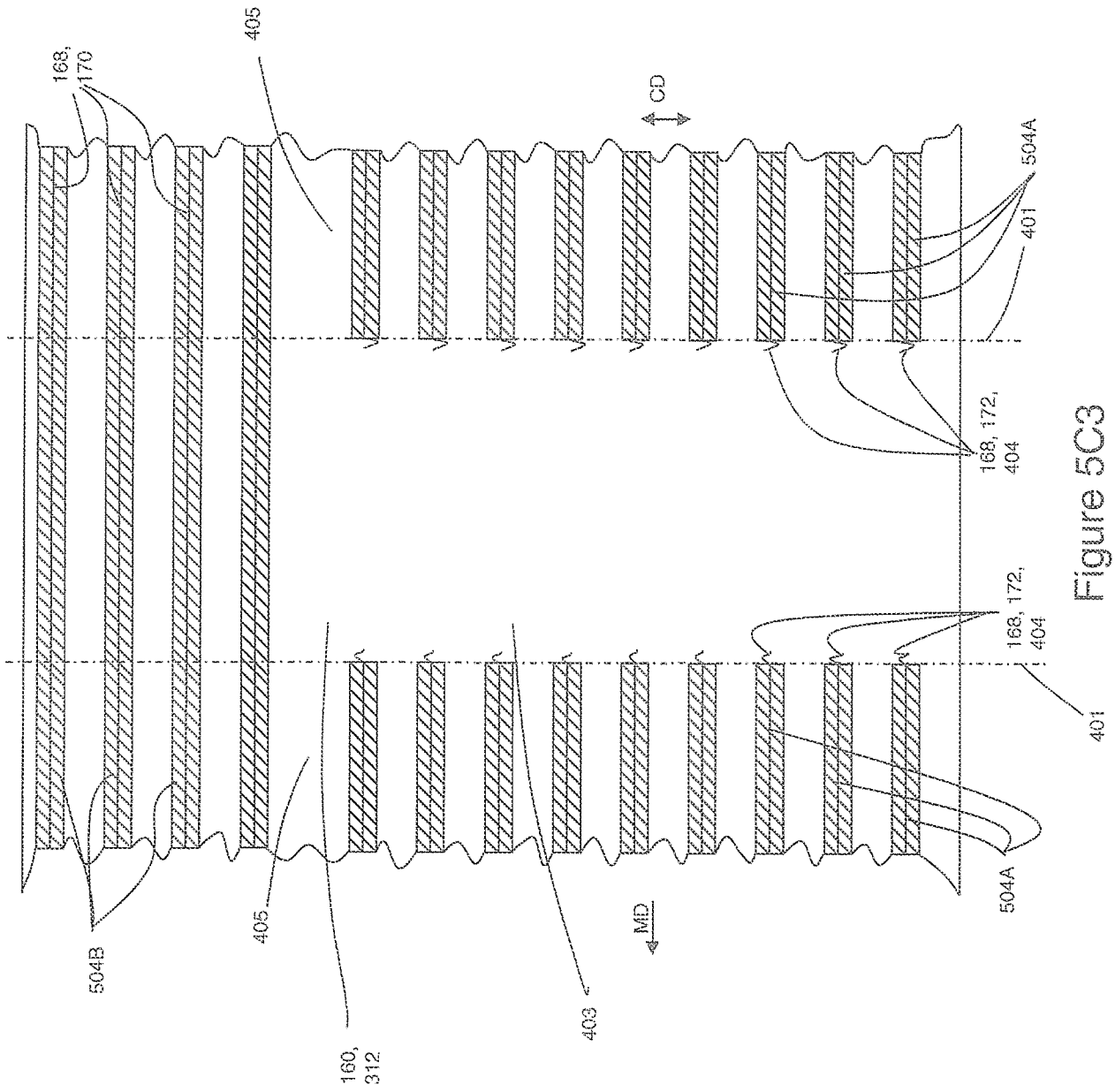

Figure 5C3

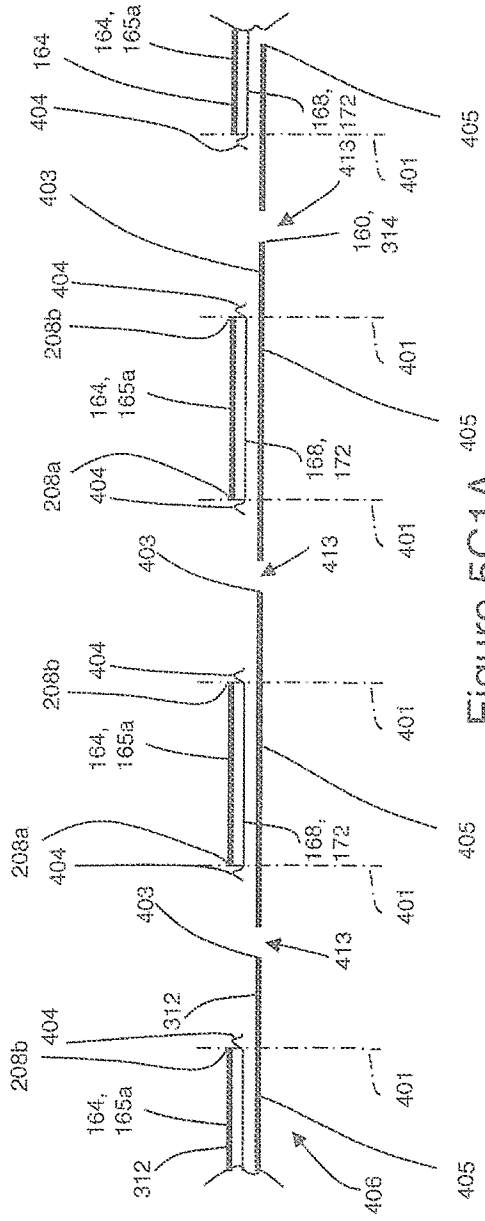

Figure 5C1A

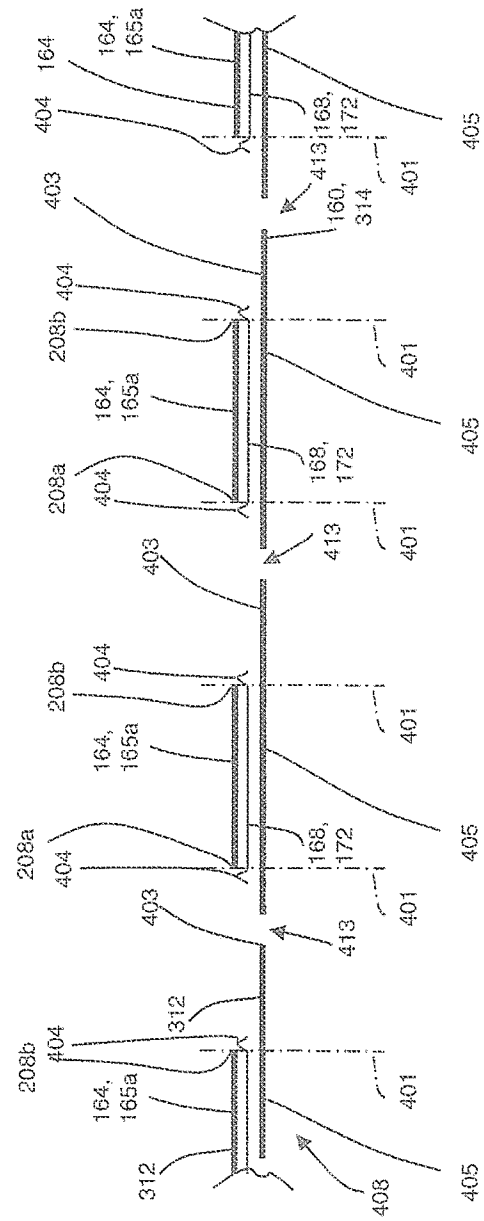

Figure 5C2A

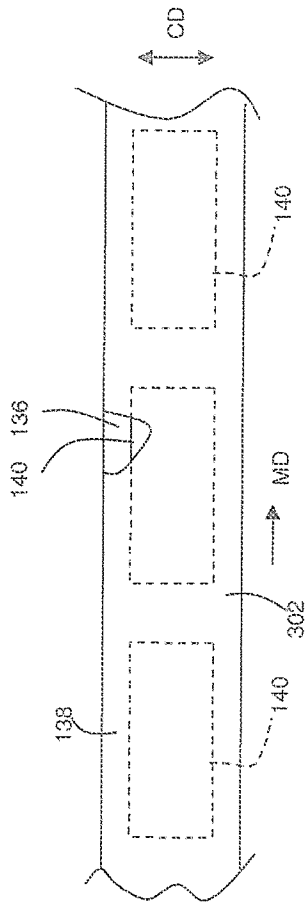

Figure 5D

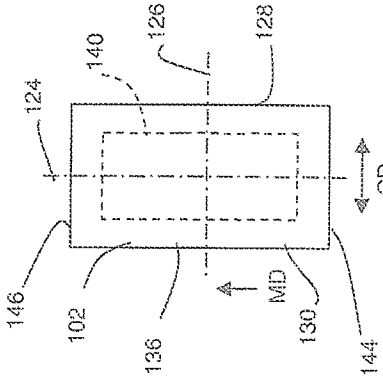

Figure 5E1

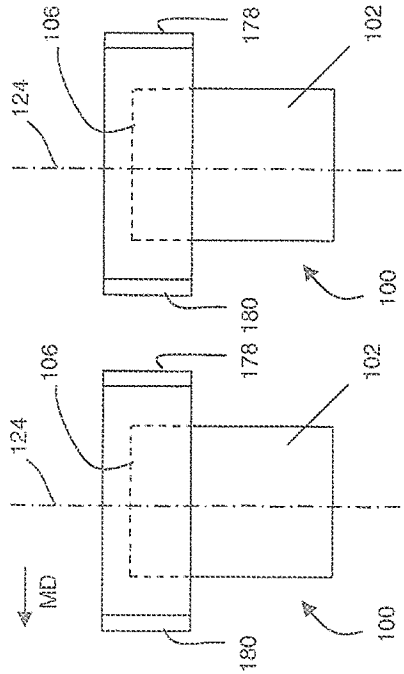

Figure 5H

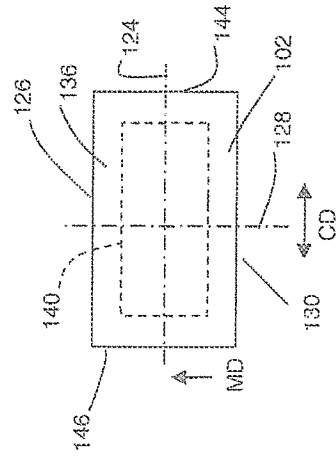

Figure 5E2

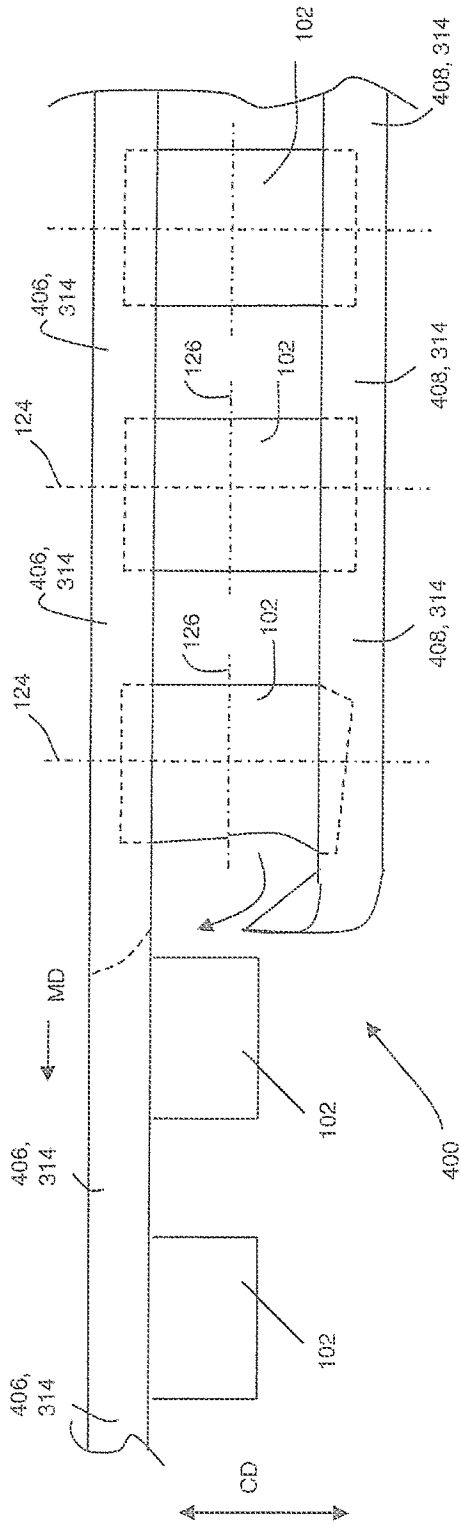

Figure 5F

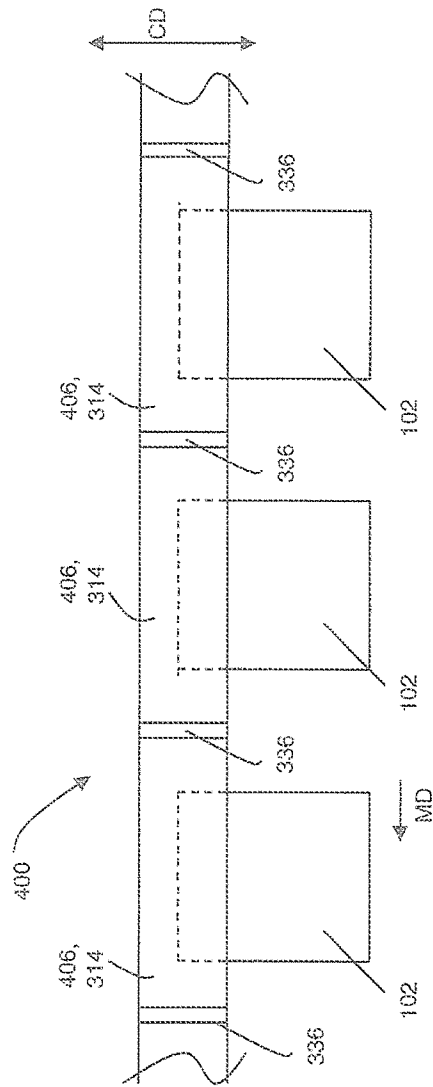

Figure 5G

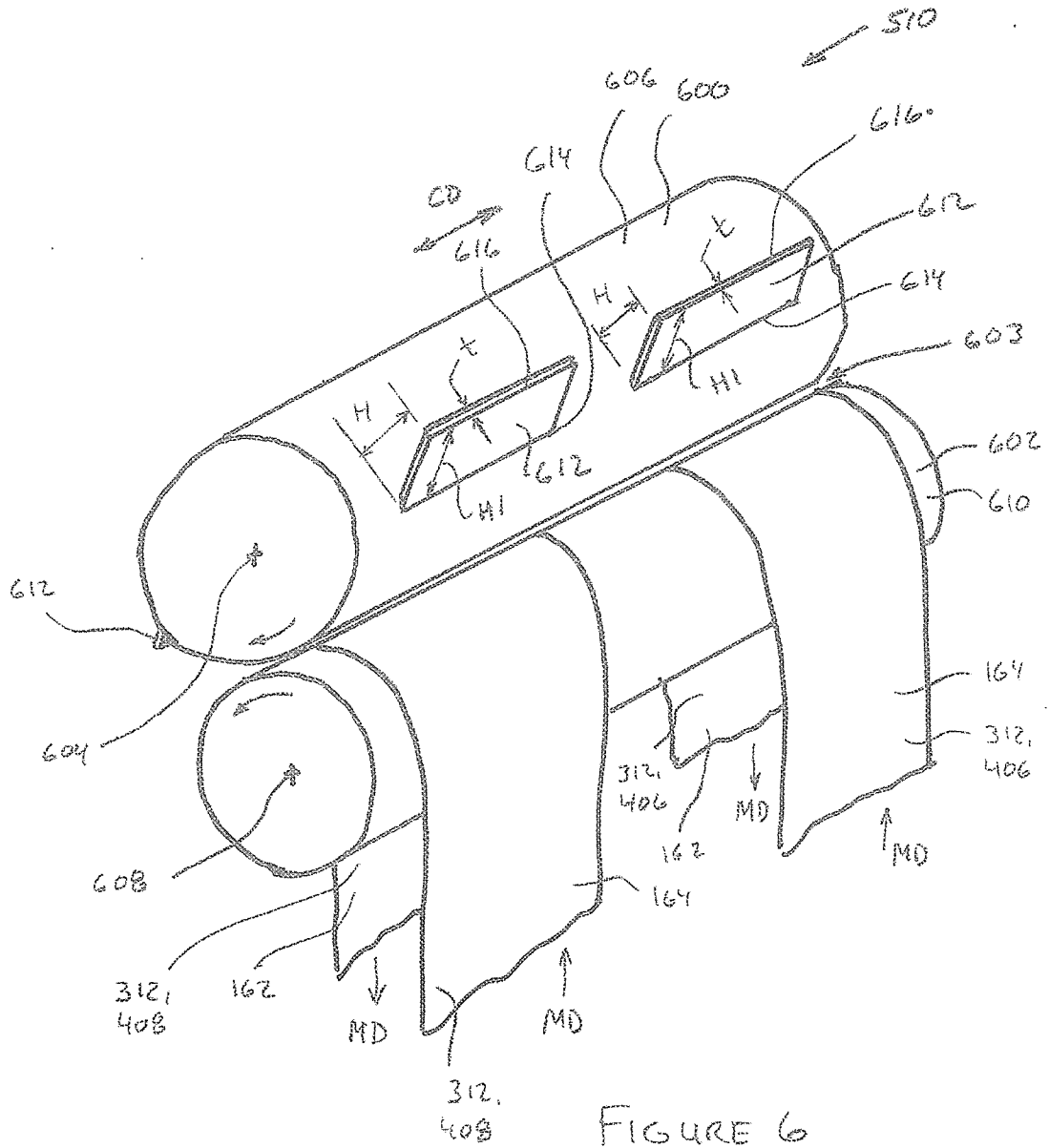

FIGURE 6

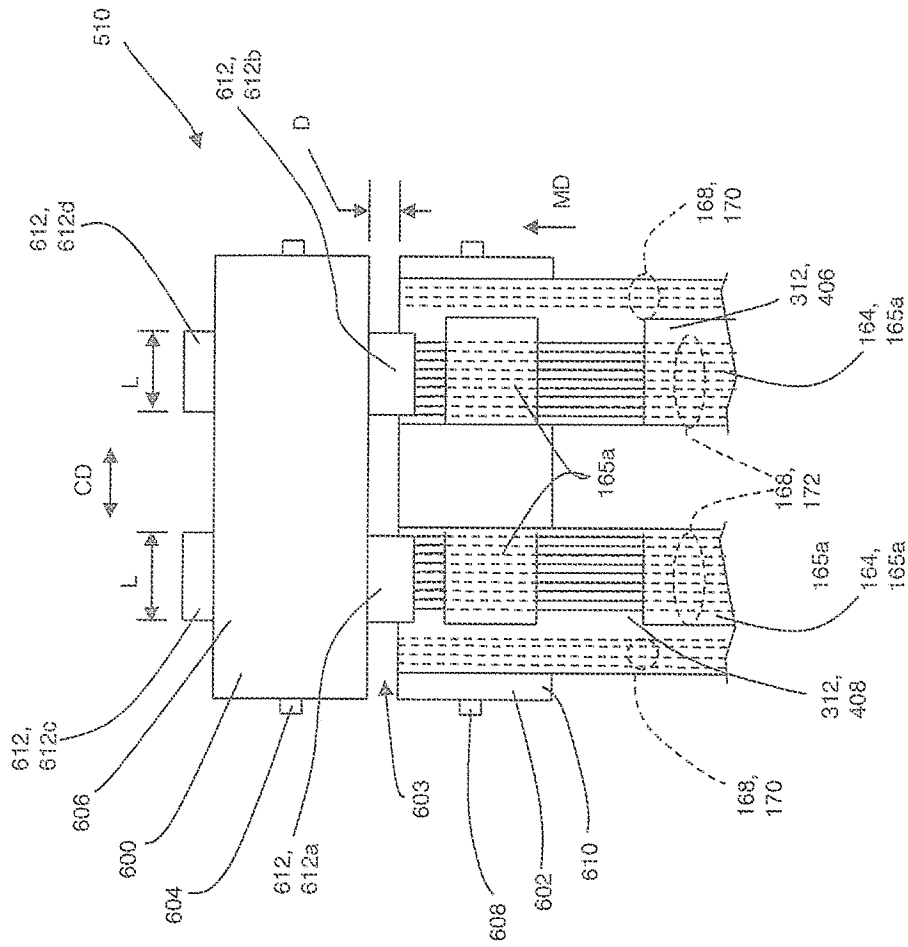

Figure 7

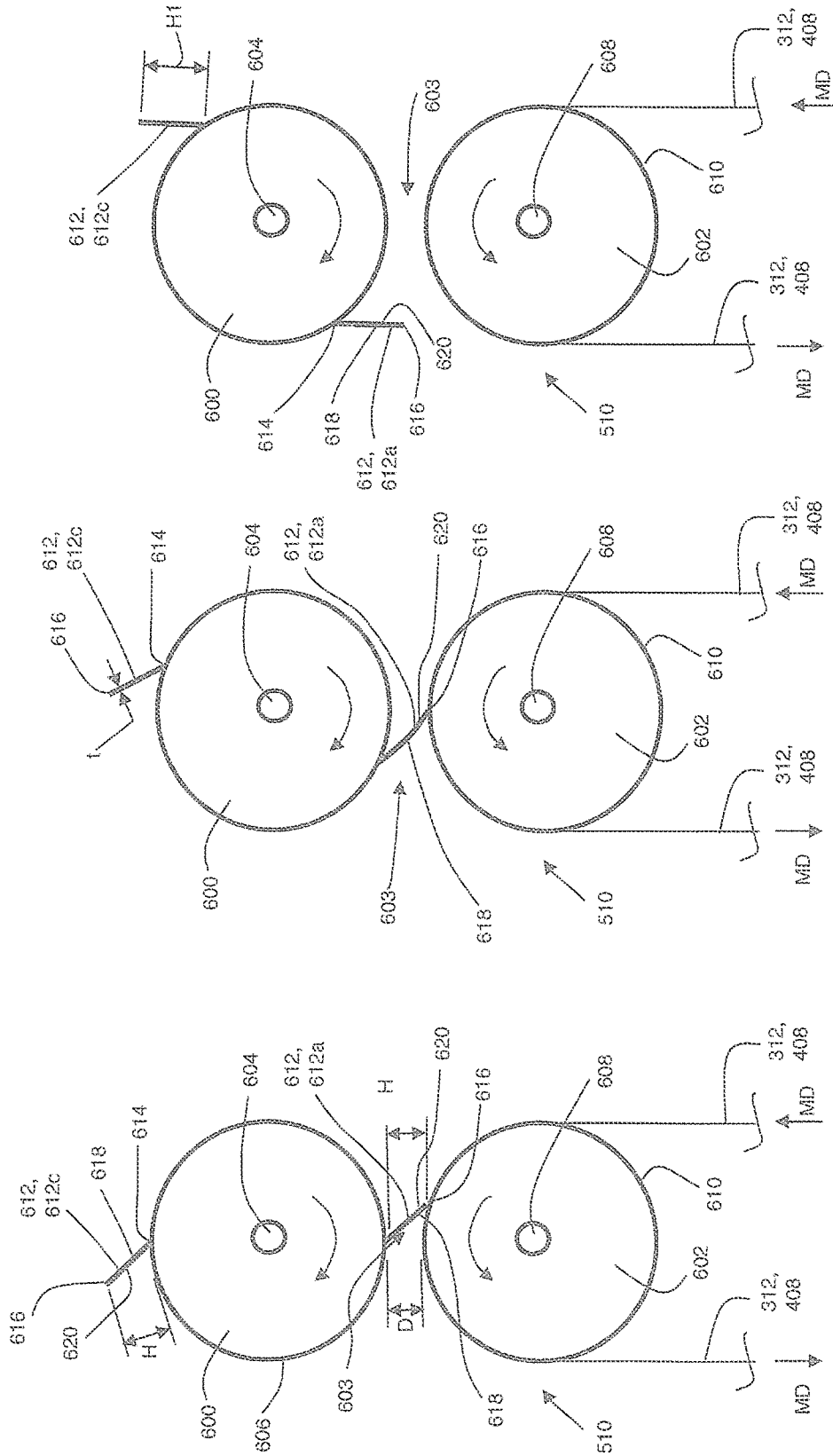

Figure 8A

Figure 8B

Figure 8C

INTERNATIONAL SEARCH REPORT

International application No
PCT/US2013/032737

A. CLASSIFICATION OF SUBJECT MATTER
INV. A61F13/15
ADD.
According to International Patent Classification (IPC) or to both national classification and IPC

B. FIELDS SEARCHED
Minimum documentation searched (classification system followed by classification symbols)
A61F

Documentation searched other than minimum documentation to the extent that such documents are included in the fields searched

Electronic data base consulted during the international search (name of data base and, where practicable, search terms used)
EPO-Internal, WPI Data

C. DOCUMENTS CONSIDERED TO BE RELEVANT

Category*	Citation of document, with indication, where appropriate, of the relevant passages	Relevant to claim No.
X	US 2004/035521 A1 (NAKAKADO MASAKI [JP] ET AL) 26 February 2004 (2004-02-26)	1-9,11
Y	claims; figures	10,12-14
Y	US 2004/158217 A1 (WU LANYING Z [US] ET AL) 12 August 2004 (2004-08-12)	10,12,13
Y	paragraphs [0095] - [0102]	
Y	US 2008/028902 A1 (BAGGOT JAMES LEO [US] ET AL) 7 February 2008 (2008-02-07)	14
Y	paragraph [0040]	
A	EP 2 415 430 A1 (UNI CHARM CORP [JP]) 8 February 2012 (2012-02-08)	1
	claims; figures	
	----- -/--	

Further documents are listed in the continuation of Box C.

See patent family annex.

* Special categories of cited documents :

- "A" document defining the general state of the art which is not considered to be of particular relevance
- "E" earlier application or patent but published on or after the international filing date
- "L" document which may throw doubts on priority claim(s) or which is cited to establish the publication date of another citation or other special reason (as specified)
- "O" document referring to an oral disclosure, use, exhibition or other means
- "P" document published prior to the international filing date but later than the priority date claimed

- "T" later document published after the international filing date or priority date and not in conflict with the application but cited to understand the principle or theory underlying the invention
- "X" document of particular relevance; the claimed invention cannot be considered novel or cannot be considered to involve an inventive step when the document is taken alone
- "Y" document of particular relevance; the claimed invention cannot be considered to involve an inventive step when the document is combined with one or more other such documents, such combination being obvious to a person skilled in the art
- "&" document member of the same patent family

Date of the actual completion of the international search 28 May 2013	Date of mailing of the international search report 05/06/2013
--	--

Name and mailing address of the ISA/ European Patent Office, P.B. 5818 Patentlaan 2 NL - 2280 HV Rijswijk Tel. (+31-70) 340-2040, Fax: (+31-70) 340-3016	Authorized officer Douskas, K
--	--------------------------------------

INTERNATIONAL SEARCH REPORT

International application No
PCT/US2013/032737

C(Continuation). DOCUMENTS CONSIDERED TO BE RELEVANT		
Category*	Citation of document, with indication, where appropriate, of the relevant passages	Relevant to claim No.
A	US 2010/252178 A1 (TAKINO SHUNSUKE [JP] ET AL) 7 October 2010 (2010-10-07) claims; figures -----	1
A	GB 2 106 441 A (MOLINS PLC [GB]) 13 April 1983 (1983-04-13) page 1, lines 52-63 -----	14

INTERNATIONAL SEARCH REPORT

Information on patent family members

International application No PCT/US2013/032737

Patent document cited in search report	Publication date	Patent family member(s)	Publication date
US 2004035521	A1	26-02-2004	US 2004035521 A1 26-02-2004
			US 2005241751 A1 03-11-2005
			US 2006032589 A1 16-02-2006
			US 2011188985 A1 04-08-2011
			US 2011196331 A1 11-08-2011
			US 2011212818 A1 01-09-2011

US 2004158217	A1	12-08-2004	CA 2536686 A1 07-04-2005
			EP 1680059 A2 19-07-2006
			MX PA06003288 A 08-06-2006
			US 2004158217 A1 12-08-2004
			WO 2005030090 A2 07-04-2005

US 2008028902	A1	07-02-2008	BR PI0715077 A2 25-12-2012
			EP 2046673 A2 15-04-2009
			JP 2009545461 A 24-12-2009
			TW 200827119 A 01-07-2008
			US 2008028902 A1 07-02-2008
			WO 2008015588 A2 07-02-2008

EP 2415430	A1	08-02-2012	CN 102427787 A 25-04-2012
			EA 201101444 A1 30-05-2012
			EP 2415430 A1 08-02-2012
			JP 2010240112 A 28-10-2010
			KR 20110139760 A 29-12-2011
			US 2012086145 A1 12-04-2012
			WO 2010113609 A1 07-10-2010

US 2010252178	A1	07-10-2010	AU 2008294255 A1 12-03-2009
			CN 101820840 A 01-09-2010
			EP 2186493 A1 19-05-2010
			JP 2009061045 A 26-03-2009
			US 2010252178 A1 07-10-2010
			WO 2009031359 A1 12-03-2009

GB 2106441	A	13-04-1983	NONE
