

(19) World Intellectual Property Organization
International Bureau



(43) International Publication Date
8 February 2007 (08.02.2007)

PCT

(10) International Publication Number
WO 2007/015770 A1

(51) International Patent Classification:
C12M 3/06 (2006.01) *B01L 3/08* (2006.01)

(74) Agent: **SCHAEBERLE, Timothy, M.**; Corning Incorporated, Patent Department//SP-TI-3-1, Corning, New York 14831 (US).

(21) International Application Number:
PCT/US2006/027475

(81) Designated States (unless otherwise indicated, for every kind of national protection available): AE, AG, AL, AM, AT, AU, AZ, BA, BB, BG, BR, BW, BY, BZ, CA, CH, CN, CO, CR, CU, CZ, DE, DK, DM, DZ, EC, EE, EG, ES, FI, GB, GD, GE, GH, GM, HN, HR, HU, ID, IL, IN, IS, JP, KE, KG, KM, KN, KP, KR, KZ, LA, LC, LK, LR, LS, LT, LU, LV, LY, MA, MD, MG, MK, MN, MW, MX, MZ, NA, NG, NI, NO, NZ, OM, PG, PH, PL, PT, RO, RS, RU, SC, SD, SE, SG, SK, SL, SM, SY, TJ, TM, TN, TR, TT, TZ, UA, UG, US, UZ, VC, VN, ZA, ZM, ZW.

(22) International Filing Date: 13 July 2006 (13.07.2006)

(25) Filing Language: English

(26) Publication Language: English

(30) Priority Data:
60/702,896 26 July 2005 (26.07.2005) US
11/433,859 11 May 2006 (11.05.2006) US

(84) Designated States (unless otherwise indicated, for every kind of regional protection available): ARIPO (BW, GH, GM, KE, LS, MW, MZ, NA, SD, SL, SZ, TZ, UG, ZM, ZW), Eurasian (AM, AZ, BY, KG, KZ, MD, RU, TJ, TM), European (AT, BE, BG, CH, CY, CZ, DE, DK, EE, ES, FI, FR, GB, GR, HU, IE, IS, IT, LT, LU, LV, MC, NL, PL, PT, RO, SE, SI, SK, TR), OAPI (BF, BJ, CF, CG, CI, CM, GA, GN, GQ, GW, ML, MR, NE, SN, TD, TG).

(71) Applicant (for all designated States except US): **CORNING INCORPORATED** [US/US]; 1 Riverfront Plaza, Corning, New York 14831 (US).

(72) Inventors; and

(75) Inventors/Applicants (for US only): **MARTIN, Gregory R** [US/US]; 227 Peck Road, Acton, Maine 04001 (US). **TANNER, Allison J** [US/US]; 380 Greenleaf Avenue, Portsmouth, New Hampshire 03801 (US).

Published:
— with international search report

[Continued on next page]

(54) Title: MULTILAYERED CELL CULTURE APPARATUS

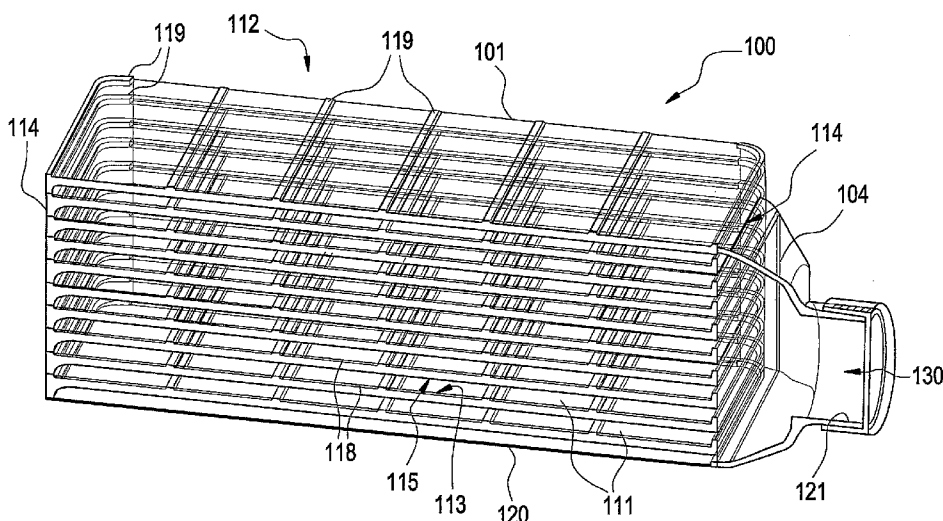

(57) Abstract: A multilayered cell culture apparatus (100) for the culturing of cells is disclosed. The cell culture apparatus is defined as an integral structure having a plurality of cell culture chambers (111) in combination with tracheal space (s) (118). The body of the apparatus has imparted therein gas permeable membranes (113) in combination with tracheal spaces that will allow the free flow of gases between the cell culture chambers and the external environment. The flask body also includes an aperture (130) that will allow access to the cell growth chambers by means of a needle or cannula. The size of the apparatus, and location of an optional neck and cap section, allows for its manipulation by standard automated assay equipment, further making the apparatus ideal for high throughput applications.

WO 2007/015770 A1



For two-letter codes and other abbreviations, refer to the "Guidance Notes on Codes and Abbreviations" appearing at the beginning of each regular issue of the PCT Gazette.

MULTILAYERED CELL CULTURE APPARATUS

CROSS-REFERENCE TO RELATED APPLICATIONS

5 This application claims the benefit of U.S. Application Serial No. 60/702,896
filed on July 26, 2005 and entitled "Multilayered Cell Culture Apparatus" which is
incorporated by reference herein in.

FIELD OF THE INVENTION

10 The present invention relates generally to the cellular biological field and, in
particular, to a cell cultivating flask.

BACKGROUND OF THE INVENTION

15 In vitro culturing of cells provides material necessary for research in
pharmacology, physiology, and toxicology. The environmental conditions created for
cultured cells should resemble as closely as possible the conditions experienced by the
cells in vivo. One example of a suitable environment for culturing cells is a common
laboratory flask such as demonstrated in United States Patent 4,770,854 to Lyman. The
cells attach to and grow on the bottom wall of the flask, immersed in a suitable
sustaining media. The flask is kept in an incubator to maintain it at the proper
20 temperature and atmosphere.

Although most cells will tolerate a hydrogen ion concentration (pH) range of
6.8 to 7.8, the optimal pH for growth of mammalian cells is 7.2 to 7.4. For the optimal
pH to be maintained during cell cultivation, the cell culture medium must contain a
buffering system.

Frequently, pH is maintained by using a bicarbonate buffering system in the medium, in conjunction with an incubator atmosphere of approximately 5 to 7 percent carbon dioxide by volume. The carbon dioxide reacts with the water to form carbonic acid which in turn interacts with bicarbonate ions in the medium to form a buffering system which maintains the pH near physiological levels. Entry of carbon dioxide from the incubator into the cell culture flask is generally achieved by using a loosely fitting or vented cap or cover so that the small opening remains for the exchange of gas between flask and incubator. Further, flasks have been sold that are made from impact resistant polystyrene plastic which is permeable to water vapor, oxygen and carbon dioxide. However, relying only on the gas exchange through the polystyrene is generally ineffective since the vessel wall thickness greatly decreases the permeability rate. Further still, flasks have been made having a cell growth surface that is itself an extremely thin (approximately 0.004 inches thick) flexible, gas permeable membrane. While this type of construction allows for gas exchange, the flexibility and thinness of the growth surface makes the growth of a uniform surface difficult and contributes to problems associated with the durability of the flask.

Gas exchange, particularly the utilization of oxygen by the cells, is a factor that limits the area for cell growth within a cell culture flask. Since flasks for cell culture typically grow attachment dependent cells in a monolayer roughly equal in size to the footprint of the flask, media volume is therefore restricted to an area within the flask permissive to the diffusion of oxygen. Oxygen and carbon dioxide are of particular importance to the culturing of cells. The supply of oxygen for cellular respiration and metabolic function in conventional cell culture containers occupies the head space of the container, e.g., the void space in the container that is above the surface of the cell culture medium. Thus, the volume of the container and the surfaces within conventional cell culture containers are inefficiently used. This results in limiting the rate of gas exchange and/or restricting the equilibration of gases. There is a need for a cell culture flask that can provide an increased surface area for cell growth while still permitting sufficient gas exchange for the multitude of attachment dependent cells.

Desirably, many flasks are stacked together in the incubator and a number of cultures are simultaneously grown. Small variations in the growth medium, temperature, and cell variability have a pronounced effect on the progress of the

cultures. Consequently, repeated microscopic visual inspections are needed to monitor the growth of the cells. As such, cell culture flasks are typically constructed of optically clear material that will allow such visual inspection.

5 With the advent of cell-based high throughput applications, fully automated cell culture systems have been the subject of serious development work (*see e.g.* A Review of Cell Culture Automation, M.E. Kempner, R.A. Felder, JALA Volume 7, No. 2, April/May 2002, pp. 56-62.) These automated systems employ traditional cell culture vessels (i.e. common flasks, roller bottles, and cell culture dishes) and invariably require articulated arms to uncap flasks and manipulate them much like the manual
10 operator.

There is a need for a cell culture apparatus having a rigid structure that is capable of providing an increased surface area for cell growth while also providing necessary gas exchange. Even further, it is desirable to produce a greater cell yield within commonly known flask volumes while permitting gas exchange at a surface of
15 cell attachment.

Additionally, the desired cell culture apparatus will be suitable for use in the performance of high throughput assay applications that commonly employ robotic manipulation.

20 SUMMARY OF THE INVENTION

According to an illustrative embodiment of the present invention, a cell growth apparatus for efficient culturing of cells is disclosed. The illustrative apparatus includes a unitary body including a bottom tray defining a cell growth area and a top plate, connected by side walls and end walls. At least one aperture located along any
25 periphery of the apparatus permits access to the internal volume. At least one gas permeable substrate/membrane is affixed to a support internal to the body of the apparatus. A tracheal space/chamber permits gases from an external atmosphere to be exchanged across the gas permeable, liquid impermeable membrane, into and out of the cell culture chamber(s). Further, the tracheal space is an air chamber confined by an
30 outer vessel body. Communication between a tracheal chamber and a cell growth chamber provides a uniformity of conditions for cellular growth. Furthermore, a

uniform gaseous distribution can be beneficial in providing consistency in the culturing environment.

5 One embodiment of a cell growth apparatus of the present invention includes a plurality of cell growth chambers, each having a gas permeable, liquid impermeable surface and an opposing surface. At least one tracheal chamber is in communication with at least one gas permeable, liquid impermeable surface of a cell growth chamber so that cells can exchange gases (e.g. oxygen, carbon dioxide, etc.) with an external environment. The cell growth apparatus of the present invention has at least one tracheal chamber incorporated with a plurality of cell growth chambers combined into one integral unit. The integral unit thus has multiple growth surfaces in any assembled arrangement. A preferred embodiment of a cell growth apparatus of the present invention alternates each cell growth chamber with a tracheal chamber in a vertical successive orientation whereby each cell growth chamber includes a substantially planar horizontal surface supporting the growth of attachment-dependent cells. The cell growth surface, however, may be planar and/or nonplanar to accommodate the surface area for growth. A modified or enhanced surface area in combination with one or more tracheal spaces enables a diversified area for growing cells. Subsequently, another embodiment of the present invention may include an arrangement of surfaces intermediary to cell growth surfaces and tracheal spaces. As such, cell growth chambers may be adjoined and configured so that they still have communication with a tracheal chamber.

15 When a plurality of cell culture chambers are arranged with tracheal chambers formed there-between, the tracheal chambers permit gaseous exchange between the gas permeable, liquid impermeable surface of a cell culture chamber and the external atmosphere. In a preferred embodiment of the present invention, each cell culture chamber alternates with a tracheal chamber allowing the cells greater access to external gaseous exchange.

25 One embodiment of the apparatus of the present invention utilizes a gas permeable, liquid impermeable membrane as the opposing surface of a cell culture chamber. In such an embodiment, a plurality of gas permeable substrates (internal to the body of the apparatus) can be incorporated to increase surface area for cellular growth. Preferably then, the apparatus is capable of being rotated to facilitate the

30

growth of attachment-dependent cells on an alternate surface. Each gas permeable substrate may have a tracheal space above and/or below it. One such embodiment is capable of incorporating one or more tracheal spaces between each stacked gas permeable substrate/layer. Additionally, the gas permeable membrane(s) may be treated or coated to promote cell growth.

Another embodiment of the present invention includes one or more supports to form a shelf internal to the apparatus. As such, each shelf would have at least one gas permeable substrate affixed. An alternative embodiment may incorporate lateral ribs traversing the flask body such that an internal gas permeable membrane would be further capable of supporting cellular growth. When such supports or lateral ribs are utilized, a plurality of gas permeable membranes can be arranged or housed within the support itself or affixed to one or more surfaces of the supports. It would therefore be important then, when stacking the layers or gas permeable substrates, to include a tracheal space between each layer of cell growth. Preferably, the tracheal space(s) provide uniform gaseous distribution within the cell culture chamber of the internal apparatus. Completely filling the apparatus with media would allow for optimal cellular nutrient exchange. Consequently, the uniformity of conditions for cellular growth may include a determined media volume per unit surface area. In another aspect, an integral unit of the cell culture apparatus comprises a plurality of modules, each having a cell growth chamber and a tracheal chamber. The plurality of modular gas permeable substrates are utilized to permit a plurality of cell chambers and tracheal chambers to be arranged to form one unitary apparatus of the present invention. The plurality of layers of gas permeable substrates are further capable of being interconnected or adjoined to provide a multiplicity of areas for cellular growth. The plurality of modules may be interconnected in series or staggered to permit continuous flow. For easy assembly and disassembly, individual units having snap-like features could be securely and easily adjoined.

In another embodiment of the present invention, the apparatus comprises a manifold to access the cell growth chambers of an integral unit. The manifold may further be capable of directing the flow of air, liquid, media and/or cellular material within the cell culture chamber.

While many embodiments of the present invention are suitable for static cultures, another embodiment of the present invention staggers the gas permeable substrates within the flask to permit continuous flow through the cell culture chamber. The staggered layers allow media to continuously flow or perfuse through the apparatus.

One embodiment of the present invention provides compliance with conventionally sized and shaped containers currently used such that the apparatus, device or flask of the present invention may be utilized with various equipment and instrumentation. Thus, the apparatus of the present invention may have a substantially rectangular footprint and a substantially uniform height. The rectangular footprint would have dimensions that are substantially identical to an industry standard footprint dimension for microplates. One embodiment of the configuration of the apparatus then may include a neck and/or cap located within the substantially rectangular footprint and that does not exceed the height of the integral unit.

Another embodiment of the apparatus of the present invention may comprise stand-offs either rising from an exterior surface of the top plate or descending from an exterior surface of the bottom tray.

For the addition and removal of media, the cell growth apparatus has at least one access port to access multiple growth chambers. Each cell growth chamber, however, may have individual access ports. Supplementary, the apparatus is capable of being equipped with a septum seal accessible opening or aperture either integrated within the body of the apparatus itself, or as a part of a cap. When a cap is utilized, one embodiment of the apparatus of the present invention, having a height as measured by the distance between an outermost plane of the bottom tray and an outermost plane of the top plate, has a cap, cover, and/or septum covering the aperture. The cap may have a diameter that does not exceed the height of the apparatus/flask so as to prevent interference when the flasks are stacked. Additionally, the cap may be integrally included in a top surface, side, and/or corner region of the apparatus. The apparatus of the present invention may have an aperture which defines an entry portal and another which may define an exit portal. When gas permeable substrates are stacked, the entry and exit portals may be positioned in a parallel or staggered assembly so as to permit flow or perfusion through cell culture chambers within the body of the apparatus.

Convenience then dictates the utilization of one or more optical components, such as microscopic lenses, in communication with individual cell growth chambers. These lenses would allow observation of one or more layers of cell growth. Also, and advantageously so, the apparatus is shaped and configured to enable robotic access to the interior of the apparatus without requiring cumbersome robotic arm manipulation.

The present invention also includes a method of culturing cells in the apparatus of the present invention. The method initially involves providing a apparatus for the growth of cells as previously described. Gas permeable substrates are first assembled into the desired configuration of the apparatus followed by introduction of cells and/or media into the cell culture chamber of the apparatus. Thereafter, the flask can then be incubated to meet the desirable conditions for the growth of cells. Rotation of the apparatus further permits the culturing of cells on an alternate surface of the gas permeable substrate.

BRIEF DESCRIPTION OF THE DRAWINGS

The invention is best understood from the following detailed description when read with the accompanying drawing figures. It is emphasized that the various features are not necessarily drawn to scale. In fact, the dimensions may be arbitrarily increased or decreased for clarity of discussion.

FIG. 1A is a perspective external view of an illustrative embodiment of the apparatus of the present invention.

FIG. 1B is a cross-sectional perspective side view of an illustrative embodiment of the present invention.

FIG. 1C is a partial internal side view of intermediary supports and gas permeable growth surfaces of FIG. 1A.

FIG. 2 is a top view of supports utilized in another embodiment of the present invention.

FIG. 3 is an external top view of a frame supporting a gas permeable membrane in another embodiment of the present invention.

FIG. 4 is a cross-sectional side view of another illustrative embodiment of the present invention.

FIG. 5 is an internal side view of the interconnected chambers of one embodiment of the present invention.

FIG. 5A is a side view of the external frame/body of the embodiment of FIG. 5.

FIG. 6 is an individual unit of one embodiment of the present invention.

5 FIG. 7 is another individual unit or tray of an embodiment of the present invention.

FIG. 8 is an alternative embodiment of the present invention.

FIG. 9 is another embodiment of the present invention.

10

DETAILED DESCRIPTION

In the following detailed description, for purposes of explanation and not limitation, exemplary embodiments disclosing specific details are set forth in order to provide a thorough understanding of the present invention. However, it will be apparent to one having ordinary skill in the art that the present invention may be practiced in other embodiments that depart from the specific details disclosed herein. In other instances, detailed descriptions of well-known devices and methods may be omitted so as not to obscure the description of the present invention.

15 An external view of a apparatus in accordance with one embodiment of the present invention is shown in **FIG. 1**. The apparatus **100** of this embodiment takes the form of a flask **100**; the flask **100** comprises an outer vessel body **101** (see **FIG. 1A**) defined by a top plate **110**, a bottom tray **120**, sidewalls **112**, and end walls **114**. Disposed within the flask **100** are individual cell growth chambers **111** as can be seen more clearly in a cross-sectional illustration in **FIGS. 1B** and **1C**. The individual cell growth chambers **111** are each defined by a generally transparent bottom surface **113** and a generally transparent top surface **115**. The surfaces **113** and **115** are attached to the flask body **101** along the sidewalls **112** and end walls **114**. Preferably, at least one bottom surface **113** within each chamber **111** is gas permeable, liquid impermeable material and capable for the growth of cells **117**. Each top surface **115** is preferably a rigid, generally gas impermeable material (preferably transparent) that will provide support to the cell growth chamber **111**. In this embodiment, supports **119** allow a gas permeable membrane **113** to be securely adhered thereto in a leak-proof sealing to the flask body **101**. Tracheal spaces **118** are created between each cell growth chamber

25

30

111. The opposing top surface 115 of the chamber 111 defines an upper wall to the cell growth chamber 111 as well as a bottom portion of a tracheal chamber 118. The tracheal chamber 118 is therefore inclusive of a gas permeable, liquid impermeable surface 113 of a first cell growth chamber and an opposing surface 115 to a second growth chamber 111. Supports 119 further provide structural arrangements to integrally incorporate the surfaces 113 and 115 in forming growth chambers 111 in alternation with tracheal air spaces 118 within the unitary flask 101. Each cell growth chamber 111 therefore alternates with a tracheal chamber 118 in vertical successive orientation. Accessibility to the cellular growth chambers 111 is achieved via an aperture 120 within the flask body 101. The aperture 120 having a necked opening 121 is connected to the cell growth chambers 111 via a manifold 104. The manifold 104 is a portal for manipulation of flask contents. In this embodiment, the necked opening 121 is covered by a cap 122 allowing the flask to be completely filled with media 127 without leakage.

15 In one embodiment of the present invention, the chambers 111 permit cellular growth on gas permeable membranes 113 such that multiple cell growth chambers 111 are integral with the body 101 of the apparatus 100 and are capable of being completely filled with nutrient media for the growth of cells. The series of tracheal air spaces 118 through the apparatus 100 provide gaseous communication between the cells 117 of the internal volume of the apparatus and the external environment. The tracheal spaces 118 allow oxygenation of media located within cell growth chambers 111 through the gas permeable surfaces 113. Further, the tracheal chambers 118 may take the form of any air gap or space, and do not allow entrance of liquid. As a result, a rigid cell culture apparatus 100 having multiple growth chambers 111, alternating with tracheal spaces 20 118, is cooperatively constructed to afford the benefit of equivalent gaseous distribution to a large volume of cells 117. Supplementary, the aperture 120 of the flask is resealable by way of a septum and/or cap 122 to prevent contents of the flask from spilling.

30 The apparatus 100 of the present invention may be made by any number of acceptable manufacturing methods well known to those of skill in the art. In a preferred method, the apparatus 100 is assembled from a collection of separately injection molded parts. Though any polymer suitable for molding and commonly

utilized in the manufacture of laboratory ware may be used, polystyrene is preferred. Although not required, for optical clarity, it is advantageous to maintain a thickness of no greater than 2 mm.

The bottom tray 120 and top plate 110 are preferably injection molded. Various sizes and shapes of the supports 119 may be incorporated to facilitate positioning of the membranous layers 113 for cell culture 117 within the internal flask body 101. A top view of another embodiment of the present invention (FIG. 2) has supports 219 as elevated stand-offs 219 along a frame or edge 202 of the flask 100. The supports 219 are rigid structures to support a sheet of gas permeable membrane 213 adhered to the frame 202, as well as provide a structural framework to allow multiple layers (rigid or membranous 213) to be formed within the flask 200. Alternatively, FIG. 3 illustrates an inner surface 313, whereby only a portion of each cell growth chamber 300 is gas permeable. For instance, a rigid frame 302 may support a permeable membrane 313.

Gas permeable, liquid impermeable substrates 113 may be comprised of one or more membranes known in the art. Membranes typically comprise suitable materials that may include for example: polystyrene, polyethylene, polycarbonate, polyolefin, ethylene vinyl acetate, polypropylene, polysulfone, polytetrafluoroethylene (PTFE) or compatible fluoropolymer, a silicone rubber or copolymer, poly(styrene-butadiene-styrene) or combinations of these materials. As manufacturing and compatibility for the growth of cells permits, various polymeric materials may be utilized. For its known competency, then, polystyrene may be a preferred material for the membrane (of about 0.003 inches in thickness, though various thicknesses are also permissive of cell growth). As such, the membrane may be of any thickness, preferably between about 25 and 250 microns, but ideally between approximately 25 and 125 microns. The membrane 113 allows for the free exchange of gases between the interior of the flask and the external environment and may take any size or shape, so long as the membrane is supportive of cellular growth. A preferred embodiment would include a membrane 113 that is additionally durable for manufacture, handling, and manipulation of the apparatus.

The gas permeable membrane 113 is properly affixed to the supports 119 by any number of methods including but not limited to adhesive or solvent bonding, heat sealing or welding, compression, ultrasonic welding, laser welding and/or any other

method commonly used for generating seals between parts. Laser welding around the circumference of the membrane **130** is preferred to establish a hermetic seal around the membrane region such that the membrane is flush with and fused to the face of the supports **132** such it becomes an integral portion of the interior surface of the apparatus. Once the gas permeable membrane **130** is adhered, then the top plate **110** and bottom tray **120** may be joined. The parts are held together and are adhesive bonded along the seam, ultrasonically welded, or laser welded. Preferably, laser welding equipment is utilized in a partially or fully automated assembly system. The top plate and tray are properly aligned while a laser weld is made along the outer periphery of the joint.

Advantageously and in order to enhance cell attachment and growth, the surfaces internal to the apparatus **100** are treated to enable cell growth. Treatment may be accomplished by any number of methods known in the art which include plasma discharge, corona discharge, gas plasma discharge, ion bombardment, ionizing radiation, and high intensity UV light.

Finally, when a cap **122** is provided, it may be a screw cap, snap-fit cap, cap with septum, cap with air holes, or any cap known in the art. Preferably, a cap **122** is utilized in which a septum is integral with the cap **122**. This will allow a cannula, tip or needle to access the contents of the apparatus **100** without the need for unscrewing. The septum is leak proof, puncturable and capable of resealing once the needle, tip or cannula is removed from the apparatus, even after multiple punctures. In one embodiment, the cap **122** is positioned to access the contents of the apparatus **100** via an end wall **114**. As well, the cap **122** may be positioned on a top surface **110**. Additionally, the cap arrangement can also be located such that the cap **122** does not protrude from the rectangular footprint as determined by the periphery of the apparatus **100**. Other accessibility options may include a neck and cap arrangement within a corner region of the apparatus **100**, such that the cap **122** would not protrude from the periphery of the apparatus body **101**.

In use, the apparatus **100** of the current invention is employed according to accepted cell growth methods. Cells are introduced to the apparatus **100** through the aperture via the neck (or through a septum in the aperture). Along with the cells **117**, media **127** is introduced such that the cells are immersed in the media. The apparatus is arranged such that the cell containing media covers the cell growth surfaces **113**. Advantageously, the apparatus **100** is capable of being completely filled with media

since the gas permeable membranes **113** in combination with the tracheal spaces **118** provide uniform gas distribution to the cell growth surfaces **113**. This will further ensure the flow and exchange of gases between flask interior and the external environment. The apparatus is then placed within an incubator and may be stacked together with similar vessels such that a number of cell cultures are simultaneously grown. The apparatus is situated such that the bottom tray **120** assumes a horizontal position (or vertical position depending on the cell culture application). Another advantage of the apparatus **101** of the present invention is its enhanced capacity to grow cells on an opposing surface **115** when the apparatus is rotated 180°. Thus, when the apparatus is rotated, cells can be cultured on an alternate surface **115**. As such, it would be beneficial to have the surface **115** composed of a gas permeable material. Where only gas permeable membranes are layered intermediary to the apparatus, cell growth is therefore enabled on both of its gas permeable surfaces **113/115**.

Cell growth is monitored from time to time by microscopic inspection through the generally transparent interior and exterior surfaces of the apparatus **100**. Easier accessibility and greater visibility of cellular growth can be visualized when optical lenses having varying magnifications are employed in the external body **101**. Additionally, optical lenses may be integrated within other internal surfaces of the apparatus **100**.

Additionally, during the cell growth process, it may become necessary to extract the exhausted media and insert fresh media. As previously described, media replacement may be achieved through insertion of a canula, for example, through the septum. Alternatively, the media may be replaced by removing the cap **122**, in embodiments that offer this option. Once the cells are ready for harvesting, a chemical additive such as trypsin is added to the apparatus through the septum. The trypsin has the effect of releasing the cells from the surfaces of the apparatus. The cells can then be harvested from the flask.

A cap and neck arrangement is not necessary, however, for an apparatus **400** of the present invention (**FIG. 4**). As illustrated in this embodiment, supports **432** separate a series of tracheal spaces **440** between each growth layer **450**. The tracheal air spaces provide uniform gas distribution within the flask **400** to each cell culture layer **450**. In this embodiment, the media in the individual cell growth chambers does not mix as these chambers **450** can be considered separate, and possibly, modular units

450 for easy assembly of the apparatus 400. The chambers 450, however, may be interconnected via hollow supports 432. In one embodiment, access to the interior of the apparatus 400 may be accomplished directly, through plugged ports or apertures 460 that are on an end wall 414 to allow accessibility to each cell culture/media layer 450. Another easy means of access may employ septa as coverings for the apertures 460.

Septa are capable of being integrally affixed to the body of the apparatus 400 by any of the aforementioned methods for affixing a membrane to the wall of the apparatus. The septa may take any form well known to those of skill in the art including a slit arrangement useful for blunt needles and as generally described in WO 02/066595, the contents of which are incorporated herein by reference. Possible materials that may be employed in making the septa include natural and synthetic elastomeric materials including, but not limited to silicone rubber, fluoro-carbon rubber, butyl rubber, polychloroprene rubber, a silicone elastomer composite material, thermoplastic elastomer, medical grades of silicone rubber, polyisoprene, a synthetic isoprene, silicone, santoprene and fluoropolymer laminate and combinations thereof. In a preferred embodiment, the elastomeric material is substantially nontoxic to cultured cells. Moreover, a universal septum may cover each aperture 460 while still allowing access to each individual layer of cell growth 450. This embodiment of the flask 400 may be preferred when stacking of the apparatus 400 is required, or when significant robotic manipulation is encountered since it eliminates the need for cap displacement.

FIG. 5 and 5A illustrate another embodiment of the present invention. As illustrated in partial internal and external cross-sectional views, respectively, a multilayered culture vessel 501 of the present invention is a perfusion system 500. Multiple gas permeable substrates 530 are adhered to supports/frames 532 and stacked in a parallel configuration permitting an airway or tracheal space 540 to separate each cellular growth layer 550. As in previous embodiments, the gas permeable substrates/membranes 530 in combination with the tracheal chambers 540 define the cell culture system 500. The tracheal spaces 540, alternating with layers of transparent gas permeable membrane(s) 530 and supports 532, provide air/gas exchange with media and cell cultures 550 on an alternate or opposing surface of the gas permeable

substrate **530**. As such, liquid media inside the apparatus **501** is capable of being contained within a layer **550**. In addition, the tracheal air chambers **540** under each cell growth surface **550** have gaseous communication between the cells/media layers **550** and external environment via the series of openings **541** formed between the supports **532** in the external apparatus body **501**. The necked opening **560** comprises one aperture which defines an entry portal **562** and one aperture which defines an exit portal **564**. The entry portal **566** and exit portal **568** in conjunction with the necked opening **560** allows access to the internal volume/layers **550** of the apparatus **500**. Furthermore, in this embodiment of the apparatus/vessel **501**, a raised rim **580** serving as a standoff **580** is located on the surfaces of both the top plate **510** and bottom plate **520**. The standoff rim **580** is intended to contact the bottom tray **520** of an identical vessel that is stacked on top the apparatus **501**. Stacking makes efficient use of incubator space. Another attribute of having a standoff rim **580** is the allowance of an air gap between stacked flasks; the air gap is important for allowing gas exchange through any vent that may be incorporated into an upper or underside surface of the apparatus **501**, and further prevents damage to the gas permeable membrane **530**. Other alternatives for standoffs **580** include raised corners, posts, ledges, or any other feature that will allow spacing between successively stacked flasks. Preferably, the bottom plate **520** is molded with a rim **580** around the periphery that can engage with a standoff rim **580** from an immediately adjacent apparatus to ensure lateral stability of the stacked vessels.

For exemplary purposes and not limitation, cell seedlings, media exchange, and/or cell harvesting can be accessed via the entry portal(s) **566** and exit portal(s) **568**. In combination with the portals **566/568**, linear fluid flow restrictors **564** can act as manifolds to evenly direct flow during cell harvesting. Additionally, for exemplary purposes only and not limitation, an embodiment of the present invention incorporates a staggered configuration of gas permeable substrates **530** in conjunction with the supports **532** so as to allow continuous flow or perfusion through the vessel **501**. Various arrangements of the layers **550** and stacked substrates **530**, however, would permit utilization of the vessel **501** for static cell culture or cell culture in a perfusion system as discussed, including parallel, symmetrical, or asymmetrical arrangements.

For easier accessibility and manufacturing of the multilayered apparatus **501**,

the arrangement of cell growth layers 550 and stacked substrates 530 into individual modular units may be preferred. As such, a modular unit of one embodiment of the present invention is illustrated in FIG. 6. An individual modular unit 600 comprises a support network 632 in combination with gas permeable membranes/substrates 630. A plurality of modular units 600 are capable of being interconnected and/or interlocked or adhered together to provide a multiplicity of growth surfaces 630/631 that can be easily assembled or disassembled into a unitary multilayered vessel for cellular culture. Vertical stacking of the modular units 600 would be analogous to interconnecting building blocks. Any number of cell growth layers 600 could be assembled or disassembled to provide a wide range of accessibility options to each modular cell growth unit 600. One embodiment of the present invention utilizes supports 632 forming a shelf/frame 633 along a periphery of the individual unit 600 in addition to lateral ribs 635 spanning or bisecting the distance internal to the frame 633. The transparent gas permeable substrate(s) 630 are adhered to supports 632 such that air gaps or tracheal spaces 640 are formed between each cell layer of gas permeable substrate 630 to allow gas distribution throughout the unitary apparatus when multiple trays are assembled into one vessel body. The tracheal spaces 640 have gaseous exchange with the external atmosphere via the tracheal openings/ports 641 in the external frame 633. Further, the tracheal spaces 640 provide air/gas exchange with media and cell cultures on a [primary] surface 630 and an alternate or secondary surface 631, both surfaces 630/631 capable of cell growth. As seen in this embodiment, peripheral ridges or elevations 637 of the support system 632 are utilized to facilitate stacking of the modular units 600. The gas permeable membrane 630, however, may be adhered to any of the surfaces of the support system 632 or peripheral edge 637 so as to provide a leak-proof gas permeable substrate 630 in combination with the modular unit 600 and further permitting multiple areas for cell growth on the gas permeable surfaces 630/631. Additionally, an open end 633 of the frame 632 is a feature to permit fluid flow when multiple modular units 600 are stacked and adhered together into a unitary body so as to be utilized in perfusion devices. Furthermore, one embodiment of the apparatus of the present invention encompasses one gas permeable substrate 630 providing a primary growth surface 630, as well as an [optional] gas permeable

substrate **631** providing a secondary growth surface **631** adhered to an underside of the frame network **632**.

As seen in **FIG. 7**, another embodiment of the present invention utilizes a modular unit **700** inclusive of a cap **762** covering an aperture **760**. A manifold **764** permits access to the internal cell culture layer **750**. A unitary cell culture chamber is capable of being constructed when individual units **600** and/or **700** are stacked. Further, when combined, the internal cell culture layers **650** and/or **750** would be accessible via the aperture **760** to the unitary cell culture chamber.

In utilizing the vessels of the current invention, various methods in the industry may be employed in accordance with accepted cell growth culturing. As discussed in a previous embodiment, cells are introduced to the flask though the neck or through the septum. Along with the cells, media is introduced such that the cells are immersed in the media. The apparatus is arranged such that the cell-containing media covers the cell growth surfaces. Advantageously, the apparatus is capable of being completely filled with media since the gas permeable membranes in combination with the tracheal spaces provide uniform gas distribution to the cell growth surfaces. This will furthermore ensure the flow and exchange of gases between flask interior and the external environment. The apparatus is then placed within an incubator and may be stacked together with similar flasks such that a number of cell cultures are simultaneously grown. The flask is situated such that the bottom tray assumes a horizontal position (or vertical position depending on the cell culture application). The flask can then be rotated to permit the culturing of cells on an alternate surface. Where only gas permeable membranes are layered intermediary to the apparatus, cell growth is enabled on upper and under sides of the membrane (opposing gas permeable surfaces).

Cell growth can be monitored from time to time by microscopic inspection through the generally transparent surfaces. If more detailed visual inspection of the cell growth layers is required, optical lenses can be integrated into the body or frame of the apparatus. As such, varying magnifications of the optical lenses would permit viewing within individual layers without disassembly of the apparatus. Optical lenses may be incorporated into any surface or modular unit, as well, preferably when the units are capable of being disassembled for observational analysis.

During the cell growth process, it may become necessary to extract the exhausted media and insert fresh media. As previously described, media replacement

may be achieved through insertion of a canula, for example, through the septum. Alternatively, the media may be replaced by removing the cap, in embodiments that offer this option. Once the cells are ready for harvesting, a chemical additive such as trypsin is added to the flask through the septum. The trypsin has the effect of releasing
5 the cells from the vessel surfaces. The cells are then harvested from the apparatus.

As discussed, the embodiments of the present invention are for exemplary purposes only and not limitation. Supplementary, tracheal spaces are capable of being formed above and/or below the support network when the trays are stacked upon one another where peripheral ridges of individual modular units permit gaps of air to flow
10 through gas permeable substrates to cell growth areas when the units are interconnected. The tracheal spaces formed within the individual units are further capable of including a diversified network of supports, intersecting and/or alternating gas permeable membrane with supports and air/tracheal spaces.

The gas permeable substrates utilized in the embodiments of the present
15 invention are capable of cell growth and gas exchange with the external environment, achieving uniform gaseous distribution throughout the cell culture vessel. Furthermore, the apparatus of the present invention may utilize horizontal or vertical designs having surfaces arranged for uniform gaseous distribution to cell growth areas. As seen in one embodiment of the present invention in **FIG. 8**, vertical growth surfaces or gas
20 permeable substrates **830** are separated by tracheal spaces **840**. The tracheal spaces **840** allow for the exchange of oxygen, carbon dioxide, and other various gases between the respiratory/gas permeable surfaces **830** that the cells grow on and the incubator or external atmosphere where the apparatus **800** is stored while the cells are given time to grow. The apparatus **800** of the present invention may include a cap **862** and/or a
25 manifold **864**, as well, which is unitary with the vessel body **800**.

Another embodiment of the present invention (**FIG. 9**) is an apparatus **900** that includes an external manifold **965** allowing access to individual cell growth layers **930** via a septum as discussed previously. The units **930** are modular and joined together to handle as one. Furthermore, tracheal spaces **940** allow uniform gaseous distribution to
30 cell growth areas **930** throughout the flask **900**. The uniformity of conditions for cellular growth may include a determined media volume per unit surface area. Though the determined ratio of volume per unit surface area has previously been known within a confined range of about 0.5 – 1.0 ml/cm², the ratio is no longer limiting due to the

direct access of the cells to gaseous exchange via the gas permeable membrane upon which the cells grow. While efficient use of media is still preferable, any volume of media may be utilized in an apparatus of this invention, the apparatus of which may be any size and/or take any shape. Further, the enhanced capabilities of the present invention may incorporate tracheal spaces in combination with cell growth chambers into standardized or conventionally-sized containers. One embodiment of the apparatus of the present invention includes an increased surface area for cellular growth preferably with a ratio of media volume per unit surface area in the range of about 0.25 – 0.50 ml/cm²; however, the dimensions and confines for cellular growth are unlimited. One such embodiment would include a height of about 2.8 mm. As stated previously, however, the height is unrestricted so long as it permits area for the growth of cells. Furthermore, by completely filling the cell growth chambers with media, the cells have access to optimal nutrient exchange.

The embodiments of the present invention may be modified to take the shape of any device, container, apparatus, vessel, or flask currently used in industry. Specifically, cylindrical or alternative vessels may utilize gas permeable substrates (internal to the vessel) in combination with tracheal chambers or spaces to provide an improved culturing environment for the growth of cells. A spiral or alternative approach inclusive of a tracheal chamber would therefore be possible. Further, although tracheal chambers may take many forms and be of any size, the passageway-like chambers are: a) confined air spaces, b) in communication with a gas permeable membrane that is permissive to cell growth, and c) communicative with the external environment via open direct access and/or additional gas permeable membranes.

As presented, the multiple embodiments of the present invention offer several improvements over standard vessels currently used in industry. The improved cell culture devices remarkably enhance the volume of cells that are capable of being cultured in the volume enclosed by traditional cell culture vessels. The various benefits are attributable to the multi-layered arrangement of gas permeable membranes assembled into a unitary vessel. Successive layering of individual growth chambers and tracheal chambers inclusive of the gas permeable membranes makes oxygen and other gases from the external environment available to the internal contents of the apparatus. Specifically, gaseous exchange with the nutrient media is conducive to an

even distribution of cell growth when gas permeable membranes are utilized on at least one potential growth surface. The cell growth apparatus is capable of fully utilizing its capacity by allowing cells access to optimal volumes of nutrient media and direct oxygenation via the tracheal spaces. Additional benefits are afforded to the cell culturing apparatus in which the exterior framework is rigidly constructed, conveniently offering easy handling, storage, and accessibility.

In one embodiment, the present invention has a footprint conforming to industry standard for microplates (5.030 +/- .010 inches by 3.365 +/- .010 inches). For this reason, the neck portion is preferably recessed within the overall rectangular footprint. The advantage of providing an apparatus with such a footprint is that automated equipment designed specifically for the manipulation of microplates may be utilized with this apparatus with very little customized modification. Similarly the height, or the distance between the outer most portion of the bottom tray and the outer portion of the top plate, is approximately 0.685 +/- .010 inches. At any rate, the present invention is not intended to be limited in any way by the aforementioned preferred dimensions and in fact may be constructed to any dimension.

As exemplified, the apparatus may include any unitary structure, vessel, device or flask with the capacity to integrally incorporate substrates in successive orientation. The invention being thus described, it would be obvious that the same may be varied in many ways by one of ordinary skill in the art having had the benefit of the present disclosure. Such variations are not regarded as a departure from the spirit and scope of the invention, and such modifications as would be obvious to one skilled in the art are intended to be included within the scope of the following claims and their legal equivalents.

IN THE CLAIMS:

1. A cell growth apparatus comprising:
a plurality of cell growth chambers, each having a gas permeable, liquid
impermeable surface and an opposing surface; and
at least one tracheal chamber in communication with at least one gas permeable,
liquid impermeable surface of at least one cell growth chamber.
2. The apparatus according to claim 1, wherein said at least one tracheal chamber
and said plurality of cell growth chambers are combined into at least one integral unit.
3. The apparatus according to claim 2, wherein each said cell growth chamber
alternates with said tracheal chamber in successive orientation.
4. The apparatus according to claim 3, whereby said cell growth chambers are
adjoined and are in communication with said tracheal chamber.
5. The cell growth apparatus of claim 2, wherein said tracheal chambers permit
gaseous exchange between said gas permeable, liquid impermeable surface of said cell
culture chamber and external atmosphere.
6. The apparatus of claim 2, said integral unit having at least one access port to
each cell growth chamber.
7. The apparatus of claim 6, wherein at least one access port includes a neck.
8. The apparatus of claim 2, further comprising a manifold to access said plurality
of cell growth chambers.
9. The cell growth apparatus of claim 2, whereby said cell growth chambers are
capable of being completely filled with media for optimal cell-nutrient exchange.

10. The cell growth apparatus of claim 2, wherein said opposing surface is gas permeable, liquid impermeable.

5 11. The cell growth apparatus of claim 2, whereby a uniformity of conditions for cellular growth includes a determined media volume per unit surface area.

12. The cell growth apparatus of claim 2, wherein one or more optical components are in communication with said cell growth chamber(s).

10 13. The cell growth apparatus of claim 2, whereby said integral unit comprises a plurality of modules.

14. The cell growth apparatus of claim 13, wherein said plurality of modules are interconnected in series or staggered to permit continuous flow.

15

15. The cell culture apparatus according to claim 2, whereby said integral unit comprises one or more supports, alone or in combination with lateral ribs.

20

16. The cell culture apparatus according to claim 2, wherein said integral unit has a substantially rectangular footprint and a substantially uniform height.

17. The cell culture apparatus according to claim 16, wherein a neck and/or cap is located within said substantially rectangular footprint and does not exceed the height of said integral unit.

25

18. The cell culture apparatus according to claim 2, further comprising stand-offs rising from an exterior surface of the top plate and/or descending from an exterior surface of the bottom tray.

19. A cell growth apparatus comprising:
at least one cell growth chamber having a gas permeable, liquid impermeable
surface and an opposing surface;
at least one tracheal space in communication with at least one gas permeable,
5 liquid impermeable surface of the at least one cell growth chamber; and
wherein the at least one tracheal space is an air chamber in communication with
the external environment and confined by an outer vessel body.

20. A method of culturing cells in said apparatus according to claim 1, the method
10 comprising:

- (a) assembly of said gas permeable substrate(s) into desired configuration,
- (b) introducing said cells and/or media into said cell culture chamber of said
flask, and
- (c) incubating said flask.

21. The method according to claim 19, further comprising a step of rotating the
15 apparatus to culture cells on an opposing surface of said gas permeable, liquid
impermeable surface.

FIG. 1A

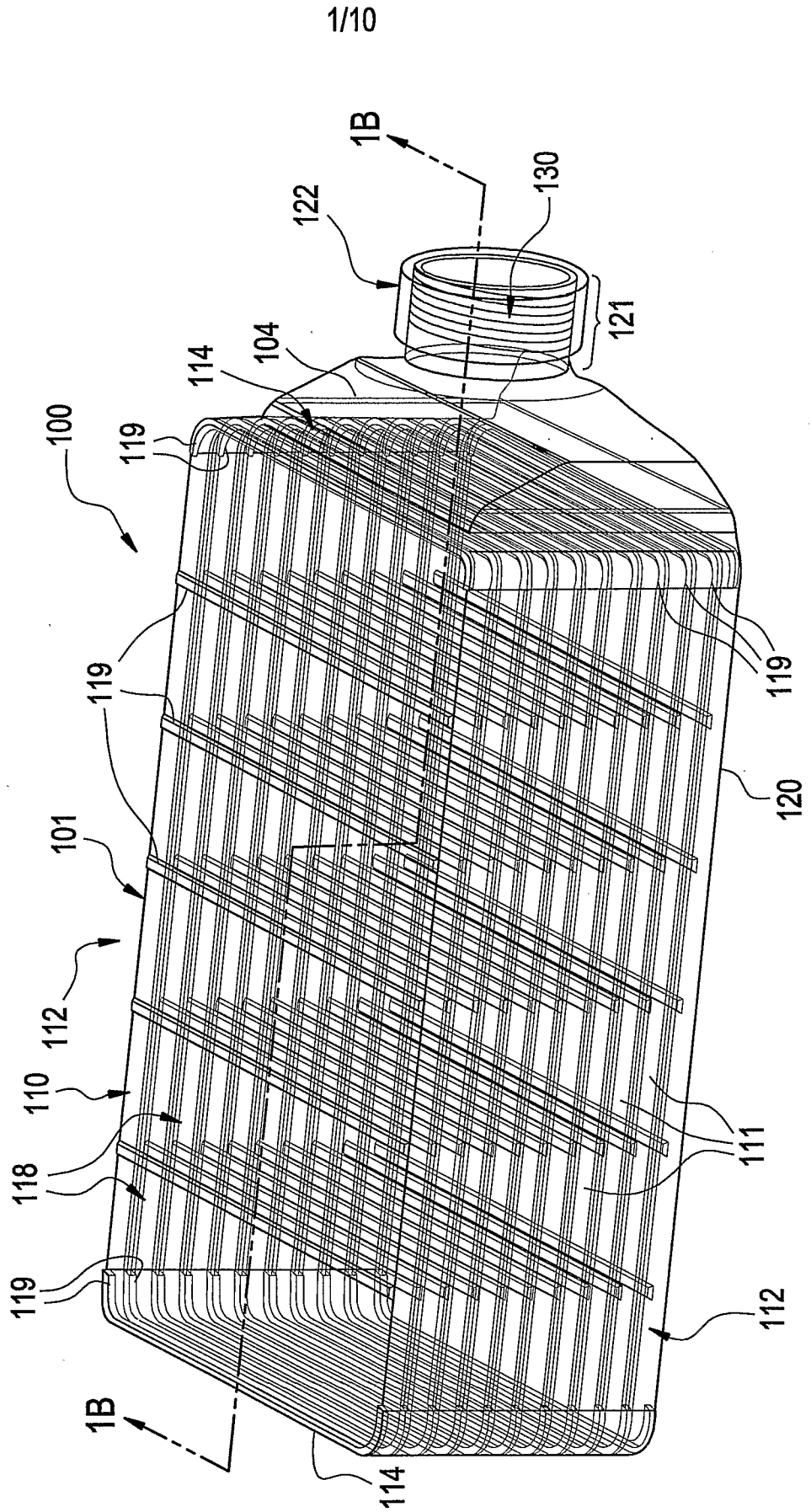

FIG. 1B

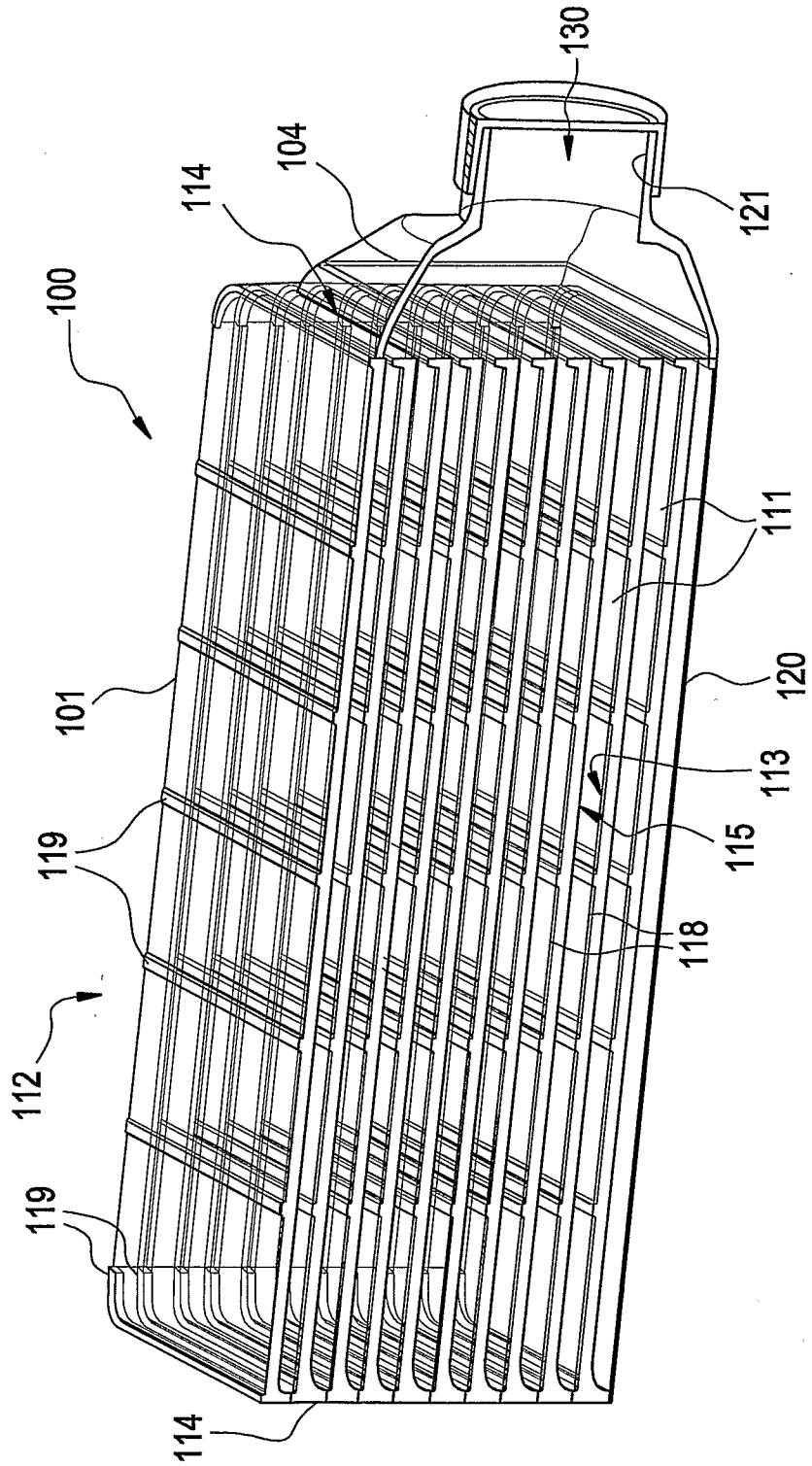

FIG. 1C

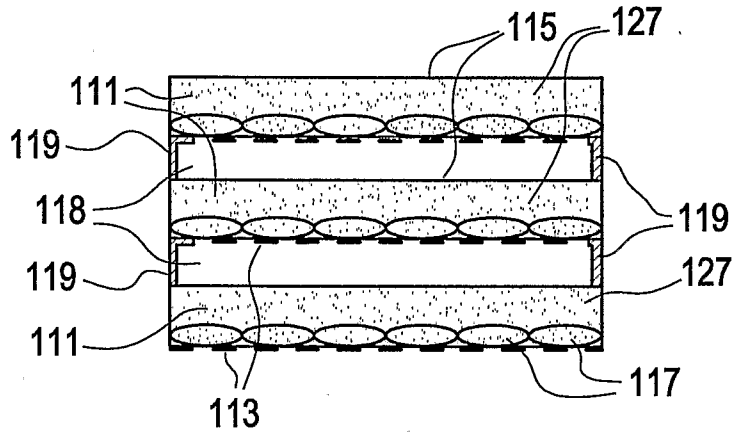

FIG. 2

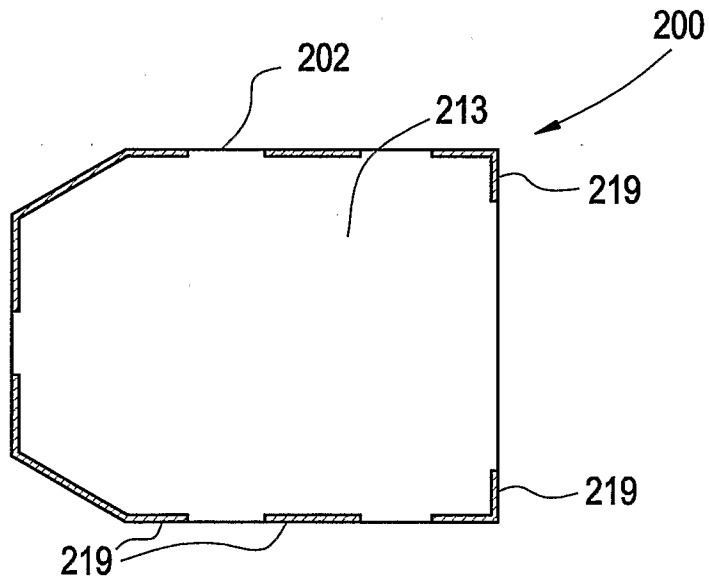

FIG. 3

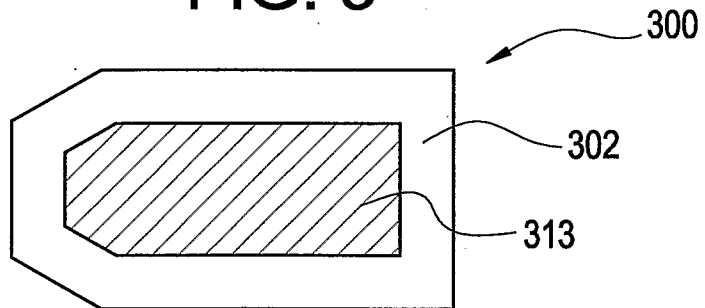
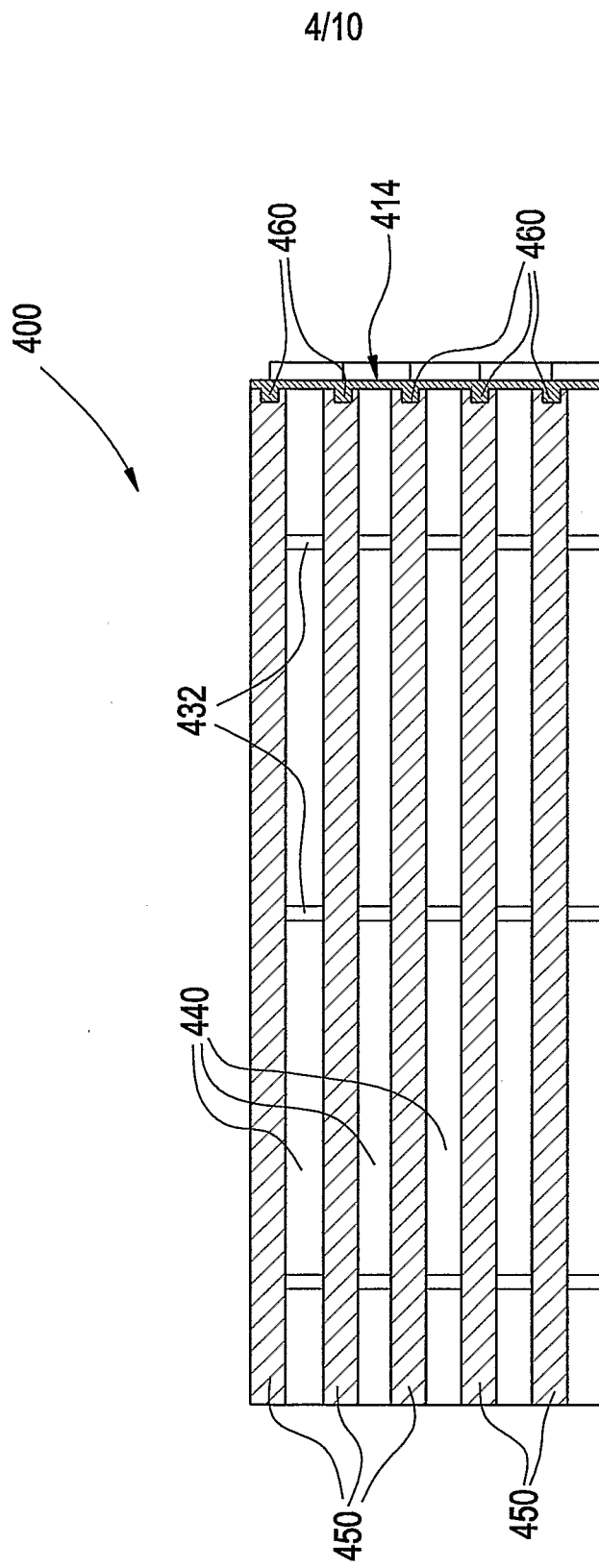
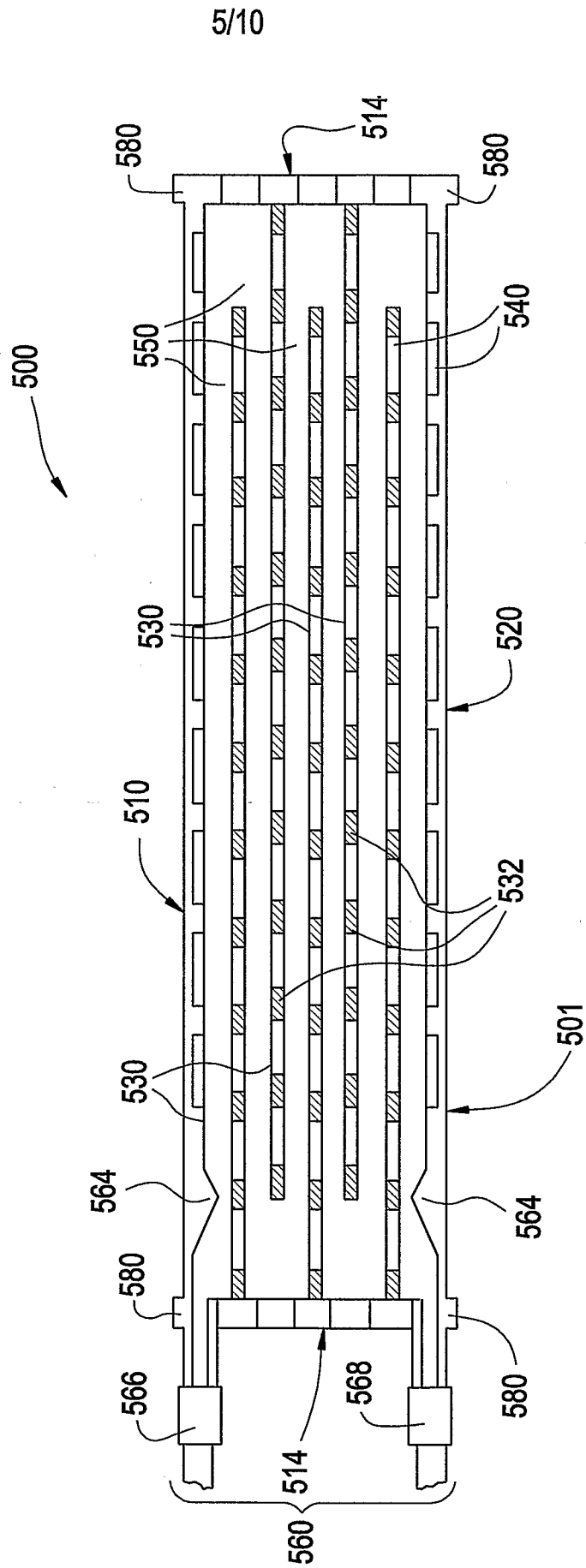

FIG. 4



4/10

FIG. 5



6/10

FIG. 5A

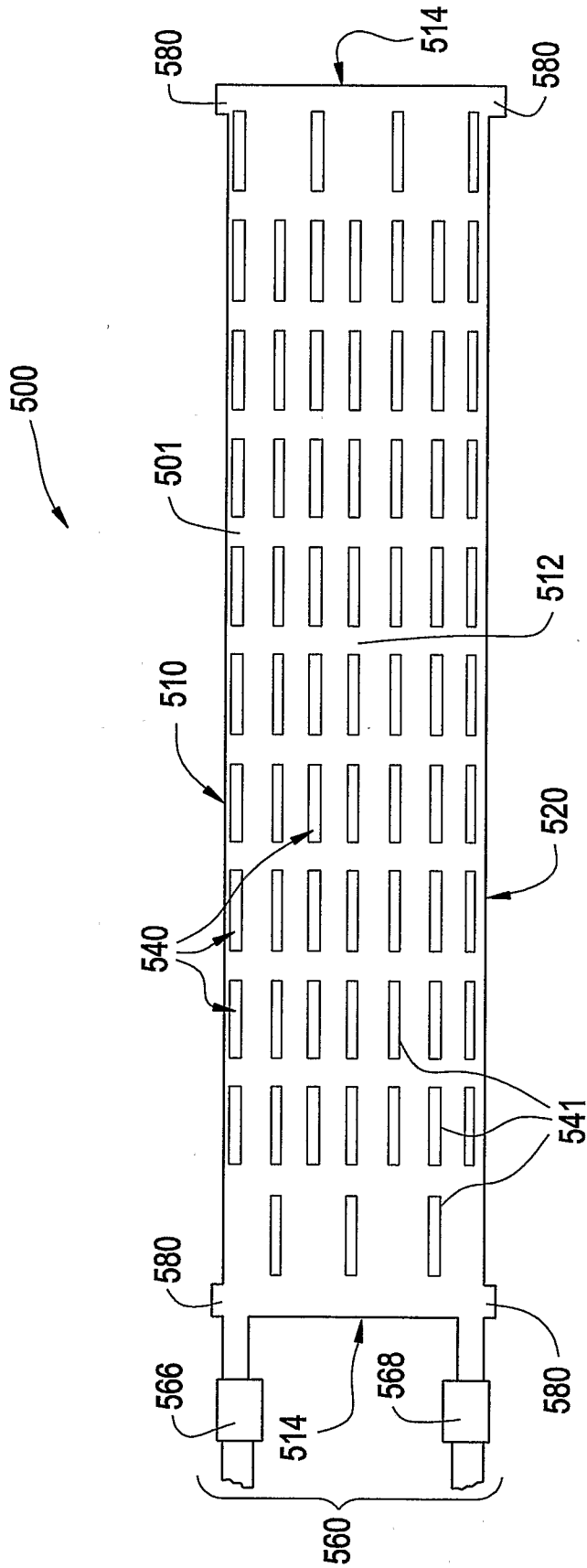

FIG. 6

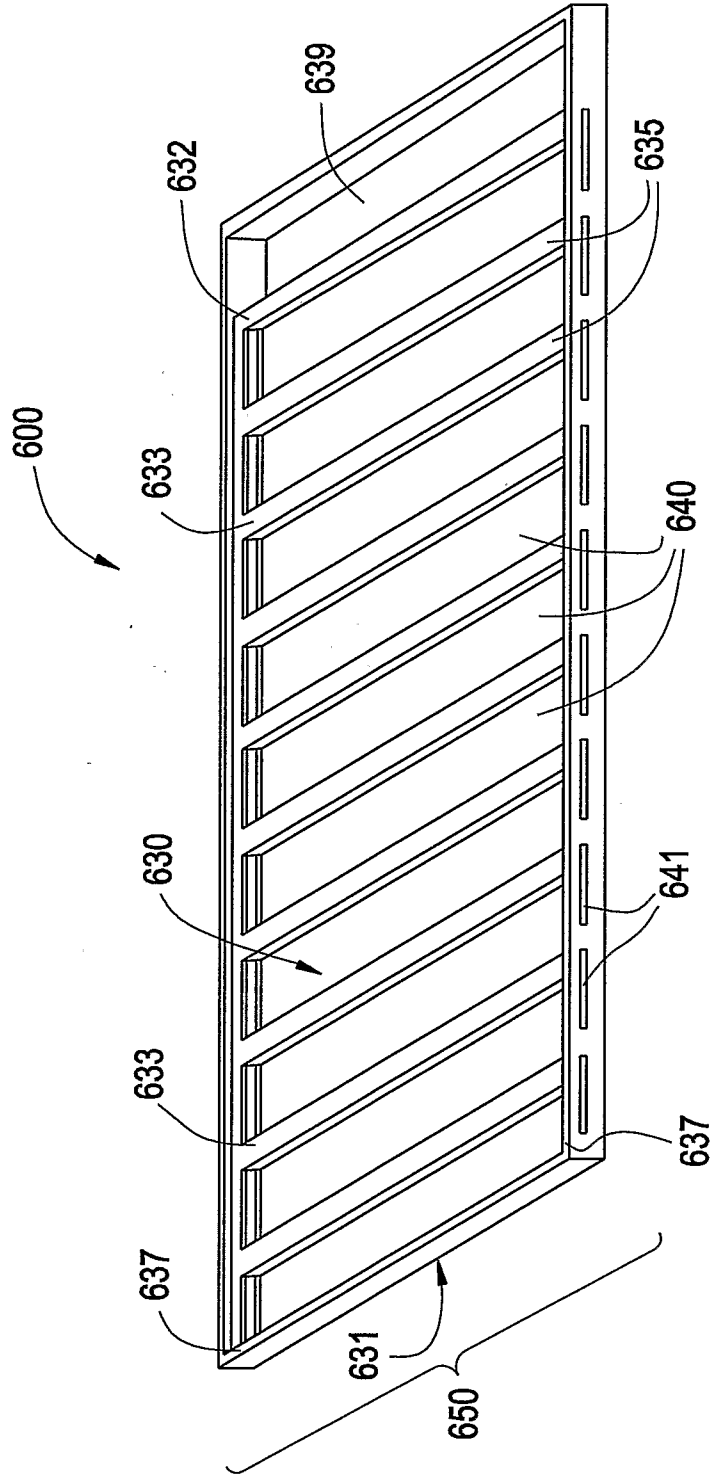

FIG. 7

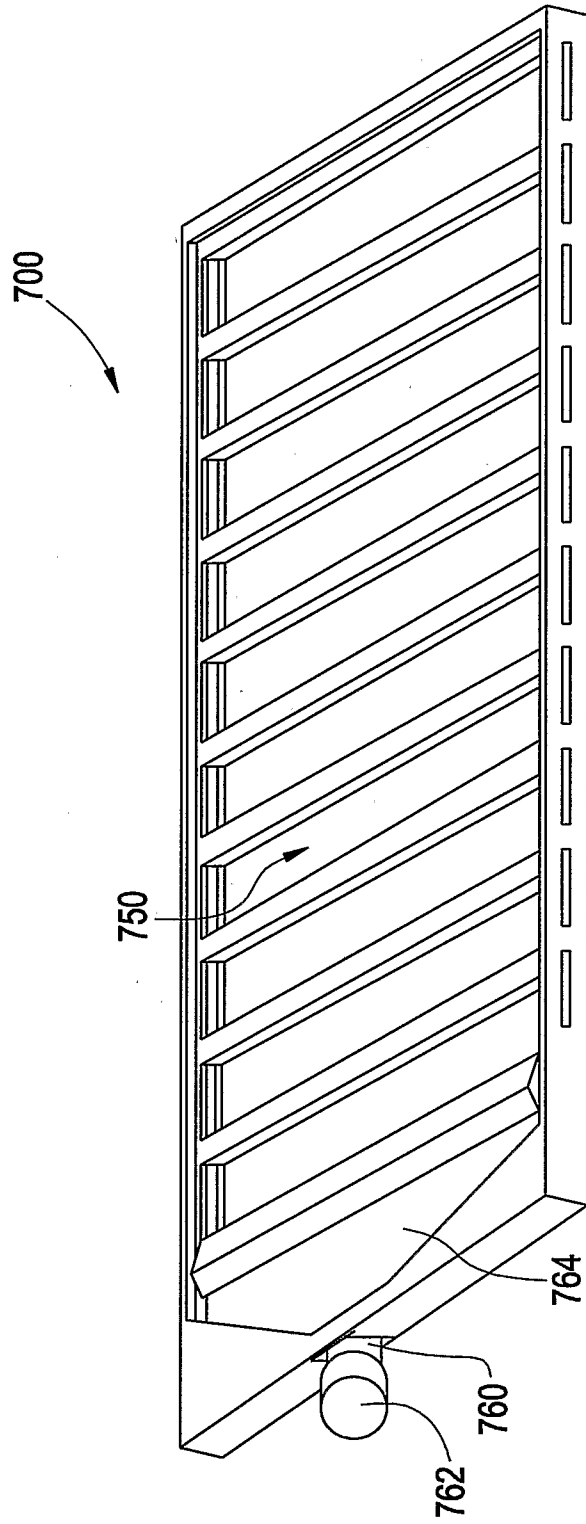

FIG. 8

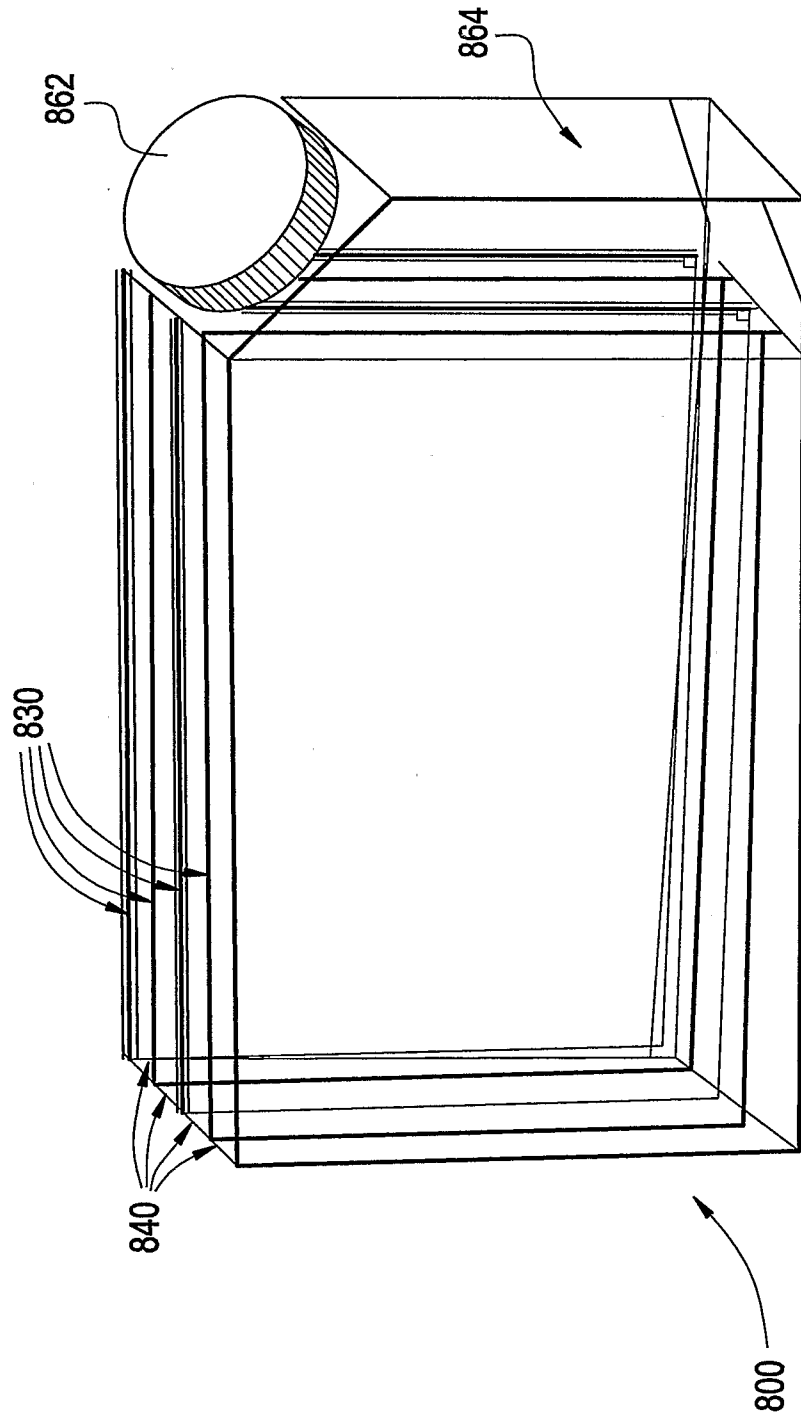
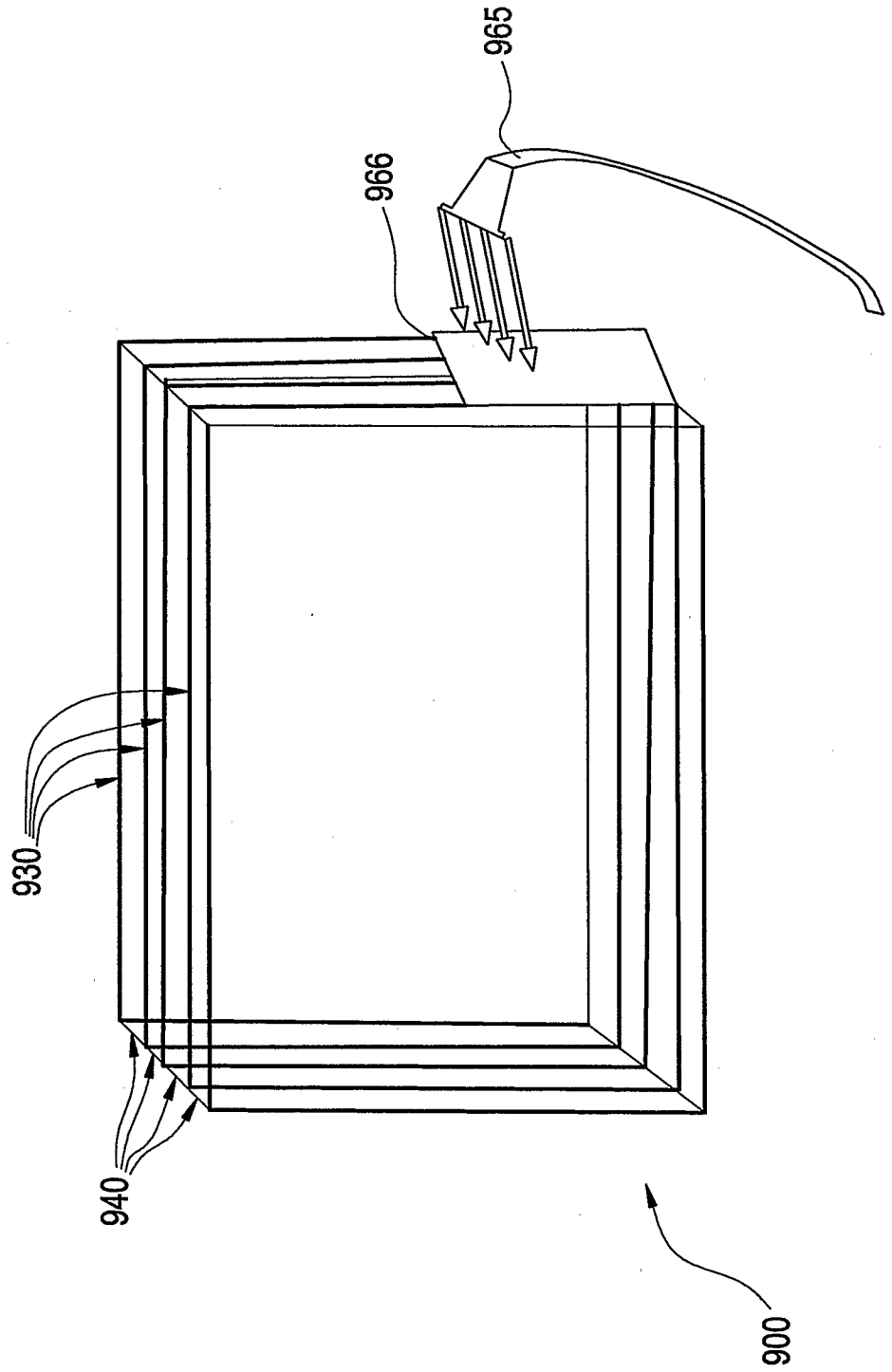

FIG. 9



INTERNATIONAL SEARCH REPORT

International application No
PCT/US2006/027475

A. CLASSIFICATION OF SUBJECT MATTER
INV. C12M3/06 B01L3/08

According to International Patent Classification (IPC) or to both national classification and IPC

B. FIELDS SEARCHED

Minimum documentation searched (classification system followed by classification symbols)
C12M C12N B01L

Documentation searched other than minimum documentation to the extent that such documents are included in the fields searched

Electronic data base consulted during the international search (name of data base and, where practical, search terms used)

EPO-Internal

C. DOCUMENTS CONSIDERED TO BE RELEVANT

| Category* | Citation of document, with indication, where appropriate, of the relevant passages | Relevant to claim No. |
|-----------|---|-----------------------|
| X | US 4 661 455 A (HUBBARD PETER J [US]) 28 April 1987 (1987-04-28) column 4, line 20 - line 50 column 5, line 25 - line 45 column 5, line 61 - column 6, line 68 figures 1-5 | 1-21 |
| X | US 4 225 671 A (PUCHINGER HERWIG ET AL) 30 September 1980 (1980-09-30) column 1, line 5 - line 14 column 3, line 62 - column 4, line 40 figures 1,2 | 1-21 |
| X | US 5 658 797 A (BADER AUGUSTINUS [DE]) 19 August 1997 (1997-08-19) column 2, line 40 - line 54 column 7, line 6 - column 9, line 8 figures 1-4 | 1-21 |

Further documents are listed in the continuation of Box C.

See patent family annex.

* Special categories of cited documents :

- "A" document defining the general state of the art which is not considered to be of particular relevance
- "E" earlier document but published on or after the international filing date
- "L" document which may throw doubts on priority claim(s) or which is cited to establish the publication date of another citation or other special reason (as specified)
- "O" document referring to an oral disclosure, use, exhibition or other means
- "P" document published prior to the international filing date but later than the priority date claimed

- "T" later document published after the international filing date or priority date and not in conflict with the application but cited to understand the principle or theory underlying the invention
- "X" document of particular relevance; the claimed invention cannot be considered novel or cannot be considered to involve an inventive step when the document is taken alone
- "Y" document of particular relevance; the claimed invention cannot be considered to involve an inventive step when the document is combined with one or more other such documents, such combination being obvious to a person skilled in the art.
- "&" document member of the same patent family

Date of the actual completion of the international search

9 November 2006

Date of mailing of the international search report

20/11/2006

Name and mailing address of the ISA/

European Patent Office, P.B. 5818 Patentlaan 2
NL - 2280 HV Rijswijk
Tel. (+31-70) 340-2040, Tx. 31 651 epo nl,
Fax: (+31-70) 340-3016

Authorized officer

Cubas Alcaraz, Jose

INTERNATIONAL SEARCH REPORT

International application No
PCT/US2006/027475

(Continuation). DOCUMENTS CONSIDERED TO BE RELEVANT

| Category* | Citation of document, with indication, where appropriate, of the relevant passages | Relevant to claim No. |
|-----------|---|-----------------------|
| X | US 6 465 252 B1 (TONER MEHMET [US] ET AL) 15 October 2002 (2002-10-15) column 2, line 35 - line 50 column 7, line 33 - line 37 figure 1 | 1-21 |
| A | ----- GB 2 268 187 A (UNIV HULL [GB]) 5 January 1994 (1994-01-05) page 4; figure 2 ----- | 1-21 |

INTERNATIONAL SEARCH REPORT

Information on patent family members

International application No

PCT/US2006/027475

| Patent document cited in search report | Publication date | Patent family member(s) | Publication date | |
|--|------------------|-------------------------|------------------|------------|
| US 4661455 | A | 28-04-1987 | AU 6743287 A | 23-07-1987 |
| | | | EP 0232975 A2 | 19-08-1987 |
| | | | JP 62228269 A | 07-10-1987 |
| US 4225671 | A | 30-09-1980 | DE 2726313 A1 | 04-01-1979 |
| | | | FR 2393849 A1 | 05-01-1979 |
| | | | GB 1567899 A | 21-05-1980 |
| | | | JP 54046892 A | 13-04-1979 |
| US 5658797 | A | 19-08-1997 | AT 131867 T | 15-01-1996 |
| | | | AU 668922 B2 | 23-05-1996 |
| | | | CA 2129648 A1 | 16-09-1993 |
| | | | DE 4206585 A1 | 09-09-1993 |
| | | | DK 629237 T3 | 09-04-1996 |
| | | | WO 9318133 A1 | 16-09-1993 |
| | | | EP 0629237 A1 | 21-12-1994 |
| | | | ES 2083851 T3 | 16-04-1996 |
| | | | GR 3019255 T3 | 30-06-1996 |
| | | | JP 3176628 B2 | 18-06-2001 |
| | | | JP 7504325 T | 18-05-1995 |
| | | | NO 943242 A | 01-09-1994 |
| | | | US 6465252 | B1 |
| US 6759245 B1 | 06-07-2004 | | | |
| GB 2268187 | A | 05-01-1994 | NONE | |