



INTERNATIONAL APPLICATION PUBLISHED UNDER THE PATENT COOPERATION TREATY (PCT)

<p>(51) International Patent Classification ⁶ : C10M 175/00</p>	<p>A1</p>	<p>(11) International Publication Number: WO 99/13033</p> <p>(43) International Publication Date: 18 March 1999 (18.03.99)</p>
<p>(21) International Application Number: PCT/US98/18537</p> <p>(22) International Filing Date: 8 September 1998 (08.09.98)</p> <p>(30) Priority Data: 08/925,279 8 September 1997 (08.09.97) US</p> <p>(71) Applicant: PROBEX CORPORATION [US/US]; Suite 111, 1467 Lemay, Carrollton, TX 75007 (US).</p> <p>(71)(72) Applicants and Inventors: DASPIT, Alexander, D., B. [US/US]; 3509 Springbrook Drive, Dallas, TX 75205 (US). MACDONALD, Martin [US/US]; Suite 433, 5945 W. Parker Road, Plano, TX 75093 (US). MURRAY, Thomas [US/US]; 184 Cooper Creek Road, Denton, TX 76208 (US).</p> <p>(74) Agents: STAVISH, Matthew et al.; Longacre & White, Suite 401, 1919 South Eads Street, Arlington, VA 22202 (US).</p>		<p>(81) Designated States: AL, AM, AT, AU, AZ, BB, BG, BR, BY, CA, CH, CN, CZ, DE, DK, EE, ES, FI, GB, GE, HU, IL, IS, JP, KE, KG, KP, KR, KZ, LK, LR, LS, LT, LU, LV, MD, MG, MK, MN, MW, MX, NO, NZ, PL, PT, RO, RU, SD, SE, SG, SI, SK, TJ, TM, TR, TT, UA, UG, UZ, VN, ARIPO patent (GH, GM, KE, LS, MW, SD, SZ, UG, ZW), Eurasian patent (AM, AZ, BY, KG, KZ, MD, RU, TJ, TM), European patent (AT, BE, CH, CY, DE, DK, ES, FI, FR, GB, GR, IE, IT, LU, MC, NL, PT, SE), OAPI patent (BF, BJ, CF, CG, CI, CM, GA, GN, GW, ML, MR, NE, SN, TD, TG).</p> <p>Published <i>With international search report.</i></p>
<p>(54) Title: METHOD OF RE-REFINING WASTE OIL BY DISTILLATION AND EXTRACTION</p>		
<p>(57) Abstract</p> <p>A process for recovering a base oil of lubricating viscosity from used oil in which, following optional pretreatment, used oil is re-refined by distilling it in distillation apparatus having multiple theoretical plates. Impurities are then extracted from the lube range distillate fraction or fractions with a liquid extractant such as N-Methyl-2-Pyrrolidone (NMP) at a temperature below the temperature, if any, of complete miscibility of the extractant and the oil. The oil and extractant are then separated whereupon the extractant is re-used in the process and the oil is subject to further treatment, as necessary, for targeted uses.</p>		

FOR THE PURPOSES OF INFORMATION ONLY

Codes used to identify States party to the PCT on the front pages of pamphlets publishing international applications under the PCT.

AL	Albania	ES	Spain	LS	Lesotho	SI	Slovenia
AM	Armenia	FI	Finland	LT	Lithuania	SK	Slovakia
AT	Austria	FR	France	LU	Luxembourg	SN	Senegal
AU	Australia	GA	Gabon	LV	Latvia	SZ	Swaziland
AZ	Azerbaijan	GB	United Kingdom	MC	Monaco	TD	Chad
BA	Bosnia and Herzegovina	GE	Georgia	MD	Republic of Moldova	TG	Togo
BB	Barbados	GH	Ghana	MG	Madagascar	TJ	Tajikistan
BE	Belgium	GN	Guinea	MK	The former Yugoslav Republic of Macedonia	TM	Turkmenistan
BF	Burkina Faso	GR	Greece	ML	Mali	TR	Turkey
BG	Bulgaria	HU	Hungary	MN	Mongolia	TT	Trinidad and Tobago
BJ	Benin	IE	Ireland	MR	Mauritania	UA	Ukraine
BR	Brazil	IL	Israel	MW	Malawi	UG	Uganda
BY	Belarus	IS	Iceland	MX	Mexico	US	United States of America
CA	Canada	IT	Italy	NE	Niger	UZ	Uzbekistan
CF	Central African Republic	JP	Japan	NL	Netherlands	VN	Viet Nam
CG	Congo	KE	Kenya	NO	Norway	YU	Yugoslavia
CH	Switzerland	KG	Kyrgyzstan	NZ	New Zealand	ZW	Zimbabwe
CI	Côte d'Ivoire	KP	Democratic People's Republic of Korea	PL	Poland		
CM	Cameroon	KR	Republic of Korea	PT	Portugal		
CN	China	KZ	Kazakstan	RO	Romania		
CU	Cuba	LC	Saint Lucia	RU	Russian Federation		
CZ	Czech Republic	LI	Liechtenstein	SD	Sudan		
DE	Germany	LK	Sri Lanka	SE	Sweden		
DK	Denmark	LR	Liberia	SG	Singapore		
EE	Estonia						

Method of Rerefining Waste Oil by Distillation and Extraction

5

Field of the Invention

This invention relates to the field of rerefining waste oils for use in lubricants and the like, and in particular to methods of rerefining waste oils to produce rerefined base oils which incorporate the steps of distillation followed by extraction of undesirable contaminants with a liquid extractant.

10

Description of the Prior Art

The prior art in this area is exemplified by US patents 4,021,333, 4,071,438, and 4,302,325. Such liquid liquid extraction finishing rerefining processes have the inherent advantage relative to alternative base oil rerefining processes of not requiring the consumption of hydrogen or clay and of not generating any voluminous or hazardous waste byproduct streams. However, such processes have heretofore had significant economic shortcomings. Because of these shortcomings, all of the prior art patents in this area have expired or are nearing expiration without having been commercialized.

15

Relative to hydrofinishing, which is the predominant rerefined base oil finishing process employed in the United States, such liquid-liquid extraction processes eliminate the requirement for hydrogen, reduce the production of environmentally problematic byproducts, eliminate the need for high temperature, high pressure operations and thus are inherently safer (presuming a relatively non-toxic extractant is used), and eliminate the need for periodic catalyst replacement and handling.

20

However, unless practiced according to the methods of this invention, such processes either require a large and uneconomic volume of solvent, which contributes to a low yield of rerefined base oil, or

0 produce a rerefined base oil of relatively low quality, which could be more simply produced via clay
finishing. Where a high quality base oil is required, these shortcomings have heretofore caused these
processes to be significantly less cost effective than hydrofinishing and accordingly have precluded
their commercial implementation, notwithstanding their inherent advantages. Moreover, unless
practiced according to the methods of this invention, such prior art processes may result in
5 unacceptable fouling of process equipment.

Objects of the Invention

Several objects and advantages of the invention are: 1) to achieve a relatively high yield of high quality
10 rerefined base oil following distillation and extraction; 2) to reduce the volume of recirculating extractant
required to produce a rerefined oil of a given quality; and 3) to reduce extractant loss at a given level
of extractant recovery system complexity as a beneficial byproduct of reducing the volume of
recirculating extractant required. A further object of the invention is to permit such efficient distillation
and extraction without unacceptable fouling of process equipment.

15 Most broadly, the object of the invention is to provide an economically attractive alternative to
hydrofinishing of rerefined oils which produces a base oil of comparable quality with few of
hydrofinishing's operational and environmental liabilities.

Summary of the Invention

20 The inventors have discovered that liquid liquid extraction finishing processes for used oil are
surprisingly sensitive to the configuration of the distillation apparatus used to fractionate the distillate
prior to finishing. Use of a distillation column with effective packing and multiple theoretical plates to
25 separate distillate from used oil prior to finishing permits a high quality rerefined oil to be finished
through liquid liquid extraction on a more cost effective basis than is possible through hydrotreating or
any other known finishing process. However, if in accordance with typical rerefining practice, loose grid
packing or a wiped film evaporator is employed for distillation prior to finishing, liquid liquid extraction

0 finishing is less economically attractive than hydrofinishing. The failure to recognize the importance of this issue has precluded successful commercialization of the prior art processes in this area notwithstanding the well developed body of knowledge on the design and construction of liquid liquid extraction units themselves, which has been perfected in the course of their application to virgin lubricant processing in solvent refining units.

5 To summarize a preferred embodiment of the process, the oil is first pretreated, employing means well known to those schooled in the art, to remove entrained water and a portion of the volatile low boiling components unsuitable for incorporation in lubricants. Preferably, this pretreatment process also incorporates thermal treatment or additive separation steps known in the art which expressly or
10 incidentally reduce used oil's propensity to foul, such as are set forth in U.S. patents 4,247,389, 4,420,389, 5,286,380, 5,306,419, or 5,556,548, the disclosures of which are incorporated herein by reference thereto.

15 The oil is then vacuum distilled in a packed column having multiple theoretical plates, equilibrium stages, or steps. The distillation apparatus employed must have more than one theoretical plate, and will preferably have more than 1½ or more than 2 theoretical plates.

20 Vacuum distillation in the aforesaid packed column separates the base oil boiling range material with an atmospheric equivalent boiling range of approximately 650° F to 1000° F from any remaining low boiling components not removed during the pretreatment process and from the heavy asphaltic components and metals which are unsuitable for incorporation in lubricants and which also tend to frustrate solvent extraction finishing. Optionally, the vacuum distillation step may concurrently segregate the lube distillate into various viscosity cuts which are separately solvent finished; however
25 it is desirable that effective fractionation with multiple theoretical plates separate even the heaviest distillate fraction from the asphaltic residue.

Following distillation, the lube fraction or fractions are routed to a countercurrent liquid liquid extractor such as a rotating disk contactor where they are contacted with an extractant such as N-Methyl-2-

0 Pyrrolidone (NMP) at a temperature below the temperature of complete miscibility of the solvent and
the oil. The extractant will ordinarily be a polar organic solvent or a mixture thereof. It should be
preferentially miscible with and thereby preferentially extract undesirable impurities, such as aromatics
and unsaturated hydrocarbons, and sulfur, nitrogen, and oxygen containing compounds, from the oil
over some range of temperatures and pressures. It should be, at the operating temperatures and
5 pressures, relatively immiscible with the primary product material base oil which is being purified.

Raffinate and extract phases are formed in the liquid liquid extractor in a manner well known to those
schooled in the art, and the polar and aromatic components of the distillate which are undesirable in
a finished base oil (including the polar and aromatic compounds), are concentrated in the extract
10 phase, leaving a relatively purified oil in the raffinate phase. Following vacuum distillation pursuant to
the methods of this invention, relatively low solvent dosages in the area of 25% to 100% solvent to oil
generally give satisfactory results, with the precise level dependent on the character of the oil, and the
finished base oil quality and yield desired. Unless distilled according to the teachings of this invention,
approximately *twice* the solvent dosage is required for comparable results.

15 Following extraction, the extraction solvent is separately stripped from the raffinate and extract phases
and recovered for reuse. The stripped raffinate, typically 90% of the original lube distillate stream, is
a finished base oil of high quality. The stripped extract, typically 10% of the original lube distillate
stream, is suitable as a fuel or for fuel blending, and may optionally be blended with the light low boiling
20 components of the oil, which have similar utility.

The invention can be more completely understood with reference to the accompanying drawing
Figure 1, which provides a schematic flow sheet of a preferred embodiment of the invention. In that
the individual underlying process units in Figure 1 are well known to those schooled in the art, they
are presented in block schematic form, without enumeration of the pumps, valves, reactors, heat
25 exchangers and other equipment which one of ordinary skill in the art will recognize are necessary
for each process unit to function.

Brief Description of the Drawing

Figure 1 is a schematic flow sheet of a preferred embodiment of the invention.

Detailed Description of the Invention

The invention is further clarified in the following example described with reference to Figure 1. Used oil first enters from storage 1 via line 2 into defouling and preflash process unit 3. Process unit 3 preferably at least partially stabilizes or separates certain additives such as zinc dialkyldithiophosphate (ZDP) and other components of the used oil which otherwise may contribute to fouling on heating and inhibit continuous operation of vacuum distillation column 6, as well as other pieces of process equipment. One mechanism for effecting this stabilization is set forth in the left part of Figure 1 of our co-pending applications serial # 08/879,973, filed June 20, 1997, entitled Batch Process for Demetallizing and Rerefining Used Oils, and, serial # 08/880,065, filed June 20, 1997, entitled Process for Demetallizing and Rerefining Used Oils, (the disclosures of which are incorporated herein by reference thereto) up to and including particulate separation system 27 and line 30. However, alternative mechanisms are acceptable, including without limitation alternative chemical and thermal treatment means such as are set forth in US Patents 4,247,389 and 4,420,389, separation of ZDP and other metallic compounds in a wiped film evaporator, as for example described in US Patent 4,101,414 or 4,941,967; their separation in conjunction with other additives by solvent extraction, as for example described in US Patent 5,286,380 and 5,556,548 or their thermal decomposition, which optionally may be integrated with the next, vacuum distillation step, as described in US Patent 5,306,419. The aforementioned treatment means typically and desirably also remove a least a portion of the water and light fuel components from the used oil, which pass from treatment unit 3 via line 4. Following separation via conventional means such as gravity separation, said water may be processed for disposal and said fuel may be used for plant operations, sold, or blended with other fuel byproducts of the process for sale as a composite fuel product.

Alternatively, although less preferably because of the attendant fouling and thus the relatively short

0 period between column turnarounds which results from processing most (used) crankcase and cutting
oils in this manner, process unit 3 may comprise only a pre-flash unit for water and light ends,
employed in conjunction with commercial anti-foulant chemicals such as Nalco / Exxon Energy
Chemicals LP dispersant 94BU260 and phosphate ester filmer EC5425A. Such chemicals, consistent
with vendor recommendations, would be injected in line 5 upstream of any furnace (not shown)
5 associated with vacuum distillation column 6, and injected in the pump around reflux loops (not shown)
normally associated with vacuum distillation column 6 at vendor recommended concentrations.
(Smaller amounts of these chemicals may also be desirable to complement the defouling treatments
described in the above paragraph.) The simplified approach described in this paragraph is most likely
to be acceptable for certain hydraulic oils or other oils which are relatively free of, or have been freed
10 of, any contaminants which may cause fouling.

Following pretreatment, the oil is sent via line 5 to vacuum distillation column 6. A furnace (not shown)
may be incorporated in line 5 prior to vacuum distillation column 6 if required to elevate the
temperature of the oil to normal vacuum distillation temperatures. Vacuum distillation column 6
15 separates via fractional distillation the lube fraction of the oil having an atmospheric equivalent boiling
range from approximately 650° F to approximately 1000° F. Contrary to the teachings of pioneer US
Patent 4,021,333, which reads in part "it is usually preferred to conduct the distillation without a
fractionation column or similar apparatus", and contrary to usual re-refining practice, it is essential
to the process of this invention that this distillation be effected in a fractionation column or other apparatus
20 with more than one theoretical plate. It will preferably have more than one and one half, or more than
two, or more than three theoretical plates.

Optionally, and not shown, the column may fractionate the lube fraction into several distinct distillation
25 range and viscosity grades, all but one of which is sent to intermediate storage at any given time, which
are then processed on a blocked out basis in counter current extractor 11 and the balance of the
apparatus. As an alternative to blocked out operations when separate viscosity grades of oil are
desired, each viscosity grade may be sent to a separate dedicated counter current extractor. Where

0 multiple viscosity grades of oil are fractionated, however, it is desirable that effective fractionation with multiple theoretical plates separate even the heaviest base oil fraction from the asphaltic residue.

A vacuum tower such as the vacuum distillation column 31 of our co-pending applications previously referenced is well suited to this application. This column is of static packed design, providing a
5 significant number of theoretical plates and relatively sharp discrimination between low and high boiling fractions; and is not of the wiped or thin film evaporator design typically employed for used oils.

Although there are a wide range of acceptable conventional design configurations for vacuum column
6, particularly preferred at this time is a packed tower employing low pressure drop structured packing or a combination of random packing in the lower portion of the column and structured packing in the
10 upper portion, and with all lube distillate extracted as a single side stream into line 9 so that it can be immediately routed to a single finishing train. To further reduce the risk of fouling in this column it is desirable to have generous pumped reflux (not shown) to spray incipient fouling downward into the residuum from the packed sections.

15 Vacuum distillation column 6 will ordinarily incidentally separate a heavy residue stream with an atmospheric equivalent boiling range primarily above 1000° F, which passes through line 8, and may also separate any remaining light byproduct with an atmospheric equivalent boiling range primarily below 650° F, which passes through line 7. The light byproduct may be sold as fuel, blended and sold
20 with other byproducts of the process or other fuels as a composite fuel, or applied in any other economically attractive basis. The heavy byproduct may be sold or used as an asphalt extender, or as fuel or fuel blending component.

Following vacuum distillation column 6, the lube fraction or fractions are routed via line 9 through
25 cooler 10 to liquid liquid extractor 11, wherein they are contacted with a liquid liquid extractant such as N-Methyl-2-Pyrrolidone (NMP), furfural, or phenol, or suitable extractant mixtures, such as NMP with up to 1% water, at a temperature below the temperature of complete miscibility of the extractant and

0 the oil. NMP is the preferred extractant, and extraction temperatures in the area of 100F to 150F have been found therewith to give good results. NMP dosages in the area of 25% to 100% of the oil by volume are preferred, but lower or higher amounts may be used if desired, depending on the quality of the finished end product desired. Contrary to the teachings of US Patent 4,071,438, which teaches contacting in a single stage mixer settler, liquid liquid extraction apparatus with multiple theoretical stages such as a packed column, rotating disk contactor, or Podbielniak extractor (or two or more Podbielniak extractors in series) are strongly preferred. Alternatively, multiple sequential mixer settler stages may be employed. Further contrary to the teachings of US patent 4,071,438, nitrobenzene is an unattractive extraction solvent in light of its toxicity.

10 The density difference between the extract and raffinate phases is typically low when low solvent dosages such as are effective in the present invention are employed. Accordingly, it may be desirable when employing a countercurrent extractor wherein the phases contact by gravity (as distinct from a Podbielniak extractor or similar multistage centrifugal extractors) to operate the extraction step with a higher dry (that is, without water) solvent dosage effective for rapid separation of the two liquid phases of the extraction tower, and reflux the extraction tower by the introduction of water or wet solvent near the point of withdrawal of the extract phase towards the bottom of the extractor.

15 Following extractor 11, the raffinate phase, typically comprising 90% of the oil and 10% of the solvent, passes through line 12 to raffinate solvent recovery unit 14, where it is stripped of the minor amounts of solvent and any water therein, and the solvent itself is stripped of any water therein (although optionally a small amount of water, such as 1%, may be retained in the solvent if desired, and such minor amounts are known, in the case of NMP, to improve its selectivity). Similarly, the extract phase, typically comprising 90% of the solvent and 10% of the oil, passes through line 13 to extract solvent recovery unit 15, where it is stripped of its solvent and excess water. The solvent from solvent recovery units 14 and 15, stripped of water to the desired level, is thereafter collected, and passes through lines 18, 19, and 20 for reuse in countercurrent extractor 11. Small volumes of makeup solvent may be added periodically to the system as needed to compensate for unavoidable minor solvent decomposition or loss.

0 Solvent recovery units 14 and 15 will preferably be one or two stage distillation units with steam, ammonia, or inert gas stripping in the final or only stage. A reasonable configuration is to employ one stage solvent recovery under vacuum with inert stripping for the raffinate phase, and two stage solvent recovery, the first under slight positive pressure and the second under vacuum with inert gas stripping, to remove the heavier solvent load from the extract phase. The solvent recovery units may optionally

5 be of designs developed for NMP recovery in virgin lube oil solvent refining units, such as are set forth in US patents 3,461,066, 4,057,491, 4,294,689, 4,342,646, 4,390,418, and 4,419,227; the disclosures of which are herein incorporated by reference. However, in light of the generally smaller proportion of solvent required to achieve satisfactory results in the process of the current invention, elaborate multiple effect solvent recovery schemes are generally not required. Reasonable thermal efficiencies can normally be achieved with one or two recovery stages, particularly if heat integration is practiced

10 with the balance of the processing system, for example by employing the heat released by the oil as it is cooled from vacuum distillation column 6 (which typically would operate at absolute temperatures above 600F) to the preferred extraction temperature to at least partially heat the raffinate and extract phases to a solvent recovery temperature.

15 Following stripping of the solvent, the raffinate becomes a finished base oil suitable for sale as such, or for post finishing fractionation into different viscosity grades, and/or for compounding with additives to make a finished lubricating oil. Optionally, additional processing steps may be employed such as hydrotreating or clay finishing, or the oil may be further treated between vacuum distillation column 6 and countercurrent extractor 11, but such additional treatments are generally not required in the

20 process of the present invention.

25 Following stripping of the solvent, the extract is suitable for use as an industrial fuel or for blending with other byproducts of the process or other fuels to make a composite fuel. Alternatively, the extract may first be cooled and/or treated with an anti-solvent such as water and placed in a temporary holding tank to cause a secondary raffinate of intermediate quality to rise to the surface, which secondary raffinate, after water stripping if required, can be returned with the lube fraction feed to primary extractor 11 to improve the overall yield of the process. Alternatively, the secondary raffinate can be separately

0 stripped of solvent and water to make a lube stock of intermediate quality.

The following examples illustrate the improvement achieved from the practice of this invention. Color is used as an index of base oil product quality, however, other indicia of product quality are expected to be similarly affected, such as viscosity index, polynuclear aromatic content, and thermal and color
5 stability.

Example 1

This example illustrates the process of the present invention. A sample of used oil was prepared
10 essentially as provided in our previously referenced co-pending applications, Example 1, through vacuum distillation Stage 3, which is effected in a packed column. Specifically, substantially the following procedure was employed.

500 grams of 18-46-0 DAP fertilizer pellets were ground to a fine powder in a Krups type 203
15 household coffee mill. The powder was then mixed in a two liter Pyrex beaker with 1.6 liters of tap water and the mixture heated to 130° F (54° C) on a stirring hot plate and magnetically stirred at that temperature for 15 minutes. The stir bar was then removed and the mixture allowed to settle for 48 hours, during which it separated into a dark brown liquid and a light brown mud like residue. The dark brown liquid was retained for use as an aqueous reagent in the demetallization phase of the rerefining
20 process.

2,750 ml. of used oil obtained from a wholesale supplier was introduced into a 4 liter pyrex reaction kettle and vigorously stirred with a propeller mixer introduced through the middle kettle aperture as the mantle was electrically heated. The oil contained approximately 3% water by distillation and 0.5% ash
25 by ASTM D-482, and was opaque. The temperature of the oil was continuously monitored through one of the three side kettle apertures. A second side aperture was connected to a condenser apparatus to condense and collect overhead vapors, which condensate was maintained separately from the oil. Once the temperature of the oil reached 190° F (88° C), 96 ml. of the reagent prepared in Step 0 above

0 was added through the third side aperture, after which that aperture was sealed. Full electric heating was continued to 220° F (104° C), then suspended for 15 minutes to slow the temperature ramp and allow formation of larger particulate, and then resumed until the temperature reading was 280° F (138° C). The oil temperature continued to rise to about 300° F (149° C) due to the warmth of the mantle and then stabilized. The oil was maintained at about 300° F (149° C) under vigorous agitation for another
5 15 minutes, after which the apparatus was disassembled and the oil was decanted into a four liter Erlenmeyer flask. The separated condensate was examined and found to be comprised primarily of amber water with a thin layer of hydrocarbons floating thereon.

10 A three inch magnetic stir bar was then inserted into the four liter Erlenmeyer flask containing the decanted oil, a moderate rate of stirring was initiated, and the flask was heated to 630° F (332° C) on a twelve inch stirring hot plate, under a continuous gradual nitrogen purge administered to the side fitting of a ground glass connecting tube with side gas fitting (Corning 9420-24) placed in the neck of the flask. Overhead vapors were condensed and collected separately from the oil. The oil temperature was continuously monitored via an infrared thermometer and maintained in a range from
15 about 610° F (321° C) to 650° F (343° C) for one hour. The flask was then removed from the hot plate without cooling and placed immediately into a custom fitted cloth insulating jacket, while continuing the nitrogen purge.

20 The flask was placed immediately into a 2 ft. by 2 ft. by 3 ft. vertical acrylic glove box with a slotted door permitting continuation of the nitrogen purge. Pre-positioned in the glove box was a 10½ inch 304 stainless steel Buchner funnel resting on a 4 liter Pyrex filter flask and under vacuum. The Buchner funnel had been prepared with 97 grams of Celatom FP-4 diatomaceous earth filter aid resting on a 24 cm. disk of Whatman #1 filter paper. The glove box was loosely sealed and a vigorous nitrogen flush of the glove box was initiated through four nitrogen feed lines until the measured oxygen
25 percentage in the box, as measured on a GC Industries GC 501 Oxygen monitor, declined to 0.00% O₂. At this point the nitrogen flush to the box was reduced to a level just sufficient to maintain positive pressure and, using the box gloves, the ground glass connecting tube which had fed the nitrogen purge to the flask was removed and the contents of the flask were poured into the Buchner funnel. Filtration

0 was substantially complete in less than one minute.

Overall, this preprocessing was undertaken both to substantially demetallize the used oil and to make it susceptible to vacuum distillation in a conventional packed column with a greatly diminished risk of fouling relative to untreated used oil. It is illustrative of one of several types of optional preprocessing that may be employed with the methods of this invention. After filtration, the oil contained between 5 0.005% and 0.008% ash (as measured on different iterations of this experiment), but it remained dark in color. It was suitable only as a fuel, and not for reuse as base oil without additional processing.

The filtrate was then combined with the condensed overheads collected separately while the oil had 10 been heated in the Erlenmeyer flask and placed in a five liter vacuum distillation flask and distilled under approximately 2 mm Hg crossbar vacuum through a 19 inch long two inch diameter distillation column packed with 6mm porcelain Berl Saddles and insulated with several layers of heavy duty aluminum foil. Heating was via upper and lower electric mantles applied to the distillation flasks and controlled via a variable transformer to maintain pot pressure below 15 mm Hg and thus preclude the possibility of column flooding. The oil distilling in the fuel distillation range up to 650° F (343° C) 15 atmospheric equivalent (or up to 320° F (160° C) at 2 mm Hg), was collected and set aside, and a new collection flask mounted, taking care to maintain vacuum throughout to prevent oxygen damage to the oil. Distillation was continued until the flask temperature had reached 680° F (360° C), at which point the crossbar temperature had reached 850° F (454° C) atmospheric equivalent (480° F (249° C) at 20 mm). A somewhat higher atmospheric equivalent maximum distillation temperature can be anticipated from a production scale vacuum tower. The distillation receiver containing the base lube distillate was then removed.

Four sequential extraction stages were then employed on a portion of the base lube distillate. In Stage 25 1, 300ml of the vacuum distillate was continuously mixed in a beaker on a stirring hot plate with 75ml (25%) NMP as the mixture was heated to approximately 130F. The mixture was then poured into a separatory funnel, and allowed to cool to approximately 120F, which temperature was maintained as required with an electric forced air heat gun as separate extract and raffinate phases formed. The

0 extract phase was drawn off the bottom of the funnel and set aside for later solvent recovery and
extract separation, and the upper raffinate phase was retained for Stage 2. In Stage 2 the process was
repeated with an additional 75 ml of NMP, employing the Stage 1 raffinate in place of the original
distillate. After a total of four such stages, the final raffinate was transferred to a 2 liter round bottom
flask, heated with upper lower electric mantles, maintained at 20" Hg vacuum, and stripped with a
5 continuous nitrogen purge through a 25mm diameter column packed with 19 cm of 6mm ceramic berl
saddles. Once the crossbar temperature reached 160C, heating was stopped, and the oil, now
stripped of residual NMP, was cooled and the vacuum and nitrogen purge stopped. (A similar
apparatus and process can be employed for separation of solvent from the extract phase.) As a final
purification step unnecessary in a production configuration, the sample was filtered through two disks
10 of Whatman #2 and one of Whatman #5 filter paper to remove silicon joint grease, dust and any other
extraneous contaminants. The sample was then submitted to an independent laboratory for testing,
with the following results:

15 Viscosity @ 40° C (ASTM D445)	31.02 cst
Color (ASTM D1500)	<1.5

Example 2

20 This example illustrates the relatively poor quality of oil, as reflected in ASTM D1500 Color, achieved
employing the prior art method of US patent 4,021,333 at a similar solvent dosage to Example 1,
above. 1500 ml of used oil similar to that employed in Example 1 was placed directly in a five liter
vacuum distillation flask and distilled under approximately 2 mm Hg crossbar vacuum through a 19
inch long approximately two inch diameter column insulated with several layers of heavy duty
aluminum foil but **without packing**. Distillation was continued to approximately the distillation
25 temperatures employed in Example 1, above. 300ml of distillate was then finished employing the
same four stage sequential extraction procedure followed by stripping set forth in Example 1, above.
As in Example 1, 75 ml (25%) of NMP was employed at each stage. The final, stripped, filtered,
product was then submitted to an independent laboratory for testing, with the following results:

0 Viscosity @ 40° C (ASTM D445) 32.71 cst
 Color (ASTM D1500) <2.5

Example 3

5 This example illustrates the increased solvent dosage required to achieve a comparable quality of oil,
 as reflected in ASTM D1500 Color, to the oil of Example 1, employing the prior art method of Example
 2. 1000 ml of used oil similar to that employed in Examples 1 and 2 was placed directly in a five liter
 vacuum distillation flask and distilled under approximately 2 mm Hg crossbar vacuum through a 19
 inch long approximately two inch diameter column insulated with several layers of heavy duty
10 aluminum foil but **without packing**, as in Example 2. Distillation was continued to approximately the
 distillation temperatures employed in Examples 1 and 2, above. 300ml of distillate was then finished
 employing the same four stage sequential extraction procedure followed by stripping employed in
 Examples 1 and 2, above. However, in the present instance, 150 ml (50%) of NMP was employed at
 each stage, *twice* the amount employed in Examples 1 and 2, above. The final, stripped, filtered,
15 product was then submitted to an independent laboratory for testing, with the following results:

 Viscosity @ 40° C (ASTM D445) 32.69 cst
 Color (ASTM D1500) <1.5

20 The results in the current Example 3 are only comparable to and no better than the results achieved
 in Example 1, which employs the methods of the current invention, notwithstanding the doubling of
 solvent dosage in the present example, which does not.

 The 50% reduction in solvent dosage achievable in accordance with the practice of the current
25 invention is of great commercial significance. Operating and capital costs are both markedly reduced.

 The major variable costs of operating a solvent extraction finishing unit are the cost of fuel for solvent
 recovery and the cost of solvent makeup for solvent losses. These in turn are at least directly
 proportional to the required solvent dosage at a given level of design complexity (number of solvent
30 recovery stages, stripping column design, etc.). Indeed, given that a significant portion of initial thermal

0 requirements in an efficient plant design can be met through heat integration with earlier process units, fuel consumption may decline *more than 50%* if the required solvent dosage is cut in half. Accordingly, a 50% reduction in required solvent dosage approximately *halves* the variable cost of operating a solvent extraction finishing unit.

5 A significant reduction in capital costs, on the order of 20%, can also be anticipated at a given level of design complexity as the result of halving the required solvent dosage. The size and capital cost of the countercurrent extractors and all solvent recovery systems, including pumps, heaters, and columns, are reduced at lowered solvent dosages.

10 When employing the methods of the current invention, rerefined base oil generally comparable in overall quality to hydrotreated base oil is readily achievable, at moderate solvent dosages less than or equal to 100% extractant to feed, when a multistage liquid liquid extractor is employed. For example, an ASTM D-1500 color of less than 1.0 is routinely achievable with a high degree of color stability on lighter base oil fractions of less than 200 SUS viscosity at 100° F. Moreover, rerefining according to
15 the means of the current invention is particularly effective in reducing the polynuclear aromatic content of used oils, with levels (IP346 basis) of less than 0.5%, which are difficult to achieve via hydrotreating, easily achievable.

20 Just as importantly, and in contrast to prior art methods of liquid liquid extraction finishing applied to rerefining, engineering studies indicate that the present innovative process is substantially more economically attractive than hydrofinishing, with total direct operating cost for all equipment downstream of the distillation unit, (including maintenance and depreciation, but excluding labor, which should be comparable in either case) projected to be less than 50% of a typical rerefining hydrotreatment unit and a return on investment that is ten to fifteen percentage points higher over a
25 wide range of base oil price assumptions.

Although the invention has been described in terms of the preferred and alternative embodiments disclosed herein, those skilled in the art will appreciate many variations, modifications and

0 enhancements which fall within the spirit and scope of the invention as defined in the claims appended hereto. All such modifications and enhancements are intended to be included within the scope of the claims appended hereto.

What is claimed is:

1. A process for recovering base oil of lubricating viscosity from used oil, said process comprising the steps of:
 - 5 distilling said used oil in distillation apparatus having more than one theoretical plate to give at least one distillate fraction and a bottoms fraction;
 - extracting impurities from said at least one distillate fraction with a liquid extractant;
 - removing at least a major portion of said liquid extractant, and impurities dissolved therein, from said distillate.
- 10 2. A process according to claim 1 wherein said liquid extractant comprises a polar organic solvent.
3. A process according to claim 2 wherein said polar organic solvent comprises N-Methyl-2-Pyrrolidone.
4. A process according to claim 1 wherein said distillation step is carried out in a column under reduced pressure.
- 15 5. A process according to claim 4 comprising the additional step of initially pretreating said used oil prior to said distillation step to remove a forecut having a distillation range less than that of lubricating oil and to reduce its propensity to foul.
6. A process according to claim 1 wherein said distillation apparatus has more than one and one half theoretical plates.
- 20 7. A process according to claim 6 wherein said liquid extractant comprises a polar organic solvent.
8. A process according to claim 7 wherein said liquid extractant comprises N-Methyl-2-Pyrrolidone.
9. A process according to claim 6 wherein said distillation step is carried out in a column under reduced pressure.
10. A process according to claim 9 comprising the additional step of initially pretreating said used oil prior to said distillation step to remove a forecut having a distillation range less than that of lubricating oil and to reduce its propensity to foul.
- 25 11. A process according to claim 1 wherein said distillation apparatus has more than two theoretical plates.

0 12. A process according to claim 11 wherein said liquid extractant comprises a polar organic solvent.

13. A process according to claim 12 wherein said polar organic solvent comprises N-Methyl-2-Pyrrolidone.

14. A process according to claim 11 wherein said distillation step is carried out in a column under reduced pressure.

5 15. A process according to claim 14 comprising the additional step of initially pretreating said used oil prior to said distillation step to remove a forecut having a distillation range less than that of lubricating oil and to reduce its propensity to foul.

16. A process according to claim 1 wherein said distillation apparatus has more than one theoretical plate for separating the bottoms fraction from the heaviest distillate fraction from which impurities are extracted using said liquid extractant.

10 17. A process according to claim 16 wherein said liquid extractant comprises a polar organic solvent.

18. A process according to claim 16 wherein said liquid extractant is N-Methyl-2-Pyrrolidone.

19. A process according to claim 16 wherein said distillation step is carried out in a column under reduced pressure.

15 20. A process according to claim 16 comprising the additional step of initially pretreating said used oil prior to said distillation step to remove a forecut having a distillation range less than that of lubricating oil and to reduce its propensity to foul.

21. A process according to claim 1 wherein said distillation apparatus has more than one and one half theoretical plates for separating the bottoms fraction from the heaviest distillate fraction from which impurities are extracted using said liquid extractant.

20 22. A process according to claim 21 wherein said liquid extractant comprises a polar organic solvent.

23. A process according to claim 21 wherein said liquid extractant is N-Methyl-2-Pyrrolidone.

24. A process according to claim 21 wherein said distillation step is carried out in a column under reduced pressure.

25 25. A process according to claim 21 comprising the additional step of initially pretreating said used oil prior to said distillation step to remove a forecut having a distillation range less than that of lubricating oil and to reduce its propensity to foul.

26. A process according to claim 1 wherein said distillation apparatus has more than two theoretical

0 plates for separating the bottoms fraction from the heaviest distillate fraction from which impurities are extracted using said liquid extractant.

27. A process according to claim 26 wherein said liquid extractant comprises a polar organic solvent.

28. A process according to claim 26 wherein said liquid extractant is N-Methyl-2-Pyrrolidone.

29. A process according to claim 26 wherein said distillation step is carried out in a column under
5 reduced pressure.

30. A process according to claim 26 comprising the additional step of initially pretreating said used oil prior to said distillation step to remove a forecut having a distillation range less than that of lubricating oil and to reduce its propensity to foul

31. A process for recovering base oil of lubricating viscosity from used oil containing impurities, said
10 process comprising the steps of:

pretreating said used oil to substantially remove entrained water, volatile low boiling point components, and fouling agents, from said used oil,

distilling said used oil in a packed column having at least one theoretical plate to separate said used oil into at least two fractions, a first fraction being a bottoms fraction unsuitable for lubricants
15 comprising asphaltic residues, high boiling point components, and metals, and a second fraction being a distillate fraction having a boiling range of 650 degree F to 1000 degrees F,

extracting impurities from said used oil in a liquid liquid extractor using a liquid extractant at a
temperature below the temperature of complete miscibility of said liquid extractant and said used oil and dissolving said impurities remaining in said used oil into said liquid extractant,

20 separating said mixture of extractant and used oil into a raffinate phase and an extract phase, and, stripping said extractant and dissolved impurities from said raffinate phase to produce said recovered base oil.

32. A process according to claim 31 wherein said distillation apparatus has more than one and one
half theoretical plates.

25 33. A process according to claim 31 wherein said liquid extractant comprises a polar organic solvent.

34. A process according to claim 33 wherein said liquid extractant comprises N-Methyl-2-Pyrrolidone.

35. A process according to claim 31 wherein said distillation step is carried out in a packed column
under reduced pressure.

0

36. A process according to claim 31 wherein said distillation apparatus has more than two theoretical plates.

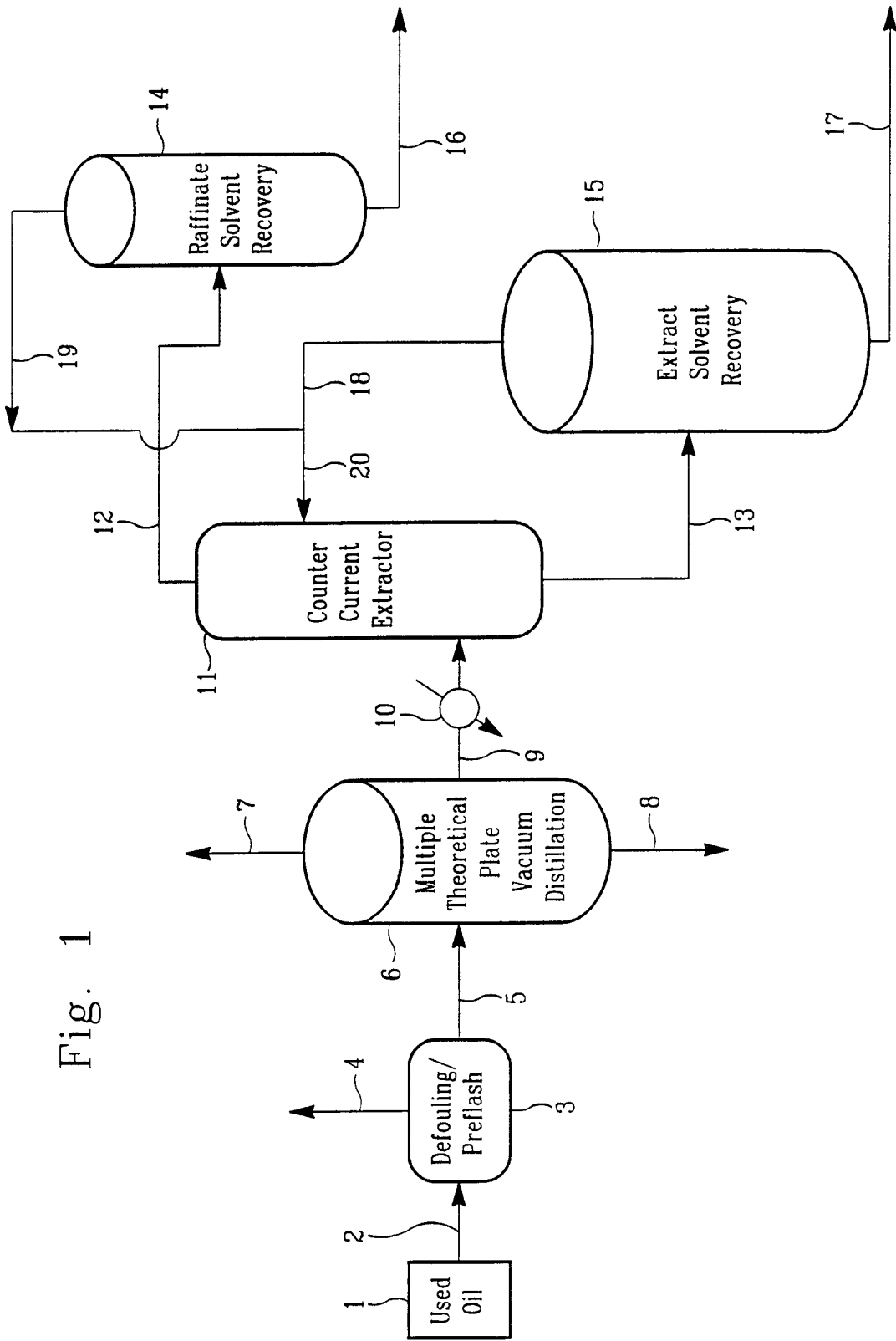

Fig. 1

INTERNATIONAL SEARCH REPORT

International Application No

PCT/US 98/18537

A. CLASSIFICATION OF SUBJECT MATTER

IPC 6 C10M175/00

According to International Patent Classification (IPC) or to both national classification and IPC

B. FIELDS SEARCHED

Minimum documentation searched (classification system followed by classification symbols)

IPC 6 C10M C10G

Documentation searched other than minimum documentation to the extent that such documents are included in the fields searched

Electronic data base consulted during the international search (name of data base and, where practical, search terms used)

C. DOCUMENTS CONSIDERED TO BE RELEVANT

Category *	Citation of document, with indication, where appropriate, of the relevant passages	Relevant to claim No.
X	US 4 071 438 A (R.H. O'BLASNY) 31 January 1978 cited in the application	1, 2, 4-7, 9-12, 14-17, 19-22, 24-27, 29-33, 35, 36
Y	see the whole document	3, 13, 18, 23, 28, 34
Y	--- US 4 021 333 A (E. NAJIB HABIBY) 3 May 1977 cited in the application see column 4; example 2 see claims 1,5 ---	3, 13, 18, 23, 28, 34
-/--		

Further documents are listed in the continuation of box C.

Patent family members are listed in annex.

* Special categories of cited documents :

- "A" document defining the general state of the art which is not considered to be of particular relevance
- "E" earlier document but published on or after the international filing date
- "L" document which may throw doubts on priority claim(s) or which is cited to establish the publication date of another citation or other special reason (as specified)
- "O" document referring to an oral disclosure, use, exhibition or other means
- "P" document published prior to the international filing date but later than the priority date claimed

- "T" later document published after the international filing date or priority date and not in conflict with the application but cited to understand the principle or theory underlying the invention
- "X" document of particular relevance; the claimed invention cannot be considered novel or cannot be considered to involve an inventive step when the document is taken alone
- "Y" document of particular relevance; the claimed invention cannot be considered to involve an inventive step when the document is combined with one or more other such documents, such combination being obvious to a person skilled in the art.
- "&" document member of the same patent family

Date of the actual completion of the international search 16 December 1998	Date of mailing of the international search report 30/12/1998
Name and mailing address of the ISA European Patent Office, P.B. 5818 Patentlaan 2 NL - 2280 HV Rijswijk Tel. (+31-70) 340-2040, Tx. 31 651 epo nl, Fax: (+31-70) 340-3016	Authorized officer Hilgenga, K

INTERNATIONAL SEARCH REPORT

International Application No
PCT/US 98/18537

C.(Continuation) DOCUMENTS CONSIDERED TO BE RELEVANT		
Category °	Citation of document, with indication, where appropriate, of the relevant passages	Relevant to claim No.
A	FR 2 743 570 A (R.E. DEUTSCH) 18 July 1997 see page 3, line 29 - line 37 -----	1,4,5,9, 10,14, 15,19, 20,24, 25, 29-31,35
A	EP 0 708 174 A (INSTITUT FRANCAIS DU PETROLE) 24 April 1996 see page 3, line 4 see page 3, line 4 - line 50 -----	1,4,5, 10,14, 15,19, 20,24, 25,29-31
A	GB 2 071 137 A (TEXACO DEVELOPMENT CORPORATION) 16 September 1981 see page 1, line 35 - line 39 -----	1-3,7,8, 12,13, 17,18, 22,23, 27,28, 31,33,34

INTERNATIONAL SEARCH REPORT

information on patent family members

International Application No

PCT/US 98/18537

Patent document cited in search report	Publication date	Patent family member(s)	Publication date
US 4071438 A	31-01-1978	AU 2568277 A	07-12-1978
		BE 855366 A	03-10-1977
		BR 7703600 A	02-05-1978
		DE 2725132 A	15-12-1977
		FR 2353631 A	30-12-1977
		JP 53016709 A	16-02-1978
		NL 7706149 A	06-12-1977
		SE 7706427 A	04-12-1977
		ZA 7703285 A	26-04-1978
US 4021333 A	03-05-1977	NONE	
FR 2743570 A	18-07-1997	WO 9726314 A	24-07-1997
EP 708174 A	24-04-1996	FR 2725725 A	19-04-1996
		CA 2160652 A	18-04-1996
		CN 1128789 A	14-08-1996
		JP 8199185 A	06-08-1996
		NO 954097 A	18-04-1996
		PL 310964 A	29-04-1996
		US 5759385 A	02-06-1998
		US 5843384 A	01-12-1998
GB 2071137 A	16-09-1981	US 4328092 A	04-05-1982
		AR 229582 A	30-09-1983
		AU 541289 B	03-01-1985
		AU 6694581 A	10-09-1981
		BR 8008360 A	08-09-1981
		CA 1150176 A	19-07-1983
		DE 3107360 A	18-02-1982
		EG 15670 A	30-12-1986
		FR 2477568 A	11-09-1981
		GR 74842 A	12-07-1984
		HR 970291 B	31-10-1997
		JP 1183973 C	27-12-1983
		JP 56129293 A	09-10-1981
		JP 58017792 B	09-04-1983
		NL 8100642 A	01-10-1981
		PT 72450 B	29-01-1982
ZA 8100853 A	30-06-1982		