



US 20180218804A1

(19) **United States**

(12) **Patent Application Publication**

**YAMAZAKI et al.**

(10) **Pub. No.: US 2018/0218804 A1**

(43) **Pub. Date: Aug. 2, 2018**

(54) **DIRECT-CURRENT CABLE, COMPOSITION AND METHOD OF MANUFACTURING DIRECT-CURRENT CABLE**

*C08K 3/22* (2006.01)

*C08L 23/06* (2006.01)

*C08K 3/36* (2006.01)

*C08K 3/04* (2006.01)

(71) Applicant: **SUMITOMO ELECTRIC INDUSTRIES, LTD.**, Osaka (JP)

(52) **U.S. Cl.**

CPC ..... *H01B 3/441* (2013.01); *H01B 7/0275*

(2013.01); *H01B 13/14* (2013.01); *B29C*

*47/0004* (2013.01); *B29C 47/025* (2013.01);

*B29K 2023/0633* (2013.01); *C08K 3/22*

(2013.01); *C08L 23/06* (2013.01); *C08K 3/36*

(2013.01); *C08K 3/04* (2013.01); *B29C 47/78*

(2013.01)

(72) Inventors: **Takanori YAMAZAKI**, Tokyo (JP);  
**Yoshinao MURATA**, Tokyo (JP);  
**Tomohiko KATAYAMA**, Tokyo (JP)

(21) Appl. No.: **15/747,324**

(22) PCT Filed: **Aug. 10, 2015**

(86) PCT No.: **PCT/JP2015/072676**

§ 371 (c)(1),

(2) Date: **Jan. 24, 2018**

**Publication Classification**

(51) **Int. Cl.**

*H01B 3/44* (2006.01)

*H01B 7/02* (2006.01)

*H01B 13/14* (2006.01)

*B29C 47/00* (2006.01)

*B29C 47/02* (2006.01)

*B29C 47/78* (2006.01)

(57)

**ABSTRACT**

A direct-current cable of an embodiment includes a conductive portion; and an insulating layer covering an outer periphery of the conductive portion, the insulating layer containing cross-linked base resin and inorganic filler, the base resin containing polyethylene, a BET specific surface area of the inorganic filler being greater than or equal to 5 m<sup>2</sup>/g, and a mean volume diameter of the inorganic filler being less than or equal to 5 μm, the mass ratio of the inorganic filler with respect to the base resin being greater than or equal to 0.001 and less than or equal to 0.05, and the cross-linked base resin being cross-linked by a cross-linking agent containing organic peroxide.

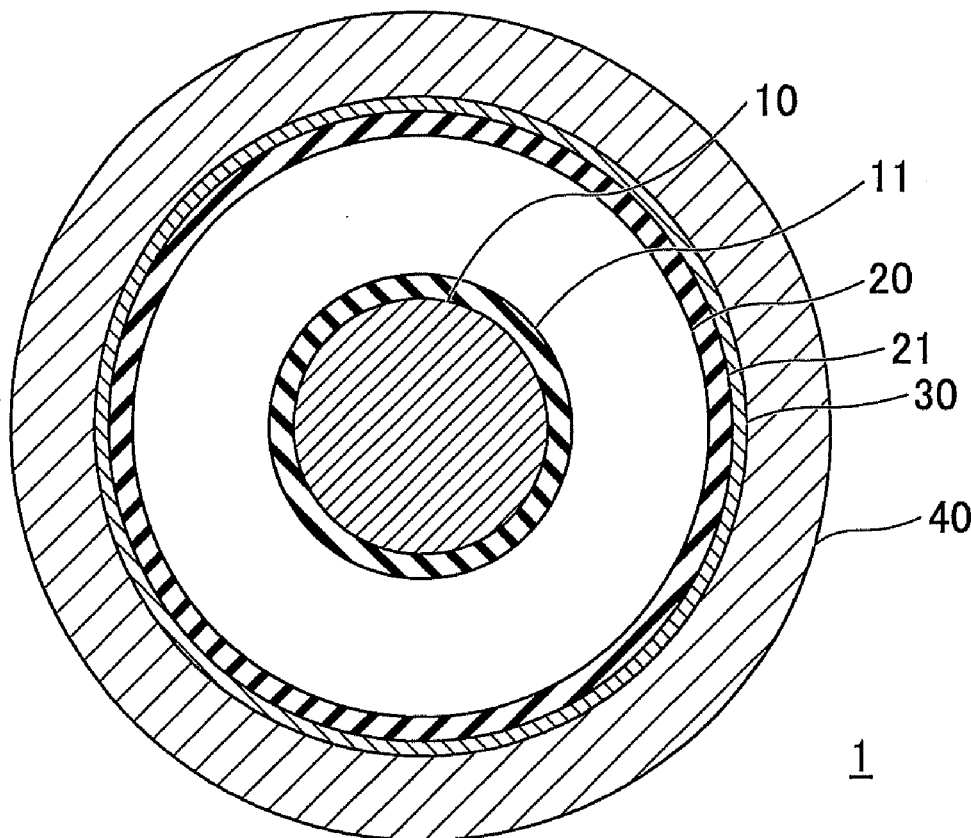
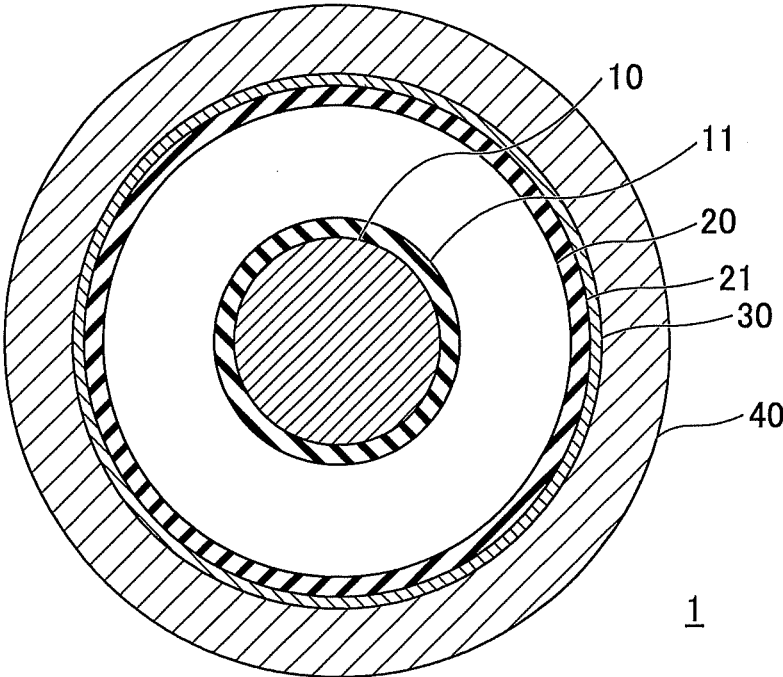

FIG.1



**DIRECT-CURRENT CABLE, COMPOSITION  
AND METHOD OF MANUFACTURING  
DIRECT-CURRENT CABLE**

BACKGROUND OF THE INVENTION

1. Field of the Invention

[0001] An embodiment of the present invention relates to a direct-current cable, a composition and a method of manufacturing a direct-current cable.

[0002] Cross-linking polyethylene cables each containing cross-linking polyethylene in an insulating layer covering an outer periphery of a conductive portion are widely used as alternating-current cables.

[0003] When cross-linking polyethylene, organic peroxide such as dicumyl peroxide is used.

[0004] However, when a cross-linking polyethylene cable is used as a direct-current cable, volume resistivity of an insulating layer may be lowered, accumulation of space charges may be increased and space-charge characteristics may be lowered due to cracked residue of a cross-linking agent.

[0005] Thus, a method of forming an insulating layer containing magnesium oxide or carbon black as an inorganic filler is known (see Patent Documents 1 and 2, for example).

PATENT DOCUMENTS

[Patent Document 1] Japanese Laid-open Patent Publication No. 2014-218617

[Patent Document 2] Japanese Laid-open Patent Publication No. 2015-883

[0006] However, it is desired to improve long-term insulating performance of an insulating layer against applied direct-current voltage.

SUMMARY OF THE INVENTION

[0007] The present invention is made in light of the above problems, and provides a direct-current cable in which long-term insulating performance of an insulating layer against applied direct-current voltage and space-charge characteristics of an insulating layer are good.

[0008] According to an embodiment, there is provided a direct-current cable including a conductive portion; and an insulating layer covering an outer periphery of the conductive portion, the insulating layer containing cross-linked base resin and inorganic filler, the base resin containing polyethylene, a BET specific surface area of the inorganic filler being greater than or equal to 5 m<sup>2</sup>/g, and a mean volume diameter of the inorganic filler being less than or equal to 5 μm, the mass ratio of the inorganic filler with respect to the base resin being greater than or equal to 0.001 and less than or equal to 0.05, and the cross-linked base resin being cross-linked by a cross-linking agent containing organic peroxide.

[0009] According to an embodiment, there is provided a composition including: base resin, inorganic filler and a cross-linking agent, the base resin containing polyethylene, a BET specific surface area of the inorganic filler being greater than or equal to 5 m<sup>2</sup>/g, and a mean volume diameter of the inorganic filler being less than or equal to 5 μm, the mass ratio of the inorganic filler with respect to the base

resin being greater than or equal to 0.001 and less than or equal to 0.05, and the cross-linking agent containing organic peroxide.

[0010] According to an embodiment, a direct-current cable in which long-term insulating performance of an insulating layer against applied direct-current voltage and space-charge characteristics of an insulating layer are good can be provided.

BRIEF DESCRIPTION OF THE DRAWINGS

[0011] FIG. 1 is a cross-sectional view illustrating an example of a direct-current cable.

DETAILED DESCRIPTION OF THE  
PREFERRED EMBODIMENTS

[0012] Next, embodiments are described with reference to drawings.

[0013] FIG. 1 illustrates an example of a direct-current cable. FIG. 1 is a cross-sectional view that is perpendicular to an axial direction of a direct-current cable 1.

[0014] An outer periphery of a conductive portion 10 is covered by an insulating layer 20 in the direct-current cable 1. Further, an inner semi-conducting layer 11 is formed between the conductive portion 10 and the insulating layer 20 in the direct-current cable 1. Further, an outer periphery of the insulating layer 20 is covered by a shielding layer 30, and an outer periphery of the shielding layer 30 is covered by a covering layer 40 in the direct-current cable 1. Further, an outer semi-conducting layer 21 is formed between the insulating layer 20 and the shielding layer 30 in the direct-current cable 1.

[0015] The conductive portion 10 is formed by twisting a plurality of conductive core wires.

[0016] As the material constituting the conductive core wire, although not specifically limited, copper, aluminum, copper alloy, aluminum alloy or the like may be used.

[0017] As the material constituting the inner semi-conducting layer 11, although not specifically limited, ethylene-vinyl acetate copolymer, ethylene-ethyl acrylate copolymer, ethylene-butyl acrylate copolymer or the like may be used.

[0018] The insulating layer 20 contains cross-linked base resin and inorganic filler.

[0019] The base resin contains polyethylene.

[0020] The polyethylene may be either of low density, intermediate density and high density. Further, the polyethylene may be either of straight-chain and branched.

[0021] The cross-linked base resin is cross-linked by a cross-linking agent containing organic peroxide.

[0022] Although the organic peroxide is not specifically limited, dicumyl peroxide, 2,5-dimethyl-2,5-bis(t-butylperoxy)hexane, 1,3-bis(t-butylperoxyisopropyl)benzene or the like may be used.

[0023] The base resin may further contain copolymer of ethylene and polar monomer or polyethylene-graft-maleic anhydride. With this, the long-term insulating performance of the insulating layer 20 against applied direct-current voltage and the space-charge characteristics of the insulating layer 20 can be improved.

[0024] As the polar monomer, although not specifically limited, ethyl acrylate, methacrylate, butyl acrylate, glycidyl methacrylate or the like may be used, and two or more of them may be used in combination.

[0025] The mass ratio of the copolymer of ethylene and polar monomer or the polyethylene-graft-maleic anhydride with respect to the polyethylene is, generally, less than or equal to 1/9, and preferably, less than or equal to 5/95. With this, the long-term insulating performance of the insulating layer 20 against applied direct-current voltage can be improved. The mass ratio of the copolymer of ethylene and polar monomer or the polyethylene-graft-maleic anhydride with respect to the polyethylene is, generally, greater than or equal to 0.01.

[0026] The BET specific surface area of the inorganic filler is greater than or equal to 5 m<sup>2</sup>/g, and preferably, greater than or equal to 20 m<sup>2</sup>/g. If the BET specific surface area of the inorganic filler is less than 5 m<sup>2</sup>/g, the long-term insulating performance of the insulating layer 20 against applied direct-current voltage and the space-charge characteristics of the insulating layer 20 are lowered. Here, the BET specific surface area of the inorganic filler is, generally, less than or equal to 100 m<sup>2</sup>/g.

[0027] The mean volume diameter of the inorganic filler is less than or equal to 5 μm, and preferably, less than or equal to 2 μm. If the mean volume diameter of the inorganic filler exceeds 5 μm, the long-term insulating performance of the insulating layer 20 against applied direct-current and the space-charge characteristics of the insulating layer 20 are lowered. The mean volume diameter of the inorganic filler is, generally, greater than or equal to 0.5 μm.

[0028] The mass ratio of the inorganic filler with respect to the base resin is 0.001 to 0.05, and preferably, 0.005 to 0.03. If the mass ratio of the inorganic filler with respect to the base resin is less than 0.001 or exceeds 0.05, the long-term insulating performance of the insulating layer 20 against applied direct-current and the space-charge characteristics of the insulating layer 20 are lowered.

[0029] As the inorganic filler, although not specifically limited, magnesium oxide powder, aluminum oxide powder, silica powder, magnesium silicate powder, aluminum silicate powder, carbon black or the like may be used, and two or more of them may be used in combination.

[0030] A surface process by a silane coupling agent may be performed on each of the magnesium oxide powder, the aluminum oxide powder, the silica powder, the magnesium silicate powder and the aluminum silicate powder. With this, the long-term insulating performance of the insulating layer 20 against applied direct-current and the space-charge characteristics of the insulating layer 20 can be improved.

[0031] As the silane coupling agent, although not specifically limited, Vinyltrimethoxysilane, Vinyltriethoxysilane, 2-(3,4-Epoxy)cyclohexyl)ethyltrimethoxysilane, 3-Glycidoxypropylmethyldimethoxysilane, 3-Glycidoxypropyltrimethoxysilane, 3-Glycidoxypropylmethyldiethoxysilane, 3-Glycidoxypropyltriethoxysilane, 3-Methacryloxypropylmethyldimethoxysilane, 3-Methacryloxypropyltrimethoxysilane, 3-Methacryloxypropylmethyldiethoxysilane, 3-Methacryloxypropyltriethoxysilane, 3-Acryloxypropyltrimethoxysilane, N-(2-Aminoethyl)-3-aminopropylmethyldimethoxysilane, N-(2-Aminoethyl)-3-aminopropyltriethoxysilane, N-(2-Aminoethyl)-3-aminopropyltriethoxysilane, 3-Aminopropyltrimethoxysilane, 3-Aminopropyltriethoxysilane, 3-Triethoxysilyl-N-(1,3-dimethylbutylidene)propylamine or the like may be used, and two or more of them may be used in combination.

[0032] Here, the inorganic filler whose surface is treated by a silane coupling agent and the inorganic filler whose surface is not treated by a silane coupling agent may be used together in combination.

[0033] A grinding process may be performed on the inorganic filler. For example, a grinding process by jet grinding may be performed on the inorganic filler, whose particle size becomes larger as being adhered with each other when performing the surface treatment using the silane coupling agent.

[0034] The insulating layer 20 may further contain an anti-oxidizing agent. With this, thermal aging resistance of the insulating layer 20 can be improved.

[0035] As the anti-oxidizing agent, although not specifically limited, 2,2-Thiodiethylene-bis[3-(3,5-di-t-butyl-4-hydroxyphenyl)propionate],

[0036] Pentaerythrityl-tetrakis(3-(3,5-di-t-butyl-4-hydroxyphenyl)propionate), Octadecyl 3-(3,5-di-t-butyl-4-hydroxyphenyl)propionate, 2,4-Bis(n-octylthiomethyl)-o-cresol, 2,4-Bis(n-octylthio)-6-(4-hydroxy-3,5-di-t-butylanilino)-1,3,5-triazine, Bis[2-methyl-4-{3-n-alkyl (C12 or C14) thiopropionyloxy}-5-t-butylphenyl]sulfide, 4,4'-Thiobis(3-methyl-6-t-butylphenol) or the like may be used, and two or more of them may be used in combination.

[0037] The insulating layer 20 may further contain lubricant, a coloring agent or the like.

[0038] As the material constituting the outer semi-conducting layer 21, although not specifically limited, ethylene-vinyl acetate copolymer or the like may be used.

[0039] As the material constituting the shielding layer 30, although not specifically limited, copper or the like may be used.

[0040] As the material constituting the covering layer 40, although not specifically limited, polyvinyl chloride or the like may be used.

[0041] The direct-current cable 1 may be applied for power transmission of direct-current power or the like.

[0042] Next, an example of a method of manufacturing the direct-current cable 1 is described.

[0043] The inner semi-conducting layer 11, the insulating layer 20 and the outer semi-conducting layer 21 are formed by extrusion molding a raw material of the inner semi-conducting layer 11, the composition containing the base resin, the inorganic filler and the cross-linking agent as a raw material of the insulating layer 20 and a raw material of the outer semi-conducting layer 21 at the same time at the outer periphery of the conductive portion 10, and heating it to a predetermined temperature to cross-link the base resin. Next, the shielding layer 30 is formed by winding a conductive wire such as a copper tape, or an annealed copper wire around the outer periphery of the outer semi-conducting layer 21. Further, the covering layer 40 is formed at an outer periphery of the shielding layer 30 by extrusion molding a raw material of the covering layer 40.

[0044] As the method of manufacturing the composition, although not specifically limited, a method or the like may be used in which the base resin, the inorganic filler, if necessary, the anti-oxidizing agent, the lubricant, the coloring agent and the like are kneaded to manufacture pellets, and thereafter, the cross-linking agent is heated and impregnated to the pellets.

[0045] Here, the composition may be extrusion molded by removing aggregates by using a screen mesh.

[0046] Further, the raw material of the inner semi-conducting layer 11, the above described composition and the raw material of the outer semi-conducting layer 21 may be extrusion molded at the same time.

#### EXAMPLES

[0047] Next, examples of the invention are described. Here, a term “parts” means “parts by weight”.

##### Example 1

[0048] 100 parts of low density polyethylene (LDPE) with a density of 0.920 g/mm<sup>3</sup>, and MFR (Melt Flow Rate) of 1 g/10 min as the base resin, 0.1 parts of magnesium oxide powder with a BET specific surface area of 30 m<sup>2</sup>/g, and a mean volume diameter of 0.45 μm as the inorganic filler, and 0.2 parts of 4,4'-thiobis(3-methyl-6-t-butylphenol) as the anti-oxidizing agent were heated and kneaded at about 180° C. to manufacture pellets. Next, 2 parts of dicumyl peroxide as the cross-linking agent was heated and impregnated to the obtained pellets at about 60° C. to obtain composition.

##### Example 2

[0049] Composition was obtained similarly as Example 1 except that the amount of the inorganic filler was changed to 1 part.

##### Example 3

[0050] Composition was obtained similarly as Example 1 except that the amount of the inorganic filler was changed to 5 parts.

##### Example 4

[0051] Composition was obtained similarly as Example 2 except that magnesium oxide powder with a BET specific surface area of 145 m<sup>2</sup>/g, and a mean volume diameter of 0.50 μm whose surface was treated by vinyltrimethoxysilane as the silane coupling agent was used, as the inorganic filler.

##### Example 5

[0052] Composition was obtained similarly as Example 4 except that 97 parts of LDPE with a density of 0.920 g/mm<sup>3</sup>, and MFR (Melt Flow Rate) of 1 g/10 min, and 3 parts of polyethylene-graft-maleic anhydride (MA-g-PE) with a density of 0.920 g/mm<sup>3</sup>, and MFR (Melt Flow Rate) of 1 g/10 min were used, as the base resin.

##### Example 6

[0053] Composition was obtained similarly as Example 5 except that 1.3 parts of 2,5-dimethyl-2,5-bis(t-butylperoxy) hexane was used, as the cross-linking agent.

##### Example 7

[0054] Composition was obtained similarly as Example 6 except that magnesium oxide powder with a BET specific surface area of 30 m<sup>2</sup>/g, and a mean volume diameter of 0.05 μm whose surface was treated by vinyltrimethoxysilane as the silane coupling agent was used, as the inorganic filler.

##### Example 8

[0055] Composition was obtained similarly as Example 6 except that magnesium oxide powder with a BET specific

surface area of 8 m<sup>2</sup>/g, and a mean volume diameter of 0.2 μm whose surface was treated by vinyltrimethoxysilane as the silane coupling agent was used, as the inorganic filler.

##### Example 9

[0056] Composition was obtained similarly as Example 6 except that 95 parts of LDPE with a density of 0.920 g/mm<sup>3</sup>, and MFR (Melt Flow Rate) of 1 g/10 min, and 5 parts of ethylene-ethyl acrylate copolymer (poly(E-co-EA)), in which the content of units originated from ethyl acrylate was 7 mass %, with a density of 0.930 g/mm<sup>3</sup> and MFR (Melt Flow Rate) of 4 g/10 min were used, as the base resin, and silica powder with a BET specific surface area of 50 m<sup>2</sup>/g, and a mean volume diameter of 0.03 μm was used, as the inorganic filler.

##### Example 10

[0057] Composition was obtained similarly as Example 6 except that silica powder with a BET specific surface area of 90 m<sup>2</sup>/g, and a mean volume diameter of 0.02 μm was used, as the inorganic filler.

##### Example 11

[0058] Composition was obtained similarly as Example 6 except that 97 parts of LDPE with a density of 0.920 g/mm<sup>3</sup>, and MFR (Melt Flow Rate) of 1 g/10 min, and 3 parts of poly(E-co-EA), in which the content of units originated from ethyl acrylate was 7 mass %, with a density of 0.930 g/mm<sup>3</sup>, and MFR (Melt Flow Rate) of 4 g/10 min were used, as the base resin, alumina powder with a BET specific surface area of 120 m<sup>2</sup>/g, and a mean volume diameter of 0.02 μm was used, as the inorganic filler, and 1,3-bis(t-butylperoxyisopropyl)benzene was used, as the cross-linking agent.

##### Example 12

[0059] Composition was obtained similarly as Example 6 3.0 except that 93 parts of LDPE with a density of 0.920 g/mm<sup>3</sup> and MFR (Melt Flow Rate) of 1 g/10 min, and 7 parts of poly(E-co-EA) whose EA concentration was 7% with a density of 0.930 g/mm<sup>3</sup>, and MFR (Melt Flow Rate) of 4 g/10 min were used, as the base resin, and carbon black with a BET specific surface area of 50 m<sup>2</sup>/g, and a mean volume diameter of 0.05 μm was used, as the inorganic filler.

##### Example 13

[0060] Composition was obtained similarly as Example 6 except that 1 part of magnesium oxide powder with a BET specific surface area of 145 m<sup>2</sup>/g, and a mean volume diameter of 0.50 μm whose surface was treated by vinyltrimethoxysilane as the silane coupling agent, and 2 parts of silica powder with a BET specific surface area of 50 m<sup>2</sup>/g, and a mean volume diameter of 0.03 μm were used, as the inorganic filler.

##### Example 14

[0061] Composition was obtained similarly as Example 6 except that 2 parts of magnesium oxide powder with a BET specific surface area of 145 m<sup>2</sup>/g, and a mean volume diameter of 0.50 μm whose surface was treated by vinyltrimethoxysilane as the silane coupling agent, and 3 parts of

alumina powder with a BET specific surface area of 120 m<sup>2</sup>/g, and a mean volume diameter of 0.02 μm were used, as the inorganic filler.

Comparative Example 1

[0062] Composition was obtained similarly as Example 1 except that the inorganic filler was not used.

Comparative Example 2

[0063] Composition was obtained similarly as Example 1 except that the amount of the inorganic filler was changed to 10 parts.

Comparative Example 3

[0064] Composition was obtained similarly as Example 1 except that 2 parts of magnesium oxide powder with a BET specific surface area of 1.4 m<sup>2</sup>/g, and a mean volume diameter of 3 μm was used, as the inorganic filler.

Comparative Example 4

[0065] Composition was obtained similarly as Example 1 except that 2 parts of magnesium oxide powder with a BET specific surface area of 0.5 m<sup>2</sup>/g, and a mean volume diameter of 17 μm was used, as the inorganic filler.

Comparative Example 5

[0066] Composition was obtained similarly as Example 1 except that 2 parts of alumina powder with a BET specific

surface area of 4.1 m<sup>2</sup>/g, and a mean volume diameter of 1.5 μm was used, as the inorganic filler.

[0067] Characteristics of inorganic fillers contained in the compositions are illustrated in Table 1.

TABLE 1

MATERIAL	BET SPECIFIC SURFACE AREA [m <sup>2</sup> /g]	MEAN VOLUME DIAMETER [μm]	SURFACE TREATMENT
1 MAGNESIUM OXIDE	145	0.5	WITH
2 MAGNESIUM OXIDE	30	0.45	WITHOUT
3 MAGNESIUM OXIDE	30	0.05	WITH
4 MAGNESIUM OXIDE	8	0.2	WITH
5 SILICA	50	0.03	WITHOUT
6 SILICA	90	0.02	WITHOUT
7 ALUMINA	120	0.02	WITHOUT
8 CARBON BLACK	50	0.05	WITHOUT
9 MAGNESIUM OXIDE	1.4	3	WITHOUT
10 MAGNESIUM OXIDE	0.5	17	WITHOUT
11 ALUMINA	4.1	1.5	WITHOUT

[0068] Characteristics of the compositions are illustrated in Table 2.

TABLE 2

	AMOUNT OF BASE RESIN [PARTS]			INORGANIC FILLER			
	LDPE	MA-g-PE	Poly (E-co-EA)	NO.	AMOUNT [PARTS]	NO.	AMOUNT [PARTS]
EXAMPLE 1	100	0	0	2	0.1	—	—
EXAMPLE 2	100	0	0	2	1	—	—
EXAMPLE 3	100	0	0	2	5	—	—
EXAMPLE 4	100	0	0	1	1	—	—
EXAMPLE 5	97	3	0	1	1	—	—
EXAMPLE 6	97	3	0	1	1	—	—
EXAMPLE 7	97	3	0	3	1	—	—
EXAMPLE 8	97	3	0	4	1	—	—
EXAMPLE 9	95	0	5	5	1	—	—
EXAMPLE 10	97	3	0	6	1	—	—
EXAMPLE 11	97	0	3	7	1	—	—
EXAMPLE 12	93	0	7	8	1	—	—
EXAMPLE 13	97	3	0	1	1	3	2
EXAMPLE 14	97	3	0	1	2	5	3
COMPARATIVE EXAMPLE 1	100	0	0	—	—	—	—
COMPARATIVE EXAMPLE 2	100	0	0	2	10	—	—
COMPARATIVE EXAMPLE 3	100	0	0	9	2	—	—
COMPARATIVE EXAMPLE 4	100	0	0	10	2	—	—
COMPARATIVE EXAMPLE 5	100	0	0	11	2	—	—

[0069] Each of the compositions was press molded to obtain a sheet with thickness T of 0.15 mm.

[0070] Next, specific volume resistance, long-term insulating performance against applied direct-current voltage and space-charge characteristics of each of the sheets were evaluated.

(Specific Volume Resistance)

[0071] Specific volume resistance was measured by soaking the sheet in silicone oil of 90° C., and applying a direct electric field of 80 kV/mm to the sheet using a flat plate electrode with a diameter of 25 mm.

(Long-Term Insulating Performance Against Applied Direct-Current Voltage)

[0072] Using the sheet, a V-t curve was obtained by soaking the sheet in silicone oil of 90° C., applying a direct electric field  $V_0$  [kV/mm] of 10 to 300 kV/mm to the sheet using a flat plate electrode with a diameter of 25 mm and measuring a period “t” [h] until dielectric breakdown occurs in the sheet. Next, life exponent “n” was obtained from the formula

$$V_0^n \times t = \text{const.},$$

[0073] and long-term insulating performance against applied direct-current voltage was evaluated. Here, when “n” was greater than or equal to 20, it was determined to be double circle, when “n” was greater than or equal to 15 and less than 20, it was determined to be “0” (circle), and when “n” was less than 15, it was determined to be “x”.

(Space-Charge Characteristics)

[0074] Space-charge characteristics of the sheet were evaluated using a Pulsed Electro Acoustic Non-destructive Test System (manufactured by Five Lab). Specifically, space-charge characteristics of the sheet was evaluated by continuously applying a direct electric field  $V_0$  of 50 kV/mm to the sheet under atmospheric pressure at 30° C. for an hour, measuring maximum electric field  $V_1$  in the sheet, and obtaining Field Enhancement Factor FEF defined by the formula

$$V_1 / (V_0 \times T).$$

[0075] Here, when the FEF was less than 1.15, it was determined to be “o” (circle) and when the FEF was greater than or equal to 1.15, it was determined to be “x”.

[0076] Evaluated results of the specific volume resistance, the long-term insulating performance against applied direct-current current and the space-charge characteristics of each of the sheets are illustrated in Table 3.

TABLE 3

	SPECIFIC VOLUME RESISTANCE [Ω · cm]	LONG-TERM INSULATING PERFORMANCE AGAINST DIRECT-CURRENT	SPACE-CHARGE CHARACTERISTICS
EXAMPLE 1	$1 \times 10^{15}$	○	○
EXAMPLE 2	$3 \times 10^{15}$	○	○
EXAMPLE 3	$2 \times 10^{15}$	○	○
EXAMPLE 4	$6 \times 10^{15}$	⊙	○
EXAMPLE 5	$8 \times 10^{15}$	⊙	○

TABLE 3-continued

	SPECIFIC VOLUME RESISTANCE [Ω · cm]	LONG-TERM INSULATING PERFORMANCE AGAINST DIRECT-CURRENT	SPACE-CHARGE CHARACTERISTICS
EXAMPLE 6	$4 \times 10^{15}$	⊙	○
EXAMPLE 7	$7 \times 10^{15}$	⊙	○
EXAMPLE 8	$6 \times 10^{15}$	⊙	○
EXAMPLE 9	$5 \times 10^{15}$	⊙	○
EXAMPLE 10	$5 \times 10^{15}$	⊙	○
EXAMPLE 11	$6 \times 10^{15}$	⊙	○
EXAMPLE 12	$4 \times 10^{15}$	⊙	○
EXAMPLE 13	$7 \times 10^{15}$	⊙	○
EXAMPLE 14	$5 \times 10^{15}$	⊙	○
COMPARATIVE EXAMPLE 1	$2 \times 10^{13}$	X	X
COMPARATIVE EXAMPLE 2	$1 \times 10^{15}$	X	X
COMPARATIVE EXAMPLE 3	$1 \times 10^{14}$	X	X
COMPARATIVE EXAMPLE 4	$2 \times 10^{14}$	X	X
COMPARATIVE EXAMPLE 5	$9 \times 10^{13}$	X	X

[0077] From Table 3, for each of the sheets manufactured from the compositions of Examples 1 to 13, respectively, it can be understood that the specific volume resistance is high, and the long-term insulating performance against applied direct-current voltage and the space-charge characteristics are good.

[0078] On the other hand, as the sheet manufactured from the composition of Comparative example 1 does not contain inorganic filler, the specific volume resistance, the long-term insulating performance against applied direct-current voltage and the space-charge characteristics are lowered.

[0079] For the sheet manufactured from the composition of Comparative example 2, as the mass ratio of the inorganic filler 2 with respect to the base resin is 0.1, the long-term insulating performance against applied direct-current voltage and the space-charge characteristics are lowered.

[0080] For the sheets manufactured from the compositions of Comparative examples 3 and 5, as the BET specific surface area of each of the inorganic filler are 1.4 m<sup>2</sup>/g and 4.1 m<sup>2</sup>/g, respectively, the specific volume resistance, the long-term insulating performance against applied direct-current voltage and the space-charge characteristics are lowered.

[0081] For the sheet manufactured from the composition of

[0082] Comparative example 4, as the BET specific surface area and the mean volume diameter of the inorganic filler are 0.5 m<sup>2</sup>/g and 17 μm, respectively, the specific volume resistance, the long-term insulating performance against applied direct-current voltage and the space-charge characteristics are lowered.

(Manufacturing of Direct-Current Cable 1)

[0083] First, the conductive portion 10 formed by twisting conductive core wires made of a dilute copper alloy with a diameter of 14 mm was prepared. Next, the inner semi-conducting layer 11 made of ethylene-ethyl acrylate copolymer, the composition as the raw material of the insulating layer 20 and the outer semi-conducting layer 21 made of ethylene-ethyl acrylate copolymer were extrusion molded at

the same time at the outer periphery of the conductive portion **10** to be the thicknesses of 1 mm, 14 mm and 1 mm, respectively. Then, the product was heated at about 250° C. to cross link the base resin and to form the inner semi-conducting layer **11**, the insulating layer **20** and the outer semi-conducting layer **21**. Next, the shielding layer **30** was formed by winding a conductive wire such as an annealed copper wire or the like with the diameter of 1 mm around the outer periphery of the outer semi-conducting layer **21**. Then, the covering layer **40** with the thickness of 3 mm was formed by extrusion molding polyvinyl chloride at the outer periphery of the shielding layer **30** to obtain the direct-current cable **1**.

#### NUMERALS

- [0084] **1** direct-current cable
- [0085] **10** conductive portion
- [0086] **11** inner semi-conducting layer
- [0087] **20** insulating layer
- [0088] **21** outer semi-conducting layer
- [0089] **30** shielding layer
- [0090] **40** covering layer

What is claimed is:

1. A direct-current cable comprising:
  - a conductive portion; and
  - an insulating layer covering an outer periphery of the conductive portion,
  - the insulating layer containing cross-linked base resin and inorganic filler,
  - the base resin containing polyethylene,
  - a BET specific surface area of the inorganic filler being greater than or equal to 5 m<sup>2</sup>/g, and a mean volume diameter of the inorganic filler being less than or equal to 5 μm,
  - the mass ratio of the inorganic filler with respect to the base resin being greater than or equal to 0.001 and less than or equal to 0.05, and
  - the cross-linked base resin being cross-linked by a cross-linking agent containing organic peroxide.
2. The direct-current cable according to claim 1, wherein the inorganic filler is one or more selected from a group consisting of magnesium oxide powder, aluminum oxide powder, silica powder, magnesium silicate powder, aluminum silicate powder and carbon black.
3. The direct-current cable according to claim 2, wherein a surface of each of the magnesium oxide powder, the

aluminum oxide powder, the silica powder, the magnesium silicate powder and the aluminum silicate powder is treated by a silane coupling agent.

4. The direct-current cable according to claim 1, wherein the base resin further contains copolymer of ethylene and polar monomer or polyethylene-graft-maleic anhydride, and wherein the mass ratio of the copolymer of ethylene and polar monomer or the polyethylene-graft-maleic anhydride with respect to the polyethylene is less than or equal to 1/9.
5. A composition comprising: base resin, inorganic filler and a cross-linking agent,
  - the base resin containing polyethylene,
  - a BET specific surface area of the inorganic filler being greater than or equal to 5 m<sup>2</sup>/g, and a mean volume diameter of the inorganic filler being less than or equal to 5 μm,
  - the mass ratio of the inorganic filler with respect to the base resin being greater than or equal to 0.001 and less than or equal to 0.05, and
  - the cross-linking agent containing organic peroxide.
6. The composition according to claim 5, wherein the inorganic filler is one or more selected from a group consisting of magnesium oxide powder, aluminum oxide powder, silica powder, magnesium silicate powder, aluminum silicate powder and carbon black.
7. The composition according to claim 6, wherein a surface of each of the magnesium oxide powder, the aluminum oxide powder, the silica powder, the magnesium silicate powder and the aluminum silicate powder is treated by a silane coupling agent.
8. The composition according to claim 5, wherein the base resin further contains copolymer of ethylene and polar monomer or polyethylene-graft-maleic anhydride, and wherein the mass ratio of the copolymer of ethylene and polar monomer or the polyethylene-graft-maleic anhydride with respect to the polyethylene is less than or equal to 1/9.
9. A method of manufacturing a direct-current cable in which an outer periphery of a conductive portion is covered by an insulating layer, comprising:
  - manufacturing an extrusion molded material by extrusion molding the composition as claimed in claim 5 to cover an outer periphery of the conductive portion; and
  - forming the insulating layer by heating the extrusion molded material at a predetermined temperature to cross link the base resin.

\* \* \* \* \*