

(No Model.)

J. K. VAN PELT.

VEHICLE WHEEL.

No. 384,482.

Patented June 12, 1888.

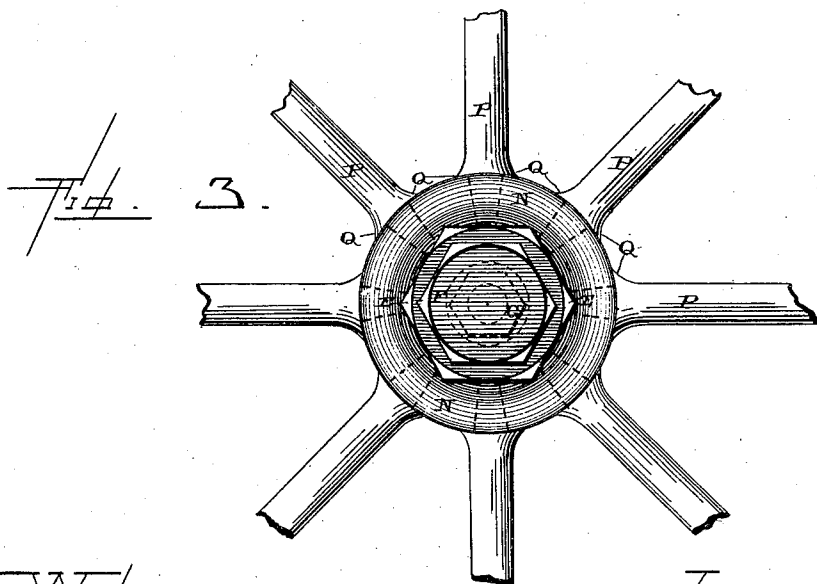
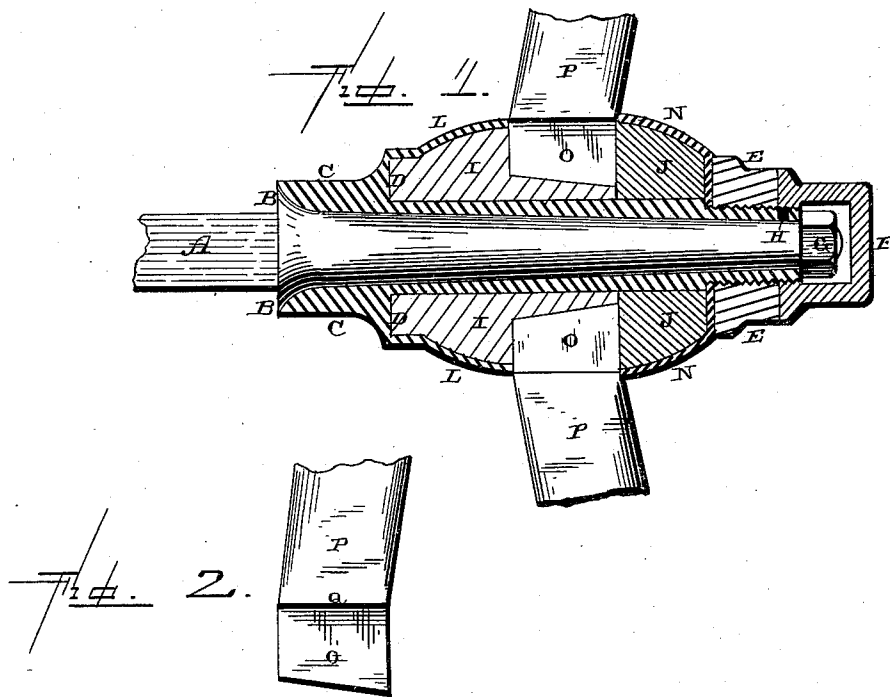

Witnesses.

*R. T. Gardner,*  
*Edm. P. Ellis.*

*Inventor.*  
*J. K. Van Pelt.*  
*per F. A. Lehmann,*  
*att'y*

# UNITED STATES PATENT OFFICE.

JOHN K. VAN PELT, OF NASHVILLE, TENNESSEE.

## VEHICLE-WHEEL.

SPECIFICATION forming part of Letters Patent No. 384,482, dated June 12, 1888.

Application filed February 21, 1888. Serial No. 264,804. (No model.)

*To all whom it may concern:*

Be it known that I, JOHN K. VAN PELT, of Nashville, in the county of Davidson and State of Tennessee, have invented certain new and useful Improvements in Vehicle-Wheels; and I do hereby declare the following to be a full, clear, and exact description of the invention, such as will enable others skilled in the art to which it pertains to make and use it, reference being had to the accompanying drawings, which form part of this specification.

My invention relates to an improvement in vehicle-wheels; and it consists in the hub, which is formed of both wood and iron, and in which the two wooden parts are inclosed within an iron shell, and the sockets to receive the ends of the hubs are made inclined at their bottoms so as to correspond to the inclines upon the inner ends of the hubs, the spokes also being provided with shoulders, which rest or bear against the outer side of the hub, as will be more fully described hereinafter.

The object of my invention is to produce a hub which is formed of both metal and wood, so as to do away with the rigidity of an iron hub, and to so construct the parts that should one of the spokes become broken or injured and have to be removed it is only necessary to remove a portion of the hub, and then force the new spoke into place in such a manner as to tighten the felly against the tire, and at the same time tighten the spoke in place at a great saving of time, labor, and cost over the repairs upon a wheel of ordinary construction.

Figure 1 is a vertical longitudinal section taken through the hub. Fig. 2 is a side elevation of the inner end of a spoke alone. Fig. 3 is an end view of the hub.

A represents the axle, which has its collar B beveled upon its outer side so as to form a feather-edge, and C the box, which also has its inner end beveled to a feather-edge to correspond to the shape of the flange on the axle. Upon this box is formed the shoulder D, and the outer end of the box is screw-threaded, so as to receive the nut E and the cap F. The nut G upon the end of the axle abuts against the end of the box, and this nut G is inclosed by the cap F, for the purpose of making a dust and dirt tight joint. Through the outer end of the

box is made an oil-opening, H, through which oil can be poured into the box for the purpose of lubrication, and which opening is closed by the cap F. The hub proper is composed of the two wooden parts I J and the two metallic shells L N, which shells inclose the two wooden parts and hold them in position upon the box C, as shown. The wooden part I of the hub is provided with the sockets to receive the tenons O on the inner ends of the spokes P, and the bottom of the sockets are slightly inclined toward the outer end of the axle, so as to correspond to the inclination of the outer ends of the tenons on the spokes. The two edges of each tenon is placed at a suitable inclination to the body of the spoke, so as to give the wheel a suitable amount of dish. The ends of the tenons O and the bottoms of the sockets in the part I are placed at a suitable inclination, as shown, so that in case any one of the spokes should become injured or broken and have to be removed it will only be necessary to remove the wooden portion J of the hub and the metal portion N, when the end of the injured spoke can be forced outward out of the socket and then withdrawn from the felly without having to displace any of the other portions of the wheel. In inserting a new spoke it is only necessary to insert the tenon on the outer end of the spoke into the socket in the felly, and then insert the tenon O in the outer edge of the socket in the part I, and then force the tenon O sidewise into position, thus both tightening the felly against the tire and tightening the spoke in position at the same time. Each spoke has two shoulders, Q, formed near its inner end, and these shoulders rest solidly against the wooden portion I of the hub, so as to receive all of the elasticity of the wood. The wooden portion J is made of greater diameter than the part I, and bears against the end of the wooden part and the sides of the ends of the spokes so as to give both flanges the same size when the hub is all closed up. The metal cap N is passed over this part J and secured rigidly in position by the nut E and the cap F. In case the box should become worn out or injured, so that it would have to be replaced, it can be removed from the hub without displacing any of the parts and a new one inserted.

The wooden portions J L may be saturated with oil or paint at any time, and thus prevent it from dry-rot.

5 Having thus described my invention, I claim—

10 The combination of the axle A, provided with the collar B, which is beveled upon its inner side, the box C, having its inner end made to conform to the collar and provided with the shoulder D at its inner end and a screw-thread at its outer end, the wooden part

I, having inclined sockets to receive the tenons O on the inner ends of the spokes P, the wooden part J, the shell N, the nuts E G, and the cap F, substantially as shown and described. 15

In testimony whereof I affix my signature in presence of two witnesses.

JOHN K. VAN PELT.

Witnesses:

A. W. WILLS,  
F. A. DRAPER.