



US00D337091S

**United States Patent** [19]  
**Fleet**

[11] **Patent Number:** **Des. 337,091**  
[45] **Date of Patent:** **\*\* Jul. 6, 1993**

[54] **COMBINED SHIP MOUNTED OIL SPILL  
CONTAINMENT BOOM AND MOUNTING  
PLATE**

**FOREIGN PATENT DOCUMENTS**

730652 5/1955 United Kingdom ..... 114/74

[76] **Inventor:** **Douglas N. Fleet, 14 Kingfisher Dr.,  
Smithtown, N.Y. 11787-3312**

*Primary Examiner*—Kay H. Chin  
*Attorney, Agent, or Firm*—Terry M. Gernstein

[\*\*] **Term:** **14 Years**

[57] **CLAIM**

The ornamental design for a combined ship mounted oil spill containment boom and mounting plate, as shown and described.

[21] **Appl. No.:** **570,706**

**DESCRIPTION**

[22] **Filed:** **Aug. 22, 1990**

[52] **U.S. Cl. .... D12/317; D8/349**

[58] **Field of Search .... D12/317; 114/74 T;  
405/66, 67, 68, 69, 70; D8/317**

FIG. 1 is a front and top perspective view of the combined ship mounted oil spill containment boom and mounting plate embodying the design of the present invention;

FIG. 2 is a front perspective view thereof in the collapsed configuration;

FIG. 3 is a front elevational view thereof;

FIG. 4 is a rear elevational view thereof;

FIG. 5 is a side elevational view thereof;

FIG. 6 is a side elevational view thereof;

FIG. 7 is a top plan view thereof; and,

FIG. 8 is a bottom view thereof.

[56] **References Cited**

**U.S. PATENT DOCUMENTS**

2,682,151	6/1954	Simpson et al. ....	405/68
3,563,036	2/1971	Smith et al. ....	405/69
3,802,201	4/1974	Hoult et al. ....	405/68
5,071,545	12/1991	Ashtary ....	405/66

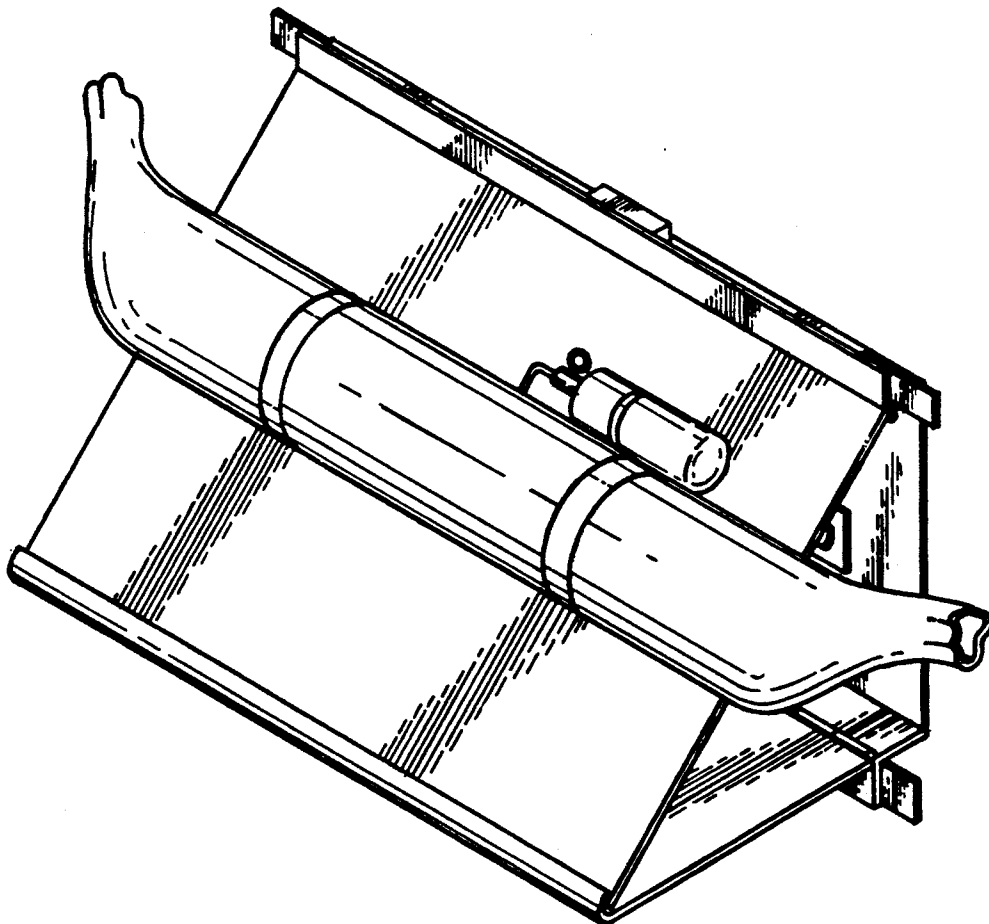

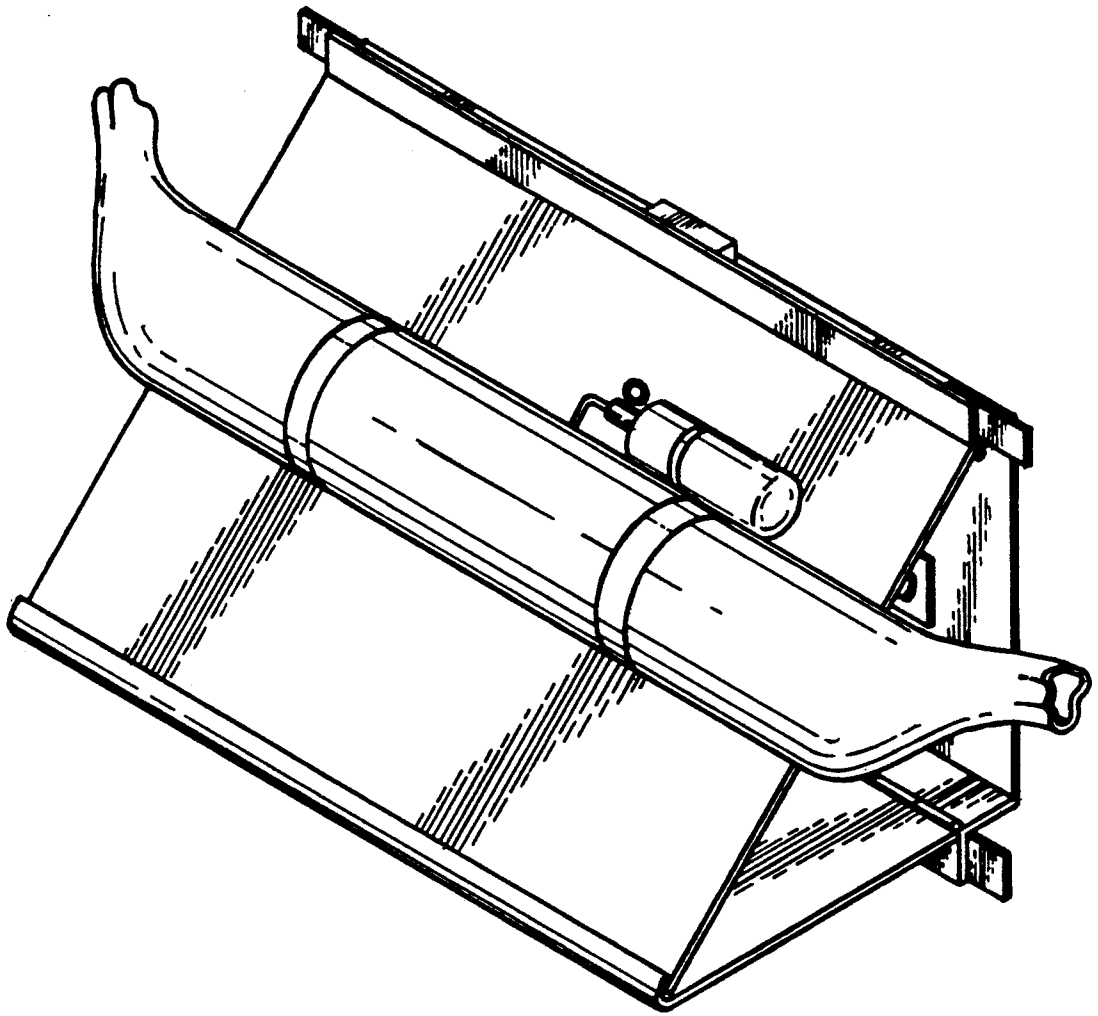

FIG.1

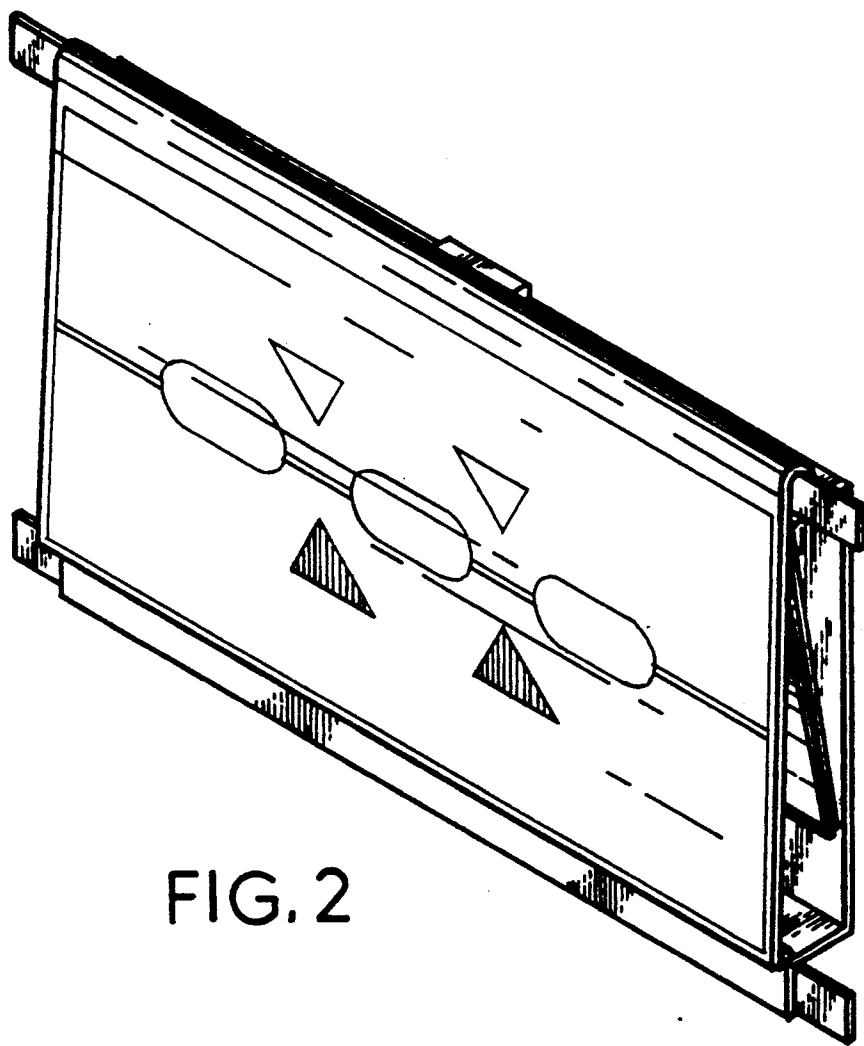

FIG. 2

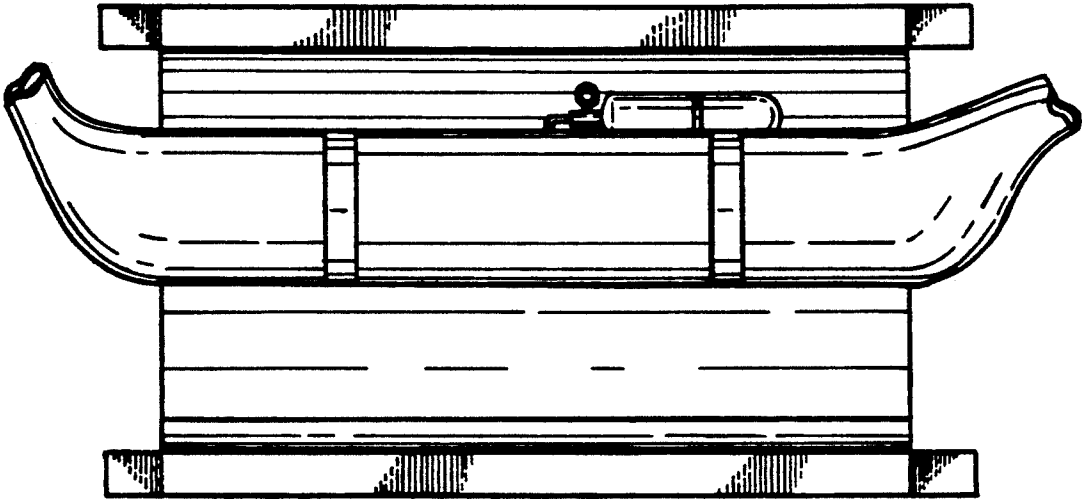

FIG. 3

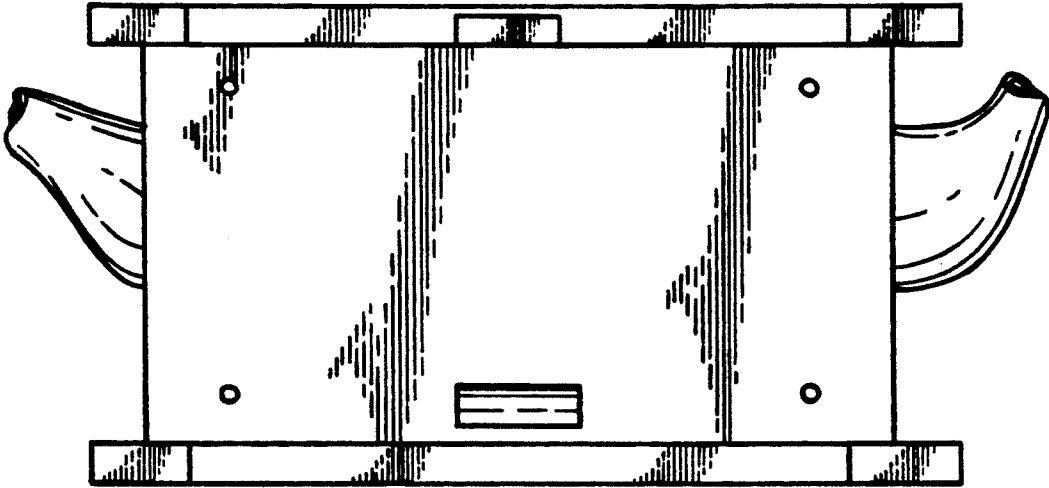

FIG. 4

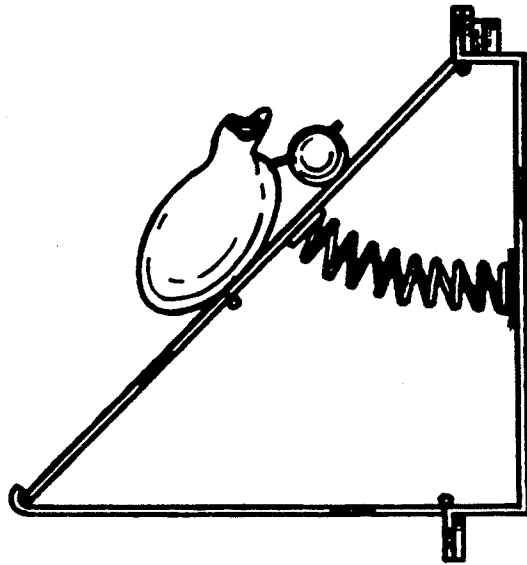

FIG. 5

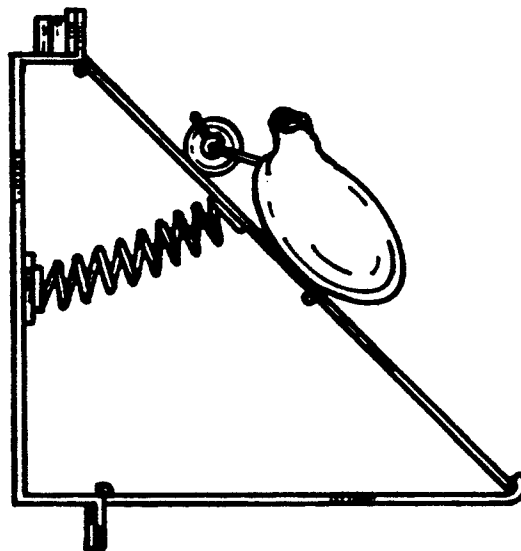

FIG. 6

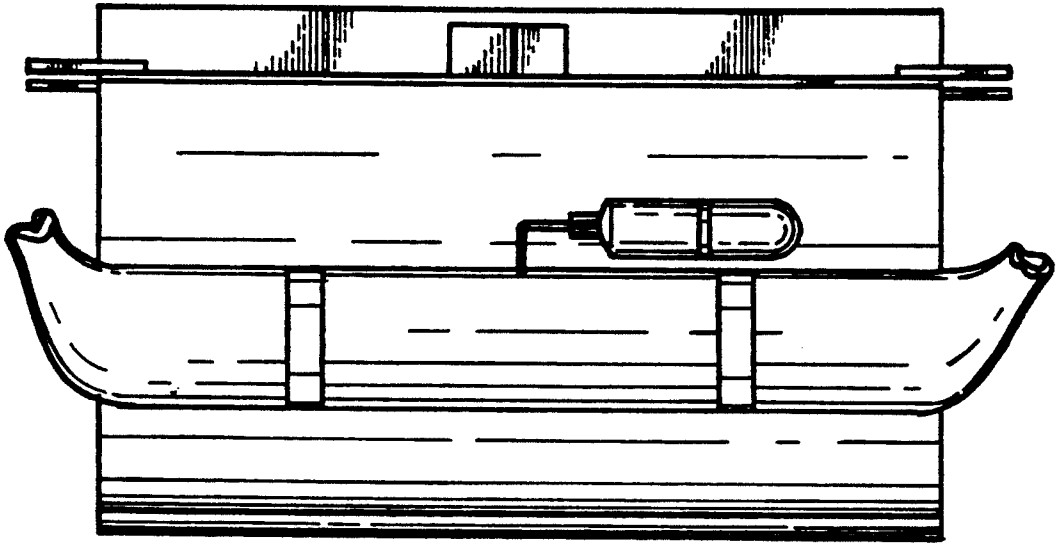

FIG. 7

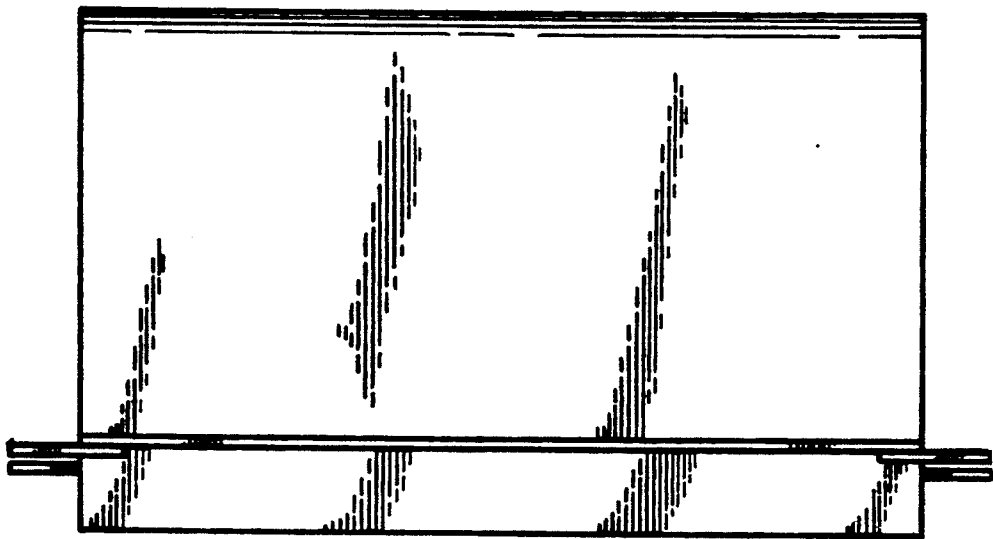

FIG. 8