

A. E. JONES.
 AUTOMOBILE TORPEDO.
 APPLICATION FILED DEC. 22, 1910.

996,412.

Patented June 27, 1911.

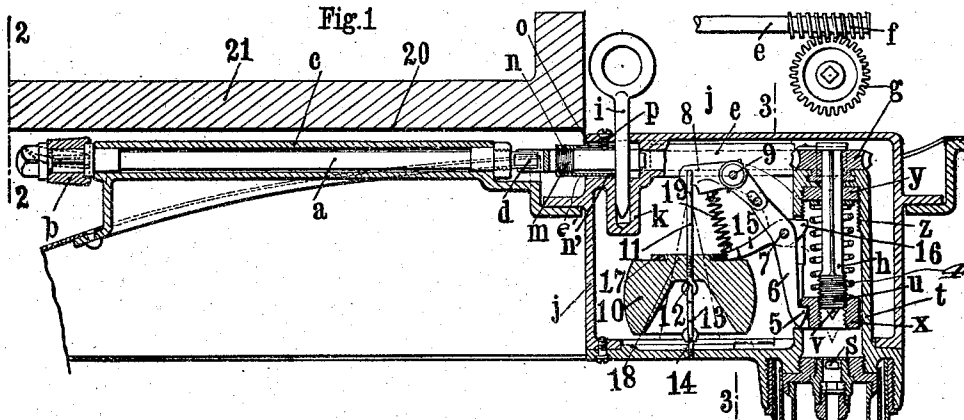

Fig. 2.

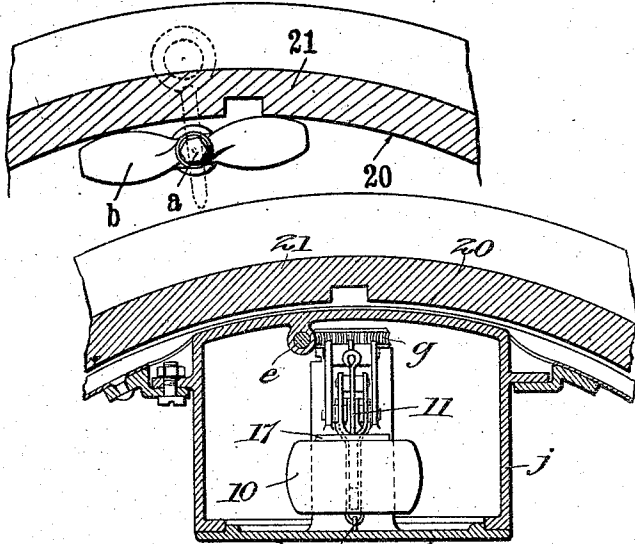
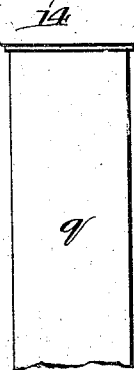

Fig. 3



WITNESSES
J. P. Davis
P. L. Rollhaus

INVENTOR
 Albert Edward Jones
 BY *Mumfles*
 ATTORNEYS

UNITED STATES PATENT OFFICE.

ALBERT EDWARD JONES, OF FIUME, AUSTRIA-HUNGARY, ASSIGNOR TO WHITEHEAD AND COMPANY, OF FIUME, AUSTRIA-HUNGARY, A CORPORATION.

AUTOMOBILE TORPEDO.

996,412.

Specification of Letters Patent. Patented June 27, 1911.

Application filed December 22, 1910. Serial No. 598,698.

To all whom it may concern:

Be it known that I, ALBERT EDWARD JONES, a subject of the King of Great Britain, and resident of Via Volosca No. 2, Fiume, Austria-Hungary, have invented certain new and useful Improvements in and Relating to Automobile Torpedoes, of which the following is a full and complete description.

10 This invention has for its object a percussion mechanism or pistol for automobile torpedoes. It aims more particularly at permitting of the release of the striker no matter at what angle the torpedo strikes its mark while at the same time avoiding any incorrect operation and the cocking of the striker before and during firing and so long as the torpedo is in proximity to the vessel from which it is launched.

20 The invention is illustrated in the accompanying drawing, in which:

Figure 1 shows the device in longitudinal section, Fig. 2 is a cross section on the line 2—2 in Fig. 1. Fig. 3 is a cross section on the line 3—3 in Fig. 1.

30 The shaft a which carries the propeller b intended for cocking the striker in the known manner, instead of being located in the longitudinal axis of the torpedo is located outside this axis and guided in a sleeve c which is preferably tangential to the torpedo at the origin of the ogive. The shaft a is coupled by means of an appropriate joint d with the shaft e ending in an endless screw f meshing with a worm wheel g which operates the striker h .

40 The safety pin i instead of being, as heretofore arranged in front of the propeller b , passes through the shaft e at its part e' in passing through the box j of the striker and lodges in an inner socket k in this box.

45 The part e' of the shaft e is threaded at m for the reception of a sleeve n formed with a longitudinal groove o in which a screw p engages.

50 The percussion mechanism proper comprises the usual cartridge q , the detonator r , the cap s and the striker h movable in a tube t arranged inside the box j of the apparatus, located outside the longitudinal axis of the torpedo preferably at the origin of the ogive. The striker h ends in a screw threaded head u and a point v screwed into a piston x which is able to slide but not to rotate in the tube t . This striker h , which is square

in cross section, carries above a nut y which is screwed onto a threaded portion z of the tube t and it engages in the hub of the worm wheel g meshing with the endless screw f in which the shaft $a—e$ of the propeller b ends; this shaft can be locked by means of the safety pin i . Between the nut y and the piston x a spring 4 is interposed. The piston x bears upon the tooth 5 of a lever 6 which is provided with a fixed pivot 7 and is itself connected with a two armed lever 8 with fixed pivot 9 . A pendulum 10 is suspended from the end of the lever 8 by the intermediary of the rod 11 which is itself connected by a universal joint or the like 12 to a rod 13 pivoted at 14 to the bottom of the box j . Upon the pivot 7 a lever 15 is also pivoted; this lever ends on the one hand in a tooth 16 projecting into the tube t and on the other hand in a ring 17 which embraces a shoulder 18 on the pendulum 10 . A compression spring 19 connects the levers 8 and 15 .

55 The operation is as follows: When the torpedo is introduced into its tube the pin i is in place and locks the shaft a in the position represented in Fig. 2 in which the inner wall 20 of the launching tube 21 constitutes an obstacle to the rotation of the propeller. When the propeller has been introduced into the tube, the safety pin i is withdrawn and the arrangement of the torpedo in position is completed. During the travel of the torpedo, the propeller b is rotated together with the shafts a , e' and e with which it is connected, thereby rotating the pinion g which cocks the striker h .

60 In the mechanism the parts occupy normally the position shown in Fig. 1, that is to say the spring 4 is neither extended nor compressed, the point v of the striker h is located inside the piston x , the piston x is supported by the tooth 5 of the lever 6 and finally the ring 17 of the lever 15 embraces the shoulder 18 of the pendulum 10 and locks it. In these conditions, if for any reason the tooth 5 should release the piston x the percussion point v is nevertheless quite unable to strike the cap s . When the torpedo is traveling (the safety pin i having necessarily been removed) by means of its shaft $a—e$ and the endless screw f the propeller b rotates the worm wheel g which imparts a movement of rotation to the striker h . Owing to this movement the head u is

screwed into the piston x so as to cause the projection of the point v and simultaneously the nut y is screwed downward in the thread z so as to compress the spring 4 and cock the striker. This compression ceases immediately the striker h of square section has descended sufficiently to become released from the worm wheel g . The nut y in descending bears at a certain moment upon the tooth 16 of the lever 15 which lifts the ring 17 of this lever and releases it from the shoulder 18 of the pendulum 10 which is then free to rock. Now if the torpedo should encounter an obstacle at any angle, the pendulum 10, which by reason of its suspension can rock in every direction exerts traction upon its supports and connections 11 and 13 and consequently depresses the end of the lever 8 which rocks the lever 6 and releases the tooth 5 of the piston x which becomes free and is at once depressed carrying with it the striker h the point v of which strikes the cap s .

The firing mechanism can be rendered more or less sensitive by modifying the strength of the spring 19.

The advantages are as follows:—The torpedo cannot be introduced into the launching tube until the safety pin i has been removed, in such a manner that the propeller b cannot remain locked during the travel of the torpedo and will efficiently fulfil its purpose which consists in cocking the striker. The propeller b is unable to rotate while the torpedo is in the launching tube 21 because (see Fig. 2) its blades are stopped by the inner wall of the said tube. Consequently the striker cannot become prematurely cocked. The device also prevents the striker from becoming cocked by unauthorized persons by withdrawing the safety pin i from its housing, by rotating the propeller b by hand so as to cock the striker and then replacing the pin i so that apparently the torpedo presents all the conditions of safety while in reality it could be exploded by the first shock. In point of fact if the pin i is withdrawn from its housing and the propeller b be rotated, the sleeve n arranged upon the shaft e' advances and its end n' obturates the entrance of the pin which cannot then be placed. It is therefore necessary, in order to replace the pin i , to uncock the striker. As the propeller and the striker are no longer located at the point of the torpedo the explosive charge can be continued as far as this point, in such a manner that it is in more direct contact with the mark. Owing to this same arrangement it is also possible to increase the usual length of the torpedo and consequently to increase either the volume of the charge or the capacity of the air reservoir. As the motor member 10 which is assimilable to the trigger of a pistol is constituted by a pendulum

capable of oscillating in every direction the release of the striker h takes place upon the least shock against the torpedo no matter at what angle this torpedo strikes its target. The mechanism therefore becomes absolutely independent of contact between the propeller b and the target which is the case with the direct contact strikers arranged in the axis and at the point of the torpedo. In addition the device presents all the necessary qualities of safety during operation and of firing the torpedo.

Having now particularly described and ascertained the nature of my invention and in what manner the same is to be performed, I declare that what I claim is:

1. In a percussion mechanism for automobile torpedoes, a cylinder, a piston movable in the cylinder, a striker screwing into the piston, a lever provided with a tooth engaging the piston to hold the striker in cocked position, a second lever connected with the first lever, a pendulum suspended from the second lever, a third lever engaging the pendulum and projecting into the cylinder to be operated by the striker, and a spring connecting the second and third levers whereby the striker will be released when the torpedo strikes an obstacle no matter at what angle the torpedo strikes said obstacle.

2. In a percussion mechanism for automobile torpedoes, a piston, a striker having a point normally within the piston, and a lever provided with a tooth engaging the piston to support the same, whereby the point of the striker will be prevented from striking the cap if it should be accidentally released.

3. In a percussion mechanism for automobile torpedoes, a cylinder, a piston movable in the cylinder, a striker screwing into the piston, a lever provided with a tooth engaging the piston to hold the striker cocked, a second lever connected with the first lever, a pendulum suspended from the second lever, a third lever engaging the pendulum to normally hold it stationary, said lever projecting into the cylinder, a spring connecting the second and third levers, and a nut carried by the striker and adapted to engage the portion of the third lever projecting into the cylinder.

4. In a percussion mechanism for automobile torpedoes, a cylinder, a piston movable in the cylinder, a striker screwing into the piston, a lever having a tooth engaging the piston to support the striker in cocked position, a second lever connected with the first lever, a pendulum suspended from the second lever, a third lever operatively connected with the second lever and engaging the pendulum to normally hold it stationary, said third lever being provided with a tooth projecting into the cylinder, means

for cocking the striker, and means for operating the third lever from the striker.

5 In a percussion mechanism for automobile torpedoes, a launching tube, a 5
striker, a propeller, and a propeller shaft for cocking the striker, said propeller shaft extending into the launching tube and arranged outside of the longitudinal axis of the torpedo, whereby the inner wall of the 10
launching tube will form an obstacle to the rotation of the propeller during the charging of the torpedo.

6. In a percussion mechanism for automobile torpedoes, a striker, a propeller, a 15
propeller shaft for cocking the striker, said propeller shaft extending into the launching tube and arranged outside of the longitudinal axis of the torpedo, and a safety pin engaging the rear part of the propeller 20
shaft, whereby the removal of the safety pin will be necessary before completing the loading.

7. In a percussion mechanism for automobile torpedoes the combination of the 25
striker with a propeller shaft for cocking the striker, said propeller shaft being arranged outside the longitudinal axis of the torpedo, a safety pin arranged on the rear part of the propeller shaft, a movable but 30
non-rotative sleeve on the propeller shaft close to the hole for the safety pin, a screw thread in the sleeve engaging with a screw thread on the shaft and a pin *p* in the casing of the mechanism engaging a groove *o* 35
in the sleeve.

8. In a percussion mechanism for automobile torpedoes, the combination of a 40
striker, a lever mechanism for holding the striker in its cocked position, a pendulum for releasing the striker, means for holding and releasing the pendulum, means for 45
cocking the striker, and safety means for preventing undue cocking of the striker, substantially as set forth.

9. In a percussion mechanism for torpedoes; a striker, means for holding the 45
striker in cocked position, a pendulum for operating the holding means to release the striker, and means controlled by the striker for holding the pendulum normally stationary. 50

10. In a percussion mechanism for torpedoes, a striker, means for cocking the 55
striker, means for holding the striker in cocked position, a pendulum for operating the holding means to release the striker, means for holding the pendulum normally stationary, and means, whereby the pendulum will be released when the striker is 60
cocked.

11. In a percussion mechanism for torpedoes, a cylinder, a piston free to slide but 65
not to turn in the cylinder, a striker carried by the piston, means for cocking the striker, means engaging the piston to hold the striker cocked, a pendulum for operating the holding means to release the striker, means for normally holding the pendulum stationary, and a member carried by the 70
striker and operating the means which holds the pendulum to release the same when the striker has been moved to cocked position.

12. In a percussion mechanism for torpedoes, a cylinder, a piston free to slide but 75
not to turn in the cylinder, a striker screwing into the piston, a nut on the striker and in threaded engagement with the cylinder, a spring surrounding the striker between the nut and piston, means for turning the 80
striker, whereby it will be cocked, and means for holding the striker cocked.

In testimony whereof I have hereunto placed my hand at Fiume, Austria-Hungary this sixth day of December 1910.

ALBERT EDWARD JONES.

In the presence of two witnesses:

ATTILIO J. CLEMENTI,
JOSEPH AUGURELIN.