

(12) PATENT
(19) AUSTRALIAN PATENT OFFICE

(11) Application No. AU 200131890 B2
(10) Patent No. 764863

(54) Title
Transmission of information symbols on multiplex channels

(51) ⁶ International Patent Classification(s)
H04J 013/02

(21) Application No: 200131890 (22) Application Date: 2001.01.12

(87) WIPO No: W001/52458

(30) Priority Data

(31) Number	(32) Date	(33) Country
00/00494	2000.01.14	FR

(43) Publication Date : 2001.07.24
(43) Publication Journal Date : 2001.10.04
(44) Accepted Journal Date : 2003.09.04

(71) Applicant(s)
Nortel Networks Limited

(72) Inventor(s)
Evelyne Le Strat; Catherine Leretaille; Stephane Gosne

(74) Agent/Attorney
PHILLIPS ORMONDE and FITZPATRICK, 367 Collins Street, MELBOURNE
VIC 3000

(56) Related Art
GB 2308044

AU 200131890

(12) DEMANDE INTERNATIONALE PUBLIÉE EN VERTU DU TRAITÉ DE COOPÉRATION EN MATIÈRE DE BREVETS (PCT)

(19) Organisation Mondiale de la Propriété Intellectuelle
Bureau international



(43) Date de la publication internationale
19 juillet 2001 (19.07.2001)

PCT

(10) Numéro de publication internationale
WO 01/52458 A3

- (25) Classification internationale des brevets⁷ : H04L 1/00
 (21) Numéro de la demande internationale : PCT/FR01/00106
 (22) Date de dépôt international : 12 janvier 2001 (12.01.2001)
 (25) Langue de dépôt : français
 (26) Langue de publication : français
 (30) Données relatives à la priorité : 00/00494 14 janvier 2000 (14.01.2000) FR
 (71) Déposant (pour tous les États désignés sauf US) : NORTEL NETWORKS LIMITED [CA/CA]; 2351 bld. Alfred Nobel, St. Laurent, Quebec H4S 2A9 (CA).
 (72) Inventeurs : et
 (75) Inventeurs/Déposants (pour US seulement) : LE STRAT,
 Evelyne [FR/FR]; 22, rue Marmontel, F-75015 Paris (FR).
 LERETAILE, Catherine [FR/FR]; 147, rue de Vaugirard, F-75015 Paris (FR).
 GOSNE, Stéphane [FR/FR]; 6, rue Edouard Branly, F-92130 Issy-les-Moulineaux (FR).
 (74) Mandataires : LOISEL, Bertrand etc.; Cabinet Plasseraud, 84, rue d'Amsterdam, F-75440 Paris Cedex 09 (FR).
 (81) États désignés (national) : AE, AG, AL, AM, AT, AU, AZ, BA, BB, BG, BR, BY, BZ, CA, CH, CN, CR, CU, CZ, DE, DK, DM, DZ, EE, ES, FI, GB, GD, GE, GH, GM, HR, HU, ID, IL, IN, IS, JP, KE, KG, KP, KR, KZ, LC, LK, LR, LS, LT, LU, LV, MA, MD, MG, MK, MN, MW, MX, MZ, NO, NZ, PL, PT, RO, RU, SD, SE, SG, SI, SK, SL, TJ, TM, TR, TT, TZ, UA, UG, US, UZ, VN, YU, ZA, ZW.
 (84) États désignés (régional) : brevet ARIPO (GH, GM, KE, LS, MW, MZ, SD, SL, SZ, TZ, UG, ZW), brevet eurasien (AM, AZ, BY, KG, KZ, MD, RU, TJ, TM), brevet européen (AT, BE, CH, CY, DE, DK, ES, FI, FR, GB, GR, IE, IT, LU, MC, NL, PT, SE, TR), brevet OAPI (BF, BJ, CF, CG, CI, CM, GA, GN, GW, ML, MR, NE, SN, TD, TG).

[Suite sur la page suivante]

(54) Title: TRANSMISSION OF INFORMATION SYMBOLS ON MULTIPLEX CHANNELS

(54) Titre : EMISSION DE SYMBOLES D'INFORMATION SUR DES CANAUX MULTIPLEXES

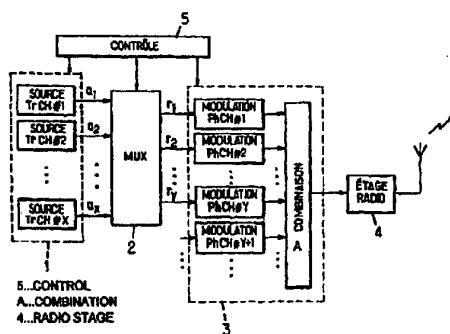

(57) Abstract: A diagram for transport channel multiplexing on one or several communication channels is adapted to operate in normal mode and compressed mode, thereby requiring a lower symbol rate in which inactive periods are provided in the communication channels. In order to adapt rates on each of the transport channels, symbols are stamped at two different times: marked symbols are initially introduced, which undergo various processing steps, particularly interleaving with other information bits before they are excluded from the transmitted sequence. Said processing steps can be similarly carried out in normal mode and in compressed mode, thereby limiting entity complexity in communication.

(57) Abrégé : Un schéma de multiplexage de canaux de transport sur un ou plusieurs canaux de communication est adapté pour fonctionner dans un mode normal et un mode comprimé, requérant un débit de symboles plus faible dans lequel des périodes inactives sont prévues dans les canaux de communication. Pour adapter le débit sur chacun des canaux de transport, on effectue un poinçonnage de symboles en deux temps: on introduit d'abord des symboles marqués, qui subissent divers traitements notamment d'entrelacement avec les autres bits d'information, avant d'être supprimés de la séquence émise. Ces traitements peuvent ainsi être effectués de façon semblable en mode normal et en mode comprimé, ce qui limite la complexité des entités en communication.

WO 01/52458 A3

WO 01/52458 A3



Publiée :

— avec rapport de recherche internationale

En ce qui concerne les codes à deux lettres et autres abréviations, se référer aux "Notes explicatives relatives aux codes et abréviations" figurant au début de chaque numéro ordinaire de la Gazette du PCT.

(98) Date de publication du rapport de recherche internationale:

4 avril 2002

PROCESSING METHODS AND DEVICES FOR SENDING INFORMATION
SYMBOLS OVER MULTIPLEXED CHANNELS, AND CORRESPONDING
PROCESSING METHODS AND DEVICES FOR RECEPTION

5 The present invention relates to digital transmissions, and more precisely to the shaping of one or more streams of information symbols to be transmitted over one or more communication channels.

10 In the present description, the invention will be described more particularly in its application, nonlimiting, to third generation radio communication networks of the UMTS type ("Universal Mobile Telecommunication System"). A general description of this system is presented in the article: "L'UMTS: la
15 génération des mobiles multimédia" [UMTS: the generation of the multimedia mobile] by P. Blanc et al., L'Echo des Recherches, no. 170, 4th quarter 1997/1st quarter 1998, pages 53-68. In this system, the invention finds application within the framework of
20 downlinks, that is to say from the base stations to the terminal equipment, in frequency duplex mode (or FDD, "Frequency Domain Duplex").

 UMTS is a radio communication system using code-division multiple access (CDMA), that is to say
25 the symbols transmitted are multiplied by spreading codes consisting of samples known as "chips" whose rate (3.84 Mchip/s in the case of UMTS) is greater than that of the symbols transmitted. The spreading codes distinguish between various physical channels PhCH
30 which are superimposed on the same transmission resource constituted by carrier frequency. The auto- and cross-correlation properties of the spreading codes enable the receiver to separate the PhCHs and to extract the symbols intended for it. For UMTS in FDD
35 mode on the downlink, a scrambling code is allocated to each base station, and various physical channels used by this base station are distinguished by mutually orthogonal "channelization" codes. For each PhCH, the global spreading code is the product of the

"channelization" code and the scrambling code of the base station. The spreading factor (equal to the ratio of the chip rate to the symbol rate) is a power of 2 lying between 4 and 512. This factor is chosen as a function of the bit rate of the symbols to be transmitted on the PhCH.

The various physical channels obey a frame structure illustrated in Figure 1. The 10 ms frames follow one another on the carrier frequency used by the base station. Each frame is subdivided into 15 time slots of 666 μ s. Each slot can carry the superimposed contributions of one or more physical channels, comprising common channels and dedicated channels DPCH ("Dedicated Physical CHannel"). The lower chart of Figure 1 illustrates the contribution of a downlink DPCH at a time slot in FDD mode, which comprises:

- a certain number of pilot symbols PL placed at the end of the slot. Known a priori to the terminal, these symbols PL enable it to acquire the synchronization and to estimate parameters which are useful in demodulating the signal;
- a transport format combination indicator TFCI placed at the start of the slot;
- a transmit power control TPC to be used by the terminal on the uplink; and
- two data fields, denoted DATA1 and DATA2, placed either side of the TPC field.

The DPCH can thus be seen as amalgamating a physical channel dedicated to control, or DPCCH ("Dedicated Physical Control CHannel"), corresponding to the fields TFCI, TPC and PL, and a physical channel dedicated to the data, or DPDCH ("Dedicated Physical Data CHannel"), corresponding to the fields DATA1 and DATA2.

For one and the same communication, it is possible to establish several DPCHs corresponding to different "channelization" codes, whose spreading factors may be equal or different. This situation is encountered in particular when a DPDCH is insufficient

to provide the transmission bit rate required by the application. In what follows, Y will denote the number, equal to or greater than 1, of downlink physical channels used for one and the same communication from a base station.

Moreover, this same communication can use one or more transport channels TrCH. Multiplexed TrCHs are typically used for multimedia transmissions, in which signals of different natures to be transmitted simultaneously require different transport characteristics, in particular as regards protection against transmission errors. On the other hand, certain coders may output, in order to represent a given signal (audio for example), several streams of symbols having different perceptual importances and therefore requiring different degrees of protection. Multiple TrCHs are then used to transport these various symbol streams. In what follows, X will denote the number, equal to or greater than 1, of transport channels used for a given communication on the aforesaid Y physical channels.

For each transport channel i ($1 \leq i \leq X$), there is defined a transmission time interval TTI composed of F_i consecutive frames, with $F_i = 1, 2, 4$ or 8 . Typically, the shorter the delay with which the signal conveyed by the transport channel must be received, the shorter is the TTI used. For example, a TTI of 10 ms ($F_i = 1$) will be used for a telephony application, while a TTI of 80 ms ($F_i = 8$) may be used for a data transmission application.

The multiplexing of the X streams of information symbols emanating from the TrCHs on the Y PhCHs is described in detail in the technical specification 3G TS 25.212, "Multiplexing and channel coding (FDD)", version 3.0.0 published in October 1999 by the 3GPP (3rd Generation Partnership Project), which can be loaded from ftp://ftp.3gpp.org/Specs/October_99/25_series/.

Figure 2 diagrammatically illustrates the sending part of a UMTS base station operating in FDD mode. Block 1 denotes the set of sources respectively outputting streams of information symbols a_i ($1 \leq i \leq X$) in relation to the X TrCHs used in a communication.

Block 2 multiplexes the streams a_i to form what is referred to as a coded composite transport channel, or CCTrCH, which is subsequently subdivided into one or more physical channels PhCH# j ($1 \leq j \leq Y$) on which synchronized streams of symbols respectively denoted r_j are transmitted.

Block 3 designates the circuits which modulate the streams r_j and combine them to form a signal processed by the radio stage 4 before being sent over the air interface. Block 3 caters for the spreading, by the "channelization" codes assigned to the PhCHs, of each of the streams r_j , as well as of any additional streams which may be output in respect of other communications supported at the same moment by the base station, the various streams of symbols thus spread being subsequently summed and then multiplied by the scrambling code of the base station. The sequencing and parameterization of blocks 1, 2, 3 is catered for by a control unit 5 in accordance with the parameters defined for the base station and for the relevant communication.

Figure 3 diagrammatically illustrates the receiving part of a UMTS terminal communicating in FDD mode with a base station according to Figure 2. Block 7 demodulates the baseband signal restored by the radio stage 6 from the signal picked up by the antenna of the terminal, using the scrambling code of the base station and the Y "channelization" codes assigned to the terminal. For each of the Y physical channels j ($1 \leq j \leq Y$), block 7 outputs data r'_j representing estimates of the symbols of the stream r_j formed at base station level.

In the case where the symbols are bits, the estimates r'_j are "softbits", that is to say numerical

values whose sign characterizes the estimated bit and whose absolute value represents the likelihood of this estimate.

The Y data streams r'_j are delivered to a demultiplexing block 8 which performs the operations inverse to those of the multiplexer 2 of the base station. This block 8 outputs for each transport channel i ($1 \leq i \leq X$) a stream a'_i of estimates (softbits or hardbits) of the symbols of the stream a_i . These estimates a'_i are delivered to the processing circuit of the TrCH i belonging to the block 9. The sequencing and parameterization of blocks 7, 8, 9 is catered for by a control unit 10 of the terminal.

As is usual in the field of digital radiocommunications, the blocks 1-3,5 of the base station and 7-10 of the terminal can be embodied by programming one or more digital signal processors and/or by using specific logic circuits.

Figures 4 and 5 respectively detail the various functional modules of the multiplexing block 2 and demultiplexing block 8 (see the aforesaid specification 3G TS 25.212). In these figures, the references bearing the index i ($1 \leq i \leq X$) designate the elements referring to TrCH i (blocks 20_i and 40_i), the references bearing the index j designating the elements referring to PhCH j ($1 \leq j \leq Y$), and the references with no index referring to the operations performed for each frame at CCTrCH level.

The stream a_i to be transmitted on each TRCH i is composed of binary symbols output in the form of successive transport blocks TrBk. The module 21_i completes each TrBk by adding thereto a cyclic redundancy code CRC, serving to detect any transmission errors. The TrBk b_i are then concatenated and/or segmented by the module 22_i so as to form blocks o_i of appropriate size for the input of the channel coder 23_i .

For each TTI of transport channel i , the channel coder 23_i outputs a sequence c_i of E_i coded bits

denoted $c_{i,m}$ ($1 \leq m \leq E_i$). Two types of error correcting code may be applied by the module 23_i:

- a convolutional code of rate 1/2 or 1/3 and of constraint length $K = 9$;
- 5 - a turbo code of rate 1/3 for the applications which require the lowest error rates. In this case, the bits $c_{i,3p+q}$ of the output sequence from the coder are systematic bits (copies of the input blocks o_i) if $q = 1$, and parity bits if $q = 2$ or 0 .

10 The bit rate matching modules 24_i delete (puncture) or repeat bits of the sequences c_i so as to match the bit rate of the TrCHs to the global bit rate allowable on the PhCH or PhCHs given their spreading factors. For each TTI on TrCH i , there is defined, from the information provided by the higher protocol layers, a parameter ΔN_i^{TTI} , negative in the case of puncturing and positive in the case of repetition. The sequence g_i produced by the module 24_i for the TTI is composed of G_i
15 $= E_i + \Delta N_i^{TTI}$ bits denoted $g_{i,n}$ ($1 \leq n \leq G_i$). In the case where the module 23_i has used a turbo code, the puncturing applied by the module 24_i if $\Delta N_i^{TTI} < 0$ is limited to the parity bits, given the greater importance of the systematic bits to the decoder.

25 In a given frame, the periods devoted to the various TrCHs of the communication may have fixed positions (before the intra-frame interleaving mentioned below) or variable positions. In the case of fixed positions, it may be necessary to append to the
30 sequence g_i , by means of the module 25_i, one or more marked symbols which will not be transmitted (the value of the corresponding bit will for example be set to zero instead of ± 1 in the output stream r_j comprising such a symbol so that the transmission power of the
35 symbol is zero). The DTX ("Discontinuous Transmission") bits thus marked are denoted " δ ". In the exemplary implementation considered here in a nonlimiting manner, each symbol $h_{i,n}$ of the sequence h_i output by the module

25_i ($0 \leq n \leq F_i \cdot H_i$, with $G_i \leq F_i \cdot H_i$) is represented by two bits:

- $h_{i,n} = (0, g_{i,n})$ if $n \leq G_i$;
- $h_{i,n} = (1, 0)$ if $G_i < n \leq F_i \cdot H_i$ (marked bits "8").

5

The interleaving module 26_i performs a permutation of the sequence h_i , with a view to distributing the symbols pertaining to the TTI over the F_i frames which it covers. This interleaving consists in writing the symbols of the sequence h_i successively into the rows of a matrix comprising F_i columns, in permuting the columns of the matrix, and in then reading the symbols of the matrix column by column to form the sequence denoted q_i . The module 27_i then chops the sequence h_i into F_i segments of consecutive symbols corresponding to the F_i columns of the interleaving matrix after permutation, and respectively assigns these segments to the F_i frames of the TTI to form a sequence denoted f_i for each frame and each TrCH i ($1 \leq i \leq X$).

10
15
20

In accordance with the specification 3G TS 25.212, the permutation of columns performed by the interleaver 26_i is such that the symbol $h_{i,n}$ is found in the frame of rank $n_i = BR(n-1, F_i)$ of the TTI, the frames of the TTI being numbered from $n_i = 0$ to $n_i = F_i - 1$, and $BR(x, 2^y)$ being defined as the integer whose representation to the base 2 corresponds to the reading in the reverse direction of the representation to the base 2 on y digits of the remainder from the Euclidean division of x by 2^y (for example $BR(51, 8) = BR(3, 8) = BR([011]_2, 2^3) = [110]_2 = 6$).

25
30

The sequences f_i produced for the various TrCHs of the communication ($1 \leq i \leq X$) are multiplexed, that is to say placed one after the other, by a module 28 forming a sequence s of S symbols for the CCTrCH. In the case where the periods devoted to the various TrCHs of the communication have variable positions, it may be necessary to append to the sequence s , by means of the module 29, one or more marked symbols "8". In the

35

exemplary implementation considered here, each symbol w_k of the sequence w output by the module 29 ($1 \leq k \leq \sum_{j=1}^Y U_j$,

with $S \leq \sum_{j=1}^Y U_j$ and U_j equal to the number of bits per

frame on the DPDCH of physical channel j , which number
5 depends on the spreading factor allocated to the channel) is represented by two bits:

- $w_k = (0, s_k)$ if $k \leq S$;
- $w_k = (1, 0)$ if $S < k \leq \sum_{j=1}^Y U_j$.

The module 30 subsequently chops the sequence w
10 into Y segments of U_1, U_2, \dots, U_Y consecutive symbols, and respectively assigns these segments to the Y PhCHs to form a sequence denoted u_j for each PhCH j ($1 \leq j \leq Y$). The interleaving module 31_j performs a permutation of the sequence u_j , with a view to distributing the
15 symbols, within the current frame, over the Y PhCHs employed by the communication. This interleaving consists in writing the symbols of the sequence u_j successively to the rows of a matrix comprising thirty columns, in permuting the columns of the matrix, and in
20 then reading the symbols of the matrix column by column to form the sequence, denoted v_j , of U_j symbols.

The module 32_j for mapping the physical channel finally distributes the successive symbols of the sequence v_j into the fields DATA1 and DATA2 of the time
25 slots of the current frame. The module 32_j can translate the information bits with values 0 or 1 into signed bits (± 1), and assign the value 0 to the marked bits "0". It furthermore supplements the stream r_j addressed to the block 3 by inserting the appropriate
30 signalling bits into the fields PL, TFCI and TPC of the DPCCH.

The demultiplexing block 8 comprises modules which perform, in the reverse direction, the operations which are dual to those of the modules 20_i - 32_j of the
35 multiplexing block 2. In Figure 5, the primed

references correspond to the estimates of the symbols bearing the same unprimed references in Figure 4. For the symbols composed of two bits formatted as indicated hereinabove by reason of the marking of the bits "8", these estimates (softbits) refer to the least significant bit.

For each 10 ms frame and each PhCH, the module 52_j extracts the sequence v'_j of U_j softbits pertaining to the DPDCH from the fields DATA1 and DATA2 of the demodulated signal. The deinterleaving module 51_j applies the inverse permutation to that of the module 31_j to this sequence v'_j so as to restore the sequence of softbits u'_j. The Y sequences u'_j are placed end to end by the multiplexing module 50 so as to form the sequence of softbits w' which relates to the CCTrCH. In the case where the TrCH have variable positions, the module 49 deletes the last $\sum_{j=1}^Y U_j - S$ softbits of the sequence w', which correspond to "8" bits. The softbit sequence s' produced by the module 49 is chopped by the segmentation module 49 into X subsequences f'_i respectively assigned to the TrCHs.

For each TrCH i whose TTI comprises several frames (F_i > 1), the module 47_i concatenates the subsequences produced in relation to the various frames so as to form the sequence q'_i subjected to the inter-frame deinterleaving module 46_i. The latter carries out the permutation inverse to that of the module 26_i so as to restore the sequence of softbits h'_i. In the case where the TrCHs have fixed positions, the module 45_i deletes the F_i.H_i - G_i last softbits of the sequence h'_i, which correspond to "8" bits. The sequence of softbits s' produced by the module 49 is then processed by the bit rate matching module 44_i which performs the following operations:

- insertion of a null softbit (minimum likelihood) in place of each bit which has been punctured on transmission;

- reevaluation of each softbit corresponding to a bit which has been repeated on transmission, so as to sharpen the likelihood thereof.

The output sequence c'_i of the module 44_i is
5 decoded by the module 43_i so as to correct any transmission errors. The symbols of the decoded blocks o'_i output by the module 43_i can be softbits, or hardbits if the likelihood measures are no longer required in the subsequent processing. On the basis of
10 these blocks o'_i , the module 42_i reconstructs the estimated TrBk b'_i , and the module 41_i verifies the integrity of the CRC so as to validate these TrBk in the output stream a'_i relating to TrCH i .

In the UMTS system, in particular in FDD mode,
15 there is provision for the communicating terminals to be furnished with time windows so as to listen to one or more carrier frequencies different from that supporting the communication. This listening procedure allows in particular the terminals equipped with a
20 single radio frequency receiver to perform measurements of radio parameters (module 11 of Figure 3) with a view to possible automatic transfer (handover):

- from a UMTS FDD cell to another UMTS FDD cell using a different carrier;
- 25 - from a UMTS FDD cell to a UMTS TDD cell ("Time Domain Duplex"); or else
- from a UMTS FDD cell to a cell of a second-generation network such as a GSM network.

During the listening window, which may extend
30 over one or more time slots of $666 \mu s$, the base station interrupts its transmission to the terminal. This interruption is specific to the air interface, and has no impact on the output bit rate of the sources of the block 1 which relate to the various TrCHs. In the
35 course of each 10 ms frame having an inactive period (during which no symbol is transmitted), it is therefore necessary, outside of this inactive period, to increase the transmission bit rate on the Y PhCHs.

These frames are said to use a compressed mode. In order for the quality in terms of binary error rate (BER) or of frame error rate (FER) not to be affected by the interruption of transmission, the base station transmission power is increased in the compressed-mode frames outside of the inactive period.

The interruptions of transmission can take place periodically or on request. In the course of a given frame, the number of time slots covered by the inactive period is a maximum of 7. The illustration of Figure 1 shows two interruptions of transmission GAP1, GAP2. The interruption GAP1 falls within a single compressed-mode frame T1, while the interruption GAP2 straddles two compressed-mode frames T2, T2'. Interruptions extending over two consecutive frames, such as GAP2, are useful in particular for handovers to the GSM networks requiring a measurement window of 6 ms.

As indicated in the aforesaid specification 3G TS 25.212, an interruption going from slot N_{first} to slot N_{last} begins at the TFCI or DATA2 field of the slot N_{first} , and terminates at the field DATA2 of slot N_{last} . In both cases, the modules 32_j of the multiplexing block 2 generate the inactive period of the compressed-mode frame by placing the information bits in the remaining DATA1 and DATA2 fields.

In compressed mode, two methods A and B can be used to match the bit rate of the PhCHs to that of the TrCHs.

Method A consists in an additional puncturing (relative to that which may be applied by the bit rate matching module 24_i), serving to create the interruption of transmission in each frame concerned.

Method B consists in dividing by 2 the Y spreading factors employed in the compressed-mode frames. A limitation of this method B is that it requires the availability of spreading codes of half factor, thereby penalizing the code resources in the cell.

Method A poses a problem when the communication uses at least one TrCH whose transmission time interval covers several frames ($F_i > 1$): if one of these frames is in compressed mode, then the additional puncturing
5 must be carried out specifically in this frame, this being tricky given the interleaving applied by the modules 26_i and the shifts generated in the sequence of symbols by the bit rate matching module 24_i. An additional constraint in the case where a turbo code is
10 used for the channel coding on a TrCH is that it is not desirable to puncture systematic bits.

Accordingly, the compressed mode according to method A requires a priori fairly significant modifications to the multiplexing and demultiplexing
15 suite according to Figures 4 and 5, and hence an increase in the complexity of the base stations and terminals, which must naturally be compatible both with the compressed mode and with the noncompressed mode.

An aim of the present invention is to limit the
20 impact of these problems in the systems using a processing suite of the kind described above.

The invention thus proposes a method of processing X streams of information symbols to be transmitted on Y communication channels, X and Y being
25 positive integers, in which the Y communication channels simultaneously occupy a transmission resource organized as successive frames, in which the successive frames include compressed-mode frames having at least one inactive period during which no symbol is
30 transmitted, in which the information symbols of each stream i ($1 \leq i \leq X$) are transmitted in the course of successive transmission time intervals each comprising F_i consecutive frames, F_i being a positive integer, and in which, for each transmission time interval relating
35 to a stream i ($1 \leq i \leq X$), integers E_i , ΔN_i^{TTI} and ΔN_i^{cm} are defined such that $E_i > 0$, $\Delta N_i^{\text{cm}} < 0$ if the said transmission time interval comprises at least one compressed-mode frame and $\Delta N_i^{\text{cm}} = 0$ if the said transmission time interval does not comprise any

compressed-mode frame. The method comprises the following steps for each transmission time interval relating to a stream i ($1 \leq i \leq X$):

- 5 - forming a first sequence of E_i symbols coded on the basis of information symbols of the said stream pertaining to the said transmission time interval;
- 10 - forming a second sequence of symbols including $E_i + \Delta N_i^{\text{TTI}} + \Delta N_i^{\text{cm}}$ symbols extracted from the first sequence and $-\Delta N_i^{\text{cm}}$ marked symbols;
- 15 - forming a third sequence of symbols by a permutation of the symbols of the second sequence;
- distributing the symbols of the third sequence into F_i segments of consecutive symbols, the F_i segments being respectively assigned to the frames of the said transmission time interval; and
- 20 - for each frame of the said transmission time interval, forming a fourth sequence of symbols extracted from the segment assigned to the said frame,

the said permutation and the placing of the marked symbols in the second sequence when the said transmission time interval comprises at least one compressed-mode frame being such that each marked symbol belongs, in the third sequence, to a segment assigned to a compressed-mode frame, and the following steps for each frame:

- 30 - forming a fifth sequence of symbols including the symbols of the fourth sequence output for the said frame in relation to each stream;
- distributing the symbols of the fifth sequence into Y segments of symbols, the Y segments being respectively assigned to the Y communication channels;
- 35 - for each communication channel, forming a sixth sequence of symbols extracted from the segment assigned to the said communication channel;

- for each communication channel, forming a seventh sequence of symbols by a permutation of the symbols of the sixth sequence; and
- transmitting on each communication channel, in
5 time slots of the said frame, symbols extracted from the seventh sequence,

each of the said marked symbols being deleted before transmission on each communication channel when the said frame is in compressed mode, so as to husband the
10 said inactive period in the course of the frame.

The $-\Delta N_i^{cm}$ marked symbols correspond to those to which the additional puncturing is applied within the framework of method A mentioned above. The use of a marking makes it possible not to actually puncture them
15 at the bit rate matching level, so as to avoid having to modify the interleaving and segmentation modules 26_i , 27_i , and possibly the other modules of the processing suite. This results in a simplification of the communicating entities since these same modules may
20 be used in the same way in compressed mode and in noncompressed mode.

In a preferred mode of execution of the process, the said marked symbols are kept until the seventh sequences when the frame is in compressed mode,
25 without being extracted from the seventh sequences for transmission. In the application described earlier, this makes it possible not to modify any of the modules 26_i to 31_j of the suite of Figure 4, nor any of the modules 46_i to 51_j of the suite of Figure 5.

The process is compatible with the use of the DTX bits, as described earlier. For this purpose, it is sufficient to insert additional marked symbols, kept until the seventh sequences so as to be transmitted with zero transmission power, into the second or the
30 fifth sequence. It is noted that the insertion of the $-\Delta N_i^{cm}$ marked symbols for the additional puncturing can be performed either before, or after the insertion of the DTX bits in the case where the TrCHs have fixed positions, that is to say before or after module 25_i .
35

Another aspect of the present invention relates to a device adapted to the implementation of the above method, comprising

- 5 - means for forming a first sequence of E_i coded symbols on the basis of information symbols of each stream i ($1 \leq i \leq X$) pertaining to a transmission time interval;
- 10 - means for forming, for each transmission time interval relating to a stream i ($1 \leq i \leq X$), a second sequence of symbols including $E_i + \Delta N_i^{TTI} + \Delta N_i^{cm}$ symbols extracted from the first sequence and $-\Delta N_i^{cm}$ marked symbols;
- 15 - means for forming a third sequence of symbols by a first permutation of the symbols of each second sequence;
- 20 - means for distributing the symbols of each third sequence, which is formed for a transmission time interval relating to a stream i ($1 \leq i \leq X$), into F_i segments of consecutive symbols respectively assigned to the frames of the said transmission time interval, and for forming F_i fourth sequences of symbols respectively extracted from the segments assigned to the said frames;
- 25 - means for forming, for each frame, a fifth sequence of symbols including the symbols of the fourth sequence output for the said frame in relation to each stream i ($1 \leq i \leq X$);
- 30 - means for distributing the symbols of each fifth sequence into Y segments of symbols respectively assigned to the Y communication channels;
- 35 - means for forming a sixth sequence of symbols extracted from the segment assigned to each communication channel; and
- means for forming a seventh sequence of symbols by a second permutation of the symbols of each sixth sequence, and for transmitting, in time slots of each frame on each communication

channel, symbols extracted from the seventh sequence c and the said communication channel, in which the first permutation and the placing of the marked symbols in the second sequence, which is formed for a transmission time interval relating to a stream $i(1 \leq i \leq X)$ when the said transmission time interval comprises at least one compressed-mode frame, are such that each marked symbol belongs, in the third sequence which is formed for the said transmission time interval, to a segment assigned to a compressed-mode frame, each of the said marked symbols being deleted before transmission on each communication channel so as to husband the said inactive period in the course of the frame.

This device can in particular form part of a UMTS base station such as described hereinabove. The invention also has an impact at the level of the terminals, whose demultiplexing suite must be adapted.

Another aspect of the invention thus relates to a method of processing Y digital streams obtained on the basis of a signal received and comprising estimates of information symbols respectively transmitted along Y communication channels simultaneously occupying a transmission resource organized as successive frames, and pertaining to X transport channels, X and Y being positive integers, in which the successive frames include compressed-mode frames having at least one inactive period during which no symbol is transmitted, and in which the estimates of information symbols pertaining to each transport channel $i(1 \leq i \leq X)$ are received in the course of successive transmission time intervals each comprising F_i consecutive frames, F_i being a positive integer. This method comprises the following steps for each frame:

- forming, in relation to each communication channel $j(1 \leq j \leq Y)$, a first sequence composed of estimates extracted from the time slots of the said frame and, when the said frame is in compressed mode, of marked

estimates placed at positions corresponding to the inactive period of the said frame;

- for each communication channel, forming a second sequence of estimates by a permutation of the estimates of the first sequence;
- forming a third sequence of estimates including estimates of the second sequence which is output for each communication channel; and
- distributing the estimates of the third sequence into X segments of consecutive estimates, the X segments being respectively assigned to the X transport channels,

and the following steps for each transmission time interval relating to a transport channel $i(1 \leq i \leq X)$;

- forming a fourth sequence by concatenating the respective segments assigned to the said transport channel for the frames of the said transmission time interval;
- permuting the estimates of the fourth sequence and forming a fifth sequence of estimates extracted from the fourth permuted sequence;
- ignoring each marked estimate of the fifth sequence, and forming a sixth sequence of symbols on the basis of the other estimates of the fifth sequence; and
- decoding the sixth sequence of estimates and outputting the decoded estimates.

The DTX bits can be taken into account without any problem. In the case where the TrCHs have variable positions in the frame, the formation of the third sequence then comprises a concatenating of the second sequences which are formed for the Y communication channels and a deleting of at least one estimate having a determined position in the concatenated sequence. In the case where the TrCHs have fixed positions in the frame, the formation of the fifth sequence for the one transmission time interval including this frame in relation to a transport channel comprises a deleting of

at least one estimate having a determined position in the fourth permuted sequence.

The invention also proposes a device adapted to the implementation of this method, which can form part
5 of a UMTS terminal, and comprising:

- 10 - means for forming, for each frame in relation to each communication channel, a first sequence composed of estimates extracted from the time slots of the said frame and, when the said frame is in compressed mode, marked estimates placed at positions corresponding to the inactive period of the said frame;
- 15 - means for forming, for each frame in relation to each communication channel, a second sequence of estimates by permutation of the estimates of the first sequence;
- 20 - means for forming, for each frame, a third sequence of estimates including estimates of the second sequence which is output for each communication channel;
- 25 - means for distributing the estimates of the third sequence formed for each frame into X segments of consecutive estimates, the X segments being respectively assigned to the X transport channels;
- 30 - means for forming a fourth sequence for each transmission time interval relating to a transport channel, by concatenating the respective segments assigned to the said transport channel for the frames of the said transmission time interval;
- 35 - means for permuting the estimates of the fourth sequence which is formed for each transmission time interval relating to a transport channel i, and for forming a fifth sequence of estimates extracted from the fourth permuted sequence;
- means for deleting each marked estimate of the fifth sequence which is formed for each

transmission time interval relating to a transport channel i , and for forming a sixth sequence of symbols on the basis of the other estimates of the fifth sequence; and

- 5 - means for decoding the sixth sequence of estimates which is formed for each transmission time interval relating to a transport channel, so as to output the decoded estimates.

10 Other features and advantages of the present invention will appear in the following description of nonlimiting exemplary embodiments, with reference to the appended drawings, in which:

- 15 - Figure 1, commented on earlier, is a diagram illustrating the frame structure employed on the downlinks in the UMTS system in FDD mode;
- Figures 2 and 3, commented on earlier, are schematic diagrams of a base station and of a UMTS terminal to which the invention may be applied;
- 20 - Figures 4 and 5, commented on earlier, are schematic diagrams of the multiplexing and demultiplexing blocks of the base station and of the terminal according to Figures 2 and 3;
- Figures 6 and 7 are flow charts of procedures which can be used to carry out the bit rate matching on the TrCHs in the multiplexing block according to Figure 4, in the case of the use of a convolutional code;
- 25 - Figures 8 and 9 are flow charts respectively showing modifications made to the procedures of Figures 6 and 7 in accordance with two embodiments of the invention;
- 30 - Figures 10 and 11 are flow charts similar to Figures 6 and 8 for the case where the information bits of the TrCH are protected by a turbo code.
- 35

The invention is described hereinbelow within the context described earlier of the UMTS downlinks in FDD mode. In the examples considered below, the

modifications made by the invention occur essentially at the level of the bit rate matching modules 24_i , 44_i and of the modules 32_j , 52_j for interfacing with the PhCHs.

5 We firstly consider the case of a TrCH i ($1 \leq i \leq X$) for which the module 23_i applies a convolutional code. In this case, the output bits from the coder all have the same relative importance to the decoder. Figures 6 and 7 show an exemplary embodiment of the
10 procedures applied by the bit rate matching module 24_i in the case of a puncturing and of a repetition of bits, respectively.

These procedures use parameters e_{plus} and e_{minus} defined as a function of the numbers of bits E_i , G_i at the input and at the output of the module 24_i , with $G_i <$
15 E_i in the case of puncturing (Figure 6), and $G_i > E_i$ in the case of repetition (Figure 7). The values of these parameters are:

$$e_{plus} = a \cdot E_i$$
$$e_{minus} = a \cdot |G_i - E_i| = a \cdot |\Delta N_i^{TTI}|$$

20

with $a = 2$. The numbers E_i , G_i are determined as a function of the information provided by the higher protocol layers as described in the specification 3G TS 25.212. The variation in the number of bits, due to the
25 static bit rate matching is denoted ΔN_i^{TTI} . In noncompressed mode, we have $\Delta N_i^{TTI} = G_i - E_i$. Within the notation used in Figures 6 and 7, m designates the index of the symbols $c_{i,m}$ in the input sequence c_i ($1 \leq m \leq E_i$), n designates the index of the symbols $g_{i,n}$ in the
30 output sequence g_i ($1 \leq n \leq G_i$), and e designates a counter decremented and incremented to ensure a regular apportioning of the punctured or repeated bits. We take $m = n = 1$ and $e = E_i$ on initializing 60 the procedure.

A loop is executed for the successive values of
35 the index m , lying between 1 and E_i . Each iteration in this loop begins with the decrementing 63 of the counter e by the value e_{minus} . The bit $c_{i,m}$ is punctured or repeated whenever $e \leq 0$ during the test 64, in which

case the counter e is incremented in step 65 by the value e_{plus} .

In the case of puncturing (Figure 6), the test 64 is performed just after the decrementing 63 of the counter e in each iteration. When $e > 0$ in the test 64, the bit $c_{i,m}$ should not be punctured, and step 66 is executed so as to place this bit $c_{i,m}$ in position n in the output sequence g_i and to increment the index n by one unit. The iteration terminates with the end of loop test 67 after step 65 or 66. The bit rate matching procedure is terminated when $m = E_i$. Otherwise, m is incremented by one unit in step 68 before returning to step 63 for the next iteration.

The procedure is similar for repetition (Figure 7), with the following differences:

- the step 66 of placing the bit $c_{i,m}$ in the output sequence and of incrementing the index n precedes the test 64 pertaining to the sign of the counter e ;
- this step 66 is executed for all the bits of the input sequence (after step 63), and re-executed whenever a bit must be repeated (after step 65);
- when the bit has been repeated sufficiently ($e > 0$ in test 64), the iteration terminates with the end of loop test 67.

The invention proposes to adapt the procedures of Figures 6 and 7 to the case of the compressed mode, with a minimum impact on the remainder of the multiplexing suite. This is performed by placing marked bits "p" at judiciously chosen positions in the input sequence of the inter-frame interleaver 26_i for each TrCH i .

In the implementation considered above, this marking can consist in replacing each "p" bit by the two-bit symbol (1, 1), which remains available when the marking (1, 0) is reserved for the "δ" bits. It will however be observed that the marking of the "p" bits could be the same as that of the "δ" bits.

The marking of the "p" bits before the interleaver 26_i makes it possible to carry out downstream in the suite the additional puncturing required by the compressed modes. Preferably, this additional puncturing is performed at the level of the modules 32_j relating to the Y PhCH: these modules tag the "p" marked bits, position them at the level of the required interruption and do not transmit them to the radio stage 4 (or transmit bits set to zero instead of signed bits). This makes it possible to use the modules 25_i to 31_j in the same way in compressed mode and in noncompressed mode.

At the level of the receiver terminal, the modifications to be made in order to support the compressed mode are also minor:

- for each frame and each PhCH j, the extraction module 52_j completes the softbits r'_j by placing marked softbits at the positions corresponding to the "p" marked bits. These marked softbits "p" have a particular value which is not employed for the other softbits, for example 0xFF for softbits of a byte. The positions of the softbits to be marked are immediately determinable: they correspond to the DATA1 and DATA2 fields not transmitted during the interruption when the frame is in compressed mode. The number N_j^{TGL} of marked softbits "p" is simply the difference between the number of bits processed on channel j in a frame in noncompressed mode and the number of bits processed in channel j in the current frame (N_j^{TGL} > 0 in compressed mode, and N_j^{TGL} > 0 in noncompressed mode);
- the modules 51_j to 45_i work in the same way in noncompressed mode and in compressed mode;
- at the input of the bit rate matching modules 44_i, which operate as described earlier, the marked softbits "p" are detected and deleted from the sequence g'_i. The module 44_i does not

need to know a priori the positions of the bits of the TrCH i which have undergone the additional puncturing;

- the modules 43 _{i} to 41 _{i} work in the same way in noncompressed mode and in compressed mode.

The number of bits of TrCH i per frame after the static bit rate matching is denoted $Nfr_i = (E_i + \Delta N_i^{TTI})/F_i$, and the number of bits having to be marked "p" in frame n_i belonging to the TTI of this TrCH ($0 \leq n_i \leq F_i$) is denoted $-\Delta N_i^{cm}[n_i]$. In compressed mode, the positive number $-\Delta N_i^{cm}[n_i]$ depends on the position and on the duration of the interruption in the course of frame n_i of the TTI, on spreading factors pertaining to the Y physical channels and on the amounts of static bit rate matching already carried out in the X TrCH of the communication. When the frame is not in compressed mode, $\Delta N_i^{cm}[n_i] = 0$. The total number $-\Delta N_i^{cm}$ of bits of the TTI to be marked "p" is given by
$$\Delta N_i^{cm} = \sum_{n_i=0}^{F_i-1} \Delta N_i^{cm}[n_i].$$
 Finally, the sequence g_i of G_i bits which

is output for the TTI by the module 24 _{i} comprises $E_i + \Delta N_i^{TTI} + \Delta N_i^{cm}$ symbols representing bits extracted from sequence c_i and $-\Delta N_i^{cm}$ marked symbols "p".

A first manner of proceeding at the level of the base station (method 1 hereinbelow) consists, for each TrCH and each TTI of this TrCH comprising at least one frame in compressed mode, in identifying the bits which will be found in the compressed-mode frame or frames after the other operations, in particular of interleaving, executed in the multiplexing suite. An algorithm of the same kind as that of Figure 6 is then executed on these identified bits so that some of them are marked "p".

Figure 8 illustrates an embodiment according to this method 1, showing steps 70-76 replacing step 66 in the procedure according to Figure 6 or 7. The parameters e_{plus} and e_{minus} for the bit rate matching are defined as earlier ($e_{plus} = a \cdot E_i$ and $e_{minus} = a \cdot |\Delta N_i^{TTI}|$),

and parameters of the same nature are moreover defined for the additional puncturing in each TrCH i and each frame n_i belonging to the TTI of this TrCH:

$$e_{\text{plus}}^{\text{cm}}[n_i] = a' \cdot \text{Nfr}_i$$

5 $e_{\text{minus}}^{\text{cm}}[n_i] = -a' \cdot \Delta N^{\text{cm}}[n_i]$

with $a' = 2$ (for example), and additional counters $e^{\text{cm}}[n_i]$ are initialized to Nfr_i in step 60. In step 70, the index col of that frame of the TTI in which the symbol $g_{i,n}$ will be found (column of the interleaver 26 _{i} after permutation) is calculated using the function BR defined earlier. If this frame is not in compressed mode ($\Delta N^{\text{cm}}[col] = 0$ in test 71), the symbol $g_{i,n}$ receives the value $(0, c_{i,m})$ in step 72, then the index n is incremented by one unit in the final step 73. If the
10 frame is in compressed mode ($\Delta N^{\text{cm}}[col] < 0$ in test 71), the counter $e^{\text{cm}}[col]$ is decremented by the value $e_{\text{minus}}^{\text{cm}}[col]$. When $e^{\text{cm}}[col] \leq 0$ during test 75, the symbol $g_{i,n}$ is marked "p" in step 76 (the bit $c_{i,m}$ will be punctured), in which case the counter $e^{\text{cm}}[col]$ is
15 incremented by the value $e_{\text{plus}}^{\text{cm}}[col]$ before incrementing the index n in the final step 73. When $e^{\text{cm}}[col] > 0$ during test 75, the module 24 goes to the aforesaid step 72 to assign the value $(0, c_{i,m})$ to the symbol $g_{i,n}$ which will be kept in the compressed-mode frame.

25 Another way of proceeding at the base station level (method 2 hereinbelow) consists, for each TrCH i and each TTI of this TrCH comprising at least one compressed-mode frame, in applying the bit rate matching algorithm according to Figure 6 or 7 to the
30 sequence of bits c_i , while taking into account, in the number ΔN_i of bits to be punctured or repeated, both the static bit rate matching (ΔN_i^{TTI}) and any possible compressed mode (ΔN_i^{cm}), and in adding the ΔN_i^{cm} marked bits "p" into the first positions of the columns
35 corresponding to compressed-mode frames. This makes it possible to optimize the distance between the punctured or repeated information bits. Four cases arise:

- 1) $\Delta N_i^{\text{TTI}} < 0$, so that $\Delta N_i = \Delta N_i^{\text{TTI}} + \Delta N_i^{\text{cm}} < 0$. The puncturing rate is simply increased.

- 2) $\Delta N_i^{TTI} < 0$ and
 $\Delta N_i^{TTI} > 0$ and $|\Delta N_i^{cm}| > \Delta N_i^{TTI}$ so that $\Delta N_i < 0$. Despite
the repetition due to the static bit rate
matching, bits will nevertheless have to be
punctured. Hence, nothing is repeated, ΔN bits
are punctured and $-\Delta N_i^{cm}$ marked bits ("p") are
inserted.
- 3) $\Delta N_i^{TTI} > 0$ and $|\Delta N_i^{cm}| < \Delta N_i^{TTI}$ so that $\Delta N_i > 0$. There
is no need to puncture unique information bits.
It is sufficient to repeat less than what is
demanded by the static bit rate matching.
Hence, ΔN bits are repeated and $-\Delta N_i^{cm}$ marked
bits ("p") are inserted.
- 4) $\Delta N_i^{TTI} > 0$ and $|\Delta N_i^{cm}| = \Delta N_i^{TTI}$ so that $\Delta N = 0$. There
is no need either to puncture or to repeat
information bits. It is sufficient to insert -
 ΔN_i^{cm} marked bits ("p").

Figure 9 illustrates an embodiment according to
this method 2, by showing steps 80-83 replacing step 66
in the procedure according to Figure 6 or 7. The
parameters e_{plus} and e_{minus} for the bit rate matching are
defined by:

$$e_{plus} = a \cdot E_i$$
$$e_{minus} = a \cdot |\Delta N_i^{TTI} + \Delta N_i^{cm}|$$

and F_i additional counters $cbi[n_i]$ are used which
enumerate the bits "p" inserted at the start of the
columns of the interleaver ($0 \leq n_i < F_i$). These counters
 $cbi[n_i]$ are initialized to 0 in step 60. In step 80,
the index col of that frame of the TTI in which the
symbol $g_{i,n}$ will be found (column of the interleaver 26_i
after permutation) is calculated using the function BR.
If $cbi[col] < \Delta N^{cm}[col]$ (test 81), step 82 is executed
so as to insert a bit "p" in position n of the output
sequence g_i and to increment the counter $cbi[col]$ and
the index n by one unit, after which the module 24_i
returns to step 80 for the next position. When $cbi[col]$
 $= \Delta N^{cm}[col]$ in test 81 (that is to say the frame is not
in compressed mode since $\Delta N^{cm}[col] = 0$, or all the bits
"p" required have been introduced into the compressed-

mode frame), the final step 83 is executed so as to write the bits $c_{i,m}$ (with the prefix 0) into the symbol $g_{i,n}$ and to increment the index n by one unit.

5 In the case where the channel coding module 23_i uses a turbo code with the rate 1/3, the puncturing procedure is applied by the bit rate matching module 24_i only to the parity bits. This is illustrated by Figure 10. The procedure is similar to that of Figure 6, identical numeral references being employed to
10 designate homologous steps.

The counter e of Figure 6 is replaced by two counters e_1, e_2 assigned respectively to the bits $c_{i,1+3x+k}$ with $k = 1$ and $k = 2$. These two counters are initialized to $E_i/3$ in step 60. The processing of these
15 counters calls upon parameters:

$$e_{k,plus} = a_k \cdot E_i / 3$$
$$e_{k,minus} = a_k \cdot \lfloor \Delta N_{k,i}^{TTI} \rfloor$$

with $a_1 = 2$ and $a_2 = 1$, $\Delta N_{1,i}^{TTI}$ and $\Delta N_{2,i}^{TTI}$ respectively designating the largest integer equal to or less than
20 $\Delta N_i^{TTI}/2$ and the smallest integer equal to or less than $\Delta N_i^{TTI}/2$.

In step 61, the pointer k is determined for the current index m (this is the remainder of the Euclidean division of $m-1$ by 3). If $k = 0$ (test 62), the bit $c_{i,m}$
25 is systematic and should not be punctured: we go to step 66. When $k = 1$ or 2 in test 62, steps 63-66 are executed as in the case of Figure 6 by manipulating the counter e_k instead of the counter e so as to puncture the appropriate bits.

30 In practice, the procedure of Figure 10 can be executed by separating the sequence c_i into two subsequences: the systematic bits ($c_{i,3x}$) which are not subjected to puncturing, and the other bits to which the procedure as described with reference to Figure 6
35 is applied, with appropriately adapted parameters, the sequence g_i then being constructed by reinserting the systematic bits.

Figure 11 shows steps adapted for replacing step 66 of Figure 10 in the application of method 1 to

the case of puncturing with a turbo code. Steps 70-76 are entirely similar to those bearing the same references in Figure 6, and are executed only if $k = 1$ or 2 in the initial test 69. If $k = 0$, we go directly to step 72 so as to avoid puncturing the systematic bit. Steps 74-76 use, instead of the counters $e^{cm}[n_i]$, counters $e_k^{cm}[n_i]$ for $k = 1, 2$ and $n_i = 0, 1, \dots, F_i - 1$, which are initialized to $Nfr_{k,i} = (E_i/3 + \Delta N_{k,i}^{TTI})/F_i$ in step 60. The processing of these counters calls upon puncturing parameters:

$$e_{k,plus}^{cm}[col] = a_k \cdot Nfr_{k,i}$$
$$e_{k,minus}^{cm}[col] = -a_k \cdot \Delta N_k^{cm}[n_i],$$

the positive or zero integer $-\Delta N_k^{cm}[n_i]$ representing the number of parity bits k to be punctured in the course of frame n_i of the TTI ($\Delta N_1^{cm}[n_i] + \Delta N_2^{cm}[n_i] = \Delta N^{cm}[n_i]$).

In the case of repetition with a turbo code, the bit rate matching algorithm is the same as that of Figure 7. The compressed mode can be taken into account according to method 1 by replacing step 66 of Figure 7 by steps 69-76 of Figure 11.

For the application of method 2 to the case of turbo codes (repetition or puncturing), it is sufficient to replace step 66 of Figure 7 or 10 by steps 80-83 of Figure 9.

The appendix to the present description provides a C pseudocode corresponding to an exemplary bit rate matching algorithm applied by the module 24; in accordance with the present invention (method 2).

A P P E N D I X

- $e_{ini}[]$ Initial value of variable e in the rate matching pattern determination algorithm.
- $e_{ini}[1]$: initial value for convolutional codes and for turbo codes Parity-1 bits
- $e_{ini}[2]$: initial value for turbo codes Parity-2 bits
- $e_{plus}[]$ Increment of variable e in the rate matching pattern determination algorithm.
- $e_{plus}[1]$: Increment of variable e in the rate matching for convolutional codes and for turbo codes Parity-1 bits
- $e_{plus}[2]$: Increment of variable e in the rate matching for turbo codes Parity-2 bits
- $e_{minus}[]$ Decrement of variable e in the rate matching pattern determination algorithm.
- $e_{minus}[1]$: Decrement of variable e in the rate matching for convolutional codes and for turbo codes Parity-1 bits
- $e_{minus}[2]$: Decrement of variable e in the rate matching for turbo codes Parity-2 bits

Initialisation:

ΔN_{ij}^{cm} : Negative or null: number of bits to be removed to create the required gaps in the compressed frames of the transmission time interval in case of compressed mode, in each transmission time interval on TrCH i with transport format j .

$\Delta N^{cm} []$: Negative or null: number of bits to be removed in each frame of the TTI, to create if needed the required gaps in this frame in each transmission time interval on TrCH i with transport format j . The value will be null for the un-compressed frames. The size of this array is F , the number of frames in the TTI.

For convolutional codes:

$$\Delta N_i = \Delta N_{it}^{TTI} + \Delta N_{cm};$$

$$X_i = N_{it}^{TTI};$$

$$e_{ini}[1] = 1;$$

$$e_{plus}[1] = 2 N_{it}^{TTI};$$

$$e_{minus}[1] = 2 |\Delta N_i|$$

puncturing part of algorithm is applied if $\Delta N_i \leq 0$, repetition is applied otherwise.

For Turbo Codes:

$$\Delta N_i [1] = \text{round down} (\Delta N_{it}^{TTI}/2) + \text{round up} (\Delta N_{cm}/2), \text{ if Y' sequence}$$

$$\Delta N_i [2] = \text{round up} (\Delta N_{it}^{TTI}/2) + \text{round down} (\Delta N_{cm}/2), \text{ if Y sequence}$$

$$X_i = N_{it}^{TTI} / 3;$$

$$e_{ini}[1] = X_i;$$

$$e_{ini}[2] = X_i;$$

$$e_{plus}[1] = 2 X_i;$$

$$e_{plus}[2] = X_i;$$

$$e_{minus}[1] = 2 |\Delta N_i [1]|;$$

$$e_{minus}[2] = |\Delta N_i [2]|$$

puncturing part of algorithm is applied if $\Delta N_i [1] \leq 0$ or $\Delta N_i [2] \leq 0$, repetition part is applied otherwise

Algorithm:

```
c [1] = eini [1] -- initial error between current and desired puncturing ratio
α = 1 -- parameter for the range of index m
if Turbo Codes then
    c [2] = eini [2]
    if puncturing is needed then α = 2 else α = 3 endelse
endif
m = 1 -- index of current bit in the information bit flow (input flow)
n = 1 -- index of bit in the output flow before first interleaver
for i = 0 to F-1 do cbi[i] = 0 -- initiate counter of number of bits inserted in
                           each frame of the TTI
    if puncturing is to be performed do while m ≤ α Xi
        if Turbo Codes then
            c = m mod 2 -- c = 1 if Parity-1 bit, c = 2 if Parity-2 bit
            if (c=1) then n = n+1 endif -- in output flow increment output
                                     index to take into account bit X
        else
            c = 1
        endelse
    endwhile
endfor
```

- 31 -

```
[c]= e[c] - e_minus [c] -- update error
if e[c] <= 0 then -- check if bit number m should be punctured
    set bit  $x_{i,m}$  to  $\delta$  where  $\delta \in \{0, 1\}$ 
    e[c] = e[c] + e_plus[c] -- update error
else
    col = BR[ (n-1) mod F] -- calculate index of column where this bit will go
    while cbi[col] <  $\Delta N^{cm}$  [col] do
        insert one bit marked « p » in output position n -- insert marked bit to be
                                                                removed in compressed
                                                                frame when creating the
                                                                gap
        n = n + 1 -- update output index since 1 bit is inserted
        cbi[col] = cbi[col] + 1 -- update counter of bits p inserted in this column
        col = BR[ (n-1) mod F] -- update column value of next position
    enddo
    n = n + 1 -- update output index, since bit  $x_m$  was not punctured
endelse
m = m + 1 -- next bit
end do
else
do while m <=  $\alpha X_i$ 
    e = e - e_minus -- update error
    col = BR[(n-1) mod F]
    while cbi[col] <  $\Delta N^{cm}$  [col] do
        insert one bit marked p in position n
```

- 32 -

```
n = n + 1      -- update output index

cbi[col] = cbi[col] + 1 -- update counter of bits p inserted in this column

col = BR[(n-1) mod F] -- update column value of next position

enddo

do while e <= 0      -- check if bit number m should be repeated

    col = BR[(n-1) mod F] -- calculate column where the current
                          position will go

    while cbi[col] <  $\Delta N^{cm}[col]$  do

        insert one bit marked p

        n = n + 1      -- update output index since 1 bit has been inserted

        cbi[col] = cbi[col] + 1 -- update counter of bits p inserted in this column

        col = BR[(n-1) mod F] -- update column value of next position

    enddo

    repeat bit  $x_{i,m}$ 

    n = n + 1      -- update output index since bit has been repeated

    e = e +  $e_{plus}$  -- update error

    end do

    m = m + 1      -- next bit

end do

end if
```

CLAIMS

1. Method of processing X streams of information symbols to be transmitted on Y communication channels, X and Y being positive integers, in which the Y communication channels simultaneously occupy a transmission resource organized as successive frames, in which the successive frames include compressed-mode frames having at least one inactive period during which no symbol is transmitted, in which the information symbols of each stream i ($1 \leq i \leq X$) are transmitted in the course of successive transmission time intervals each comprising F_i consecutive frames, F_i being a positive integer, and in which, for each transmission time interval relating to a stream i ($1 \leq i \leq X$), integers E_i , ΔN_i^{TTI} and ΔN_i^{cm} are defined such that $E_i > 0$, $\Delta N_i^{cm} < 0$ if the said transmission time interval comprises at least one compressed-mode frame and $\Delta N_i^{cm} = 0$ if the said transmission time interval does not comprise any compressed-mode frame, the method comprising the following steps for each transmission time interval relating to a stream i ($1 \leq i \leq X$):
- forming a first sequence (c_i) of E_i symbols coded on the basis of information symbols of the said stream pertaining to the said transmission time interval;
 - forming a second sequence of symbols (h_i) including $E_i + \Delta N_i^{TTI} + \Delta N_i^{cm}$ symbols extracted from the first sequence and $-\Delta N_i^{cm}$ marked symbols;
 - forming a third sequence of symbols (q_i) by a permutation of the symbols of the second sequence;
 - distributing the symbols of the third sequence into F_i segments of consecutive symbols, the F_i segments being respectively assigned to the frames of the said transmission time interval; and
 - for each frame of the said transmission time interval, forming a fourth sequence (f_i) of

symbols extracted from the segment assigned to the said frame,

the said permutation and the placing of the marked symbols in the second sequence when the said transmission time interval comprises at least one compressed-mode frame being such that each marked symbol belongs, in the third sequence, to a segment assigned to a compressed-mode frame, and the following steps for each frame:

- 10 - forming a fifth sequence of symbols (w) including the symbols of the fourth sequence output for the said frame in relation to each stream;
- distributing the symbols of the fifth sequence into Y segments of symbols, the Y segments being respectively assigned to the Y communication channels;
- 15 - for each communication channel, forming a sixth sequence (u_j) of symbols extracted from the segment assigned to the said communication channel;
- 20 - for each communication channel, forming a seventh sequence of symbols (v_j) by a permutation of the symbols of the sixth sequence; and
- transmitting on each communication channel, in time slots of the said frame, symbols extracted from the seventh sequence,
- 25

each of the said marked symbols being deleted before transmission on each communication channel when the said frame is in compressed mode, so as to husband the said inactive period in the course of the frame.

30 2. Method according to Claim 1, in which the said marked symbols are kept until the seventh sequences (v_j) when the said frame is in compressed mode, without being extracted from the seventh sequences for transmission.

35 3. Method according to Claim 1 or 2, in which additional marked symbols are inserted into the second or the fifth sequence (h_i, w), these symbols being kept

until the seventh sequences (v_j) so as to be transmitted with zero transmission power.

4. Device for processing X streams of information symbols to be transmitted on Y communication channels, X and Y being positive integers, the Y communication channels simultaneously occupying a transmission resource organized as successive frames, the successive frames including compressed-mode frames having at least one inactive period during which no symbol is transmitted, the information symbols of each stream i ($1 \leq i \leq X$) being transmitted in the course of successive transmission time intervals each comprising F_i consecutive frames, F_i being a positive integer, integers E_i , ΔN_i^{TTI} and ΔN_i^{cm} being defined for each transmission time interval relating to a stream i ($1 \leq i \leq X$), with $E_i > 0$, $\Delta N_i^{\text{cm}} < 0$ if the said transmission time interval comprises at least one compressed-mode frame and $\Delta N_i^{\text{cm}} = 0$ if the said transmission time interval does not comprise any compressed-mode frame, the device comprising:

- means (21_i-23_i) for forming a first sequence (c_i) of E_i coded symbols on the basis of information symbols of each stream i ($1 \leq i \leq X$) pertaining to a transmission time interval;
- 25 - means (24_i-25_i) for forming, for each transmission time interval relating to a stream i ($1 \leq i \leq X$), a second sequence of symbols (h_i) including $E_i + \Delta N_i^{\text{TTI}} + \Delta N_i^{\text{cm}}$ symbols extracted from the first sequence and $-\Delta N_i^{\text{cm}}$ marked symbols;
- 30 - means (26_i) for forming a third sequence of symbols (q_i) by a first permutation of the symbols of each second sequence;
- means (27_i) for distributing the symbols of each third sequence, which is formed for a transmission time interval relating to a stream i ($1 \leq i \leq X$), into F_i segments of consecutive symbols respectively assigned to the frames of the said transmission time interval, and for forming F_i fourth sequences (f_i) of symbols respectively

- extracted from the segments assigned to the said frames;
- means (28-29) for forming, for each frame, a fifth sequence of symbols (w) including the symbols of the fourth sequence output for the said frame in relation to each stream i ($1 \leq i \leq X$);
 - means (30) for distributing the symbols of each fifth sequence into Y segments of symbols respectively assigned to the Y communication channels;
 - means (31_j) for forming a sixth sequence (u_j) of symbols extracted from the segment assigned to each communication channel; and
 - means (32_j) for forming a seventh sequence of symbols (v_j) by a second permutation of the symbols of each sixth sequence, and for transmitting, in time slots of each frame on each communication channel, symbols extracted from the seventh sequence,
- in which the first permutation and the placing of the marked symbols in the second sequence, which is formed for a transmission time interval relating to a stream when the said transmission time interval comprises at least one compressed-mode frame, are such that each marked symbol belongs, in the third sequence which is formed for the said transmission time interval, to a segment assigned to a compressed-mode frame, each of the said marked symbols being deleted before transmission on each communication channel so as to husband the said inactive period in the course of the frame.
5. Device according to Claim 4, in which the means (26_i-32_j) for forming the third, fourth, fifth, sixth and seventh sequences of symbols (q_i , f_i , w , u_j , v_j) are configured so as to keep the said marked symbols until the seventh sequences (v_j) which are formed for each compressed-mode frame, the said marked symbols not being extracted from the seventh sequences for transmission.

6. Device according to Claim 4 or 5, comprising means (25_i, 29) for inserting, into the second or fifth sequences (h_i, w), additional marked symbols which are kept until the seventh sequences (v_j) so as to be transmitted with zero transmission power.

7. Radiocommunication base station comprising a processing device according to any one of Claims 4 to 6.

8. Method of processing Y digital streams (r'_j) obtained on the basis of a signal received and comprising estimates of information symbols respectively transmitted along Y communication channels simultaneously occupying a transmission resource organized as successive frames, and pertaining to X transport channels, X and Y being positive integers, in which the successive frames include compressed-mode frames having at least one inactive period during which no symbol is transmitted, and in which the estimates of information symbols pertaining to each transport channel i (1 ≤ i ≤ X) are received in the course of successive transmission time intervals each comprising F_i consecutive frames, F_i being a positive integer, the method comprising the following steps for each frame:

- 25 - forming, in relation to each communication channel j (1 ≤ j ≤ Y), a first sequence (v'_j) composed of estimates extracted from the time slots of the said frame and, when the said frame is in compressed mode, of marked estimates placed at
- 30 positions corresponding to the inactive period of the said frame;
- for each communication channel, forming a second sequence of estimates (u'_j) by a permutation of the estimates of the first sequence;
- 35 - forming a third sequence of estimates (s') including estimates of the second sequence which is output for each communication channel; and
- distributing the estimates of the third sequence into X segments (f'_i) of consecutive estimates,

the X segments being respectively assigned to the X transport channels, and the following steps for each transmission time interval relating to a transport channel;

- 5 - forming a fourth sequence (q'_i) by concatenating the respective segments (f'_i) assigned to the said transport channel for the frames of the said transmission time interval;
 - permuting the estimates of the fourth sequence and forming a fifth sequence (g'_i) of estimates extracted from the fourth permuted sequence (h'_i);
 - 10 - ignoring each marked estimate of the fifth sequence, and forming a sixth sequence of symbols (c'_i) on the basis of the other estimates of the fifth sequence; and
 - 15 - decoding the sixth sequence of estimates and outputting the decoded estimates (a'_i).
9. Method according to Claim 8, in which the forming of the third sequence (s') for at least one frame comprises a concatenating of the second sequences (u'_j) which are formed for the Y communication channels and a deleting of at least one estimate having a determined position in the concatenated sequence (w').
- 20 10. Method according to Claim 8, in which the formation of the fifth sequence (g'_i) for at least one transmission time interval relating to a transport channel comprises a deleting of at least one estimate having a determined position in the fourth permuted sequence (h'_i).
- 25 11. Device for processing Y digital streams (r'_j) obtained on the basis of a signal received and comprising estimates of information symbols respectively transmitted along Y communication channels simultaneously occupying a transmission resource
- 30 organized as successive frames, and pertaining to X transport channels, X and Y being positive integers, the successive frames including compressed-mode frames having at least one inactive period during which no symbol is transmitted, and the estimates of information
- 35

symbols pertaining to each transport channel i ($1 \leq i \leq X$) being received in the course of successive transmission time intervals each comprising F_i consecutive frames, F_i being a positive integer, the device comprising:

- 5 - means (52_j) for forming, for each frame in relation to each communication channel, a first sequence (v'_j) composed of estimates extracted from the time slots of the said frame and, when
10 the said frame is in compressed mode, marked estimates placed at positions corresponding to the inactive period of the said frame;
- means (51_j) for forming, for each frame in relation to each communication channel, a second
15 sequence of estimates (u'_j) by permutation of the estimates of the first sequence;
- means (50, 49) for forming, for each frame, a third sequence of estimates (s') including
20 estimates of the second sequence which is output for each communication channel;
- means (48) for distributing the estimates of the third sequence formed for each frame into X
segments (f'_i) of consecutive estimates, the X segments being respectively assigned to the X
25 transport channels;
- means (47_i) for forming a fourth sequence (q'_i) for each transmission time interval relating to a
transport channel, by concatenating the respective segments (f'_i) assigned to the said transport
30 channel for the frames of the said transmission time interval;
- means (46_i, 45_i) for permuting the estimates of the fourth sequence which is formed for each
transmission time interval relating to a transport channel, and for forming a fifth sequence (g'_i) of
35 estimates extracted from the fourth permuted sequence (h'_i);
- means (44_i) for deleting each marked estimate of the fifth sequence which is formed for each

transmission time interval relating to a transport channel, and for forming a sixth sequence of symbols (c'_i) on the basis of the other estimates of the fifth sequence; and

5 - means (43_i-41_i) for decoding the sixth sequence of estimates which is formed for each transmission time interval relating to a transport channel, so as to output the decoded estimates (a'_i).

12. Device according to Claim 11, in which the
10 means for forming the third sequence of estimates (s') comprise means (50) for concatenating the second sequences (u'_j) which are formed for the Y communication channels and means (49) for deleting at least one estimate having a determined position in the
15 concatenated sequence (w').

13. Device according to Claim 11, in which the means for forming the fifth sequence (g'_i) comprise means (45_i) for deleting at least one estimate having a determined position in the fourth permuted sequence
20 (h'_i).

14. Radiocommunication terminal, comprising a processing device according to any one of Claims 11 to 13.

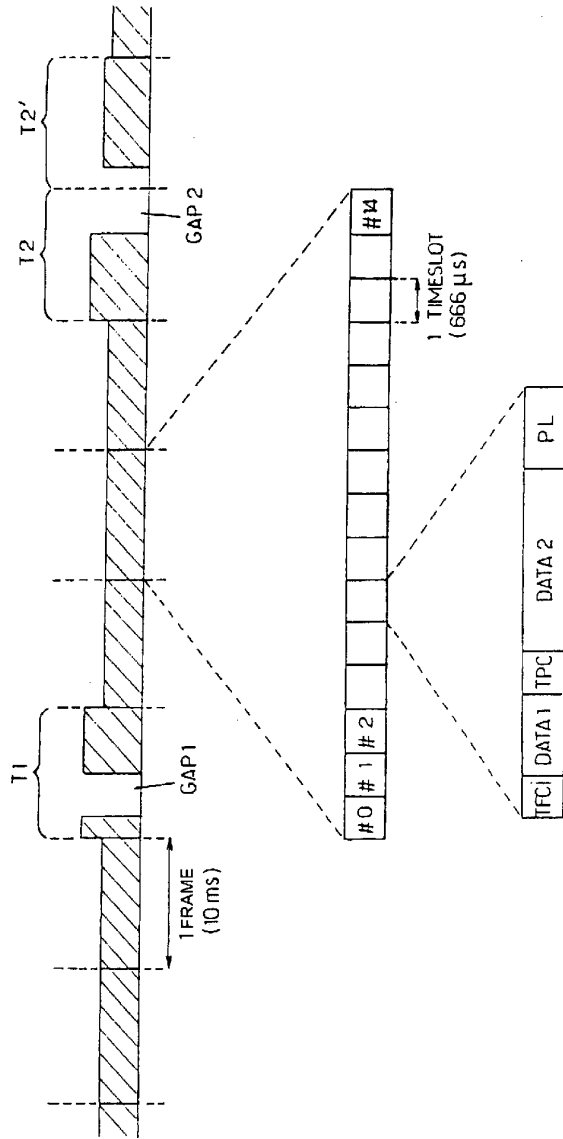

FIG. 1.

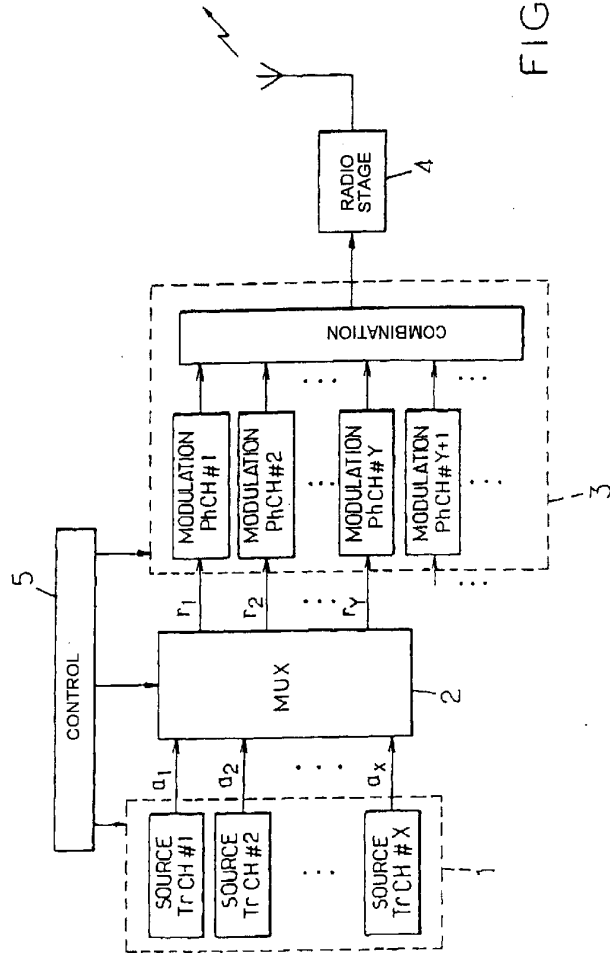

FIG. 2.

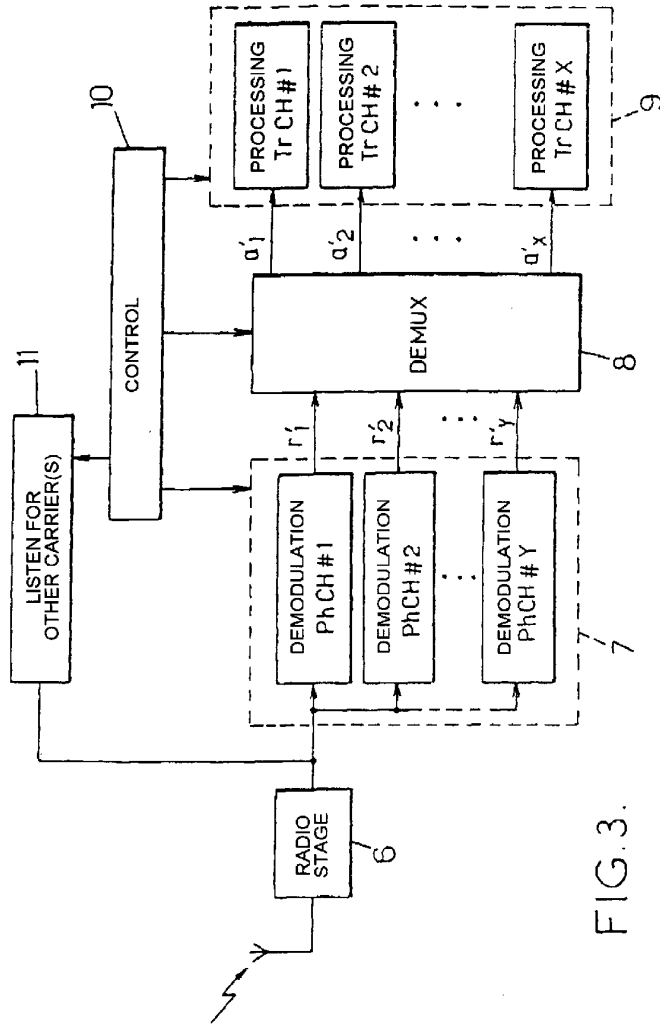

FIG. 3.

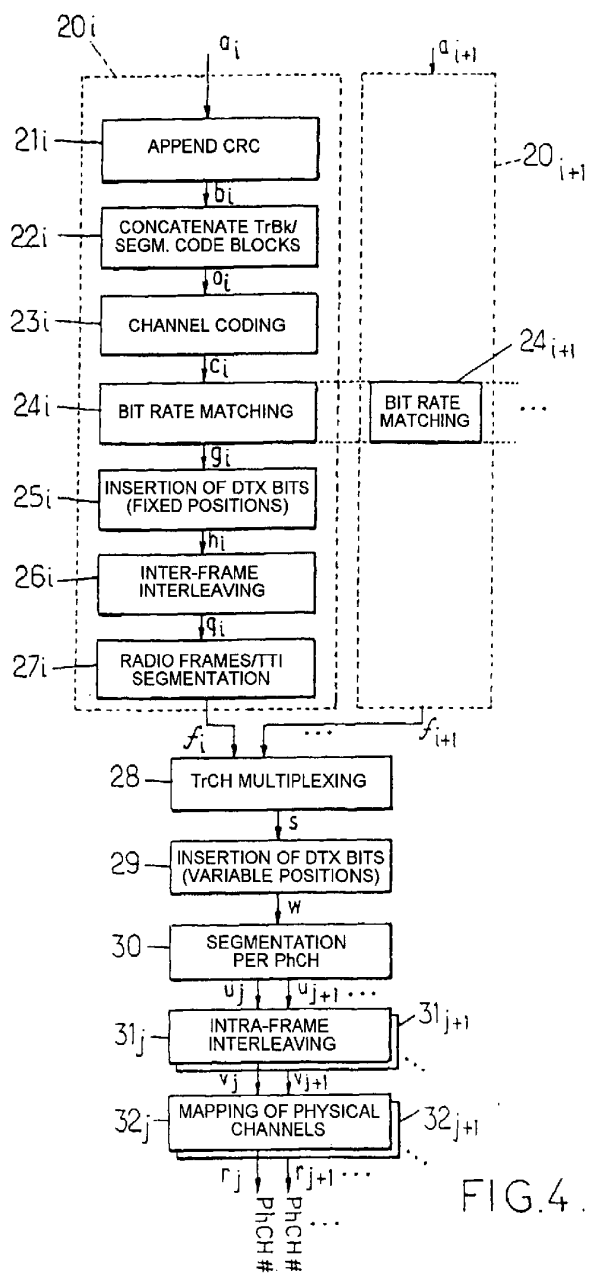
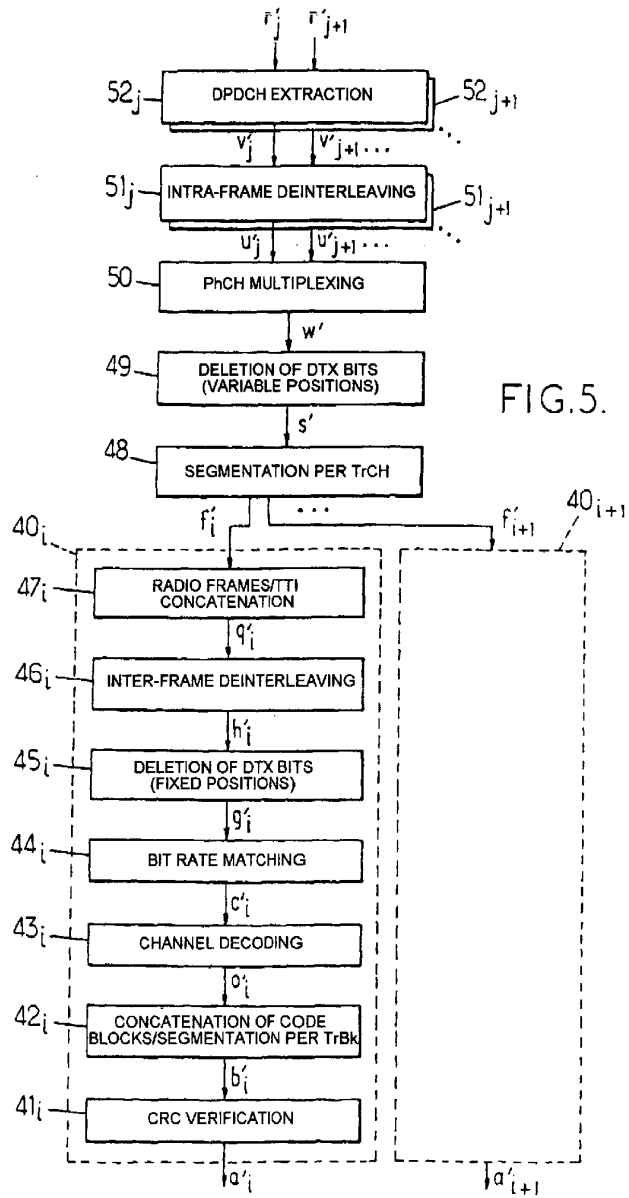

FIG.4.



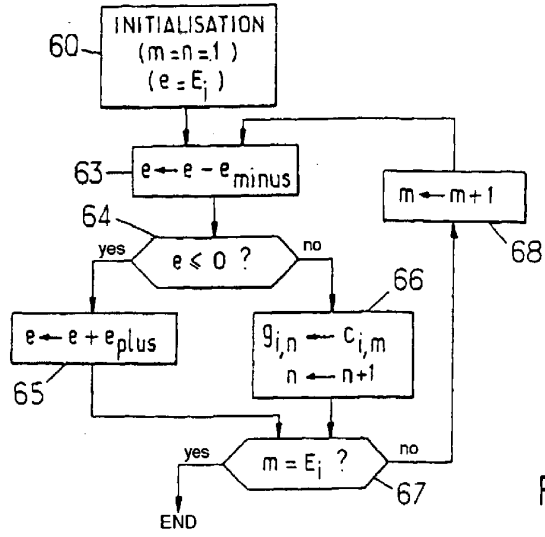

FIG. 6

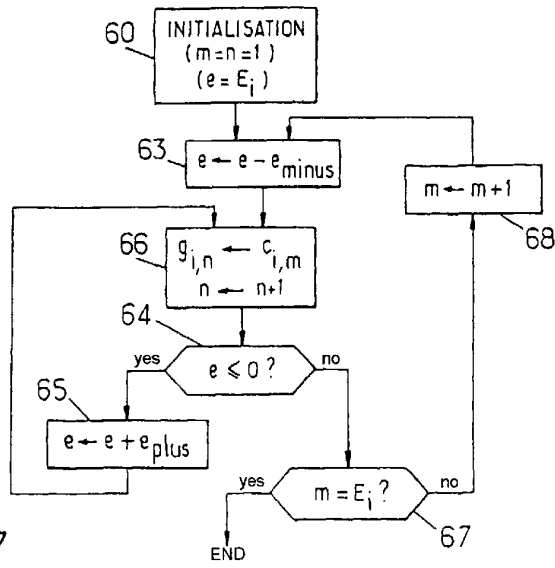

FIG. 7

FIG. 8

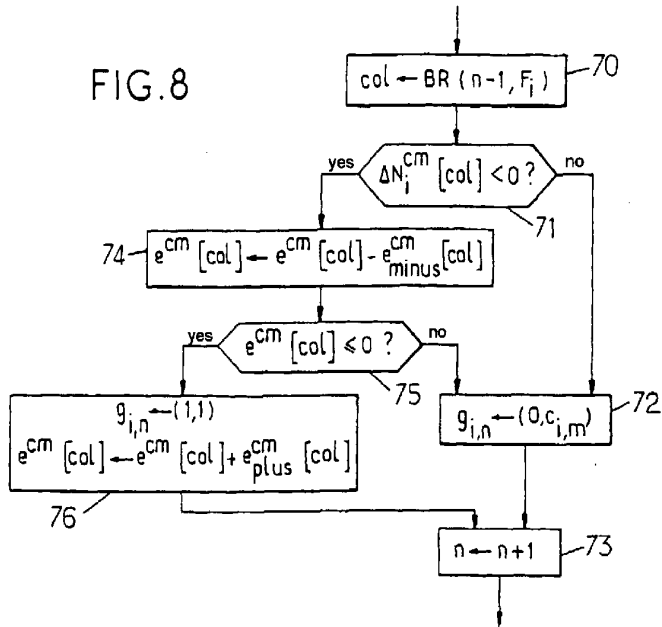

FIG. 9

