

1,298,289.

C. BYRD.
REDUCING MILL.
APPLICATION FILED JUNE 19, 1918.

Patented Mar. 25, 1919.
3 SHEETS—SHEET 1.

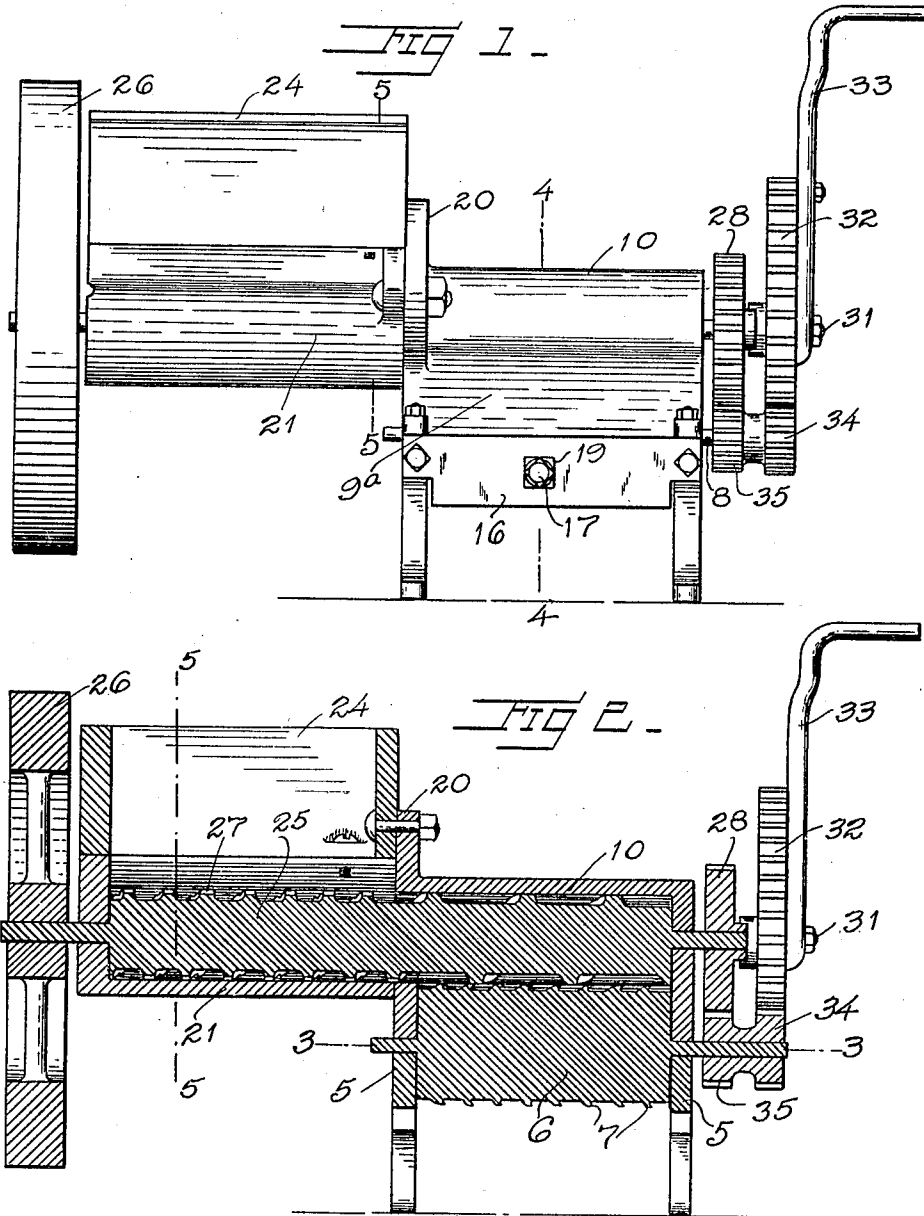

Inventor

Clarence Byrd

By Watson E. Coleman
Attorney

1,298,289.

C. BYRD.
REDUCING MILL.
APPLICATION FILED JUNE 19, 1918.

Patented Mar. 25, 1919.
3 SHEETS—SHEET 2.

FIG 3 -

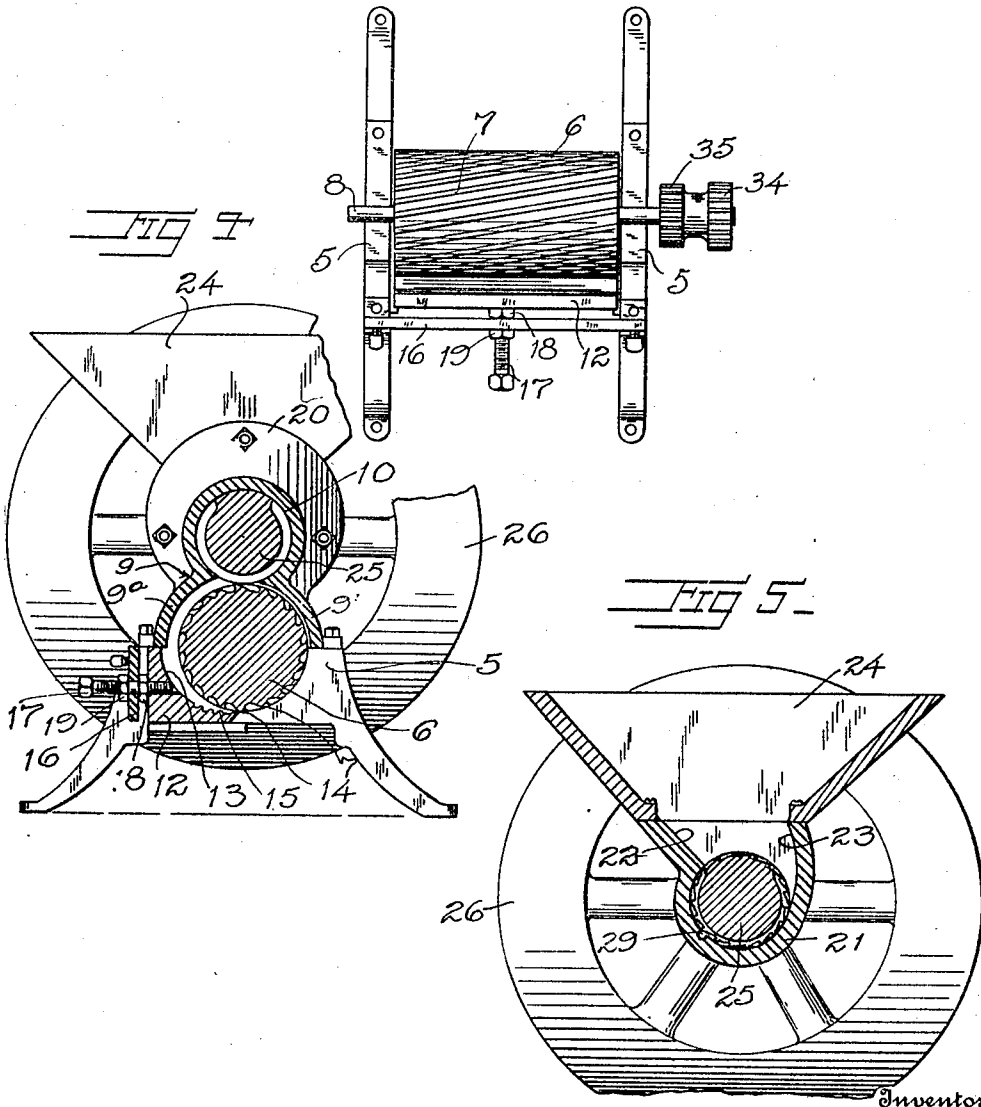

Inventor
Clarence Byrd

By *Watson E. Coleman*
Attorney

1,298,289.

C. BYRD.
REDUCING MILL.
APPLICATION FILED JUNE 19, 1918.

Patented Mar. 25, 1919.
3 SHEETS—SHEET 3.

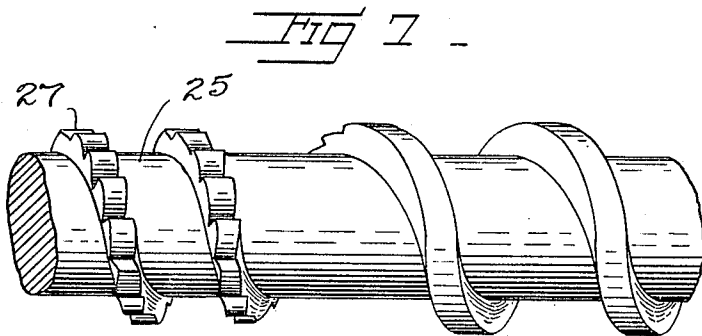
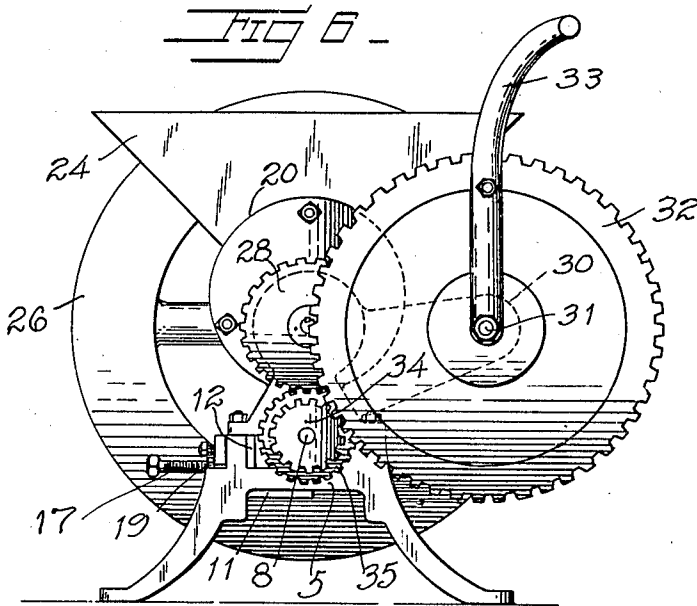

Inventor
Clarence Byrd

By Watson E. Coleman
Attorney

UNITED STATES PATENT OFFICE.

CLARENCE BYRD, OF OPP, ALABAMA.

REDUCING-MILL.

1,298,289.

Specification of Letters Patent. Patented Mar. 25, 1919.

Application filed June 19, 1918. Serial No. 240,752.

To all whom it may concern:

Be it known that I, CLARENCE BYRD, a citizen of the United States, residing at Opp, in the county of Covington and State of Alabama, have invented certain new and useful Improvements in Reducing-Mills, of which the following is a specification, reference being had to the accompanying drawings.

This invention relates to an improved reducing mill, and has for its primary object to provide a mill which is particularly designed for reducing or macerating products to be used as stock feed, which consists of relatively few parts and may be manufactured and sold to the stock raiser at nominal cost.

It is another object of my invention to provide a reducing mill embodying a rotary cutter, and means for initially breaking up the feed and evenly distributing the same longitudinally over and upon the rotary cutter.

And it is another important object of the invention to provide a device for the above purpose which will occupy relatively small space and be of maximum capacity. The mill being operable either manually or by means of a motor or other suitable power.

With the above and other objects in view, the invention consists in the improved construction, combination and relative arrangement of the several parts as will be hereinafter more fully described, subsequently claimed and illustrated in the drawings in which similar reference characters designate corresponding parts throughout the several views, and wherein:—

Figure 1 is a side elevation of a reducing mill constructed in accordance with the preferred embodiment of my invention;

Fig. 2 is a longitudinal section;

Fig. 3 is a horizontal section taken on the line 3—3 of Fig. 2;

Fig. 4 is a section taken on the line 4—4 of Fig. 1;

Fig. 5 is a section taken on the line 5—5 of Fig. 2;

Fig. 6 is an end elevation; and

Fig. 7 is a fragmentary perspective view of the feed worm.

In the Southern States the velvet bean is extensively used as a stock food. The stock raiser is not possessed of the facilities necessary for reducing or macerating the beans,

and the cost to the farmer or stock raiser of having the beans milled or reduced to suitable condition for stock feed is \$4 to \$5 per ton. It is, therefore, the primary object of the present invention to provide a reducing or macerating mill, by means of which the individual farmer at relatively small cost can reduce the beans into the desired comminuted condition and render the same available for stock feeding purposes.

With the above end in view, I have devised my improved reducing mill which in the illustrated embodiment thereof includes spaced bearing supports 5 of suitable construction, which may be bolted or otherwise anchored to a platform or base. Between these supports, a cylindrical cutter 6 is disposed, said cutter having spaced spirally arranged continuous cutting teeth 7 formed upon its periphery. The cutter shaft 8 is journaled at its opposite ends upon the bearing supports 5, and a housing 9 fixed upon said supports extends over the cylindrical cutter. This housing is centrally formed with a cylindrical shell 10 opening at its lower side into the housing immediately above the spiral cutter 6. One side wall 9' of the housing 9 is disposed in close contiguous relation to the spiral blades or teeth 7 of the cutter, while the opposite side wall 9^a of the housing is curved on a relatively wide arc and has its inner face spaced an appreciable distance from the periphery of the cutter. To the bearing supports 5, and below the side wall 9^a of the housing, the supporting and guide plates 11 are fixed. Upon these plates, the transversely adjustable member 12 is arranged, said member extending in parallel relation to the axis of the cylindrical cutter 6. The inner face of this member 12 is concaved as at 13 in eccentric relation to the cutter 6, said member having an inner longitudinally extending knife edge, shown at 14, disposed in a plane in tangential relation to the lower side of the cutting cylinder. The concave face 13 adjacent to said knife edge is grooved or corrugated, as shown at 15, for a purpose which will be presently explained.

A longitudinally extending bar 16 is fixed at its ends to the bearing supports 5. An adjusting screw or bolt 17 is centrally mounted in this bar and has threaded engagement in the member 12. Nuts 18 and 19 are threaded upon the bolt and are adapted to

be engaged against the opposite sides of the bearing 16 to retain the member 12 in its adjusted position relative to the cylindrical cutter 6.

5 Upon one end of the shell 10, the flange 20 is formed, and to this flange the feeding trough 21 is securely bolted at one of its ends. The upper portion of one side wall of said trough is obliquely inclined in an
10 outward direction, as at 22, while the opposite side wall of the trough extends upwardly in a wide curve or arc, as shown at 23. 24 designates the feed hopper, which is suitably mounted and secured upon the walls of the
15 trough 21.

A feed worm 25 is rotatably mounted in the trough 21, one end of said worm being journaled in the outer end wall of the trough and having a balance or fly wheel 26 fixed
20 thereon. The spiral worm blade is notched or toothed, as indicated at 27. This worm also extends through the shell 10 and to the other end thereof, exteriorly of the shell, a gear 28 is fixed. In the inner surface of the
25 wall of the trough 21 on the opposite side of its longitudinal axis with respect to the wall 23 of said trough, a longitudinally extending groove or channel 29 is formed. As the beans are fed by gravity from the hopper 24 into the trough, they move downwardly between the toothed worm and the wall 23 and are carried by the worm teeth
30 downwardly into the trough and into the groove or channel 29. Thus, in the rotation of the worm, the beans will be broken up into coarse particles. The broken beans are then conveyed by the worm into the shell 10 and evenly distributed over and upon the revolving cylindrical cutter 6. This cutter carries the material downwardly through
40 the space between the cutter and the housing wall 9 and delivers the same upon the concave face 13 of the member 12, over which it gravitates downwardly upon the corrugations 15. These corrugations serve to check the flow of the material and counteract the tendency of the draft around the cutter 6 and between the same and the member 12 to draw and pack the material between the
50 concave face 13 and the cutter and thus choke up the machine so that the cutter would not operate to effectively cut or shred the material. By providing such means for controlling the delivery of the material to the spiral blades or teeth of the revolving
55 cutter, said teeth act to shave or shred the beans or feed material and reduce it to a finely comminuted condition. This material is delivered below the cutter into a suitable
60 receptacle.

In the illustrated embodiment of my invention, I have disclosed means for manually operating the mill. To this end, an arm or bracket 30 is formed upon one end of the
65 housing 9 and upon a stud bolt or shaft 31

fixed in this arm a gear wheel 32 is rotatably mounted. A suitable operating crank or handle 33 is attached to this gear wheel. The gear wheel 32 meshes with a gear 34 fixed upon one end of the cutter shaft 8, 70 and a second gear 35 fixed upon said shaft has meshing engagement with the gear 28 on the end of the feed worm 25. It will thus be seen that when the gear wheel 32 is turned by means of the crank, rotation is im- 75 parted to the feed worm and the cutting cylinder in relatively opposite directions. By the proper adjustment of the member 12, toward or from the cutting cylinder 6, the material may be cut to any desired degree 80 of fineness. In lieu of the manual means for operating the mill above referred to, the machine may obviously be operated by means of a motor or other suitable power means. 85

From the foregoing description, taken in connection with the accompanying drawing, the construction, manner of operation and several advantages of my invention will be clearly and fully understood. The mill 90 can be constructed in various sizes and the spiral teeth or cutting blades on the cylinder 6 may have any desired pitch so that the cut will be longer or shorter as preferred. The machine is likewise susceptible of many 95 minor modifications in the form, construction and relative arrangement of the several parts, and it is, therefore, to be understood that while I have herein shown and described the preferred embodiment of the de- 100 vice, I reserve the privilege of adopting all such legitimate changes as may be fairly embodied within the spirit and scope of the invention as claimed.

I claim:—

1. In a reducing mill, a revoluble cutter, a rectilinearly movable member for directing the material to the cutter and having a face opposed to the cutter and concaved in eccentric relation thereto, the major portion 110 of said concave face being unbroken and said member having a series of grooves formed in said concave face adjacent to the cutter, and means for adjustably positioning said member relative to the cutter. 115

2. In a reducing mill, a revoluble cutter, a rectilinearly shiftable member for directing the material to the cutter, said member having a knife edge disposed in tangential relation to the cutter and being provided 120 in the face thereof which is opposed to the cutter and contiguous to the knife edge with a series of longitudinally extending grooves, and means for adjusting said member toward or from the cutter. 125

3. In a reducing mill, a revoluble cutter, a housing extending over the cutter and having a shell communicating with the housing above said cutter, a feeding trough fixed to one end of said shell, a rotatable worm ex- 130

tending through the trough and said shell to convey the material from the trough into the shell and equally distribute the same longitudinally upon the cutter, the wall of said
5 trough at one side of the axis of the feed worm having a longitudinally extending channel therein, and said worm being toothed to cooperate with said channel and break up the material prior to its delivery to the cutter. 10

In testimony whereof I hereunto affix my signature in the presence of two witnesses.
CLARENCE BYRD.

Witnesses:

HUGHIE F. BENTON,
R. S. JEFFCOAT.

Copies of this patent may be obtained for five cents each, by addressing the "Commissioner of Patents, Washington, D. C."