

⑫

EUROPEAN PATENT APPLICATION

⑳ Application number: 88303351.6

⑤① Int. Cl.4: **E 06 B 1/06**
E 04 D 13/03, G 01 C 9/12

㉒ Date of filing: 14.04.88

③① Priority: 15.04.87 DK 1975/87

④③ Date of publication of application:
19.10.88 Bulletin 88/42

⑧④ Designated Contracting States:
AT BE CH DE ES FR GB IT LI NL SE

⑦① Applicant: **V KANN RASMUSSEN INDUSTRI A/S**
No. 10 Tobaksvejen
DK-2860 Soborg (DK)

⑦② Inventor: **Morck, Ole Phaff**
12 Harlosevej
DK-3320 Skaevinge (DK)

Bergman, Dennis
20 Arent Hansensvej Smlidstrup
DK-3250 Gilleleje (DK)

⑦④ Representative: **Ford, Michael Frederick et al**
MEWBURN ELLIS & CO. 2/3 Cursitor Street
London EC4A 1BQ (GB)

The title of the invention has been amended (Guidelines for Examination in the EPO, A-III, 7.3).

⑤④ **Window frame panel kit and an auxiliary device for producing a window frame.**

⑤⑦ A frame panel kit for a window in an inclined roof comprises two plate members (10) accommodating side plates (2, 3) for arrangement in vertical planes perpendicular to the roof surface and a top member (4) and a bottom member (5) which in the installed position are substantially horizontal and vertical. Two fan-shaped sets (16, 17) of line markings (21a to 27a, 21b to 27b) are provided on the back of each of said plate members (10) for use in arranging the top member and the bottom member with respect to an actual roof inclination, said sets of line markings covering an angular range from 30° to 60° with the outer edge (10) of the plate member, each line marking (27a, ..) in one set (16) being perpendicular to a marking (21b, ..) in the second set (17). The first and second, resp., of two additional plate members (19, 20) are used as top member (4) and bottom member (5), said plate members being individually bent or curved into an angular shape with angles (U, V) of approximately 30° and 45°, resp., between the mainly plane parts (32, 34; 33,35) of the plate members. All plate members (10) have ready-made outer edges (11, 28, 29) to be assembled with grooves in the installed window main frame and are width-adaptable to the thickness of the sloping wall by cutting-off from their internal edges. Predetermined line markings in either set are intended for the first and second,

resp., of said additional plate members (19, 20).

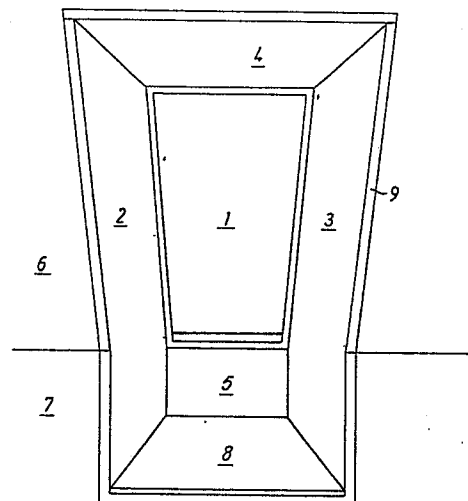

FIG. 1

Description**A Window Frame Panel Kit.**

This invention relates to a frame panel kit for a window installed in an inclined roof, comprising plate members accommodating side plates for arrangement in vertical planes perpendicular to the roof surface and a top and a bottom member to be assembled with said plate members with their end edges abutting the opposing front surfaces thereof in such positions that in the installed position the top member and the bottom member are substantially horizontal and vertical, two fan-shaped sets of preferably angle-equidistant line markings being provided on the back of each of said plate members for use when arranging the top member and the bottom member, each line marking in the first set forming together with a line marking in the other set a pair of line markings perpendicular to each other.

In order to avoid entirely manual handycraft production of frame panels in connection with the installation of windows in inclined roof surfaces a frame panel is known from EP-A-0141567 that may be supplied with side plates, top and bottom members in a building kit that can be easily assembled in situ and can be quickly mounted by allowing for adaptation to the actual roof thickness and inclination. It is prescribed for this known structure that adapting of the plate members of the kit in the transverse direction to an actual thickness of a sloping wall is to be performed by cutting-off from the outer edges of the plate members, which has the disadvantage of impeding a correct adaptation of the panel to the window main frame, e.g. by engagement with grooves therein. In order that said cutting-off may be effected, the end edges of the plate members constituted the side members are, on one hand, provided with a part close to the outer edge perpendicular to the window main frame and, on the other hand, with a bevelled part facing the inner edge and forming such an angle with the parallel outer and inner edges of the side member that the latter part of the end edge extends subsequently horizontally and substantially vertically at the upper and lower end of the side member, respectively. With a view to make a given side member applicable for more than one roof inclination it has further been suggested that the bevelled parts perpendicular to each other of the end edges of a side member form different angles, e.g. 40° and 50° or 30° and 60°, with the outer edge and inner edge of said side member. Said design does not, however, provide for covering a greater range of roof inclinations, e.g. from 30° to 60° with one and the same shape of the side members.

The shape of the side members with end edges that are ready-made with bevelled parts extending at said angles entails, moreover, that undesired large deviations from the desired location of the top and bottom members in a horizontal and a vertical plane, resp., must be accepted for roof inclinations in the range between the angular magnitudes of the bevelled parts of the end edges.

The latter disadvantages have been eliminated by a design of the type mentioned above known from DE-U-78 09 898 according to which a comparatively correct positioning of the top and the bottom members may be obtained by means of said line markings on the side members. In this known design the kit is supplied with side, top and bottom members in ready cut sizes also in the transverse direction and it is prescribed that an intermediary frame must be inserted between the frame panel assembly itself and the window frame, probably with the purpose of compensating for variations of the thickness of a sloping wall. In order to obtain an adaptation of the width of the horizontally placed top member in dependence on an actual roof inclination a bipartite design of the top member is further prescribed with a section of constant width positioned closest to the window main frame and an internal part of varying width dependent on the roof inclination and assembled therewith by means of a ribgroove connection so that said internal parts must be supplied in varying sizes to be adapted to different roof inclinations, and intermediary frames fitted to varying thicknesses of sloping walls must be supplied as well.

It is the object of the invention to provide a frame panel kit of the type mentioned by which it is possible, as distinct from said prior designs, by one and the same kit, i.e. without changing the size and shape of the plate members forming part of the kit, to build up frame panels suited for any arbitrary roof inclination and any thickness of sloping walls within a considerable range, and a mainly horizontal top member and a mainly vertical bottom member are at the same time always obtained together with a good adaptation to the window main frame without making use of any intermediary frame.

This is obtained according to the invention in that first and second additional plate members are used as top member and bottom member, each of said additional plate members being bent or curved into an angular shape along a bending line positioned at a short distance from the outer edge of the member and having angles of approximately 30° and 45°, resp., between the mainly plane parts of the plate members located on either side of the folding line, the plate members accommodating the side plates as well as said additional plate members having ready-made outer edges to be assembled with grooves in the installed window main frame and being width-adaptable to the thickness of the sloping wall by cutting from their internal edges, each set of said line marking on each of the plate members accommodating the side plates covering an angular range from 30° to 60° with the outer edge of the plate member, and predetermined line markings in either set being intended for the first and the second, resp., of said additional plate members.

A building kit manufactured in this manner and comprising four plate members which for a given window are supplied with determined sizes and shapes provides for giving the frame panel a shape fitting in with an arbitrary roof inclination within a range, e.g., from approximately 27.5° to approximately 62.5° and with a maximum deviation from the ideal horizontal and vertical orientation of the top and bottom members of $\pm 2.5^\circ$.

A suitable adaptation to an actual thickness of a sloping wall may at the same time be obtained and thus also a compensation for minor variations thereof, e.g. between the two vertical lateral surfaces of the light area. In view of the fact that the kit is supplied with ready-made outer edges of the plate member, e.g. fitting in with the grooves in the window main frame, a safe and tight connection with the window main frame is obtained as well.

In respect of the fact that a determined roof inclination always requires one of the two additional plate members to be used as top member and the other as bottom member the entire above mentioned range can be covered without any need of interchanging the side members or turning them upside down as prescribed in the above mentioned European patent application. In a given kit the plate members accommodating the side plates will thus be predetermined for use in the left or right side of the light area and must always be mounted with the same orientation in the upward or downward direction.

Thereby the particular advantage is obtained that the kit may be formed to fit in with a larger opening towards the room compared to the window light area proper, thereby providing for instance a niche within a vertical wall below the window.

A preferred embodiment of the frame panel kit according to the invention suitable for that purpose is characterized in that the plate members accommodating the side plates are trapezoidal with parallel top and bottom edges perpendicular to said outer edge, the top edge having a length corresponding to a predetermined maximum thickness of a sloping wall and a minimum roof inclination, while the bottom edge has such an increased length in comparison with the top edge and the plate member has such a height that besides accommodating the side plate necessary for a light area positioned entirely in the inclined roof surfaces, said plate member also accommodates a plate part forming a side wall of a niche with a substantially horizontal bottom plate in vertical wall positioned below the window.

The invention further relates to an auxiliary device to be used when assembling the frame panel from the kit. According to the invention and auxiliary device includes a disc-shaped member having a rectilinear edge to be held against the window while holding the member in a substantially vertical plane, a plumbline secured at a short distance from said edge, a set of fan-shaped line markings having a numbering corresponding to a numbering of either set of line markings on said plate members and in connection with the set of line markings a bipartite circular marking for selection of said additional plate members as top member and bottom member, resp.

By this very simple auxiliary device which without any noticeable price increase may be supplied to gether with the kit, user is capable of deciding in situ, by simply measuring without making use of any separate measuring instruments which line marking on the side plates in either set to use and which of the additional plate members to use as top member and bottom member, resp.

The invention will now be explained in detail with reference to the schematical drawings, in which

Fig. 1 is an example of a frame panel with an underlying window niche designed by means of the kit according to the invention,

Figs 2, 3 and 4 illustrate embodiments of the plate members forming part of the kit.

Fig. 5 illustrates an embodiment of an auxiliary device to be used when assembling the frame panel,

Figs 6 and 7 illustrate a vertical and a horizontal sectional view, resp., of an installed frame panel, and

Fig. 8 illustrates the plate member shown in Fig. 2 with marked cutting lines.

In the example illustrated in Fig. 1 of the completed frame panel assembled from the kit according to the invention the frame panel consists of two side members 2 and 3 positioned in parallel vertical planes aligned with the vertical main frame members of the window 1 and a substantially horizontal top member 4 and a substantially vertical bottom member 5.

At their internal edges facing the room the side members 2 and 3 joint the internal sloping wall 6 and a vertical cupboard wall 7 positioned therebeneath, in which the frame panel in the illustrated embodiment forms a window niche with a substantially horizontal bottom plate 8 between the bottom member 5 and the vertical wall 7. The edges of plate members 2, 3, 4 and 8 and the spaces therebetween and the adjacent wall portions may, as illustrated, be covered by cappings 9.

Side members 2 and 3 may be shaped from a plate member 10 as illustrated in Fig. 2. Said member is produced, as will be described in the following, with a ready-made outer edge 11 to be mounted on the window main frame, e.g. in engagement with a groove in the vertical main frame member. The top edge 12 and the bottom edge 13 are parallel and perpendicular to the outer edge, and the plate member intended for a determined window size has a height that is so much higher than the window height corresponding to the distance between line markings 14 and 15 parallel to edges 12 and 13 that plate member 10 by installation at an arbitrary roof inclination will overlap the end edges of the top member and bottom member of the panel when said two members are positioned correctly in a horizontal and a vertical position, resp., i.e. at an angle with outer edge 11 equal to and complementary with respect to the roof inclination, respectively.

In the illustrated example plate member 10 is trapezoidal with increasing width in the direction from top edge 12 towards bottom edge 13 and the member has such a magnitude that its lower part beyond the line marking 15 may accommodate the part of the side member which in the embodiment in Fig. 1 delimits the niche located beneath the window.

Plate member 10 illustrated in Fig. 2 and accommodating side member 2 to be mounted on the left side of the lining is provided on the reverse side illustrated in the figure with two sets of fan-shaped line markings 16 and 17, resp., outside line markings 14 and 15. In the illustrated example either of said sets comprises seven line markings 21a to 27a and 21b to 27b, resp., that are mainly angle-equidistant and which altogether covers

an angular range from 30° to 60° in relation to outer edge 11, in the illustrated example corresponding to an angular separation of 5°. The line markings are made so that for a determined roof inclination one line marking is used from either set, e.g., 21a and 21b, for a roof inclination of 30°, said markings being at right angles to each other.

5 The line markings of sets 16 and 17 may incidentally to be used to adapt plate member 10 by cutting to the orientation determined by the roof inclination of the top and bottom edges of side member 2, but they are preferably provided with punched markings 18, e.g. in the form of blind holes of comparatively low depth reckoned from the back of the member and placed along the line markings so as to correspond to pre-drilled screw holes at the end edges of the additional plate members that will be dealt with in the following and which
10 accommodate top member 5 and bottom member 5 of the frame panel.

As illustrated in Figs 3 and 4 said two additional plate members 19 and 20 are likewise provided with ready-made outer edges 28 and 29 to be fitted into the horizontal main frame members of the window main frame and both of them are angularly bent or curved along a bending line 30 and 31, resp., provided in parallel with and at a comparatively short distance from the outer edge and which separates a comparatively narrow
15 outer part 32 and 33 abutting the window main frame and being almost perpendicular thereto and a comparatively wide inner part 34 and 35, resp., facing the actual attic and which in the assembled frame panel must be placed mainly vertically or mainly horizontally, as already mentioned.

In accordance with the invention the bending angles \underline{u} and \underline{v} of plate members 19 and 20 illustrated in Figs 2 and 3 are different, viz. about 45° and about, 30°, so that said two members are used as top member 4 and
20 bottom member 5, resp., dependent on the actual roof inclination. From the recognition that it is of minor importance as regards the appearance of the frame panel whether outer parts 32 and 33 of plate members 19 and 20 are exactly perpendicular to the horizontal window main frame members or form a smaller angle therewith, it may thus be obtained that top member 4 and bottom member 5 of the frame panel as regards any
25 roof inclination within the range determined by line marking sets 16 and 17 only present a deviation from the intended horizontal and vertical positioning that is quite indifferent to the appearance, viz. corresponding at a maximum to half the angular distance between the individual line markings, in the illustrated example $\pm 2.5^\circ$.

In order to measure the roof inclination and thus select the actual line markings of marking sets 16 and 17 and to determine the application of plate members 19 and 20 as a top member 4 and bottom member 5, resp.,
30 an auxiliary device may be used according to the invention which as illustrated in Fig. 5 may consist of a single disc member 36 having a rectilinear outer edge 37 to be held against a window 38 installed in the roof surface, the member 36 being held in a subsequently vertical plane.

A plumb-line 39 is secured to disc member 36 in fixing point 38 at short distance from the outer edge 37 and below the fixing point 38 member 36 is provided with a fan-shaped set 40 of line markings 21c to 27c
35 corresponding to the markings of sets 16 and 17 on the back of each plate member 10, i.e. at the same angular separation for instance of 5° and covering a range from 30° to 60° in relation to edge 37.

In connection, with, for instance just opposite line marking set 40, disc member 36 is, moreover, provided with a bipartite marking 41 shaped as a circular arc to be used when selecting plate members 19 and 20 as the
40 top member and bottom member, resp.

For a given individual roof inclination defined as the angle of the roof surface with the horizontal plane in the
45 range from 27.5° to 62.5°, the following Table will show the selection of line markings and the application of plate members 19 and 20 as top member 4 and bottom member 5:

	<u>Roof Inclination</u>	<u>Line Marking</u>	<u>Top Member</u>	<u>Bottom Member</u>
45	27.5 to 32.5	21 a-b	19	20
	32.6 to 37.5	22 a-b	19	20
50	37.6 to 42.5	23 a-b	19	20
	42.6 to 47.5	24 a-b	20 (19)	19 (20)
	47.6 to 52.5	25 a-b	20	19
55	52.6 to 57.5	26 a-b	20	19
	57.6 to 62.5	27 a-b	20	19

60 It will appear from the Table that line markings 21a to 23a of the upper line marking set 16 on plate members 10 are to be used solely in association with plate member 19 while line markings 24a to 27a are to be used solely in association with plate member 20. Inversely, line markings 21b to 23b of the bottom line marking set 17 are to be used in association with plate member 20 and line markings 24b to 27b are to be used solely in
65 association with plate member 19. In the illustrated case with an odd number of line markings in either set it will be principally indifferent, as regards the middle angular sector of the range corresponding to line markings 24,

whether use is made of one instruction or the other with respect to the application of plate members 19 and 20, but with view to obtaining a correct correspondence between the markings along said line marking provided for the boring of holes and the pre-drilled screw holes at the end of the plate member, a definite application of plate members 19 and 20 should in practice be prescribed and the same applies to line markings 24.

The fact that predetermined line markings in either set are thus meant to be used for the first and the second of plate members 19 and 20, resp., considerably facilitates in practice the correct positioning of hole markings 18 which as mentioned must correspond exactly to the pre-drilled screw holes 41 at the end edge of plate members 19 and 20 and which, moreover, must be positioned so accurately that outer edges 28 and 29 of said plate members fit exactly in with grooves provided for that purpose in the horizontal main frame members independent of the application of members 19 and 20 as top member of bottom member.

Figs 6 and 7 are sectional views of the frame panel when mounted. As illustrated in Fig. 6, grooves 44 and 45, resp., are provided on the horizontal main frame members 42 and 43 of window 38, said grooves being adapted to receive outer parts 32 and 33 of plate members 19 and 20 serving as top member 4 and bottom member 5, resp., in such a manner that the angular position of outer parts 32 and 33 may vary in relation to a plane position perpendicular to the window main frame.

As illustrated in Fig. 7 grooves 28 and 49 provided in the side members of the main frame and are adapted to receive the ready-made outer edges 11 of plate members 10 used as side members 2 and 3.

The cutting of plate members 10 will be explained in the following with reference to Figs 6 and 8.

Following the determination of an actual roof inclination by means of the auxiliary device shaped as disc members 36, in the present case e.g. an inclination of about 40° corresponding to marking line 23c on disc member 36, cutting lines 50 and 51 are drawn parallel to marking lines 23a and 23b on plate member 10, but at a distance therefrom corresponding to the plate thickness.

The distance T determining the width of the side member is then measured from the window main frame to sloping wall 6 at right angles to the plane of the window main frame, as illustrated in Fig. 6. Said measuring is effected preferably both at the uppermost horizontal main frame member 42 and opposite the corner between sloping wall 6 and vertical wall 7. The dimensions T are marked out on plate member 10 from its outer edge 11 and perpendicular thereto, following which the vertical cutting line 52 may be drawn between line markings 14 and 15.

The height H is subsequently measured as the height distance from the projection of the lower edge of groove 44 in the upper horizontal main frame member 42 on to sloping wall 6 to the corner between sloping wall 65 and vertical wall 7 and said height dimension H is marked out on plate member 10 downwards from line marking 14 along cutting line 52 on to point 53.

The desired depth B of the niche beneath the frame panel is then determined as the distance from the corner between sloping wall 6 and vertical wall 7 to the desired positioning of bottom member 8. The resulting dimension is then marked out on plate member 10 reckoned from point 53 along a cutting line 54 parallel to cutting line 51 that is parallel to line marking 23b, following which cutting line 55 is drawn at right angles to lines 51 and 54.

It is pointed out that the measuring and the marking-out steps have been explained here only very roughly. In practice it is generally necessary to make corrections of the thickness of plate and so on. However, such corrections may be pre-calculated and then specified in detailed directions for use supplied with the kit.

After said two side members 2 and 3 have been adapted by cutting and the holes therein have been drilled by use of punched markings 18 in actual line markings, the width of plate members 19 and 20 are adapted by cutting at a distance from inner edges 55 and 56, resp., located opposite outer edges 28 and 29, following which side members 2 and 3 may be screwed together with top member 4 and bottom member 5 - supplied in correct dimensions of length and, as mentioned, with pre-drilled screw holes as shown by 57 - into a substantially rectangular box that is subsequently positioned correctly in relation to the window main frame and sloping wall 6 and vertical wall 7 and secured thereto in a manner not shown. Bottom member 8 that may be prepared in situ or supplied as a separate part is finally mounted. In order to obtain access to the space behind vertical wall 7 bottom member 8 may be appropriately be hinged at the back.

The manufacturing of plate members 10 may be simplified in that each of the fan-shaped line markings is solely constituted by perforation markings 18 provided along a line in the form of punched or blind holes.

Claims

1. A frame panel kit for a window installed in an inclined roof, comprising plate members (10) accommodating side plates (2, 3) for arrangement in vertical planes perpendicular to the roof surface and a top member (4) and a bottom member (5) to be assembled with said plate members (10) with their end edges abutting the opposing front surfaces thereof in such positions that in the installed position the top member (4) and the bottom member (5) are substantially horizontal and vertical, two fan-shaped sets (16, 17) of preferably angle-equidistant line markings (21a to 27a, 21b to 27b) being provided on the back of each of said plate members (10) for use when arranging the top member and the bottom member, each line marking (27a, ..) in one set (16) forming together with a line marking (21b, ..) in the other set (17) a pair

of line markings perpendicular to each other, characterized in that first and second additional plate members (19, 20) are used as top member (4) and bottom member (5), each of said additional plate members being bent or curved into an angular shape along a bending line (30, 31) positioned at a short distance from the outer edge (28, 29) of the member and having angles (U, V) of approximately 30° and 45°, resp., between the mainly plane parts (32, 34; 33, 35) of the plate members located on either side of the bending line, the plate members (10) accommodating the side plates (2, 3) as well as said additional plate members (19, 20) having ready-made outer edges (11, 28, 29) to be assembled with grooves (44, 45, 48, 49) in the installed window main frame and being width-adaptable to the thickness of the sloping wall by cutting from their internal edges, each set (16, 17) of said line markings on each of the plate members (10) accommodating the side plates covering an angular range from 30° to 60° with the outer edge (10) of the plate member, and predetermined line markings in either set being intended for the first and the second, resp., of said additional plate members (19, 20).

2. A frame panel kit as claimed in claim 1, characterized in that said additional plate members (19, 20) are provided with pre-drilled screw holes (57) at their end edges and that markings (18) along each line marking (21a to 27a; 21b to 27b) are provided for the drilling of holes which in said predetermined line markings correspond to said pre-drilled screw holes (57) in the first and the second, resp., of said additional plate members (19, 20).

3. A frame panel kit as claimed in claim 1 or 2, characterized in that the outer edges (28, 29) of said additional plate members (19, 20) and the grooves (44, 45) provided therefor in the horizontal main frame members of the window main frame are made so that the angular position of the part (32, 33) of the top member (4) and the bottom member (5), resp., positioned between the window main frame and said bending line (30, 31) may vary in relation to a position perpendicular to the window main frame.

4. A frame panel kit as claimed in claim 1, 2 or 3, characterized in that the plate members (10) accommodating the side plates (2, 3) are trapezoidal with parallel top and bottom edges (12, 13) perpendicular to said outer edge (11), the top edge (12) having a length corresponding to a predetermined maximum thickness of a sloping wall and a minimum roof inclination, while the bottom edge (13) has such an increased length in comparison with the top edge and the plate member has such a height that besides accommodating the side plate necessary for a light area positioned entirely in the inclined roof surfaces, said plate member also accommodates a plate part forming a side wall of a niche with a substantially horizontal bottom plate (8) in vertical wall (7) positioned below the window.

5. An auxiliary device for use in the preparation of a window frame panel from a frame panel kit as claimed in one of the preceding claims, characterized in that it includes a disc-shaped member (36) having a rectilinear edge (37) to be held against the window while holding the member in a substantially vertical plane, a plumb-line (39') secured at a short distance from said edge (37), a set of fan-shaped line markings (40) having a numbering (21c to 27c) corresponding to a numbering of either set of line markings (16, 17) on said plate members (10) and in connection with the set (40) of line markings a bipartite circular marking (41) for selection of said additional plate members as top member and bottom member, resp.

6. A frame panel kit for a window installed in an inclined roof comprising a pair of side plates (2, 3) for arrangement in vertical planes perpendicular to the roof surface and a top member (4) and a bottom member (5) to be assembled with said plate members (2, 3) with their end edges abutting the confronting faces thereof in such positions that in the installed position the top member (4) and the bottom member (5) are substantially horizontal and vertical, markings (21a to 27a, 21b to 27b) being provided on the back of each of said plate members (2, 3) for use when positioning the top member and the bottom member, characterized in that plate members (19, 20) used as top member (4) and bottom member (5), each have a marginal strip adjacent the outer edge (28, 29) of the member inclined at a respective angle (U, V) to the generally plane remainder of the plate member.

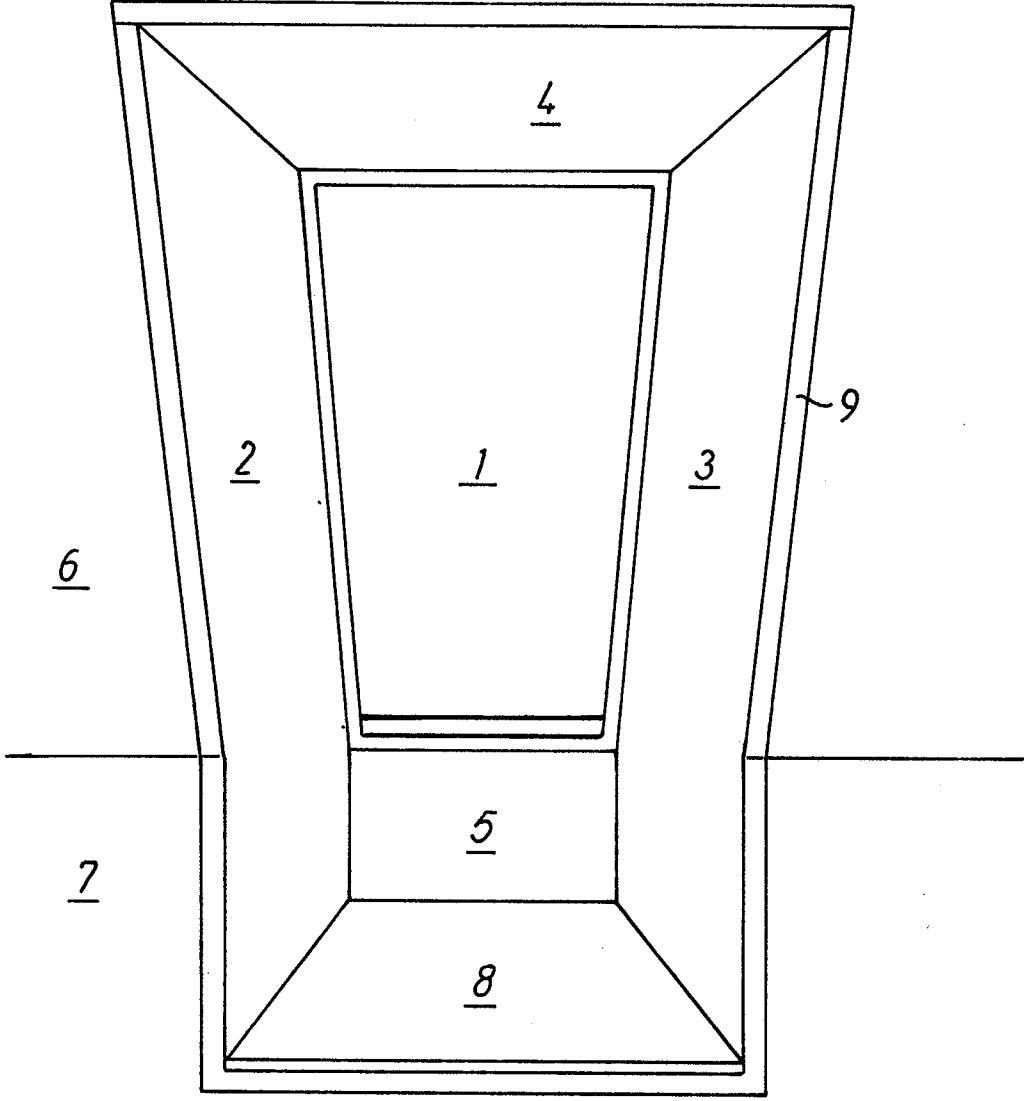

FIG. 1

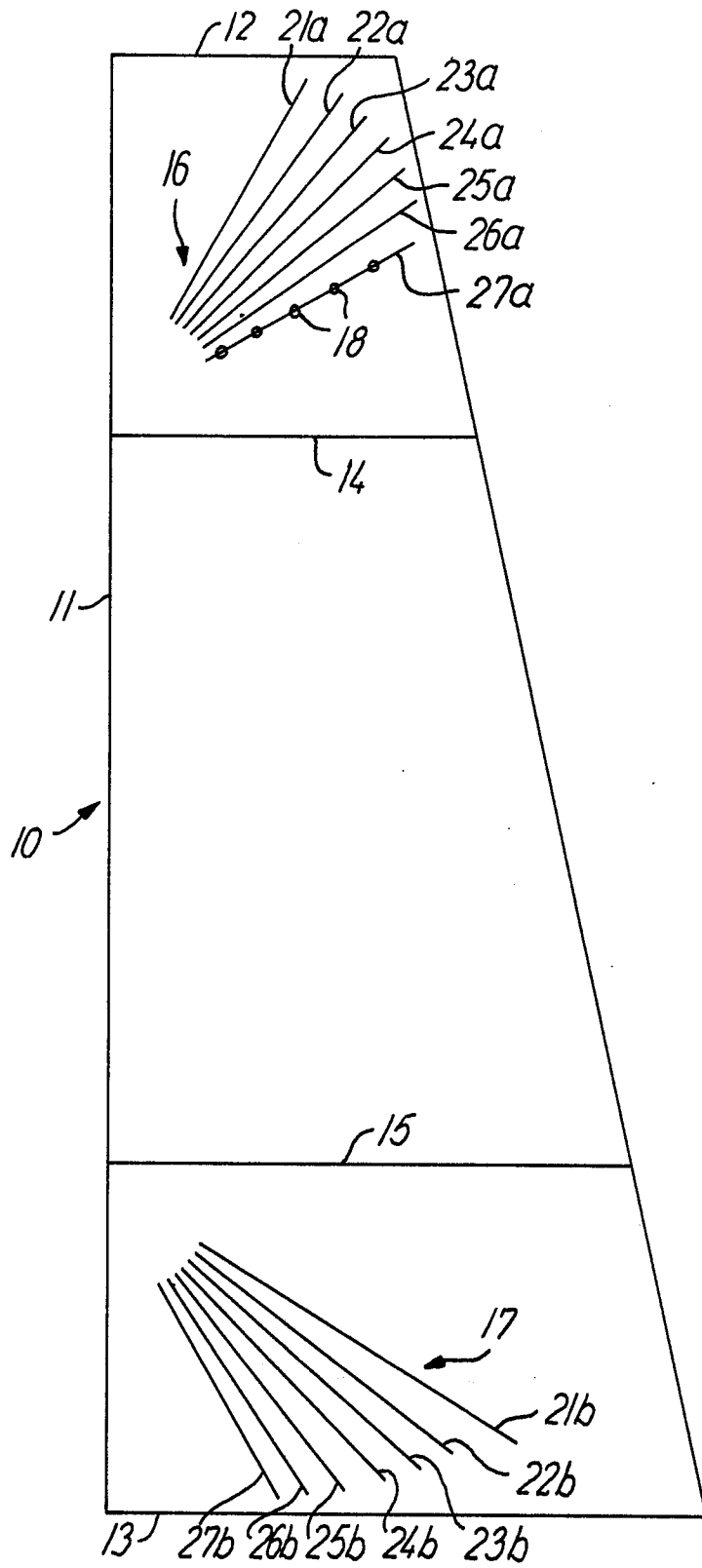
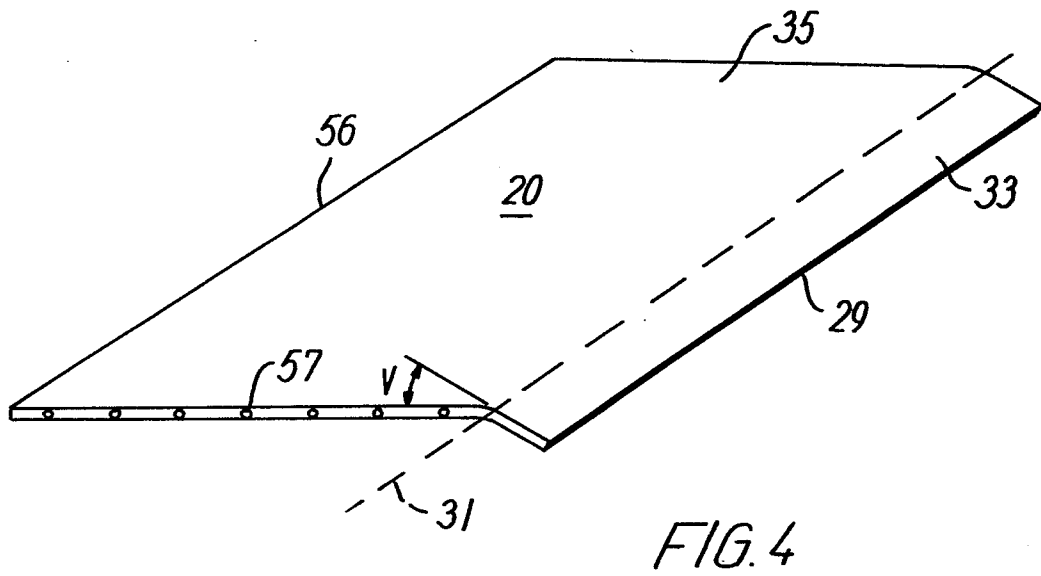
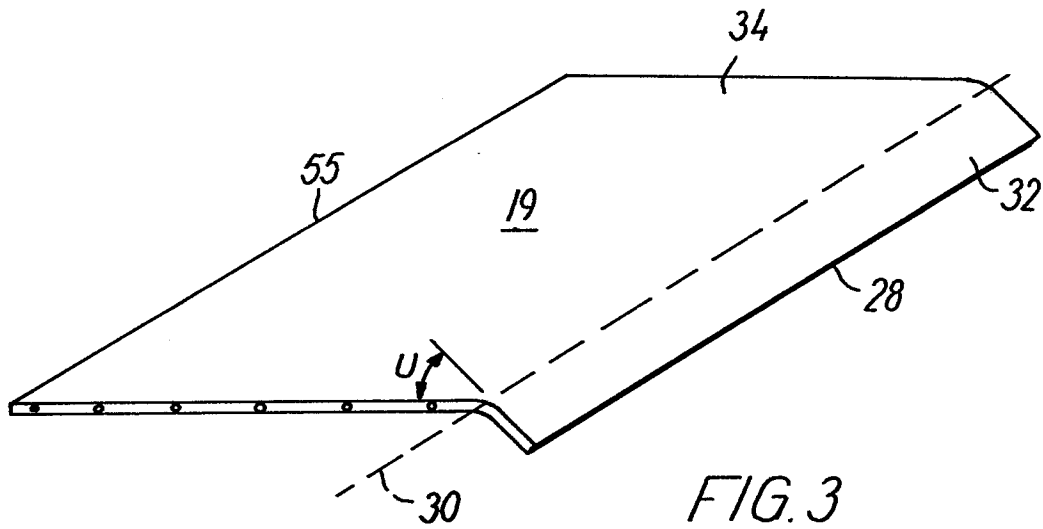
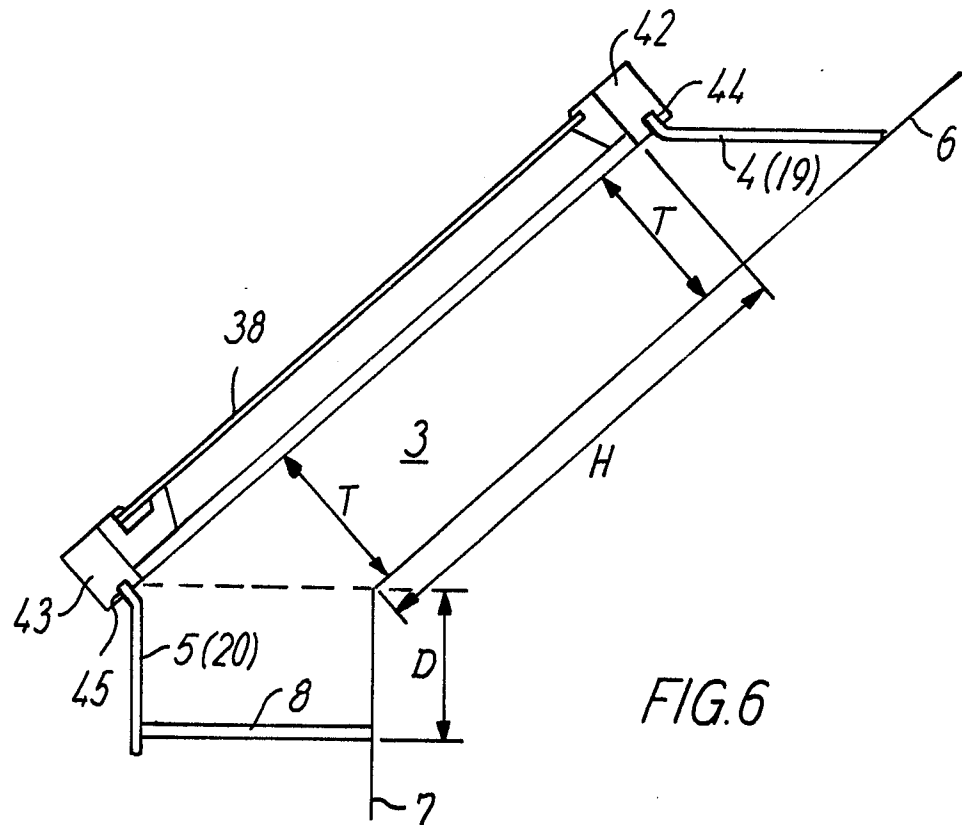
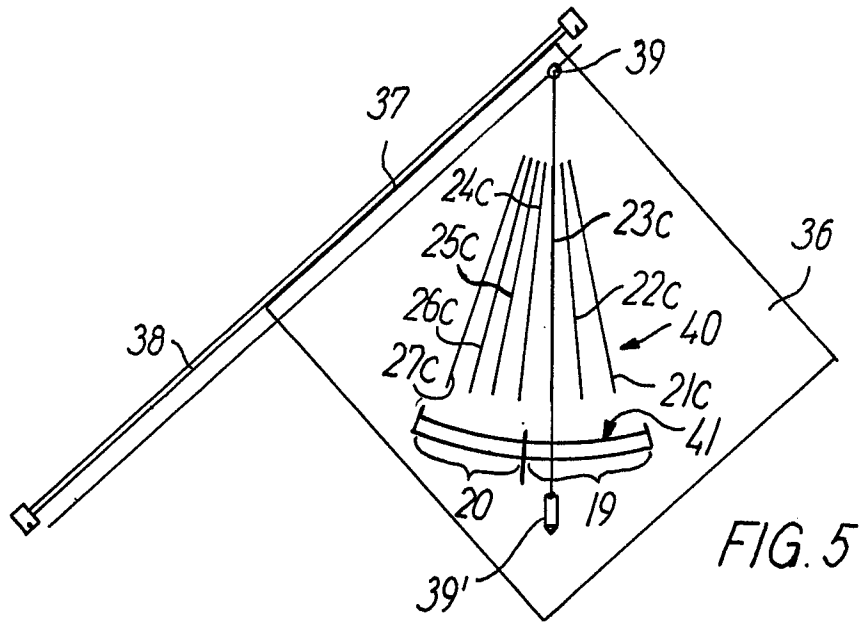

FIG. 2

0287362



0287362



0287362

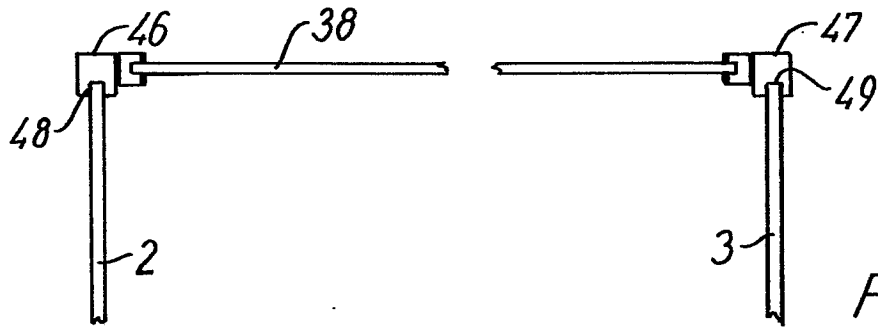

FIG. 7

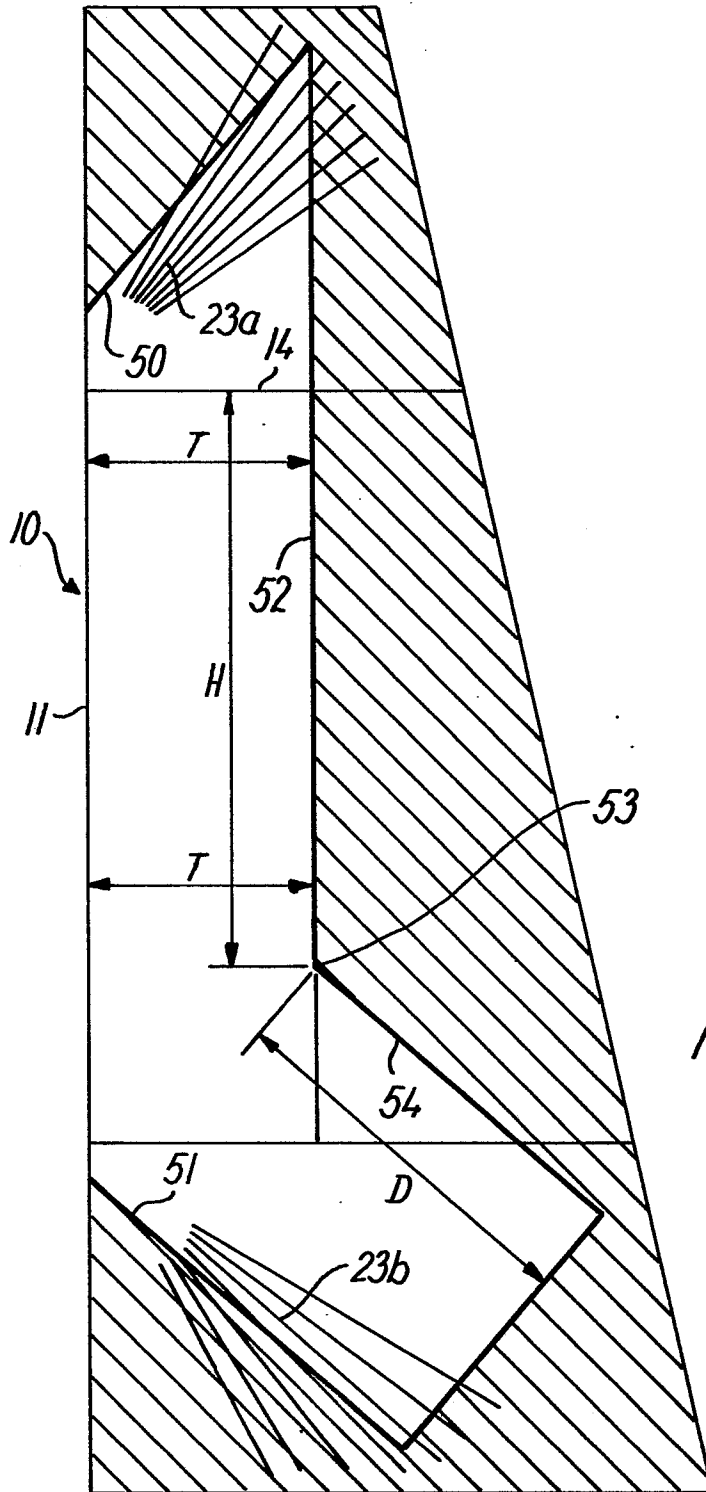

FIG. 8



DOCUMENTS CONSIDERED TO BE RELEVANT			
Category	Citation of document with indication, where appropriate, of relevant passages	Relevant to claim	CLASSIFICATION OF THE APPLICATION (Int. Cl.4)
A	DK-B- 149 655 (V. KANN RASMUSSEN HOLDING A/S) *Page 3, lines 1-28*	1-4, 6	E 06 B 1/06 E 04 D 13/03 G 01 C 9/12

A	US-A-2 724 152 (A.M. MASSANO) *Column 3, lines 14-24*	1-4, 6	

A	US-A-3 363 369 (E.E. MILLER) *Column 3, lines 14-21*	1-4, 6	

A	US-A- 834 765 (J. SECHLER) *Lines 35-72*	5	

A	US-A- 885 076 (A. OLSON) *Lines 28-69*	5	TECHNICAL FIELDS SEARCHED (Int. Cl.4) E 04 B E 04 D E 06 B G 01 C

The present search report has been drawn up for all claims			
Place of search STOCKHOLM		Date of completion of the search 10-06-1988	Examiner JUVONEN V.
CATEGORY OF CITED DOCUMENTS X : particularly relevant if taken alone Y : particularly relevant if combined with another document of the same category A : technological background O : non-written disclosure P : intermediate document T : theory or principle underlying the invention E : earlier patent document, but published on, or after the filing date D : document cited in the application L : document cited for other reasons & : member of the same patent family, corresponding document			