



US 20080115275A1

(19) **United States**
(12) **Patent Application Publication**
Rawls-Meehan

(10) **Pub. No.: US 2008/0115275 A1**
(43) **Pub. Date: May 22, 2008**

(54) **METHODS AND SYSTEMS OF AN ADJUSTABLE BED**

(60) Provisional application No. 60/825,607, filed on Sep. 14, 2006.

(76) Inventor: **Martin B. Rawls-Meehan,**
Lexington, MA (US)

Publication Classification

(51) **Int. Cl.**
A61G 7/018 (2006.01)
(52) **U.S. Cl.** **5/600**

Correspondence Address:
STRATEGIC PATENTS P.C.,
C/O PORTFOLIOIP, P.O. BOX 52050
MINNEAPOLIS, MN 55402

(57) **ABSTRACT**

Aspects of this invention relate to an adjustable bed that may include one or more articulating portions, and may include one or more components, including an air inflatable mattress associated with the adjustable bed frame, a programmable logic controller, a remote memory storage facility, a remote storage location of user preferences, a cell phone remote control, a modular control device, an air purification facility, a power outlet controller, a Bluetooth remote control, an ultra wide band remote control, a wireless USB remote control, and the like.

(21) Appl. No.: **11/875,852**

(22) Filed: **Oct. 20, 2007**

Related U.S. Application Data

(63) Continuation of application No. 11/855,354, filed on Sep. 14, 2007.

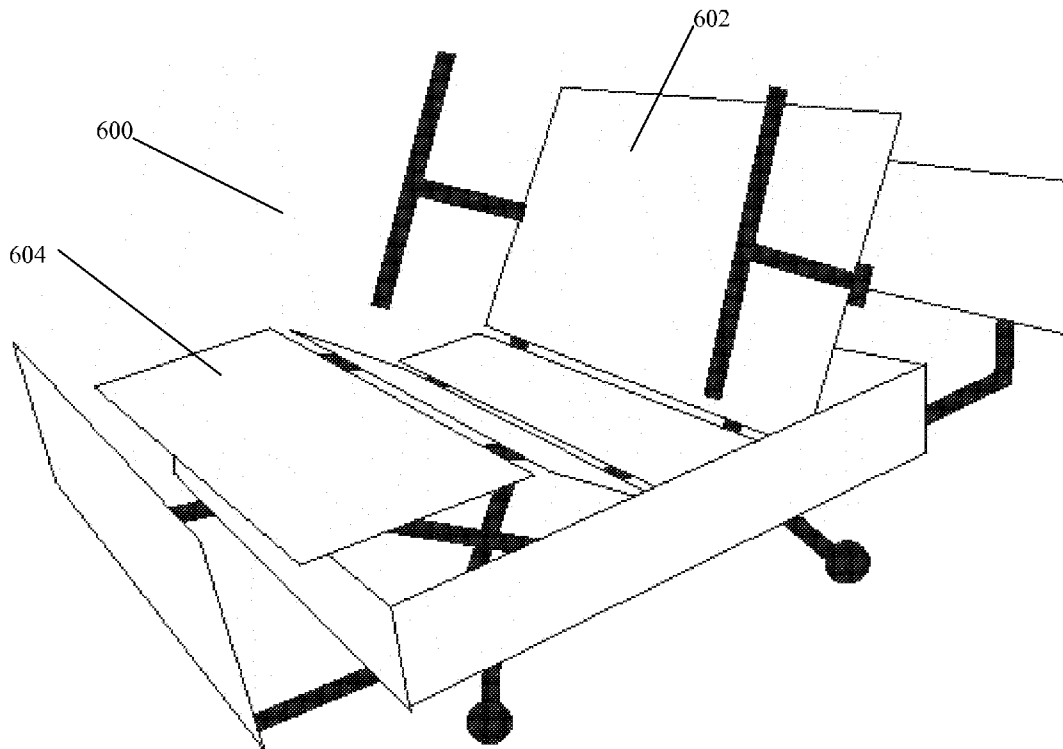

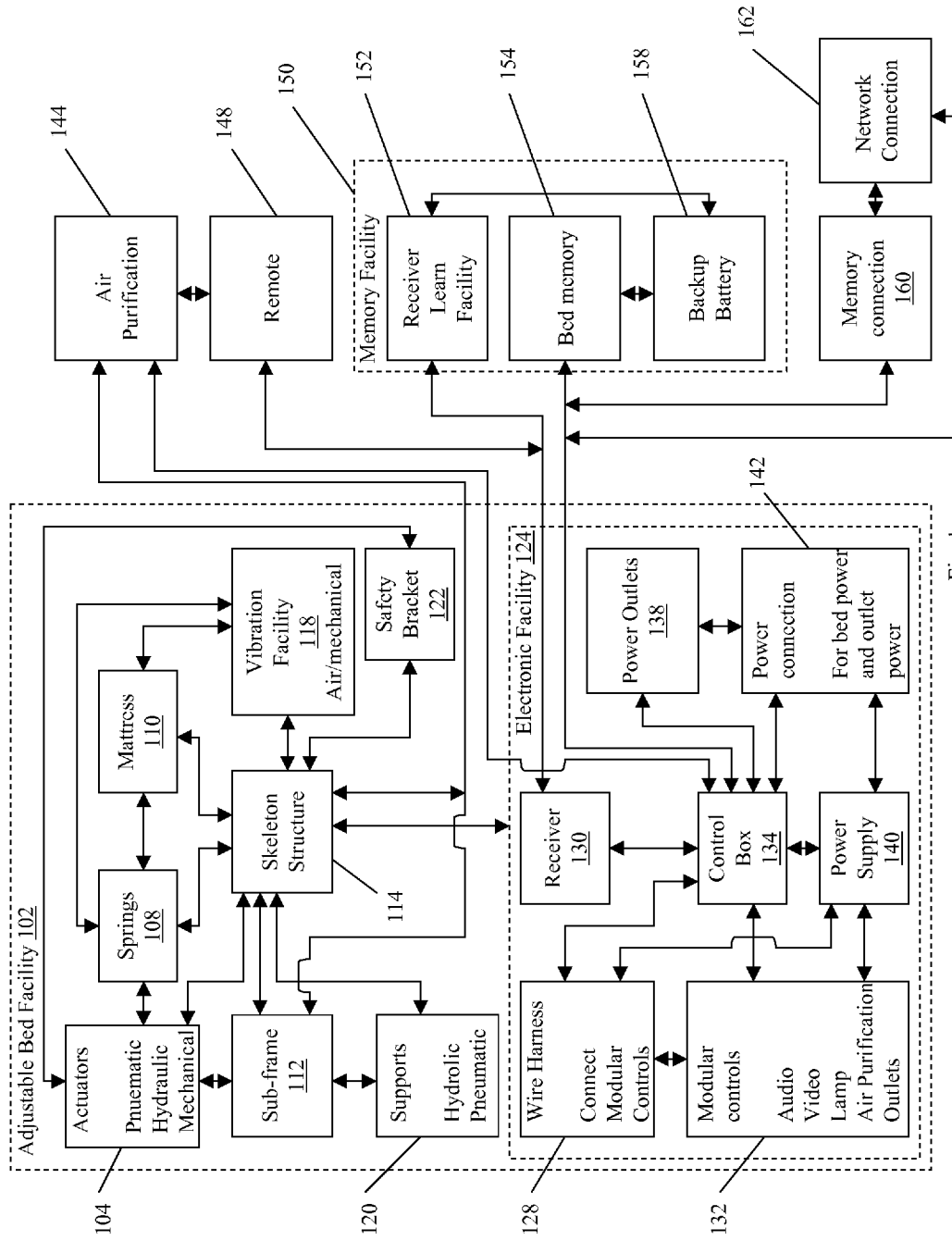

Fig. 1

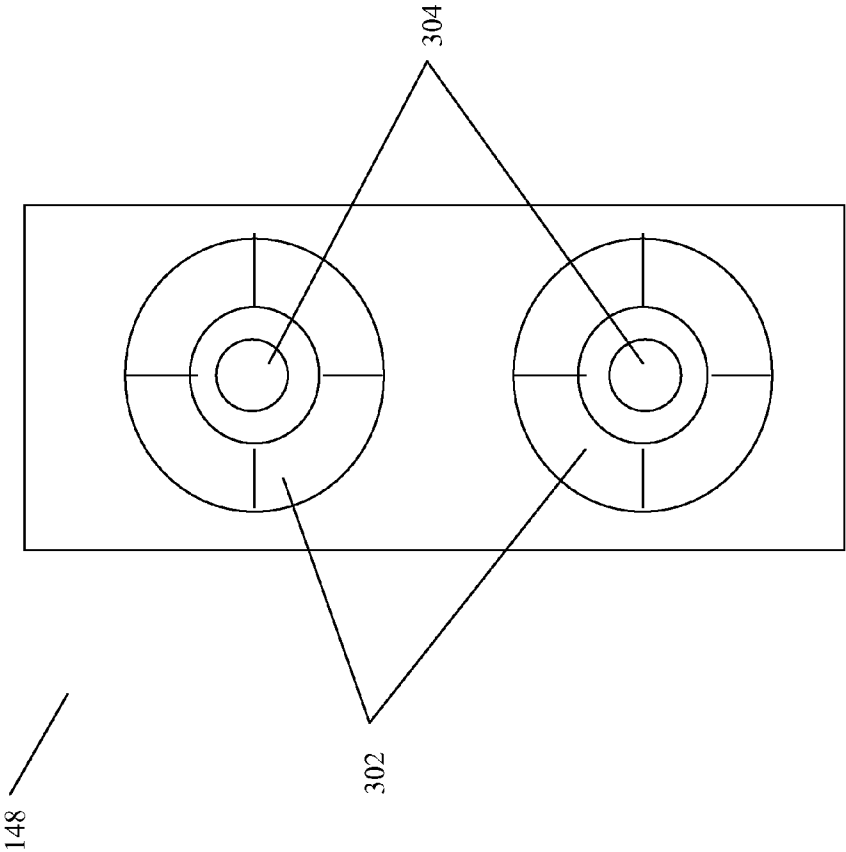

Fig. 3

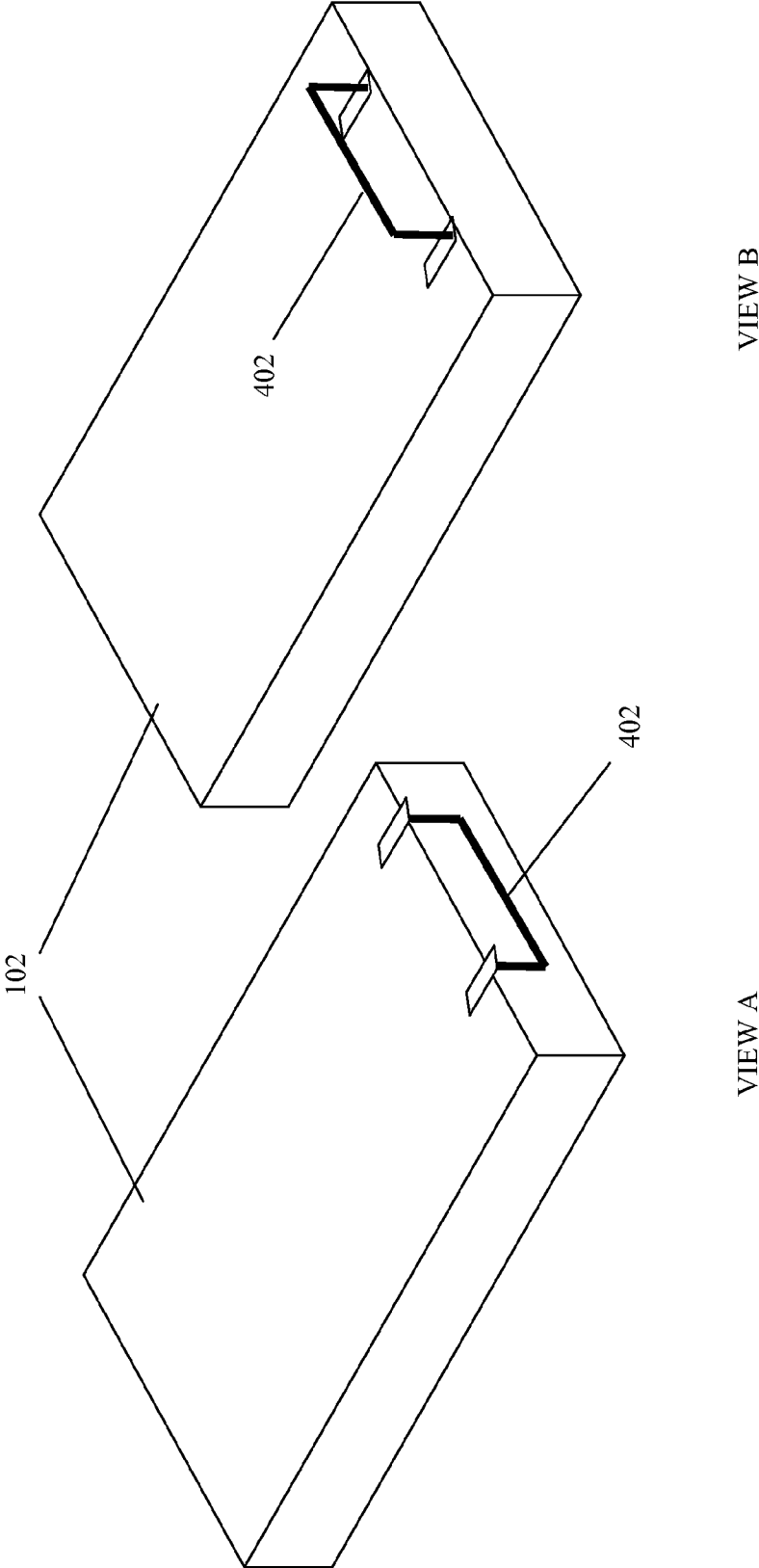

Fig. 4

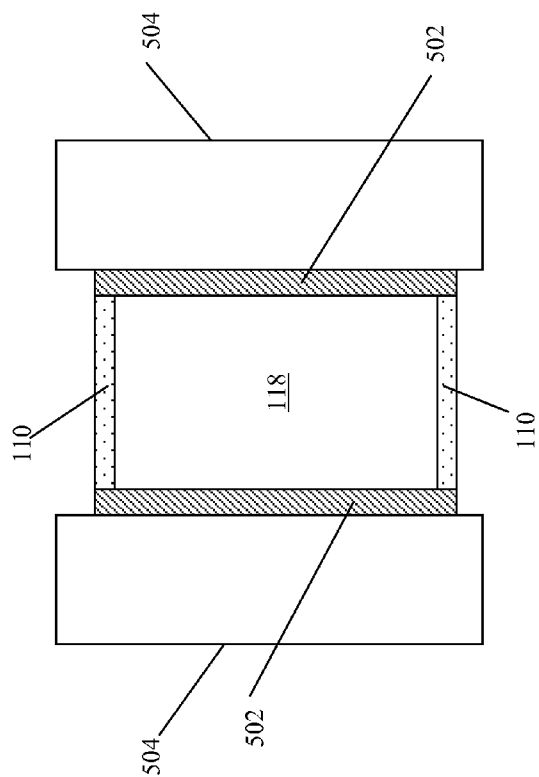

Fig. 5A

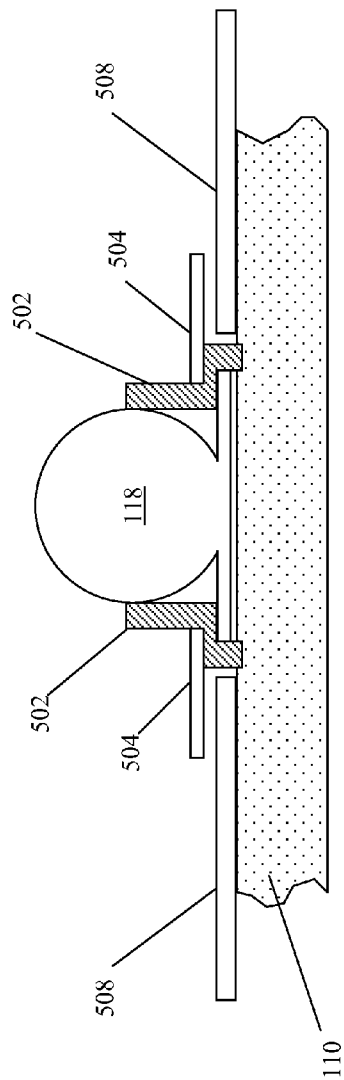

Fig. 5B

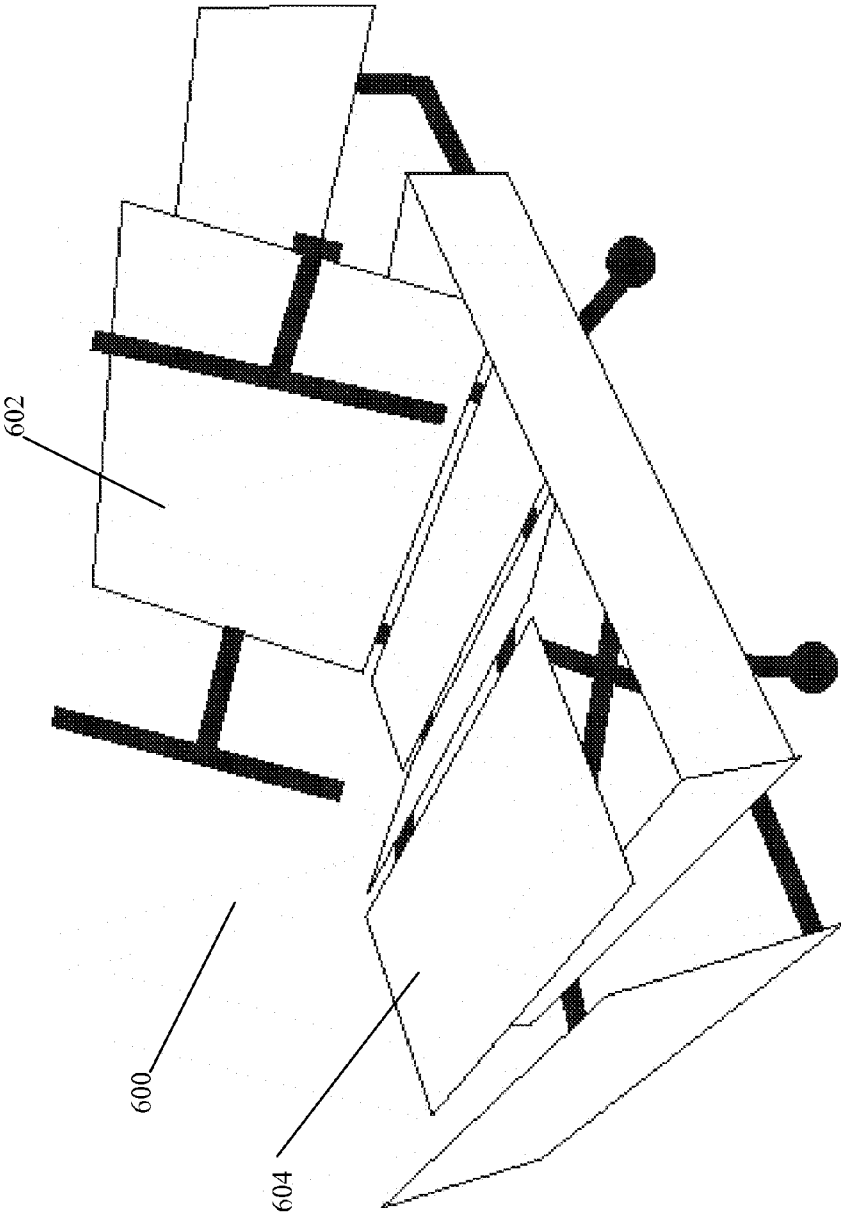

Fig. 6

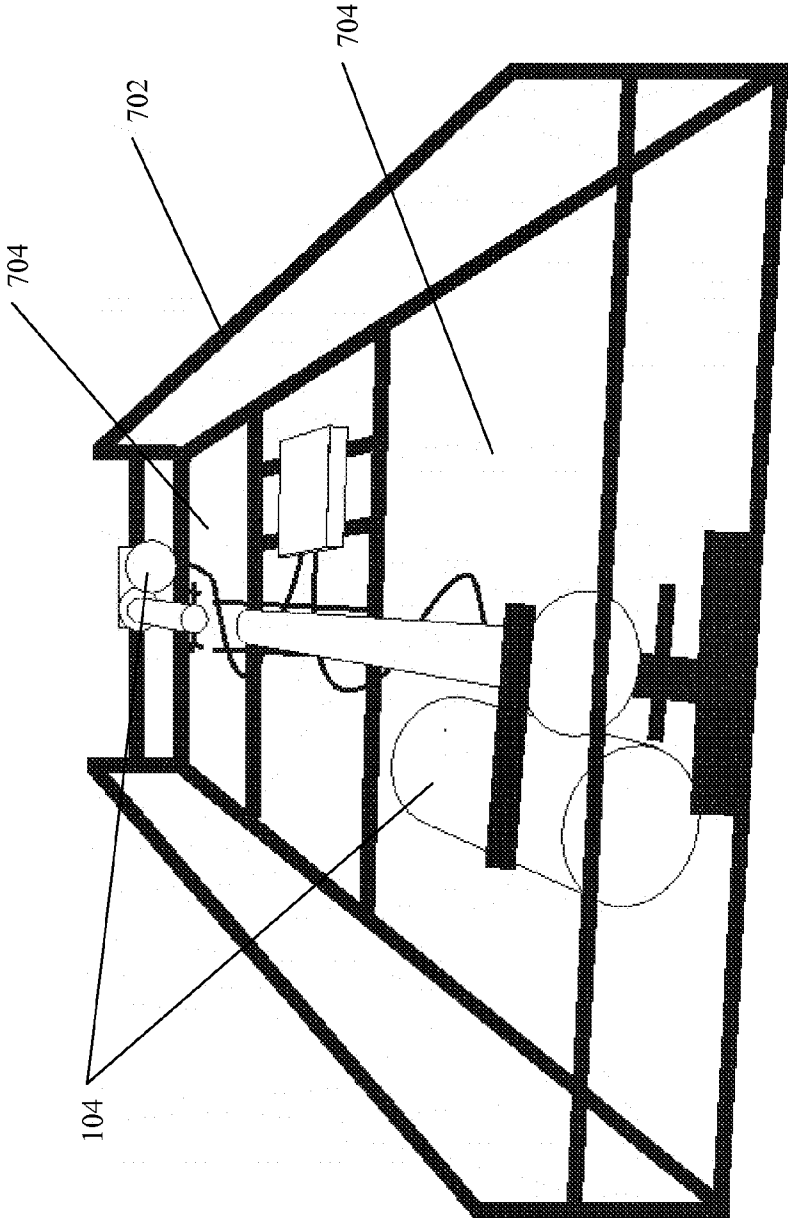

Fig. 7

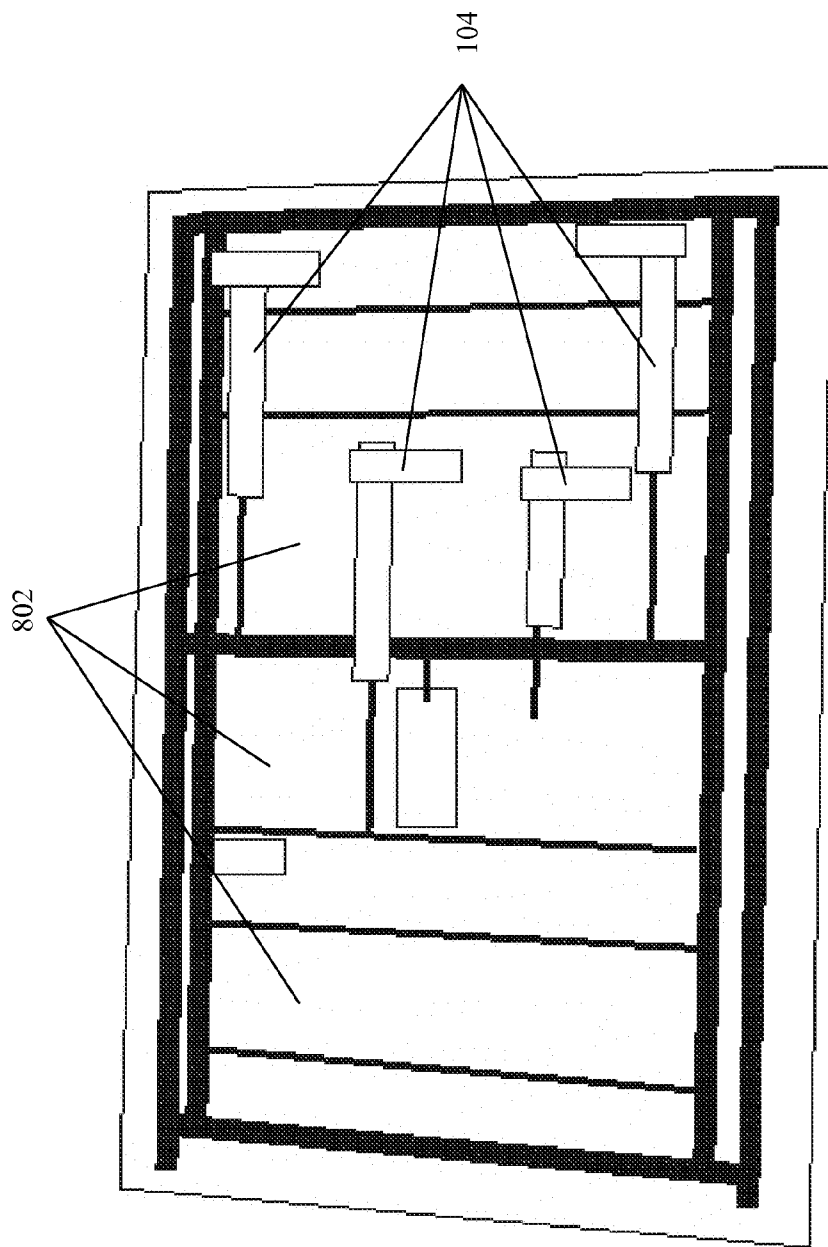

Fig. 8

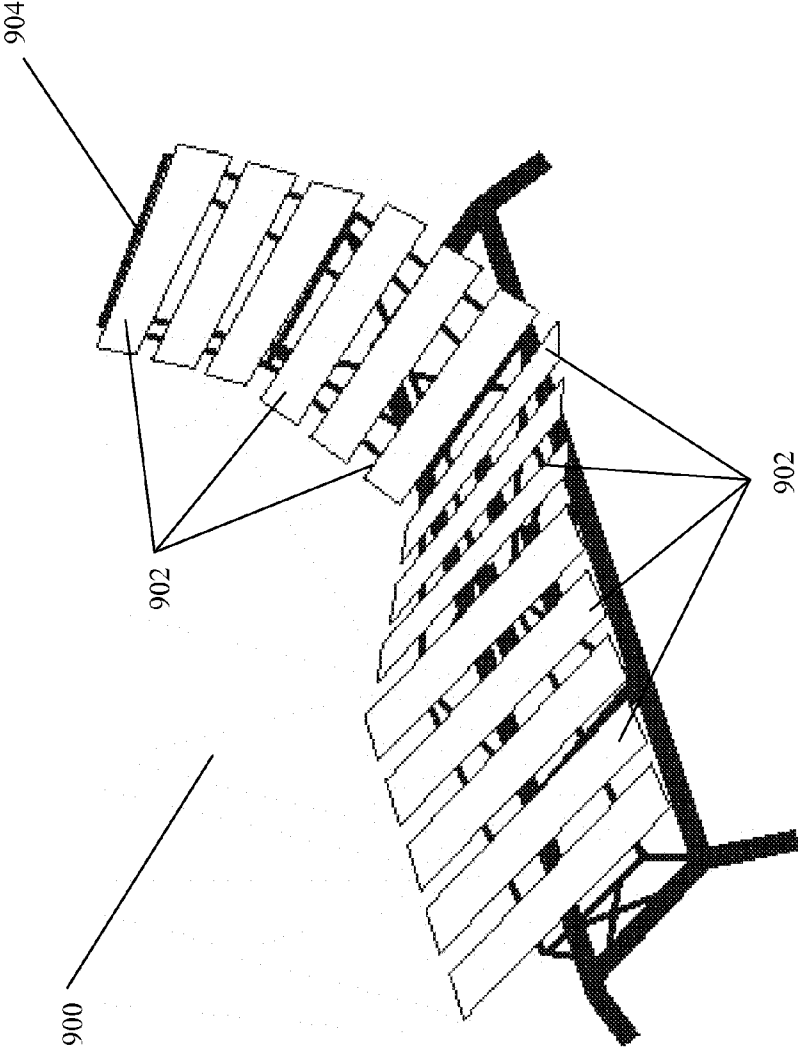

Fig. 9

**METHODS AND SYSTEMS OF AN
ADJUSTABLE BED**

**CROSS-REFERENCE TO RELATED
APPLICATIONS**

[0001] This application claims the benefit of the U.S. Provisional. App. No. 60/825,607 filed on Sep. 14, 2006.
[0002] In an embodiment, the adjustable bed systems and methods described herein could be used in combination with the systems and methods disclosed in U.S. Provisional Patent Application No. 60/823,891 filed on Aug. 29, 2006, and incorporated by reference herein.

BACKGROUND

[0003] 1. Field
[0004] This invention relates to an adjustable bed.
[0005] 2. Background
[0006] Adjustable beds may contain at least one section of which a user may control the position. The user may typically adjust the bed by using a control to move the adjustable section in its direction of movement. Additionally, the adjustable bed may include various types of mattresses and vibration of sections. Often, users that have adjustable beds because a medical issue may require certain positions to aid recovery, positioning to relieve discomfort as a result of pain, or the like. These users may, because of these issues, spend significant amount of time in the adjustable beds, some users may be confined to bed.
[0007] Many existing adjustable beds may provide the basic requirements of moving bed sections to positions that are required by a user, but do not account for controlling other devices that may be beneficial to the user and provide for a level of independence to the user.
[0008] A typical adjustable bed may consist of a wood decking for each of the sections of the bed connected together with hinges to allow the various positions between the sections. There are actuators connected between the bed frame and the wood decking for moving the adjustable sections into user-desired positions. The adjustable bed may have a "wall hugging" feature that maintains a consistent distance between the mattress and the wall as the bed is adjusted. Some adjustable beds may use wooden or plastic slats to support the mattress instead of a solid wood platform.
[0009] The adjustable bed may have at least one actuator to position the adjustable bed sections. In some cases there is one actuator to position more than one, such as positioning both the thigh and foot sections with one actuator. There may also be more than one actuator for each adjustable section.
[0010] Hospitals have used adjustable beds for many years to provide comfortable and medical required positions.
[0011] A need exists for an adjustable bed that provides for the adjustable function required in an adjustable bed and provides for control of additional devices, a plurality of different bed section actuator types and movable memory types that may provide independent activities to the user of the adjustable bed.

SUMMARY

[0012] Provided herein are methods and systems for an adjustable bed facility. Aspects of this invention relate to an adjustable bed that may include one or more articulating portions, and may include one or more components, including an air inflatable mattress associated with the adjustable

bed frame, a programmable logic controller, a remote memory storage facility, a remote storage location of user preferences, a cell phone remote control, a modular control device, an air purification facility, a power outlet controller, a Bluetooth remote control, an ultra wide band remote control, a wireless USB remote control, and the like
[0013] An apparatus disclosed herein includes an adjustable bed that may include one or more articulating portions, including an air inflatable mattress associated with the adjustable bed frame, where the air adjustable mattress may be associated with an air pump to regulate the air pressure in the air inflatable mattress, the air inflatable mattress may include flex regions about which the air inflatable mattress can flex, a programmable logic controller (PLC) may be associated with the adjustable bed frame adapted to control at least one adjustable aspect of the adjustable bed, and the like.
[0014] An apparatus disclosed herein includes an adjustable bed that may include one or more articulating portions, including an air inflatable mattress associated with the adjustable bed frame, where the air adjustable mattress may be associated with an air pump to regulate the air pressure in the air inflatable mattress, the air inflatable mattress may include flex regions about which the air inflatable mattress may flex, a remote memory storage facility may be adapted to be removeably and replaceably connected to an adjustable bed frame controller associated with the adjustable bed frame, the remote memory may include information relating to at least one operational parameter related to control of the adjustable bed, and the like.
[0015] An apparatus disclosed herein includes an adjustable bed that may include one or more articulating portions, including an air inflatable mattress associated with the adjustable bed frame, where the air adjustable mattress may be associated with an air pump to regulate the air pressure in the air inflatable mattress, the air inflatable mattress may include flex regions about which the air inflatable mattress may flex, a remote storage location of user preferences, where the user preferences may represent recall parameters relating to one or more adjustable aspects of the adjustable bed, and the like.
[0016] An apparatus disclosed herein includes an adjustable bed that may include one or more articulating portions, including an air inflatable mattress associated with the adjustable bed frame, where the air adjustable mattress may be associated with an air pump to regulate the air pressure in the air inflatable mattress, the air inflatable mattress may flex regions about which the air inflatable mattress can flex, a cell phone remote control may be adapted to control at least one adjustable aspect of the adjustable bed, and the like.
[0017] An apparatus disclosed herein includes an adjustable bed that may include one or more articulating portions, including an air inflatable mattress associated with the adjustable bed frame, where the air adjustable mattress may be associated with an air pump to regulate the air pressure in the air inflatable mattress, the air inflatable mattress may include flex regions about which the air inflatable mattress may flex, a modular control device, where the modular control device may be adapted to control at least one aspect of the adjustable bed, and the like.
[0018] An apparatus disclosed herein includes an adjustable bed that may include one or more articulating portions, including an air inflatable mattress associated with the adjustable bed frame, where the air adjustable mattress may be associated with an air pump to regulate the air pressure in the air inflatable mattress, the air inflatable mattress may include

flex regions about which the air inflatable mattress may flex, an air purification facility associated with the adjustable bed, and the like.

[0019] An apparatus disclosed herein includes an adjustable bed that may include one or more articulating portions, including an air inflatable mattress associated with the adjustable bed frame, where the air adjustable mattress may be associated with an air pump to regulate the air pressure in the air inflatable mattress, the air inflatable mattress may include flex regions about which the air inflatable mattress may flex, a power outlet controller may be adapted to control at least one parameter of a power outlet associated with the adjustable bed, and the like.

[0020] An apparatus disclosed herein includes an adjustable bed that may include one or more articulating portions, including an air inflatable mattress associated with the adjustable bed frame, where the air adjustable mattress may be associated with an air pump to regulate the air pressure in the air inflatable mattress, the air inflatable mattress may include flex regions about which the air inflatable mattress may flex, a Bluetooth remote control may be adapted to control at least one adjustable aspect of the adjustable bed, and the like.

[0021] An apparatus disclosed herein includes an adjustable bed that may include one or more articulating portions, including an air inflatable mattress associated with the adjustable bed frame, where the air adjustable mattress may be associated with an air pump to regulate the air pressure in the air inflatable mattress, the air inflatable mattress may include flex regions about which the air inflatable mattress may flex; an ultra wide band (UWB) remote control adapted to control at least one adjustable aspect of the adjustable bed, and the like.

[0022] An apparatus disclosed herein includes an adjustable bed that may include one or more articulating portions, including an air inflatable mattress associated with the adjustable bed frame, where the air adjustable mattress may be associated with an air pump to regulate the air pressure in the air inflatable mattress, the air inflatable mattress may include flex regions about which the air inflatable mattress may flex, a wireless USB remote control adapted to control at least one adjustable aspect of the adjustable bed, and the like.

[0023] An apparatus disclosed herein includes an adjustable bed that may include one or more articulating portions, including a programmable logic controller (PLC) associated with the adjustable bed frame that may be adapted to control at least one adjustable aspect of the adjustable bed, a remote memory storage facility that may be adapted to be removeably and replaceably connected to the PLC, where the remote memory may include information relating to at least one operational parameter related to control of the adjustable bed, and the like.

[0024] An apparatus disclosed herein includes an adjustable bed that may include one or more articulating portions, including a programmable logic controller (PLC) associated with the adjustable bed frame that may be adapted to control at least one adjustable aspect of the adjustable bed, a remote storage location of user preferences, where the user preferences may represent recall parameters accessible by the PLC relating to one or more adjustable aspects of the adjustable bed, and the like.

[0025] An apparatus disclosed herein includes an adjustable bed that may include one or more articulating portions, including a programmable logic controller (PLC) associated with the adjustable bed frame that may be adapted to control

at least one adjustable aspect of the adjustable bed, a cell phone remote control that may be adapted to control at least one adjustable aspect of the adjustable bed by communicating with the PLC, and the like.

[0026] An apparatus disclosed herein includes an adjustable bed that may include one or more articulating portions, including a programmable logic controller (PLC) associated with the adjustable bed frame that may be adapted to control at least one adjustable aspect of the adjustable bed, a modular control device, where the modular control device may be adapted to control at least one aspect of the adjustable bed by communicating with the PLC, and the like.

[0027] An apparatus disclosed herein includes an adjustable bed that may include one or more articulating portions, including a programmable logic controller (PLC) associated with the adjustable bed frame that may be adapted to control at least one adjustable aspect of the adjustable bed, an air purification facility that may be associated with the adjustable bed, and the like.

[0028] An apparatus disclosed herein includes an adjustable bed that may include one or more articulating portions, including a programmable logic controller (PLC) associated with the adjustable bed frame that may be adapted to control at least one adjustable aspect of the adjustable bed, a power outlet controller that may be adapted to control at least one parameter of a power outlet associated with the adjustable bed by communicating with the PLC, and the like.

[0029] An apparatus disclosed herein includes an adjustable bed that may include one or more articulating portions, including a programmable logic controller (PLC) associated with the adjustable bed frame that may be adapted to control at least one adjustable aspect of the adjustable bed, a Bluetooth remote control that may be adapted to control at least one adjustable aspect of the adjustable bed by communicating with the PLC, and the like.

[0030] An apparatus disclosed herein includes an adjustable bed that may include one or more articulating portions, including a programmable logic controller (PLC) associated with the adjustable bed frame that may be adapted to control at least one adjustable aspect of the adjustable bed, an ultra wide band (UWB) remote control that may be adapted to control at least one adjustable aspect of the adjustable bed by communicating with the PLC, and the like.

[0031] An apparatus disclosed herein includes an adjustable bed that may include one or more articulating portions, including a programmable logic controller (PLC) associated with the adjustable bed frame that may be adapted to control at least one adjustable aspect of the adjustable bed, a wireless USB remote control that may be adapted to control at least one adjustable aspect of the adjustable bed by communicating with the PLC, and the like.

[0032] An apparatus disclosed herein includes an adjustable bed that may include one or more articulating portions, including a remote memory storage facility that may be adapted to be removeably and replaceably connected to an adjustable bed frame controller associated with the adjustable bed frame, where the remote memory may include information relating to at least one operational parameter related to control of the adjustable bed. In addition, the remote memory storage facility may store user preferences, the user preferences may represent recall parameters relating to one or more adjustable aspects of the adjustable bed, and the like.

[0033] An apparatus disclosed herein includes an adjustable bed that may include one or more articulating portions,

[0068] These and other systems, methods, objects, features, and advantages of the present invention will be apparent to those skilled in the art from the following detailed description of the preferred embodiment and the drawings. All documents mentioned herein are hereby incorporated in their entirety by reference.

BRIEF DESCRIPTION OF FIGURES

[0069] The systems and methods described herein may be understood by reference to the following figures:

[0070] FIG. 1 shows a block diagram of an adjustable bed facility and associated components.

[0071] FIG. 2 shows an embodiment of two methods of maintaining user memory for storing user preferred adjustable bed positions.

[0072] FIG. 3 shows an embodiment of a remote control used to command the adjustable bed facility.

[0073] FIG. 4 shows an embodiment of the shipping of a mattress retainer bracket in the upside down position.

[0074] FIG. 5A shows a top view of a vibration motor within an opening of a adjustable bed facility section lateral surface.

[0075] FIG. 5B shows a side view of a vibration motor within an opening of an adjustable bed facility lateral surface.

[0076] FIG. 6 shows a typical hospital adjustable bed.

[0077] FIG. 7 shows one use of actuators connected to the bed frame and the adjustable sections.

[0078] FIG. 8 shows more than one actuator for each adjustable bed section, in this case there are two actuators for each adjustable section.

[0079] FIG. 9 shows an adjustable bed using slats instead of wood decking for the foundation of the adjustable sections.

DETAILED DESCRIPTION OF FIGURES

[0080] In the following description, terms such as ‘adjustable mattress’, ‘adjustable bed’, ‘adjustable bed facility’ and the like are used interchangeably to refer generally to an apparatus including a sleeping or resting surface with one or more adjustable or moveable sub-surfaces that can be positioned for user comfort and/or convenience, unless a specific meaning is explicitly provided or otherwise clear from the context

[0081] As users spend more and more time in adjustable beds they may desire to have a level of independence by controlling devices that may be in the room from the adjustable bed. The devices and facilities that users may wish to control may include audio equipment, video equipment, lamps, air purification facilities, power outlets, and the like. It may be desirable for the user to control these devices and facilities from the adjustable bed without having to leave the bed or ask for aid from someone else. For example, the user may be confined to the bed and may want the simple ability to control the lights around the adjustable bed.

[0082] In an embodiment, an adjustable bed may not be the only rest facility to benefit from position and additional function control. Users may also use beds, adjustable beds, adjustable chairs, adjustable couches, and the like to provide comfortable positions when the user may have limited mobility. For example, a user that has had hip replacement surgery may not be confined to bed but may require a chair or couch to be adjustable to provide a comfortable sitting position while providing control of other devices within the room to limit the number of times the user must get up and adjust the devices.

In an embodiment, while recovering from a surgery, an injury, an illness, or the like, the user may use more than one type of rest facility. The user may require confinement to an adjustable bed for a time and then, with health improvement, be able to move to either an adjustable chair or adjustable couch.

[0083] Aspects of the invention may be described as an adjustable bed, but it may be understood that the same aspects may be applied to other rest facilities that may include a bed, a couch, a chair, or the like. Such rest facilities may be in a home, a car, a recreational vehicle, a cruise ship, an airline, a train, or anywhere that a user required them, and they may be fixed or mobile.

[0084] One aspect of this invention may be to provide the adjustable bed with more than one power option to move the adjustable bed sections. The adjustable bed may use electric motors with gearboxes, pneumatic springs, hydraulic springs, or the like to actuate the adjustable bed sections. There may be both pricing and durability reasons to have the different actuation types.

[0085] Another aspect of this invention may be to provide the ability to provide additional functionality to the adjustable bed by using modular controls that may be able to communicate with the user’s interface control. The modular controls may be designed to control a number of additional devices and facilities that may include audio devices, video devices, lamps, air purification facilities, power outlets, and the like.

[0086] Another aspect of the adjustable bed may be to provide a support structure to support the bed materials (e.g. mattress), motors, actuators, hinges between bed sections, and the like. The support structure may be a frame structure to provide the support yet remain lightweight.

[0087] Another aspect may be the use of replaceable memory to maintain the bed memory and software applications. The replaceable memory may allow user specific information to be moved from one adjustable bed to another adjustable bed. This may be useful in care facilities where a user may move from one bed to another bed during the stay in the care facility. If the user has saved a preferred positioning of the adjustable bed, when the user moves to another bed, the preferred positioning settings may be moved to the other bed with the user.

[0088] Another aspect of the adjustable bed may be to provide safety features that may control the retraction of the adjustable bed sections to reduce the risk of crushing an object that may be under the adjustable bed.

[0089] Now referring to FIG. 1, a block diagram of the various components of the adjustable bed facility 102 is shown. In an embodiment, an adjustable bed facility 102 may be made up of a number of devices and facilities that may include actuators 104, springs 108, mattresses 110, a sub-frame 112, a skeleton structure 114, vibration motors 118, supports 120, safety brackets 122, an electronic facility 124, an air purification facility 144, a remote 148, a memory facility 150, a memory connection 160, a network connection 162, and the like. In an embodiment, the electronic facility 124 may include a wire harness 128, a receiver 130, modular controls 132, a control box 134, power outlets 138, a power connection 142, and the like. In an embodiment, the memory facility 150 may include a receiver learn facility 152, bed memory 154, a backup battery 158, and the like. In an embodiment, the receiver learn facility 152, bed memory 154, and backup battery 158 may not be part of the memory facility 150, but may be combined into other facilities or devices, be stand-alone devices, or the like.

[0090] In an embodiment, the physical aspects of the adjustable bed facility 102 that provide support for the user may include the actuators 104, springs 108, mattresses 110, a sub-frame 112, a skeleton structure 114, vibration motors 118, supports 120, and safety brackets 122.

[0091] In an embodiment, the skeleton structure 114 may provide the central structure that the other physical aspects may interact with. In an embodiment, the skeleton structure 114 may provide direct support to the mattress 110, springs 108, and the like. In an embodiment, the skeleton structure 114 may be a lightweight frame structure that may provide both the strength and rigidity required to properly support the mattress 110 and springs 108. In embodiments, the skeleton structure 114 may use materials that include metal, plastic, wood, or the like; the materials may be used individually or in combination.

[0092] In an embodiment, springs 108 may be used with a mattress 110, instead of a mattress 110, or the like. In an embodiment, the springs may be a standard bed spring system (e.g. coils within a wire framework), individual coil springs, individual foam springs, air springs, or the like. In an embodiment, the individual springs (e.g. coil, foam, or air) may be used to provide variable firmness to provide comfort to the user. For example, the springs 108 may be less firm or firmer in a local area to provide the user with the support that may be required for a body location that is experiencing discomfort (e.g. a hip, shoulder, back, neck). Springs that may have local firmnesses will be described in more detail below.

[0093] In an embodiment, the mattress 110 may include foam, feathers, springs 108, material, or the like. In an embodiment, the different materials may be used individually or in combination. The mattress may be intended to provide the user with a firmness that provides for the comfort requirements of the user.

[0094] In an embodiment, the mattress 110 may be an air mattress 110. In an embodiment, the air mattress 110 may be constructed using a single chamber, a plurality of chambers, a plurality of individual chambers, a combination of chamber shapes, or the like. In an embodiment, the air mattress 110 may be inflated to various pressures that may provide the user with the desired comfort level. In an embodiment, there may be separate air mattresses 110 for each of the adjustable bed facility 102 sections. For example, there may be separate air mattresses 110 for the head, torso, and foot sections of the adjustable bed facility 102. In an embodiment, the inflation pressure of the individual air mattresses 110 may be different from each other depending on user settings.

[0095] In an embodiment, the adjustable bed facility 102 sections may each contain individual air mattresses 110. For example, the head, torso, and foot sections may each have individual air mattresses that may be individually controlled for air pressures and therefore firmness. In an embodiment, the user may be able to control the firmness of the individual air mattresses 110 using a remote 148. In an embodiment, the remote 148 may have indicators for each of the firmness adjustable air mattresses 110. For example, the remote 148 may have keys for increasing or decreasing the pressures of the individual air mattresses 148. Using the remote 148, the user may be able to adjust the firmness of the adjustable bed facility sections.

[0096] In an embodiment, the air mattress 110 may use a common air supply source facility as an air actuator 104. In an embodiment, a control box 134 may control both the air

mattress 110 and air actuator 104. The control box 134 may provide controlling commands to both the air mattress 110 and air actuators.

[0097] In an embodiment, the skeleton structure 114 may have structural members that support the mattress 110 and springs 108 and may also provide support and connections for the actuators 104, sub-frame 112, supports 120, vibrator motors 118, safety bracket 122, and the like. In an embodiment, the structural members may be positioned on the peripheral edges of the mattress 110 and springs 108 to provide overall support and rigidity to the mattress 110 and springs 108 and may form the base of the individual adjustable bed facility 102 sections. Additionally, there may other structural members as support, cross pieces, or the like that may provide additional support to the mattress 110 and springs 108 as may be required. A person knowledgeable in the art may understand that the frame structure may have many different construction configurations to provide support and rigidity to the mattress 110 and springs 108.

[0098] In an embodiment, the skeleton structure 114 may form the base of the adjustable bed facility 102 sections that may be moved relative to each other to provide the various bed positions required by the user. The adjustable bed facility 102 may include more than one section; a section may be fixed or may be adjustable. For example, the typical adjustable bed may have adjustable sections for the head, leg, and foot while the torso section may remain fixed and horizontal. There may be different combinations of movable and fixed sections with one or all of the sections being movable. In an embodiment, the sections may include the skeleton structure 114, mattress 110, springs 108, and the like and may individually be small mattress structures of the entire adjustable bed facility 102 mattress.

[0099] In an embodiment, the adjustable bed sections may be connected together using hinges or like devices that allow a freedom of motion between two adjacent adjustable bed facility 102 sections. In an embodiment, one section of the adjustable bed may remain fixed, such as the torso section, and act as the foundation for the other movable sections to be positioned. In an embodiment, any or none of the sections may be a fixed foundation section in the adjustable bed facility 102. In embodiments, there may be more than one adjustable bed facility 102 configuration depending on the requirements of a user, cost requirements, medical needs, or the like. For example, there may be a configuration where only the head section is adjustable to provide the user with the ability to have an elevated upper body position. This configuration may be a single purpose bed but may also provide the user with a less expensive adjustable bed facility 102 that meets the user's needs. One skilled in the art may understand that there may be many different adjustable bed facility configurations containing fixed and moveable sections.

[0100] In an embodiment, the skeleton structure 114, as part of each adjustable bed facility 102 section, may also provide support and connection members for the components that may be used to move the various adjustable bed facility 102 sections. There may be skeleton structure 114 members that provide connection support to the actuators 104, supports 120, safety brackets 122, vibration motors 118, and the like. These support and connection members may have any shape or configuration required to provide the support and connections needed by the various other components. For example, in addition to the skeleton structure 114 that is used to provide support to the mattress 110 and springs 108 there may be at

least one cross member that may provide a connection to the actuator **104** and safety bracket **122**.

[0101] In an embodiment, the skeleton structure **114** and the sub-frame **112** may interface with each other; the sub-frame **112** may provide structural support and a rigid foundation base to the skeleton structure **114**. In an embodiment, the sub-frame **112** may be the rigid structure that is in contact to the floor and may provide a base for any fixed adjustable bed facility **102** sections and an interface for any movable adjustable bed facility **102** sections. In an embodiment, the sub-frame **112** legs may be connected to the sub-frame **112** using a threaded stud into threads of the sub-frame **112**. In an embodiment, to prevent the threaded stud from pulling out of the legs during tightening, the head of the threaded stud may be fixed between two or more layers of leg material. This construction may trap the threaded stud head to prevent it from moving away from the end of the leg and may also prevent the threaded stud head from being pulled through the end of the leg during the tightening of the leg to the sub-frame. In addition, the two or more layers of leg material may provide for added strength to the sub-frame **112** legs to prevent distortion at the sub-frame **112** and leg interface. In an example of a fixed torso section, the sub-frame **112** may provide a base to solidly connect the torso section to provide a fixed non-moving section. The other moveable sections may be moveably connected to the fixed torso section and additionally supported by the sub-frame **112** using a moveable interface connection.

[0102] In an embodiment, the sub-frame **112** may have structural members that may run along the length of the adjustable bed facility **102**, run along the width of the adjustable bed facility **102**, run diagonally across the adjustable bed facility **102**, or other orientation in relation to the adjustable bed facility **102** that may be required for support or connection to components.

[0103] In an embodiment, the skeleton structure **114** may be used as an RF antenna for receiving communication from the remote **148**. In embodiment, the entire skeleton structure **114** may be used as an antenna; a portion of the skeleton structure **114** may be used as an antenna, or the like.

[0104] In one embodiment, the sub-frame **112** may provide solid connections for any fixed section and skeleton structure **114** by rigidly connecting the skeleton structure **114** directly to the sub-frame **112**. In this manner, any fixed section and skeleton structure **114** may be rigidly connected to the sub-frame **112**, and through the sub-frame **112**, rigidly connected to the floor.

[0105] In another embodiment, the sub-frame **112** may provide an interface for the fixed adjustable bed facility **102** section and skeleton structure **114** where the fixed section may be able to move or slide in relation to the sub-frame **112**. By providing a non-rigid interface connection between the sub-frame **112** and the skeleton structure **114**, the fixed adjustable bed facility **102** section may have a freedom of motion but still may be supported by the sub-frame in a solid foundation manner. For example, the fixed adjustable bed facility **102** section may have wheels that run in a track, groove, "C" channel, or the like of the sub-frame **112** and may be able to move horizontally during the motion of one or more of the movable adjustable bed facility **102** sections. In an embodiment, the horizontal freedom of motion may provide for a "wall hugger" feature where, as the head section is adjusted up or down, the fixed torso section may move, along with the head section, horizontally forward and away from an

adjacent wall to maintain a fixed distance between the head section and the wall, therefore "hugging" the wall. It may be understood by one skilled in the art that the moveable interface between the skeleton structure **114** and sub-frame **112** may be any type of interface that may allow freedom of motion between the sub-frame **112** and skeleton structure **114**.

[0106] In an embodiment, any adjustable sections may have two connections, a first connection may be provided by a hinge type connection and a second connection may be the connection with the actuator **104** and safety bracket **122** that may provide the force to rotate the adjustable bed facility **102** section up or down. In an embodiment, the hinge type connection between the skeleton structure **114** of a first section and a second section may provide the point of rotation for the section motion. In an embodiment, the adjustable bed facility **102** may contain more than one section and any or all of the sections may be connected by a hinge type connection.

[0107] In an embodiment, there may be a support gusset for connection between the actuator **104** and the adjustable bed facility **102** section. In embodiments, the gusset may be an I beam, a T beam, an L beam, a box beam, or any other beam design that may provide the strength to lift the combined weight of the adjustable bed facility **102** section and the user without bending. In an embodiment, to resist bending forces at the connections to the actuator **104** and the adjustable bed facility **102** section, the ends of the gusset may be reinforced. In embodiments, the reinforcement may be an additional bracket added to the ends of the gusset, such as a U bracket or other bracket shape, to provide for increased material thickness and strength of the gusset ends. The thickness of the additional bracket may be determined by the amount of force and torque that may need to be resisted during the adjustable bed facility **102** section movement.

[0108] With the adjustable bed facility **102** sections interconnected using hinge type connections there may be at least one actuator **104** that may provide a connection between a fixed adjustable bed facility **102** section and a moveable section. In an embodiment, the hinge connection between the adjustable bed facility **102** sections may be a pivot point bracket that may include additional strengthening to resist bending forces. Similar to the gusset described above, the pivot point connections may have additional reinforcement, such as a U bracket or other shaped bracket, to provide for increased material thickness and strength to resist bending forces. The thickness of the additional bracket may be determined by the amount of force and torque that may need to be resisted during the adjustable bed facility **102** section movement. In an embodiment, the actuation **104** connection may be between two of the skeleton structures **114**. For example, a first end of the actuator **104** may be connected to the fixed torso section of the adjustable bed facility **102** and a second end of the actuator **104** may be connected to the section that is to be moved (e.g. head, leg, or foot sections). In an embodiment, the actuator **104** may use electric motors and mechanical gears, pneumatic pressure, hydraulic pressure, pneumatic spring, air spring, hydraulic spring or the like to provide the force to extend and retract the actuator **104**. The action of extending and retracting the actuator **104** may move the various movable bed sections up or down. By the actuator **104** pushing against the section, the section may rotate upward around the pivot point provided by the hinge type connection. In the same manner, by the actuator **104** pulling against the section, the section may rotate downward around the pivot

point provided by the hinge type connection. In an embodiment, there may be at least one actuator **114** for every moveable adjustable bed facility **102** section.

[0109] In an embodiment, the combination of actuator **114**, safety bracket **122**, and supports **120** may provide a safety feature to prevent an object that may be under the adjustable bed facility **102** from being damaged, impinged, crushed, or the like during the decent of the adjustable bed facility **102** section. During the downward motion of one adjustable bed facility **102** sections, the section may come in contact with an object that is under the adjustable bed facility **102**. If the actuator **104** is allowed to continue to pull the section in the downward direction, the object may be crushed under the force the actuator **104** may apply. In an embodiment, the safety bracket **122** may have a slot that may provide time to determine that there is an object under the section that is moving downward.

[0110] In an embodiment, the slot may have a first side that is on the opposite side of the slot from the actuator **104** and a second side that is on the same side as the actuator **104**. In an embodiment, the slot that is between the first side and the second side may be of any length. In an embodiment, the actuator may push against the first side to move the adjustable bed facility **102** section in an upward direction. In an embodiment, during the downward motion of the section, the actuator **104** may move at the same speed as the adjustable bed facility **102** section and therefore the actuator connection to the safety bracket **122** may remain within the safety bracket **122** slot without contacting either the first or second sides of the slot. In an embodiment, the section may move in the downward direction under the weight of the section without the actuator **104** pulling on the second side of the safety bracket **122**.

[0111] In an embodiment, the adjustable bed facility **102** section downward speed may be further controlled by supports **120** that may provide resistance to the section motion to control the rate of decent. In an embodiment, the support **120** may be a pressurized device using pneumatic pressure, hydraulic pressure, or the like to provide a resistive force to slow the decent of the adjustable bed facility **102** section. In an embodiment, the supports may provide enough resistance to control the rate of decent of the section as the actuator **104** is retracted.

[0112] In an embodiment, as the actuator **104** retracts, the adjustable bed facility **102** section, with the aid of the support **120**, may descend at the same rate as the as the actuator **104** is retracting. By matching the rates of the actuator **104** retraction and the adjustable bed facility **102** section descending, the actuator **104** connection within the safety bracket **122** slot may remain within the slot area and not contact either the first or second side of the slot. In an embodiment, as the section descends, if an object is encountered, the adjustable bed facility **102** section may stop its decent and the actuator **104** connection will move within the safety bracket **122** slot without pulling the section downward. In an embodiment, the amount of time that the actuator **104** connection is moving within the safety bracket **122** slot while the adjustable bed facility **102** section is stopped may provide time to the user to realize that an object has been contacted and to stop the downward motion of the section.

[0113] In an embodiment, an additional safety feature may be the addition of a shut off sensor, shut off switch, or the like on the first side of the safety bracket **122** slot to stop the retraction of the actuator **104** if the actuator **104** connection

comes in contact with the first side of the slot. In this manner, if the actuator **104** connection with the safety bracket **122** slot reaches the first side of the slot, the actuator **104** retraction may be stopped and the adjustable bed facility **102** section will not be forcibly pulled down into the object that may be under the section. In an embodiment, there may be an indication to the user that the actuator **104** connection has come in contact with the first side of the slot and the adjustable bed facility **102** sections downward motion has been stopped. In an embodiment, the indication may be an audio indication, a visual indication, a motion indication (e.g. vibration), or the like to indicate to the user that the motion has been stopped and there may be an obstruction with the adjustable bed facility **102** section.

[0114] In an embodiment, there may be at least one vibration motor **118** that may provide vibration and massage functions to the adjustable bed facility **102** sections and mattresses **110**. In an embodiment, there may be vibration motors **118** associated with any of the adjustable bed facility **102** sections. In an embodiment there may be more than one vibration motor **118** for each adjustable bed facility **102** section that may have vibration motors **118**. In an embodiment, using the remote **148**, the user may be able to control the vibration mode of the various vibration motors **118**; the mode may include the vibration setting for a particular bed section, the vibration frequency of at least one of the vibration motors, stopping the vibration of at least one of the vibration motors, or the like. In an embodiment, the vibration motors **118** may be operated independently or in combination. In an embodiment, the user may select a vibration mode on the remote **148** and the control box **134** may use a software application to control the various vibration motors **118** to the user's request.

[0115] In an embodiment, the vibration motor **118** may be an electric/mechanical device, a pneumatic device, a hydraulic device, or the like. The mechanical device may use an electric motor to rotate an offset mass to create a vibration; the vibration motor may be controlled for vibration frequency and amplitude by the speed of rotation of the electric motor. Referring to FIG. 5A and FIG. 5B, an embodiment of a vibration motor **118** is shown within an opening of a adjustable bed facility **102** support lateral surface **508**. The adjustable bed facility **102** section may have a lateral surface **508** and the lateral surface **508** may include an opening in which the vibration motor **118** may be located; the vibration motor **118** may fit within the opening such that the vibration motor **118** may not contact the lateral surface **508**.

[0116] In an embodiment, the vibration motor **118** may be secured to the adjustable bed facility **102** section using at least one bracket **504**. In an embodiment, when more than one bracket **504** is used, at least one of the brackets **504** may be separable and removable. In an embodiment, the at least one bracket **504** may be shaped to secure the vibration motor **118** within the section opening such as a straight bracket, a U shaped bracket, an L shaped bracket, or the like; in FIG. 5A and FIG. 5B the bracket **504** is shown as a straight bracket **504**. In an embodiment, the removal of one of the brackets **504** may facilitate securing the vibration motor **118** to the bed section, facilitating the servicing of the vibration motor **118**, or the like. The bracket **504** may be positioned such that at least one portion of the bracket **504** is within the opening of the lateral surface **508** and may also be positioned such that the bracket **504** may overlap the vibration motor **118** flange. The bracket **504** may provide support to the vibration motor **118** flange along a majority of the perimeter of the mattress

support opening. The bracket **504** may be coupled to the mattress support **508** using a removable coupling. Removing the bracket **504** may facilitate removing and servicing the vibration motor **118**. The vibration motor **118** flange may extend beyond the perimeter of the opening of the mattress support **508** and the resilient material **502** may provide positional support for the motor so that the flange may impart vibration to the mattress without contacting the mattress support. The resilient material **502** may provide mechanical insulation between the flange and the perimeter of the opening in the mattress support **508**. The resilient material **502** disposed between the flange and the lateral support **508** surface of the bracket **504** may further provide positional support for the vibration motor **118** housing.

[0117] The bracket **504** may be constructed using material such as plastic, metal, or the like, and may be constructed using the materials individually or in combination. In an embodiment, there may be a resilient material **502** associated with the brackets **504**, the resilient material may provide for dampening the vibration between the vibration motor **118** and the adjustable bed facility **102**, may contact the vibration motor **118** to secure the vibration motor **118** to the bed section, may provide for dampening of vibration to the adjustable bed facility **102** and hold the vibration motor **118** in place, or the like. The resilient material **502** may include latex foam, polyurethane foam, polypropylene foam, polyethylene foam, or the like and may be used individually or in combination.

[0118] In an embodiment, either of the pneumatic or hydraulic devices may act as a vibration motor **118** increasing and decreasing the pressure within a cylinder, bladder, or the like at certain frequencies to provide the vibration required by the user. In an embodiment, a device to provide the pressure frequency may be part of the vibration motor **118**, a separate device from the vibration motor **118**, or the like.

[0119] In an embodiment, the vibration facility **118** may be connected to the skeleton structure **114**, the mattress **110**, the lateral surface **508**, or the like where the vibration may be imparted into the adjustable bed facility **102** mattress **110** as desired by the user. In an embodiment, the vibration motor **118** flange may provide surface area that may impart a vibration into the mattress **110**. In another embodiment, the vibration motor **118** may be in proximity to a vibration distribution facility (not shown) that may aid in the propagation of vibration energy to the adjustable bed facility **102** section. In an embodiment, the vibration motor **118** may be operatively connected to the vibration distribution facility, may be in contact with the vibration distribution facility, may not be in contact with the vibration distribution facility, or the like. The vibration distribution facility may be constructed using materials such as plastic, rubber, metal, or the like and may be constructed using these materials individually or in combination. In an embodiment, the vibration distribution facility may provide for a more uniform distribution of the vibration characteristics of the vibration motor **118** and may have a size and shape relative to the size and shape of the adjustable bed facility **102** section.

[0120] Referring again to FIG. 1, in an embodiment, the adjustable bed facility **102** may have an electronic facility **124** that may contain components that provide control of the physical aspects of the adjustable bed facility **102** (e.g. actuator, vibration motors), interface with the remote **148**, interface with networks, interface with bed memory **154**, control electronic devices of the adjustable bed facility **102**, and the like.

[0121] In an embodiment, the control box **134** may coordinate the electronic requirements of the electronic facility **124**. In an embodiment, the control box **134** may interface with the receiver **130**, remote **148**, air purification facility **144**, power outlets, power connection **142**, power supply **140**, modular controls **132**, wire harness **128**, and the like. In an embodiment, the control box **134**, receiver **130**, and power supply **140** may be mounted directly to the skeleton structure **114**.

[0122] In an embodiment, the control box **134** may receive its command request from the user requesting adjustable bed facility **102** functions using the remote **148**. In an embodiment, the remote may communicate to the receiver **130** and the receiver may transmit the received user command request to the control box **134**. In an embodiment, the receiver **130** and control box **134** may be individual devices or a combined device.

[0123] In an embodiment, the remote **148** and receiver **130** may have wired or wireless communication. In an embodiment, the wireless communication may be by radio frequency (RF), infrared (IR), Bluetooth, or the like. In an embodiment, the receiver **130** may receive the user commands from the remote **130** and transmit the same command to the control box **134**; the receiver may not provide any interpretation of the remote **148** commands. In an embodiment, the remote **148** and receiver **130** may be communication matched by the use of a code key. The code key may be any indicator that may be interpreted by the remote **148** and receiver **130** that commands may be received and executed between the remote **148** and receiver **130**. In embodiments, the code key may be a number, a word, a serial number, a bed identification, a remote identification, a user identification, or any other identification known to both the remote **148** and receiver **130**, all an indication that communications should be received. The code key may be transmitted as the beginning of the communication, the end of the communication, as part of the communication or the like.

[0124] In an embodiment, the skeleton structure **114** may be used as an RF antenna for receiving communication from the remote **148** to the receiver **130**. In embodiment, the entire skeleton structure **114** may be used as an antenna; a portion of the skeleton structure **114** may be used as an antenna, or the like.

[0125] In an embodiment, the control box **134** may also control the functions of the adjustable bed facility **102** using a wireless technology in place of, or in coordination with, the wire harness **128**. In an embodiment, the wireless technology may include Bluetooth, ultra-wideband (UWB), wireless USB (WUSB), IEEE **802.11**, cellular, or the like. The various controlled functions (e.g. actuators **104** or external devices) may be able to communicate using the wireless technology, may use an intermediate wireless receiver, or the like to communicate with the control box **134**.

[0126] In an embodiment, the control box **134** wireless communication may use a wireless network protocol that may include peer-to-peer communication, master/slave communication, as a hub, as a server, or the like. In an embodiment, the wireless communication may be used to control more than one adjustable bed facility. For example, the user may be able to control his/her adjustable bed facility and may additionally be able to control another adjustable bed that may be within the range of the communication method.

[0127] In an embodiment, the cellular communication may utilize a cell phone, a smart phone, or the like to provide the communication method with the control box **134**, modular

controls **132**, or the like. In an embodiment, the control box **134** may be controlled by a programmable control circuit (PLC). In an embodiment, the user may use a menu on the cell phone for adjustable bed functions that may be controlled by the cell phone. For example, the cell phone technology may be able to control the bed position and vibration characteristics of the adjustable bed facility **102** and therefore the cell phone menu may present the user with options for controlling the bed position and vibration.

[0128] In an embodiment, if the communication between the remote **148** and receiver **130** is wireless, the receiver learn facility **152** may be used to establish the communication between them. In an embodiment, a learn protocol between the remote **148** and receiver **130** may be user initiated by pressing a button on the receiver learn facility **152**, powering up the receiver learn facility **152**, bringing the receiver learn facility **152** within a certain proximity of the receiver **130**, indicating on the remote **152** to begin the learn protocol, or the like. In an embodiment, the learn protocol may be fully automatic, semi-automatic with user intervention, manual, or the like. In an embodiment, a user may select a channel, frequency, or the like during learn protocol or after the learn protocol. The changing of the channel, frequency, or the like may prevent two different remote **148** and receiver **130** combinations from interfering with other wireless communication devices. In an embodiment, each time the learn protocol is executed, a new unique communication link may be established; there may be a plurality of unique communication links available for each remote **148** and receiver **130** combination.

[0129] In an embodiment, the remote **148** may be a user controlled device to provide control commands to the control box **134** to command certain functions of the adjustable bed facility **102**. In an embodiment, the certain functions may be adjustable bed facility section movement (e.g. up or down), vibration control, modular controlled **132** devices, or the like. In an embodiment, the remote **148** may communicate with the control box using wired communication, wireless communication, or the like. In an embodiment, the wireless communication may use a radio frequency (RF), infrared (IR), Bluetooth, or the like. If the remote communicates using a wireless technology, the communication may be with the receiver **130** and the receiver **130** may pass the command request to the control box **134**.

[0130] In an embodiment, the inputs of the remote control **148** may be organized into groups of common function control; the remote control **148** groups may be arranged in a circular orientation. As shown in FIG. 3, the remote control **148** may include more than one group **302** and may include at least one positioning control group and one vibration control group. In one embodiment, the remote control **148** groups **302** may be organized into a circular pattern where the circular pattern may provide for inputs that control increasing a function, decreasing a function, storing a function, global command functions **304**, or the like. For example, a circular group **302** may be divided up into a number of segments to control certain functions of the adjustable bed facility **102**. FIG. 3 shows four sections for each of the circular groups **302**, but it should be understood that there may be any number of sections to provide the required adjustable bed facility **102** control.

[0131] In one example, one of the circular groups **302** may be used to control movements of the adjustable bed facility **102** sections. The movement circular group **302** may have

inputs for moving the head section up/down, moving the foot section up/down, inputs for storing a user preferred positions to the PLC, or the like. Additionally, there may be a global command input **304** that may provide for commanding more than one adjustable bed facility **102** function using a single input such as commanding the adjustable bed facility **102** to go to a flat position. For example, the user may be able to select the flat button and the adjustable bed facility **102** may move all of the adjustable sections to the flat position.

[0132] A vibration circular group **302** may have inputs for controlling the vibration of the head section up/down, controlling the foot section vibration up/down, inputs for storing a user preferred vibration characteristics to the PLC, or the like. Additionally, there may be a global command input **304** that may provide for commanding more than one adjustable bed facility **102** vibration characteristic using a single input such as commanding the adjustable bed facility **102** to stop all vibration. For example, the user may be able to select the stop vibration input and the adjustable bed facility **102** may stop all of the adjustable sections from vibrating. In an embodiment, the user may select the all stop global **304** input to stop the adjustable bed facility **102** vibration before selecting a different vibration characteristic for one of the adjustable bed facility **102** sections.

[0133] In an embodiment, the user may be able to determine the control functions that the global command **304** may control. For example, the user may be able to input a command sequence to indicate the global command that should be applied to the global command **304** input. In an embodiment, the global command may be stored in the adjustable bed facility **102** memory **154** for later recall. In an embodiment, after the global command **304** has been stored, the user may select the global command **304** input for the command sequence execution.

[0134] The function of the remote **148** has been described with controlling adjustable bed facility **102** movement and vibration, but it should be understood that the remote may have control inputs for any function of the adjustable bed facility **102**. Additionally, the control inputs have been described as having a circular pattern, but it should be understood that other embodiments of the control input organization may be used for controlling the function of the adjustable bed facility **102**.

[0135] The remote **148** may include a timer that has a user defined setting that may allow the user to determine when the remote **148** communicates a control command to the adjustable bed facility. For example, the user may be able to set a timer on the remote **148** to indicate a time when the adjustable bed facility **102** is to go to a flat position. The user may use this function in the evening where the user may want to read for a half hour and then go to sleep, the user could set the timer for a half hour and the adjustable bed facility **102** may go to the flat position after the half hour. In another embodiment, the timer may be a clock where the user may be able to set a time when the adjustable bed facility **102** is to complete a certain function. In an embodiment, the user may be able to indicate the command that the remote **148** is to transmit to the adjustable bed facility **102** when the timer or clock setting indication has been reached.

[0136] In an embodiment, the remote **148** may be able to directly control the settings of external power outlets associated with the adjustable bed facility **148**. The power outlet may be an RF controlled power outlet and the remote **148** may be able to transmit an RF command directly to the RF power

outlet. In an embodiment, the power outlet may include settings of at least on, off, a percentage of power, or the like. The power outlet control power setting may be controlled by a hardware setting, a software setting, or the like. The power outlet may be an AC powered power outlet or a DC powered power outlet.

[0137] The remote 148 may include a timer that has a user defined setting that may allow the user to determine when the remote 148 communicates a control command to the RF power outlet. For example, the user may be able to set a timer on the remote 148 to indicate a time when the RF power outlet is to turn on or off. For example, the user may use this function in the evening where the user may want to read for a half hour and then go to sleep, the user could set the timer for a half hour to turn off a power outlet that controls a light fixture, after the half hour the remote 148 may command the RF power outlet to turn off and therefore turn the light fixture off. In another embodiment, the timer may be a clock where the user may be able to set a time when the RF power outlet may turn on or off. In an embodiment, the user may be able to indicate the command, such as on or off, that the remote 148 is to transmit to the RF power outlet when the timer or clock setting indication has been reached.

[0138] In an embodiment, the user may indicate adjustable bed facility 102 functions using the remote 148 by pressing a button, touching a screen, entering a code, speaking a command, or the like. In an embodiment, the control box 134, using the receiver 130, may receive and interpret the command provided by the remote 148. The remote may control devices with commands that may include on, off, high power, medium power, low power, volume, play, fast forward, rewind, skip, modular device to control, or the like. For example, the remote 148 may transmit a command to move the head section up and the control box 134 may command the actuator 104 to extend a certain amount in response to the command. In another example, the remote 148 may command that a modular control 132 connected lamp be turned off. The control box 134 may command the control box 132 to turn off the lamp.

[0139] Referring again to FIG. 1, in an embodiment, the control box 124 may use the bed memory 154 to store adjustable bed facility 102 settings, application software, demonstration software, and the like. In an embodiment, the user may determine that certain adjustable bed locations are preferred and should be saved for future recall. The control box 134 may save the user preferred settings in the bed memory 154 in order to recall the preferred settings at the use request. In an embodiment, the control box 134 may also store non-user requested information to the bed memory 154 as needed for the control of the various adjustable bed facility 102 components. For example, when the user requests an adjustable bed facility 102 section to move, the control box 134 may store the last position into bed memory 154 to be used as a last position recall, an undo command, the last settings for all the adjustable bed facility 102 component at shutdown, or the like.

[0140] In an embodiment, the control box 134 application software may be stored in the bed memory 154. In an embodiment, the software may be downloaded to the control box 134, may be run from the bed memory 154, or the like. In an embodiment, the application software may be an interrupt type application, a polling type application, or the like for sensing what command the user may have indicated on the remote 148. For example, in an interrupt application, each

command requested by the remote 148 may send an interrupt code to the control box 134. The control box 134 may then request from the application software the command sequence that is associated with the received interrupt. In another example, the polling application may continually poll the remote 148 for requested user commands and when a user command is detected, then request the command sequences for the requested user command.

[0141] In another embodiment, the control box 134 may use programmable logic circuits (PLC) to store application programs for control of the adjustable bed facility components. In an embodiment, the PLC may be part of the control box 134, part of a bed memory 154, in a separate control box, or the like. In an embodiment, the PLC may include a micro-computer, a microprocessor, volatile memory, non-volatile memory, IO connection to components, or the like. The PLC may provide an interface to permit software application updates to the PLC memory; PLC memory may be over written. In an embodiment, this may provide a method and system for providing software application upgrades to the adjustable bed facility 102.

[0142] In an embodiment, the PLC may have a connection to an external interface that may allow updates to be downloaded to the PLC. The connection may be a serial connection, a USB connection, a USB device, a parallel connection, a wireless connection, a bed memory 154, or the like. The capability to download information to the PLC may allow for software updates to the PLC, may allow for remote 148 interface updates to the PLC, may allow memory updates to the PLC, or the like. For example, if the user was supplied with a new or upgraded remote 148, the user may also be supplied with updated software for the PLC. The user may be able to connect the device containing the new software to the external interface and download the new software to the PLC.

[0143] In an embodiment, the PLC may have a connection interface with the modular controls 132 to provide the user with control over other devices that may be connected to the adjustable bed facility 102. The PLC may receive commands from the remote 148 for the modular controls 132 and may pass the command through to the modular control 132, may interpret the remote 148 command and command the modular control 132, or the like.

[0144] In an embodiment, the PLC may interface with a modular control 132 that is associated with external power outlets. In this embodiment, the user may be able to control the setting of the external power outlet by selecting a setting on the remote 148. The setting on the remote 148 may be received by the receiver 130 and PLC within the control box 134 to set the power outlet setting. For example, the user may be able to turn on the external power outlet by selecting an external outlet on input on the remote. This may result in the external outlet power being turned on to power an attached device such as a lamp.

[0145] In an embodiment, the bed memory 154 may be part of the PLC, external from the PLC, a combination of internal and external memory from the PLC, or the like.

[0146] In an embodiment, the bed memory 154 may be separate from the control box 134 and the PLC. In an embodiment, the bed memory 154 may be removable memory, the bed memory 154 may be moved from a first adjustable bed facility 102 to a second bed facility 102 to move user settings from the first adjustable bed facility 102 to the second bed facility 102. For example, a user in a care facility may be moved from a first adjustable bed facility 102 to a second

adjustable bed facility **102** but the user may have already determined and saved at least one preferred setting to the bed memory **154**. The bed memory may be removed from the first adjustable bed facility **102** and moved to the second adjustable bed facility **102** with the user and therefore the user may keep the same preferred adjustable bed **102** settings.

[0147] In this manner the bed memory **154** may be considered portable memory. In an embodiment, the removable bed memory **154** may be flash memory, programmable logic circuit (PLC), secure digital (SD) memory, mini SD memory, Compact Flash type I memory, Compact Flash type II memory, Memory Stick, Multimedia Card, xD Picture card, Smartmedia, eXtreme Digital, Microdrive, or the like.

[0148] In an embodiment, the bed memory **154** may be part of the remote **148**. As part of the communication between the remote **148**, receiver **130**, and control box **134** memory information may be exchanged between the remote **148** and control box **134**. For example, the user may indicate that a certain adjustable bed facility **102** position should be maintained for future recall. The control box **134** may receive the save position request from the remote **148** and transmit the position information back to the remote **148** for storage within the bed storage **154**. In a like manner, when the user requests the recall of a previously saved position, the control box **134** may request the position information from the remote **148** bed memory **154**.

[0149] In an embodiment, if the remote **148** is wireless, the remote **148** may contain both a transmitter and receiver, or a transceiver, to transmit and receive information with the control box **134**. In an embodiment, the remote **148** may communicate with the receiver **130** using a connection key. The connection key may be a code that indicates that a certain remote is associated with a certain adjustable bed facility **102**. When the remote **148** transmits information to the receiver, the remote may first send a key code to indicate that the remote **148** is associated with the adjustable bed facility **102**. If the key code matches the key that the receiver **130** is listening for, the receiver **130** may receive the command from the remote.

[0150] In an embodiment, the bed memory **154** may maintain the position information for the user preferred positions of the adjustable bed facility **102** sections. In an embodiment, the bed memory **154** may be implemented as a programmable logic circuit (PLC), a logic circuit (LC), or the like. FIG. 2 shows an embodiment of two methods of maintaining the user preferred positions in memory. In an embodiment, a first method may be to have discreet memory table **202** for each preferred user bed position **204**. There may be the same number of preferred bed positions **204** and memory locations **208** as indicators on the user remote **148**. For example, the remote may have two buttons for the user to set the preferred positions that may be used for later recall; the two buttons may be associated with two discreet memory locations **208**. In an embodiment, each time the user indicates a new preferred position for a button on the remote **148** the memory location **208** may be over written with the new position information. In an embodiment, this method may only allow the user to set one user preferred position for every button on the remote **148**.

[0151] In an embodiment, a second method of memory storage for user preferred adjustable bed positions may be a table **222** that may have a plurality of possible positions **212** the user may select. In an embodiment, as shown, the possible positions **212** may be P1 through Pn. In an embodiment, the

possible positions **212** may be a plurality of values that may define the range of available positions for the adjustable bed facility **102**; the plurality of values may be a set of values that define the range of available positions for one or more adjustable bed facility **102** functions. For example, the available positions **212** may be a set of increments of section positions that may include a set of actuator **104** positions, a set of actuator **104** activation times, bed section rotation angles, or the like. The set of increments may be determined from a base value for the section. For example, the increments may start at zero from the flat position for the adjustable bed facility **102** section. In an embodiment, the user may be able to select the increment set to be used as possible positions **212** for the section. For example, the user may be able to select the type of graduations by selecting from a set of possible graduation methods such as distance, angle of rotation, actuation time, or the like.

[0152] In FIG. 2, the table **222** is shown with an increment column **210** and an indication column **220**. In an embodiment, the table **222** may have a plurality of columns **220** to store position information for any of the adjustable aspects of the adjustable bed facility **102**. For example, there may be an indication column **220** for the head section angle, the foot angle section, the vibration characteristics for the various vibration motors of the adjustable bed facility **102**, or the like. In another embodiment, the adjustable aspects of the adjustable bed facility **102** may be represented by a plurality of individual tables **210** for storing indication information for each of the individual adjustable attributes for the adjustable bed facility **102**. The individual tables **210** may be substantially the same as the table **222** shown in FIG. 2 where there may be one column **210** for increments **212** and another column **220** for indication information (**214** and **218**). For example, there may be individual tables **210** for the head section angle, foot section angle, vibration motor characteristics, or the like. In an embodiment, the PLC may be able to access the adjustable bed facility **102** settings by accessing large tables **210** that contain many columns, small tables **210** that contain a few columns, a combination of large and small tables **210**, or the like.

[0153] In an embodiment, the PLC may store the tables **210** within the PLC memory for accessing the settings of the adjustable bed facility **102**. In another embodiment, the table **222** may be stored in memory outside of the PLC and the PLC may access the table **222** through an interface connection. The table **222** increment column **210** may represent a plurality of available positions associated with adjustable bed facility functions. In an embodiment, the increment values may be a measurement scale (e.g. inches or angle), may be the number of rotations of the actuator, the vibration frequency of the vibration motor, or other increment scale. In response to a user input, the indication column **220** may be marked with the indication **214** to represent the position intended by the user. When the user makes a request to save a position, the PLC may search the increment column **210** to determine which of the plurality of increments **212** represents the current position value of the adjustable bed facility **102** section. Once the current position value increment **212** within the table **222** is determined, an indication **214** may be stored to the indication column **220** associated to the current position value increment **212**. In an embodiment, the indication **214** may be any character that may represent a position being selected such as a letter, a number, special character, or the like. In embodiments, the indication column **220** may include all indications,

no indications, one indication, more than one indication, or the like to indicate the user's intended position. The storing of the indication association of the current position value with the user selected position may include adding a store indication to the table 222 entry representing the current position value, removing the current position value from the table 222 of values, removing a plurality of the table 222 values where the removal does not include removing the current position value, adding a store indication to every table 222 entry except a table 222 entry representing the current position value, or the like.

[0154] In an embodiment, when a user indicates on the remote 148 that a position is to be saved in the table 222, the PLC may select the increment value 212 from within the increment column 210 set of values that represents the current position of the adjustable bed facility 102. The PLC may store an indication 214 associated with the increment value 212; the stored indication associated with the current position value may be a recall value that may be recalled at a later time to reposition the adjustable bed facility 102.

[0155] In an embodiment, in response to the user requesting to return to a recall value, the PLC may scan the table 222 indication column 220 for an indication 214 that may represent the user's recall value. Upon locating the recall value indication 214, the PLC may command the adjustable bed function to the recall value indicated 214 location, position, vibration, or the like.

[0156] In an embodiment, the indication column 220 of the table 222 may initially contain indications 214 in all to the available discrete locations 212. As a user indicates that current position value is the position to be stored within the table 222, the indication 214 for the current position value may be removed from the table 222. This may result in one increment location 212 being empty of an indication. In this case, when a user requests to return to the recall position, the PLC may scan the table 222 indication column 220 for the empty increment location 212. Once the empty increment location is found, the PLC may command the adjustable bed function to the recall position, vibration, or other adjustable bed facility 102 function. In an embodiment, if the user stores a different current position value, the empty discrete location 212 may be filled with an indication and the new indication associated to the current position value may have the indication 214 removed. In an embodiment, the user may be able to clear the stored position by indicating a clear command and all of the increment locations 212 may be filled with indications 214.

[0157] In an embodiment, the available increment locations 212 in the indication column 220 of the table 222 may initially contain no indications 214 so that the indication column 220 may be empty. As a user indicates that a current position value is the position to be stored within the table 222, the indication 214 associated to the current position value may be added to the table 222. This may result in one increment location 212 having an indication. In this case, when a user requests to return to recall value position, the PLC may scan the table 222 indication column 220 for the increment location 212 containing the indication 214 associated with the recall value. Once the increment location is found, the PLC may command the adjustable bed function to the recall value position, position, vibration, or other adjustable bed facility 102 function. In an embodiment, if the user stores a different position, the increment location 212 indication 214 may be removed and the new current position value may have the indication 214 added. In an embodiment, the user may be able to clear the

stored position by indicating a clear command and all of the discrete locations 212 may have the indication 214 removed.

[0158] In an embodiment, when a user indicates a current position value is to be indicated in the table 222, the indication may represent the user's preferred adjustable bed facility 102 position. In an embodiment, the user's indicated current position value may be rounded to the closest table 222 increment location 214. For example, if the user selects a current position value that is between two increment positions on the table 222, an algorithm may be used to determine which of the increment positions are to be indicated in the indication column 220.

[0159] Embodiments of the present invention involve setting a recall bed position in response to a user making a storage selection. The user's storage selection may send a command to the adjustable bed facility's 102 controller (e.g. the PLC) indicating that the user would like the present position of the adjustable bed facility 102 stored such that the user can later have the adjustable bed facility 102 return to the stored position. The user may use a user interface (e.g. the remote control 148) and make such a storage selection once the adjustable bed facility 102 is in a desired position. As described herein elsewhere, a plurality of position values that define a range of available positions for the adjustable bed facility 102 may be stored in memory accessible by the adjustable bed facility's 102 controller. The available positions may be stored in a table 222 or other structure for example. Once the user initiates such a storage request, the controller may receive the request to save the current adjustable bed facility 102 position as a user selected position. The controller may then make a determination of which of the plurality of position values represent the current position of the adjustable bed facility 102 to provide a current position value. In determining which of the plurality of position values represents the current position, the controller may use an algorithm to decide which of the plurality of values best represents the current adjustable bed facility 102 position. For example, the actual adjustable bed facility 102 position may match one of the values and the algorithm may then select the matching value as the one that best represents the current position. In another situation, the actual adjustable bed facility 102 position may not match any of the plurality of values. In this case an algorithm may be used to determine which value best represents the position of the adjustable bed facility 102. The algorithm may run an averaging calculation, interpolation calculation or other form of prediction algorithm to select between two positions representing positions on either side of the actual adjustable bed facility 102 position, for example. Once the controller has made the determination as to which value represents the current adjustable bed facility 102 position, the controller may then store an association of the current position value with the user-selected position (e.g. as described elsewhere herein).

[0160] The embodiment of unmarking 218 preferred positions will be used in the following illustrations, but it should be understood that marking a current position value may also be used as a method of indicating a preferred position 212.

[0161] In an embodiment, the user may indicate the current position value by indicating a set position on the remote 148; this indication may result in all of the possible increment locations 212 having an indication 214 except for the one increment the user has selected which may be non-marked 218. For example, if the user selected the P3 position 212 as

a preferred position, all of the positions **212** may receive a mark **214** except the one position P3 which may receive a non-mark **218**.

[0162] In an embodiment, the positioning recall position logic of the adjustable bed may seek possible positions **212** that do not have a mark **218** when determining what user positions to select.

[0163] In an embodiment, the user may be able to set more than one increment position **212** in the table **222** for a single button on the remote **148**. For example, the user may be able to press a button on the remote **148** in a certain way to set a non-mark **218** at different preferred positions **212**. In another example, when the user presses a button on the remote **148**, the current position value may be unmarked **218** as a preferred position and an algorithm may be executed to unmark **218** other preferred positions **212** at certain increments from the user selected position. In one example of the algorithm, every 3rd position may be selected to be unmarked **218** as a preferred position **212**. The additional non-markings **218** may be by actuation time, section rotation angle, or the like. A person skilled in the art may understand that there may be any number of different methods of unmarking more than one position **212** using a single button on the remote **148**.

[0164] In an embodiment, with user preferred positions **212** unmarked **218** on the table **222**, the user may indicate on the remote **148** to recall the user preferred position **212**. In an embodiment, there may be an algorithm to search the table **222** for an unmarked **218** user preferred position **212** to position the bed to the recall value. Once the preferred position **212** is determined, the command logic may command the actuator or actuators to move the adjustable bed sections into the preferred position **212** recall value. In an embodiment, there may be more than one preferred position **212** unmarked **218** on the table **222**. In this case, the algorithm may seek the first unmarked **218** position **212** and move the adjustable bed section to that position. In an embodiment, if this is not the user desired position, the user may indicate again on the remote to recall a preferred position and the algorithm may seek the next unmarked **218** position **212**. A person skilled in the art may understand that there may be a number of different methods of recalling a plurality of marked **214** or unmarked **218** positions **212** from the table **222**.

[0165] Referring again to FIG. 1, in an embodiment, the removable bed memory **154** may be used to upgrade the adjustable bed facility **102** memory and software. For example, if new control box **134** software was developed to provide better control over one of the adjustable bed facility **102** components, the software may be saved to a new replaceable memory that may replace the existing replaceable memory. In this manner, the software of the adjustable bed facility **102** could be upgraded just by providing the user with a new replaceable memory.

[0166] In an embodiment, the removable memory may be used to provide a sales enterprise with adjustable bed facility **102** demonstration software where the enterprise may be able to indicate at least one of a plurality of demonstrations for a user. For example, the user may be interested in how the adjustable bed facility **102** sections may be adjusted and the enterprise may select a demonstration to show all the section motion available. In an embodiment, before an adjustable bed facility **102** is shipped to a user, the enterprise may remove the demonstration removable memory and replace it with a standard adjustable bed facility **102** bed memory **154**.

[0167] In an embodiment, the memory connection **160** may be any connection type that provides a connection between the bed memory **154**, control box **134**, and the like. In an embodiment, the memory connection **160** may be a wired or wireless connection. The wired connection may be a USB connection, a serial connection, parallel connection, or the like. The wireless connection may be by radio frequency (RF), infrared (IR), Bluetooth, or the like. In an embodiment, the memory connection **160** may be in a location that is easy for the user to access the bed memory **154**, may be attached to the memory facility **150**, may be attached to the control box **134**, or the like. In an embodiment, the easy access memory connection may be on the side of the adjustable bed facility **102**, on a rail of the adjustable bed facility **102**, under the adjustable bed facility **102**, or the like.

[0168] In an embodiment, the control box **134** may also access a network using a network connection **162**. In an embodiment, the network may be a LAN, WAN, Internet, intranet, peer-to-peer, or other network with computer devices that the control box **134** may communicate with. In an embodiment, the network connection **162** may be a wired or wireless connection.

[0169] In an embodiment, using the network connection **162**, the control box **134** may be able to communicate with the network to periodically check for application software updates. In an embodiment, if an application software update is located, the control box **134** may send the user an email, instant messenger message, phone message, phone call, cell phone message, cell phone call, fax, pager message, or the like to indicate that software updates are available. The user, using the device that received the notice of software update, may send a reply to the control box that the software upgrade should be downloaded, should not be downloaded, or the like.

[0170] In an embodiment, an adjustable bed facility **102** enterprise, an adjustable bed facility **102** manufacturer, an adjustable bed facility **102** service enterprise, or the like may send the control box **134** software updates using the network connection **162**. In an embodiment, an adjustable bed facility **102** enterprise, an adjustable bed facility **102** manufacturer, an adjustable bed facility **102** service enterprise, or the like may notify the user of available software upgrades for the adjustable bed facility **102** by email, instant messenger message, phone message, phone call, cell phone message, cell phone call, fax, pager message, or the like. The user, using the device that received the notice of software upgrade, may send a reply to the adjustable bed facility **102** enterprise, the adjustable bed facility **102** manufacturer, the adjustable bed facility **102** service enterprise, or the like that the software upgrade should be downloaded, should not be downloaded, or the like.

[0171] In an embodiment, the user may access the network connection **162** with the user's own computer device.

[0172] In an embodiment, the remote **148** and control box **134** may be able to control other devices that may be connected to modular controls **132**. In an embodiment, the modular controls **132** may be similar to the control box by interpreting commands to control a device, but may be unique to the device that is connected to it. In an embodiment, the modular controls **132** may control audio equipment, video equipment, lamps, air purification facilities, outlets, and the like. For example, the modular control **132** may be connected to audio equipment and may contain the command sequences to control the audio equipment based on commands that may be received from the remote **148**. It may be obvious to some-

one in the art that any of the devices that are connected to modular controls **132** may be controlled in the same manner.

[0173] In an embodiment, the user may indicate a function to be accessed for a certain device connected to a modular control **132**, the control box **134** may receive the request from the remote **148** and pass the command onto the appropriate modular control **132**. In an embodiment, the remote **148** may have modular control **132** device functions that the user may select to control a modular control **132** device. For example, the remote **148** may have functions such as play, fast-forward, rewind, skip, pause, and the like for an audio device connected to the modular control **132**.

[0174] In an embodiment, the modular controls **132** may be connected to the control box **134** and power supply **140** using a wire harness **128**. The wire harness **128** may contain power and data connections for all of the possible connection locations for the modular controls **132**. For example, if there are six locations on the adjustable bed facility **102** for attaching modular controls **132**, the wire harness **128** may have six sets of power and data connections available.

[0175] In another embodiment, the wire harness may provide only power to the modular controls **132** and the communication between the modular controls **132** and control box **134** may be wireless that may include radio frequency (RF), infrared (IR), Bluetooth, and the like.

[0176] In an embodiment, using the remote **148**, the control box **134** may be able to control power outlets **138** to which external devices may be connected; the power outlets may be associated with the adjustable bed facility **102**, remote from the adjustable bed facility **102**, or the like. In an embodiment, the control box may communicate with the power outlet using wired or wireless communications. In this embodiment, the power outlets **138** may receive power directly from a household outlet, fuse box, circuit box, or the like but the function of the power outlets **138** (e.g. on or off) may be controlled by the control box **134**. For example, an external lamp may be connected to the power outlets **138**, there may be a selectable control on the remote **148** for the user to turn the power outlet **138** on and off and therefore to turn the lamp on and off. In an embodiment, the power outlets **138** may include a control circuit that is able to control if the power outlet **138** receives power from the household current. In an embodiment, there may be more than one power outlet controlled by the control box **134** and there may be a selection for each of the power outlets **138** on the remote **148**.

[0177] In an embodiment, the power outlets **138** may be directly controlled by the remote control **148** using radio frequency (RF). The remote control and power outlets may be RF capable for communication within the adjustable bed facility **102**. The remote control **148** may be able to directly control the power outlets **138** to turn the power outlets on and off using RF without interfacing with the control box **134**.

[0178] In an embodiment, the control box **134** may be able to control an external air purification **144** facility; the air purification **144** facility may be directly controlled by the control box using a wired or wireless connection. In an embodiment, the wireless connection may be radio frequency (RF), infrared (IR), Bluetooth, or the like. In an embodiment, the air purification facility **144** may be any type of device or facility that may be capable of improving that air environment in the area of the adjustable bed facility **102**. In an embodiment, the air purification facility **144** may be an absorbent type (e.g. carbon), electro-static, HEPA filter, or the like. In an embodiment, absorbent materials may be used in a filter, in

the adjustable bed facility **102**, in the mattress **110**, or the like to absorb odor, dust, contaminants, or the like from the air environment around the bed, within the bed, or the like. In an embodiment, electro-static or ionic air filters may use negative ions to attract dust, contaminants, and the like from the air. In an embodiment, electro-static materials (e.g. tourmaline) may be used in a filter, in the adjustable bed facility **102**, in the mattress **110**, or the like to absorb odor, dust, contaminants, or the like from the air environment around the bed, within the bed, or the like. In an embodiment, HEPA filters are composed of a mat of randomly arranged fibers that are designed to trap at least 99.97% of dust, pollen, mold, bacteria, and any airborne particles with a size of 0.3 micrometers (μm) at 85 liters per minute (Lpm). The HEPA filter may be used in a device, facility, or the like for filtering the air in the area of the adjustable bed facility **102**.

[0179] In an embodiment, the air purification facility **144** may be part of the adjustable bed facility **102**, a freestanding device or facility, or the like. In an embodiment, if the air purification facility **144** is part of the adjustable bed facility **102** the air purification facility **144** may be attached to any part of the adjustable bed facility **102** such as the mattress **110**, sub-frame **112**, skeleton structure **114**, or the like. In an embodiment, the air purification facility **144** that is attached to the adjustable bed facility **102** may be controlled direct control of the air purification facility **144** device, control using the remote **148**, or the like.

[0180] In an embodiment, the air purification facility **144** may be a free standing device that may be plugged into a adjustable bed facility **102** power outlet **138** and therefore may be controlled with the remote **148** controlling the on/off condition of the power outlet **138**.

[0181] In an embodiment, the air purification facility **144** may be a freestanding device that may be connected to an adjustable bed facility **102** modular control **128**. The modular control may provide power (AC or DC), control communication, and the like to the air purification facility **114**. In an embodiment, the user may be able to control the air purification facility **144** using the remote **148** to control the modular controls **132**.

[0182] In an embodiment, an adjustable bed facility **102** may be any bed that is capable of adjusting at least one aspect of the bed such as a head section, a foot section, a leg section, a torso section, or the like. In an embodiment, the adjustment may include moving the sections up, down, higher, lower, longer, shorter, and the like. In an embodiment, the section adjustments may also include vibration, massage, and the like. In an embodiment, the adjustable bed facility **102** may include components such as actuators **104**, springs **108**, a mattress **110**, a sub-frame **112**, a skeleton structure **114**, vibration motors **118**, supports **120**, safety brackets **122**, wire harness **128**, receiver **130** modular controls **132**, control box **134**, power outlets **138**, power supply **140**, power connection **142**, air purification facility **144**, remote control **148**, receiver learn facility **152**, bed memory **154**, backup battery **158**, memory connection **160**, network connection **162**, and the like.

[0183] In an embodiment, the adjustable bed facility **102** sections may be adjustable by a user, a care giver, a medical person, or the like to provide a comfortable position, a medical required position, a working position, a resting position, or the like. For example, a medical position may be required to have a user's legs elevated to aid in the reduction of swelling and therefore the leg or foot sections may be elevated. In

another example, a user with a back condition may need to rest his or her back and may still wish to work, the user may be able to position the adjustable bed facility **102** to provide a comfortable back position that allows the user to work on papers or a computer device.

[0184] In an embodiment, the adjustable bed facility **102** may be used in a home, a hospital, a long-term care facility, or the like. The adjustable bed facility **102** may be used by users that may have limited mobility, are restricted to bed rest, require a non-flat sleeping position, and the like.

[0185] In an embodiment, actuators **104** may be used to move the adjustable bed facility **102** sections. The actuator **104** may typically be a cylinder device where a first component, under a force, is extendable from second component that may result in the action of moving an object. In an embodiment, there may be more than one actuator **104** per adjustable bed facility **102**. There may be an actuator **104** to move any of the adjustable bed facility **102** sections or other aspects of the adjustable bed facility **102**. For example, there may be individual actuators for the head section, leg section, foot section, torso section, or the like. In an embodiment, a single actuator may be used to move more than one adjustable bed facility **102** section. For example, one actuator may be used to move the leg and foot sections; the leg and foot sections may be connected by a mechanical structure that may control the orientation of the leg and foot sections during movement. In an embodiment, the actuators **104** may be connected between the adjustable bed facility **102** section to be moved and the sub-frame **112**, skeleton structure **114**, or the like.

[0186] In an embodiment, the actuator **104** may have different driving means to extend and retract the actuator **104** such as an electric motor, pneumatic pressure, hydraulic pressure, or the like.

[0187] In an embodiment, the electric motor driven actuator **104** may use a DC or AC motor and gear assembly to extend and retract the actuator **104**.

[0188] In an embodiment, the pneumatic pressure actuator **104** may use an air source to extend and retract the actuator **104**. The air source may be part of the pneumatic actuator **104**, may be a separate device, or the like. In an embodiment, the separate air source device may be part of the adjustable bed facility **102** or may be external to the adjustable bed facility **102**.

[0189] In an embodiment, the hydraulic pressure actuator **104** may use a fluid source to extend and retract the actuator **104**. The fluid source may be part of the hydraulic actuator **104**, may be a separate device, or the like. In an embodiment, the separate fluid source device may be part of the adjustable bed facility **102** or may be external to the adjustable bed facility **102**.

[0190] In an embodiment, springs **108** may be used with a mattress **110**, instead of a mattress **110**, or the like. In an embodiment, the springs may be a standard bed spring system (e.g. coils within a wire framework), individual coil springs, individual foam springs, air springs, or the like. In an embodiment, the individual springs (e.g. coil, foam, or air) may be used to provide variable firmness to provide comfort to the user. For example, the springs **108** may be less firm or firmer in a local area to provide the user with the support that may be required for a body location that is experiencing discomfort (e.g. a hip, shoulder, back, neck).

[0191] In an embodiment, the mattress **110** may include foam, feathers, springs **108**, material, or the like. In an embodiment the different materials may be used individually

or in combination. The mattress may be intended to provide the user with a firmness that provides for the comfort requirements of the user.

[0192] In an embodiment, the mattress **110** may be an air mattress. In an embodiment, the air mattress may be constructed using a single chamber, a plurality of chambers, a plurality of individual chambers, a combination of chamber shapes, or the like. In an embodiment, the air mattress **110** may be inflated to various pressures that may provide the user with the desired comfort level. In an embodiment, there may be separate air mattresses **110** for each of the adjustable bed facility **102** sections. For example, there may be separate air mattresses **110** for the head, torso, and foot sections of the adjustable bed facility **102**. In an embodiment, the inflation pressure of the individual air mattresses **110** may be different from each other depending on user settings.

[0193] In another embodiment of an air mattress **110** with individual chambers, local firmness control may provide local firmness comfort to a user to provide comfort. For example, a user may be recovering from surgery and may require the air mattress **110** to be less firm in a certain area, the user may be able to indicate the area to be less firm and the individual chamber pressures may be adjusted to provide the less firm area. Additionally, while a local area may be provided with a less firm pressures, the remainder of the mattress **110** may have a consistent firmness pressure.

[0194] In an embodiment, the sub-frame **112** may be a structural support frame in contact with the floor and may include the floor legs, connections for the actuators **104**, connections for the supports **120**, support for the skeleton structure **114**, and the like. In an embodiment, the sub-frame **112** materials may include wood, metal, plastic, and the like. In an embodiment, the sub-frame **112** may provide a support interface to the skeleton structure **114** and may support the freedom of motion for the skeleton structure **114**. For example, the sub-frame **112** may include an interface such as a track, surface, groove, slot, or the like in which the skeleton structure **114** may interface and use as a guide while providing motion support for the various adjustable bed facility **102** sections. In an embodiment, the sub-frame **112** interface may be a "C" channel in which the skeleton structure **114** may have interfacing wheels to move within the "C" channel during the adjustable bed facility **102** section movements.

[0195] In an embodiment, the sub-frame **112** may be substantially the same shape as the adjustable bed facility **102** and may have structural members along the length and width of the sub-frame **112**. In an embodiment, the structural members may be assembled in any configuration that meets the requirements of supporting the adjustable bed facility **102** and the various devices such as the actuators **104**, supports **120**, skeleton structure **114**, and the like.

[0196] In an embodiment, the skeleton structure **114** may be a mechanical structure that may provide support to the springs **108**, provide support to the mattress **110**, interface with the sub-frame **112**, provide a connection to the actuators **104**, provide a connection to the supports **120**, support the vibration motors **118**, and the like. In an embodiment, there may be more than one skeleton structure **114** within the adjustable bed facility **102**; there may be a skeleton structure **114** for each adjustable bed facility **102** section. For example, there may be a skeleton structure **114** for the head section, foot section, leg section, torso section, and the like.

[0197] In an embodiment, the skeleton structure **114** may be a frame type structure to support at least one mattress **110**,

provide connectivity between more than one mattress **110**, contain a hinge mechanism to allow the motion of a first mattress **110** in relation to a second mattress **110**, and the like. The frame structure may be substantially the same shape as the mattress **110** that the skeleton structure **114** is supporting and may have individual structure members at the peripheral edges of the mattress **110** in addition to other individual structural members that may be required for support of mechanical connections, support of the mattress **110**, or the like. In an embodiment, the skeleton structure **114** may include materials such as metal, wood, plastic, and the like. The skeleton structure **114** materials may be used individually or in combination.

[0198] In an embodiment, the skeleton structure **114** may have an interface facility such as wheels, slides, skids, rails, pivot points, and the like that may interface with the sub-frame **112** support interface. The skeleton structure **114** interface facility may provide for smooth interaction with the sub-frame **112** support interface when the skeleton structure **114** is in motion as a result of actuation from the actuators **104**.

[0199] In an embodiment, a vibration facility **118** may provide vibration input to the adjustable bed facility **102** sections such as the head section, foot section, leg section, torso section, and the like; there may be vibration facilities in any or all of the adjustable bed facility **102** sections. In an embodiment, the vibration facilities **118** may be operated independently, at the same time, at alternate times, in coordination, or the like. For example, the vibration facilities in the head section and foot section may be operated at the same time to provide a full body massage or the vibration frequencies may operate at alternating times to provide a wave effect of the vibration moving from the head to foot of the adjustable bed facility **102**. In another example, the different vibration facilities **118** may be used in concert where the vibration facilities **118** may be vibrated in sequences to create a massaging effect. It may be understood by one knowledgeable in the art that different effects may be created with more than one vibration facility **118**.

[0200] In an embodiment, using the remote **148**, the user may be able to control the vibration mode of the various vibration motors **118**; the mode may include the vibration setting for a particular bed section, the vibration frequency of at least one of the vibration motors **118**, stopping the vibration of at least one of the vibration motors, or the like. The remote **148** may provide vibration motor **118** control information to the adjustable bed facility **102** control box **134** for control of the vibration characteristics of the adjustable bed facility **102**. In an embodiment, the remote **148** may include user inputs that include at least one of head vibration increase, head vibration decrease, foot vibration increase, foot vibration decrease, user preferred vibration settings, vibration stop, or the like.

[0201] In an embodiment, the vibration motor **118** may be capable of a plurality of vibration frequencies. For example, the vibration motor **118** may be able to operate on frequencies such as high, medium, low, settings 1-10, or the like. In an embodiment, a first vibration frequency may be stopped before a second vibration frequency is started. In embodiments, the stopping between the first vibration and the second vibration may be automatic and controlled by the logic within the control box **134**, may be manually indicated by the user using the remote **148**, or the like. As an example of manual input, the vibration motor **118** may be operating on a medium

frequency and the user may provide a stop vibration input on the remote **148** to stop the first vibration motor **118** vibration before pressing the low vibration frequency input.

[0202] Referring to FIG. 5A and FIG. 5B, an embodiment of a vibration motor **118** is shown within an opening of an adjustable bed facility **102** support lateral surface **508**. The adjustable bed facility **102** section may have a lateral surface **508** and the lateral surface **508** may include an opening in which the vibration motor **118** may be located; the vibration motor **118** may fit within the opening such that the vibration motor **118** may not contact the lateral surface **508**. In an embodiment, the vibration motor **118** may be secured to the adjustable bed facility **102** section using at least one bracket **504**. In an embodiment, when more than one bracket **504** is used, at least one of the brackets **504** may be separable and removable. In an embodiment, the at least one bracket **504** may be shaped to secure the vibration motor **118** within the section opening such as a straight bracket, a U shaped bracket, an L shaped bracket, or the like; in FIG. 5A and FIG. 5B the bracket **504** is shown as a straight bracket **504**. In an embodiment, the removal of one of the brackets **504** may facilitate securing the vibration motor **118** to the bed section, facilitating the servicing of the vibration motor **118**, or the like. The bracket **504** may be positioned such that at least one portion of the bracket **504** is within the opening of the lateral surface **508** and may also be positioned such that the bracket **504** may overlap the vibration motor **118** flange. The vibration motor **118** flange may extend beyond the perimeter of the opening of the mattress support and the resilient material **502** may provide positional support for the vibration motor **118** so that the flange imparts vibration to the mattress **110** without contacting the mattress support. The at least one bracket **504** may be coupled to the mattress support **508** using a removable coupling. Removing the at least one bracket may facilitate removing and servicing the motor. The resilient material **502** may provide mechanical insulation between the flange and the perimeter of the opening in the mattress support **508**. The resilient material **502** disposed between the flange and the lateral support **508** surface of the at least one bracket **504** may further provide positional support for the vibration motor **118** housing. The bracket **504** may be constructed using material such as plastic, metal or the like and may be constructed using the materials individually or in combination. In an embodiment, there may be a resilient material **502** associated with the brackets **504**, the resilient material may provide for dampening the vibration between the vibration motor **118** and the adjustable bed facility **102**, may contact the vibration motor **118** to secure the vibration motor **118** to the bed section, may provide for dampening of vibration to the adjustable bed facility **102** and hold the vibration motor **118** in place, or the like. The resilient material **502** may include latex foam, polyurethane foam, polypropylene foam, polyethylene foam, or the like and may be used individually or in combination.

[0203] In an embodiment, the vibration facility **118** may be connected to the skeleton structure **114**, the mattress **110**, the lateral surface **508**, or the like where the vibration may be imparted into the adjustable bed facility **102** mattress **110** as desired by the user. In an embodiment, the vibration motor **118** flange may provide surface area that may impart a vibration into the mattress **110**. In an embodiment, the vibration motor **118** may be secured to the adjustable bed facility **102** section using two separable brackets; at least one of the two separable brackets may be removable. In an embodiment, the removal of one of the brackets may facilitate securing the

vibration motor **118** to the bed section, facilitating the servicing of the vibration motor **118**, or the like. The bracket may be constructed using a material such as plastic, metal, or the like and may be constructed using the materials individually or in combination. In an embodiment, there may be a resilient material attached to the brackets, the resilient material may provide for a dampening the vibration between the vibration motor **118** and the adjustable bed facility **102**, may contact the vibration motor **118** to secure the vibration motor **118** to the bed section, or the like. For example, the brackets may be attached to the adjustable bed facility **102** section with the resilient material making contact with the vibration motor **118** that may be in an opening of the section. The resilient material may provide the force required to hold the vibration motor in place within the section opening and may provide dampening of the vibration to the adjustable bed facility. The resilient material may include latex foam, polyurethane foam, polypropylene foam, polyethylene foam, or the like and may be used individually or in combination.

[0204] In an embodiment, the electric motor vibration facility **118** may use DC or AC current to power the motor. In an embodiment, to provide the vibration, the motor may rotate an offset mass on the motor shaft that may cause the vibration facility **118**, mattress **110**, skeleton structure **114**, or the like to vibrate. The user may feel the vibration through the mattress **110**, springs **108**, or the like.

[0205] In an embodiment, an air bladder or air spring may be used to provide a vibration to the adjustable bed facility **102**. In an embodiment, the air bladder or air spring air pressure may be varied at a frequency to create a vibration within the vibration facility **118**, mattress **110**, skeleton structure **114**, or the like. In an embodiment, there may be an air supply unit that supplies the frequency varied air pressure to the air bladder or air spring.

[0206] In an embodiment, the vibration motor **118** may be in proximity to a vibration distribution facility that may aid in the propagation of vibration energy to the adjustable bed facility **102** section. In an embodiment, the vibration motor **118** may be operatively connected to the vibration distribution facility, may be in contact with the vibration distribution facility, may not be in contact with the vibration distribution facility, or the like. In an embodiment, the vibration distribution facility may provide for a more uniform distribution of the vibration characteristics of the vibration motor **118** and may have a size and shape relative to the size and shape of the adjustable bed facility **102** section. The vibration distribution facility may be constructed using materials such as plastic, rubber, metal, or the like and may be constructed using these materials individually or in combination. In an embodiment, the user may be able to control the speed, amplitude, pulse, and the like of the vibration facility **118** using an interface such as the remote **148**.

[0207] In an embodiment, the vibrator facility **118** may be mounted to the mattress **110** using the vibration distribution facility, resilient material **502**, strong fabric, or the like. In an embodiment, each adjustable bed facility **102** section that includes a vibrator facility **118** may have an opening in the section to accept the vibrator facility **118**. In an embodiment, over the opening in the section, a layer of resilient material **502**, strong fabric, or the like may be placed. The layer of resilient material **502**, strong fabric, or the like may be placed between the vibrator facility **118** and the mattress **110**. In an embodiment, the vibrator facility **118** may impart vibrations to a mattress **110** through the resilient material **502** disposed

over an opening in an adjustable bed facility **102** section. In an embodiment, a fabric cover may be disposed over the resilient material **502** and/or an adjustable bed facility **102** section, between the vibrator facility **118** and the mattress **110**. In embodiments, a plurality of fabric covers may be disposed over the resilient material **502** and/or an adjustable bed facility **102** section to provide stabilization. In an embodiment, the vibrator facility **118** may impart vibrations to a mattress **110** through a resilient material **502** and a fabric or plurality of fabrics covering the resilient material **502** and/or adjustable bed facility **102** section.

[0208] In an embodiment, the resilient material **502** may be foam, cotton matting, or the like. In an embodiment, the vibration distribution facility may be plastic, wood, rubber, metal, or the like and may be any size and/or shape that supports the required vibration characteristics. The vibration distribution facility may have a plurality of barbs or other anchoring devices that may be pushed into the resilient material, strong fabric, or the like to secure the vibration distribution facility in place on top of the resilient material, strong fabric, or the like. In an embodiment, the barbs or other anchoring devices may have a number of gripping edges, points, or the like to provide a connection with the resilient material and strong fabric.

[0209] In an embodiment, the vibrator facility **118** may be mounted to the vibration distribution facility through the opening of the adjustable bed facility **102** section lateral surface **508**. In an embodiment, the vibration motor **118** may be operatively connected to the vibration distribution facility, may be in contact with the vibration distribution facility, may not be in contact with the vibration distribution facility, or the like. In an embodiment, there may be a layer of resilient material, strong fabric, or the like between the vibrator motor **118** and the vibration distribution facility.

[0210] In an embodiment, any space between the vibration facility **118** and the opening of the adjustable bed facility **102** section may be filled with a vibration absorbent material such as foam, cotton matting, rubber, or the like. The absorbent material may provide a layer of vibration insulation between the vibration facility **118** and the adjustable bed facility **102** section opening.

[0211] In an embodiment, the combination of the vibration distribution facility and vibration facility **118** may be a vibration facility assembly. In an embodiment, the vibration facility **118** assembly may be attached to the adjustable bed facility **118** sections with the plurality of barbs or anchoring devices.

[0212] Referring again to FIG. 1, in an embodiment, the supports **120** may be hydraulic pressurized cylinders that may provide additional control of the decent of the adjustable bed facility **102** sections. The pressurized supports **120** may be designed to support a certain amount of weight that may include the skeleton structure **114**, mattress **110**, springs **108**, user, and the like. In an embodiment, the pressurized cylinders may be similar to the type of supports that are used in automobile trunks to support the trunk open while the user access the trunk area.

[0213] In an embodiment, the supports **120** may provide a safety feature when combined with the safety bracket **112**. The safety bracket **122** may prevent the actuators from forcibly pulling the adjustable bed facility **102** sections down; the safety bracket is described in more detail below. The supports **120** may be positioned on the sections that are actuated and may provide a controlled speed at which the sections will

return to a horizontal position. In an embodiment, the support **120** may provide support of a weight that is less than the weight of the section, therefore the section will provide enough force (e.g. weight) on the support **120** to compress the cylinder and move the section down. In an embodiment, there may be more than one support **120** for each actuated adjustable bed facility **102** section. In an embodiment, the support **120** may be connected between the skeleton structure **114** and the sub-frame **112**.

[0214] In an embodiment, the safety bracket **122** may be a slotted bracket that provides the connection between the actuators **104** and the skeleton structure **114** for the purpose of moving the adjustable bed facility **102** sections. A side of the slot that is farthest from the actuator **104** may be the slot first side and may be the side that the actuator **104** pushes on to move the adjustable bed **102** section up. A side of the slot that is nearest to the actuator **104** may be the slot second side and may be the side the actuator **104** pulls on to move the adjustable bed **102** section down. In an embodiment, when the actuator **104** is expanding and moving an adjustable bed facility **102** section it may apply a force on the first side of the slot and move the section in an upward direction. When the actuator **104** is retracted to move the section in a downward direction, the actuator **104** connection may move into the middle area (e.g. not in contact with the first or second side of the slot) of the safety bracket **122** slot. As the actuator **104** connection moves into the slot middle area, the adjustable bed facility **102** section may move in a downward motion under the force of section weight. In an embodiment, the actuator **104** may retract at the same speed as the safety bracket **122** moves, therefore the actuator **104** connection may stay in the safety bracket **122** slot middle area and not make contact with the second side of the safety bracket **122** slot. In this manner, the actuator **104** connection may not contact the second side of the slot and therefore the adjustable bed **102** section may not move in the downward direction by the force of the actuator **104**.

[0215] In an embodiment, if the actuator **104** connection comes in contact with the second side of the safety bracket **122** slot, there may be a shutoff switch, shutoff indicator, or the like that may stop the retraction of the actuator **104**.

[0216] In an embodiment, the adjustable bed facility **102** may include an electronic facility **124**. In an embodiment, the electronic facility **124** may include a wire harness **128**, a receiver **130**, power outlets **138**, modular controls **132**, a power supply **140**, a power connection **142**, and the like. In an embodiment, different components of the electronic facility **124** may be individual components, combined components, individual and combined components, or the like. For example, the receiver **130**, control box **134**, and power supplied may be individual components, may be combined into a single component, may be a combination of individual and combined components, or the like. In an embodiment, the various electronic facility **124** components may be mounted on the sub-frame **112**, skeleton structure **114**, or the like as required for the particular component.

[0217] In an embodiment, the wire harness **128** may provide power and data connections to a plurality of modular controls **132**. Depending on the power supply **140**, the wire harness may provide either DC or AC power to the modular controls **132**. In an embodiment, the data connections may be serial, parallel, or the like. In an embodiment, the wire harness may have the same number of power/data connections as there are possible modular controls **132**. In an embodiment,

the wire harness may be a unit of power/data connections that may be bound together into a single wire harness. In another embodiment, the wire harness may be a group of individual power/data connections. In an embodiment, for each individual wire in the bundle, group, or the like, a first end may have connections for the control box **134** and power supply **140**. A second end of the wire harness **128** may be a power and data connection for each individual modular control **132**.

[0218] In an embodiment, a receiver **130** may receive user commands from a remote control **148**. In an embodiment, the receiver **130** may have a wireless or wired connection to the remote **148**. In an embodiment, the wireless remote **148** to receiver **130** communication may be a radio frequency (RF) communication, infrared (IR) communication, Bluetooth communication, or the like. In an embodiment, the receiver **130** may receive the communication command from the remote **148** and transmit the remote **148** command to the control box **134**. The communication with the control box **134** may be wireless or wired. In an embodiment, the wireless communication between the receiver **130** and the control box **134** may be a radio frequency (RF) communication, infrared (IR) communication, Bluetooth communication, or the like. In an embodiment, the receiver **130** may be combined with the control box **134** into a single component. In an embodiment, the skeleton structure **114** may be used as an RF antenna for receiving communication from the remote **148** to the receiver **130**. In embodiment, the entire skeleton structure **114** may be used as an antenna, a portion of the skeleton structure **114** may be used as an antenna, or the like.

[0219] In an embodiment, the modular controls **132** may provide additional functionality to the adjustable bed facility **102** that may include a stereo, a CD player, an MP3 player, a DVD player, a lamp, power outlets **138**, an air purification facility **144**, or the like. The additional functionality that the modular controls **132** provide may be considered optional equipment that may be offered with the adjustable bed facility **102**. For example, a user may be able to purchase an adjustable bed facility **102** without any modular controls **132** and may add modular controls as he or she desires. In another example, the user may purchase the adjustable bed facility **102** with modular controls already installed. In an embodiment, the modular controls **132** may have predetermined mounting locations on the sub-frame **112**, skeleton structure **114**, or the like.

[0220] In an embodiment, the modular controls **132** may directly control devices, indirectly control devices, or the like. For example, the modular control **132** may directly control a lamp that is connected to the modular control **132** but may indirectly control a device or facility that is plugged into an outlet **138** controlled by the modular control **132**. The devices and facilities may include a stereo, CD player, DVD player, air purification facilities, or the like may receive power from power outlets **138** that are controlled by the modular control **132**. In this example, the user control of the power outlet **138** to turn the device on or off but the user may not be able to control the individual device (e.g. the volume of stereo). In an embodiment, the user may control the additional function devices by using the remote **148** that may have an interface for each of the modular controls **132**. For example, there may be an interface on the remote **148** for turning on a lamp, turning off a lamp, dimming a lamp, and the like. In a similar manner, the user may be able to control if a power outlet **138** provided by a modular control **132** is on or off.

[0221] In an embodiment, the modular controls 132 may be connected to the control box 134, power supply 140, or the like; the connection may be the wire harness 128. In an embodiment, the modular controls 132 may communicate with the control box 134 by a wireless means that may include radio frequency (RF), infrared (IR), Bluetooth, or other wireless communication type.

[0222] In an embodiment, the control box 134 may interpret commands received from the receiver 130 into commands for the various adjustable bed facility 102 components such as the actuators 104, the vibration facility 118, the modular controls 132, power outlets 138, and the like. In an embodiment, the control box 134 may contain a microprocessor, microcontroller, or the like to run a software application to interpret the commands received from the remote 148 through the receiver 130. In an embodiment, the software application may be interrupt based, polling based, or other application method for determining when a user has selected a command on the remote 148. In an embodiment, the software application may be stored in the control box 134, stored in bed memory 154, or the like and may be stored as software, as firmware, as hardware, or the like.

[0223] In an embodiment, the control box 134 may receive information from the receiver 130 by wired communication, wireless communication, or the like. In an embodiment, the wireless communication may be by radio frequency (RF), infrared (IR), Bluetooth, or other wireless communication type.

[0224] In an embodiment, after the control box 134 has interpreted the received user commands, the control box 134 may transmit the interpreted commands to the various controllers for the adjustable bed facility 102 components such as the actuators 104, vibrator facility 118, modular controls 132, power outlets 138, and the like. The control box 134 may transmit information that may be further interpreted by the components into commands for the individual components. For example, the control box 134 may receive a command to move the head section up. The control box 134 may interpret the remote 148 command into a command the actuator may understand and may transmit the command to extend the head section actuator to move the head section up.

[0225] In an embodiment, the power supply 140 may receive power from a standard wall outlet, fuse box, circuit box, or the like and may provide power to all the powered components of the adjustable bed facility 102. In an embodiment, the power supply 140 may provide DC power or AC power to the components. In an embodiment, if the power supply 140 provides DC power, the power supply 140 may convert the incoming AC power into DC power for the adjustable bed facility 102.

[0226] In an embodiment, the power outlets 138 may provide standard household AC current using a standard outlet for use by external devices using a standard plug. In an embodiment, the power outlets 138 may receive power directly from a standard wall outlet, a fuse box, a circuit box, or the like, but the control box 134 may control whether the power outlet 138 on or off. In an embodiment, the power outlet 138 may have a control circuit that may determine if the power outlet 138 is active (on) or inactive (off). In an embodiment, the command to indicate if the power outlet 138 is active or inactive may be received from the control box 134. In an embodiment, the control box 134 may receive commands for the power outlet 138 control from the remote 148.

[0227] In an embodiment, the power connection 142 may receive standard power for the adjustable bed facility 102 from a standard outlet, fuse box, circuit box, or the like. In an embodiment, the power connection 142 may provide standard AC power to the power outlets 138, the power supply 140, or the like.

[0228] In an embodiment, the air purification facility 144 may be any type of device or facility that may be capable of improving that air environment in the area of the adjustable bed facility 102. In an embodiment, the air purification facility 144 may be an absorbent type (e.g. carbon), electro-static, HEPA filter, or the like. In an embodiment, absorbent materials may be used in a filter, in the adjustable bed facility 102, in the mattress 110, or the like to absorb odor, dust, contaminants, or the like from the air environment around the bed, within the bed, or the like. In an embodiment, electro-static or ionic air filters may use negative ions to attract dust, contaminants, and the like from the air. In an embodiment, electro-static materials (e.g. tourmaline) may be used in a filter, in the adjustable bed facility 102, in the mattress 110, or the like to absorb odor, dust, contaminants, or the like from the air environment around the bed, within the bed, or the like. In an embodiment, HEPA filters are composed of a mat of randomly arranged fibers that are designed to trap at least 99.97% of dust, pollen, mold, bacteria, and any airborne particles with a size of 0.3 micrometers (μm) at 85 liters per minute (Lpm). The HEPA filter may be used in a device, facility, or the like for filtering the air in the area of the adjustable bed facility 102.

[0229] In an embodiment, the air purification facility 144 may be part of the adjustable bed facility 102, a freestanding device or facility, or the like. In an embodiment, if the air purification facility 144 is part of the adjustable bed facility 102 the air purification facility 144 may be attached to any part of the adjustable bed facility 102 such as the mattress 110, sub-frame 112, skeleton structure 114, or the like. In an embodiment, the air purification facility 144 that is attached to the adjustable bed facility 102 may be controlled direct control of the air purification facility 144, control using the remote 148, or the like.

[0230] In an embodiment, the air purification facility 144 may be a free standing device that may be plugged into an adjustable bed facility 102 power outlet 138 and therefore may be controlled with the remote 148 controlling the on/off condition of the power outlet 138.

[0231] In an embodiment, the air purification facility 144 may be a freestanding device that may be connected to an adjustable bed facility 102 modular control 128. The modular control may provide power (AC or DC), control communication, and the like to the air purification facility 114. In an embodiment, the user may be able to control the air purification facility 144 using the remote 148 to control the modular controls 132.

[0232] In an embodiment, the remote 148 may be a user controlled device to provide control commands to the control box 134 to command certain functions of the adjustable bed facility 102. In an embodiment, the certain functions may be adjustable bed facility section movement (e.g. up or down), vibration control, modular controlled 132 devices, or the like. In an embodiment, the remote 148 may communicate with the control box using wired communication, wireless communication, or the like. In an embodiment, the wireless communication may be using a radio frequency (RF), infrared (IR), Bluetooth, or the like. If the remote communicates using a

wireless technology, the communication may be with the receiver 130 and the receiver 130 may pass the command request to the control box 134.

[0233] In an embodiment, the user may indicate the certain adjustable bed facility 102 function using the remote 148 by pressing a button, touching a screen, entering a code, speaking a command, or the like. In an embodiment, the control box 134, using the receiver 130, may receive and interpret the command provided by the remote 148. In an embodiment, the certain functions available on the remote may instruct the control box 134 to directly control a device (e.g. actuator 104), control a modular control 132 connected device, or the like. The remote may control devices with commands that may include on, off, high power, medium power, low power, volume, play, fast forward, rewind, skip, modular device to control, or the like. For example, the remote 148 may transmit a command to move the head section up and the control box 134 may command the actuator 104 to extend a certain amount in response to the command. In another example, the remote 148 may command that a modular control 132 connected lamp be turned off. The control box 134 may command the control box 132 to turn off the lamp.

[0234] In an embodiment, the remote 148 may save adjustable bed facility 102 user preferred settings to a plurality of memory locations that may be used to maintain the user determined bed position, an adjustable bed facility 102 historical setting, or the like. For example, the user may have a certain preferred adjustable bed facility 102 position that may be stored in at least one of the memory locations that the user may be able to later recall to move the adjustable bed facility into the user preferred position. By indicating the recall of the at least one memory locations, the adjustable bed facility 102 control box 134 may command the various components to move to the stored memory location position to achieve the recalled position. In an embodiment, for a remote 148 that may contain buttons, the user may press a single button, a combination of buttons, or the like to recall the memory position desired.

[0235] In an embodiment, the remote 148 may have buttons, an LCD screen, a plasma screen or the like to allow the user to indicate the desired command. In an embodiment, the user may press a button to indicate a command to the control box 134. In an embodiment, the LCD or plasma screens may be touch screen sensitive. In an embodiment, the remote 148 screen may present the available controls to the user and the user may touch the screen to indicate the command desired. For example, the remote 148 screen may only present controls that are available in the adjustable bed facility 102; therefore if a modular control 132 is not available, the remote 148 may not display a selection for that modular control 132. In an embodiment, the remote 148 screen may present content sensitive selections to the user. For example, if the user selected to control a CD player, the user may be presented with CD player controls that may include play, fast forward, rewind, skip, stop, repeat, or the like.

[0236] In an embodiment, the remote 148 may provide feedback to the user to indicate the success of the certain command. In an embodiment, the feedback may be an audio feedback, a visual feedback, a forced feedback, or the like. In an embodiment, the feedback types may be used individually or in combination. In an embodiment, the audio feedback may be a sound that indicates that the command was successful, failed, is in progress, in conflict with a command in progress, failed for safety reasons, or the like. In an embodi-

ment, the visual feedback may be an indication of the remote 148 screen that indicates that the command was successful, failed, is in progress, in conflict with a command in progress, failed for safety reasons, or the like. In an embodiment, the forced feedback may be a vibration that indicates that the command was successful, failed, is in progress, in conflict with a command in progress, failed for safety reasons, or the like.

[0237] In an embodiment, a memory facility 150 may contain components that are intended to maintain certain memory locations for the control box to access, receiver to access, and the like. In an embodiment, the memory facility 150 may include a receiver learn facility 152, a bed memory 154, a backup battery 158, and the like. In an embodiment, the receiver learn facility 152, bed memory 154, and backup battery 158 may be in a single memory facility 150 or may be in more than one memory facilities 150. In an embodiment, the memory facility 152 may be part of the adjustable bed facility 102, part of the electronic facility 124, a separate facility, or the like. In an embodiment, the receiver learn facility 152, bed memory 154, and backup battery 158 may not be part of the memory facility 150, but may be combined into other facilities or devices, be stand-alone devices, or the like.

[0238] In an embodiment, the receiver learn facility 152 may act to establish the communication link between the remote 148 and the receiver 130 where the communication between the remote 148 and receiver 130 is a wireless connection. In an embodiment, the communication link between the remote 148 and the receiver 130 may need to be a unique connection to assure that the remote 148 communicates with only one receiver 130 within one adjustable bed facility 102. In an embodiment, the receiver learn facility 152 may be used to provide a unique communication between any remote 148 and any adjustable bed facility 102. For example, a remote 148 may be used to communicate with a first adjustable bed facility 102 and may be used to establish communication between the same remote and a second adjustable bed facility 102. The remote 148 may only be able to communicate with one adjustable bed facility 102 at a time.

[0239] In an embodiment, a learn protocol between the remote 148 and receiver 130 may be user initiated by pressing a button on the receiver learn facility 152, powering up the receiver learn facility 152, bringing the receiver learn facility 152 within a certain proximity of the receiver 130, indicating on the remote 148 to begin the learn protocol, or the like. In an embodiment, the learn protocol may be fully automatic, semi-automatic with user intervention, manual, or the like. In an embodiment, a user may select a channel, frequency, or the like during learn protocol or after the learn protocol. The changing of the channel, frequency, or the like may prevent two different remote 148 and receiver 130 combinations from interfering with other wireless communication devices. In an embodiment, each time the learn protocol is executed, a new unique communication link may be established; there may be a plurality of unique communication links available for each remote 148 and receiver 130 combination.

[0240] In an embodiment, the bed memory 154 may be the memory location where the control box 134 stores user desired preset information, software for interpreting remote 148 commands, demonstration software, and the like. In an embodiment, the bed memory 154 may be removable memory. For example, the bed memory 154 may be moved from a first adjustable bed facility 102 to a second bed facility

102 to move user settings from the first adjustable bed facility **102** to the second bed facility **102**. In this manner the bed memory **154** may be considered portable memory. In an embodiment, the removable bed memory **154** may be flash memory, programmable logic circuit (PLC) memory, secure digital (SD) memory, mini SD memory, Compact Flash type I memory, Compact Flash type II memory, Memory Stick, Multimedia Card, xD Picture card, Smartmedia, eXtreme Digital, Microdrive, or the like.

[0241] In an embodiment, the removable bed memory **154** may be used to upgrade the adjustable bed facility **102** memory and software. For example, if new control box **134** software was developed to provide better control over one of the adjustable bed facility **102** components, the software may be saved to a new replaceable memory that may be used in the place of the existing replaceable memory. In this manner, the software of the adjustable bed facility **102** could be upgraded just by providing the user with a new replaceable memory.

[0242] In an embodiment, the removable memory may be used to provide a sales enterprise with adjustable bed facility **102** demonstration software where the enterprise may be able to indicate at least one of a plurality of demonstrations for a user. For example, the user may be interested in how the adjustable bed facility **102** sections may be adjusted and the enterprise may select a demonstration to shows all the section motion available. In an embodiment, before an adjustable bed facility **102** is shipped to a user, the enterprise may remove the demonstration removable memory and replace it with a standard adjustable bed facility **102** bed memory **154**.

[0243] In an embodiment, the backup battery **158** may be used to provide power to volatile memory, provide power to the receiver learn facility **152**, provide power to the programmable logic circuit (PLC) memory, or the like.

[0244] In an embodiment, the memory connection **160** may be any connection type that provides a connection between the bed memory **154**, control box **134**, and the like. In an embodiment, the memory connection **160** may be a wired or wireless connection. The wired connection may be a USB connection, a serial connection, parallel connection, or the like. The wireless connection may be by radio frequency (RF), infrared (IR), Bluetooth, or the like. In an embodiment, the memory connection **160** may be in a location that is easy for the user to access the bed memory **154**, may be attached to the memory facility **150**, may be attached to the control box **134**, or the like. In an embodiment, the easy access memory connection may be on the side of the adjustable bed facility **102**, on a rail of the adjustable bed facility **102**, under the adjustable bed facility **102**, or the like.

[0245] In an embodiment, the network connection **162** may be used to connect the control box **134** to a network connection. In an embodiment, the network connection may be a LAN, a WAN, an Internet, an intranet, peer-to-peer network, or the like. Using the network connection **162**, the control box **134** may be able to communicate with computer devices on the network. In an embodiment, the network connection **162** may be a wired or wireless connection.

[0246] In an embodiment, using the network connection **162**, the control box **134** may be able to communicate with the network to periodically check for software updates. In an embodiment, if a software update is located, the control box **134** may send the user an email, instant messenger message, phone message, phone call, cell phone message, cell phone call, fax, pager message, or the like to indicate that software updates are available. The user, using the device that received

the notice of software, may send a reply to the control box that the software upgrade should be downloaded, should not be downloaded, or the like.

[0247] In an embodiment, an adjustable bed facility **102** enterprise, an adjustable bed facility **102** manufacturer, an adjustable bed facility **102** service enterprise, or the like may send the control box **134** software updates using the network connection **162**. In an embodiment, an adjustable bed facility **102** enterprise, an adjustable bed facility **102** manufacturer, an adjustable bed facility **102** service enterprise, or the like may notify the user of available software upgrades for the adjustable bed facility **102** by email, instant messenger message, phone message, phone call, cell phone message, cell phone call, fax, pager message, or the like. The user, using the device that received the notice of software, may send a reply to the adjustable bed facility **102** enterprise, the adjustable bed facility **102** manufacturer, the adjustable bed facility **102** service enterprise, or the like that the software upgrade should be downloaded, should not be downloaded, or the like.

[0248] Referring now to FIG. 4, an embodiment of shipping and assembling a mattress retaining bracket **402** is shown. The mattress retaining bracket **402** may be used to hold the mattress **110** (not shown) in place on the adjustable bed facility **102** as the adjustable bed facility **102** sections are adjusted. For example, as the head section is adjusted up, the mattress **110** may tend to slide down towards the foot of the bed, the mattress retaining bracket **402** may stop the mattress from sliding and may maintain the mattress **110** in the proper position on the adjustable bed facility **102**. In an embodiment, there may be a mattress retaining **402** bracket at the head section and/or the foot section of the adjustable bed facility **102**.

[0249] In an embodiment, the mattress retaining bracket **402** may be made of materials that include metal, plastic, rubber, wood, or the like. In an embodiment, the materials may be used individually or in combination.

[0250] In an embodiment, as shown in VIEW A, when the adjustable bed facility **102** is shipped to the user, the mattress retaining bracket **402** may be mounted upside down at the final location of the mattress retaining bracket **402**. This mounting method may provide benefits that may include mattress retaining bracket **402** breakage prevention, mattress retaining bracket **402** bending prevention, clear user understanding of the final mattress retaining bracket **402** location, prevention of the mattress retaining bracket **402** becoming lost, and the like. In an embodiment, as shown in VIEW B, once the user receives the adjustable bed facility **102** with the upside down mounted mattress retaining bracket **402**, the user may rotate the mattress retaining bracket **402** into the upright position and re-secure it to the adjustable bed facility **102**.

[0251] Referring to FIG. 6, an example of an adjustable bed **600** (without the mattress) is shown with the head **602** and foot **604** sections raised to an elevated position. This adjustable bed **600** shows that sections, in this case the foot **604** section, may be divided into more than one section to provide contouring of bed sections.

[0252] Referring to FIG. 7, an example of actuators **104** connected to the bed frame **702** and the adjustable sections **704** is shown. In this case two actuators **104** are used, one for each adjustable bed section **704**.

[0253] Referring to FIG. 8, an example of more than one actuator **104** for each adjustable bed section **802** is shown, in this case there are two actuators **104** for each adjustable section **802**. In embodiments, more than one actuator **104** per

section 802 may be used if the bed sections 802 are heavy, smaller actuators 104 are used, if the bed is a wide bed (e.g. king bed), or the like.

[0254] Referring to FIG. 9, an example of an adjustable bed 900 using slats 902 instead of wood decking for the foundation of the adjustable sections is shown. In embodiments, the slats 902 may be wood, plastic, rubber, cloth, elastic material, or the like. Using this design, the adjustable bed 900 may be provided with curved contours has shown in the head section 904. In an embodiment, the curved sections may be constructed of a number of small connected individual sections.

[0255] The elements depicted in flow charts and block diagrams throughout the figures imply logical boundaries between the elements. However, according to software or hardware engineering practices, the depicted elements and the functions thereof may be implemented as parts of a monolithic software structure, as standalone software modules, or as modules that employ external routines, code, services, and so forth, or any combination of these, and all such implementations are within the scope of the present disclosure. Thus, while the foregoing drawings and description set forth functional aspects of the disclosed systems, no particular arrangement of software for implementing these functional aspects should be inferred from these descriptions unless explicitly stated or otherwise clear from the context.

[0256] Similarly, it will be appreciated that the various steps identified and described above may be varied, and that the order of steps may be adapted to particular applications of the techniques disclosed herein. All such variations and modifications are intended to fall within the scope of this disclosure. As such, the depiction and/or description of an order for various steps should not be understood to require a particular order of execution for those steps, unless required by a particular application, or explicitly stated or otherwise clear from the context.

[0257] The methods or processes described above, and steps thereof, may be realized in hardware, software, or any combination of these suitable for a particular application. The hardware may include a general-purpose computer and/or dedicated computing device. The processes may be realized in one or more microprocessors, microcontrollers, embedded microcontrollers, programmable digital signal processors or other programmable device, along with internal and/or external memory. The processes may also, or instead, be embodied in an application specific integrated circuit, a programmable gate array, programmable array logic, or any other device or

combination of devices that may be configured to process electronic signals. It will further be appreciated that one or more of the processes may be realized as computer executable code created using a structured programming language such as C, an object oriented programming language such as C++, or any other high-level or low-level programming language (including assembly languages, hardware description languages, and database programming languages and technologies) that may be stored, compiled or interpreted to run on one of the above devices, as well as heterogeneous combinations of processors, processor architectures, or combinations of different hardware and software.

[0258] Thus, in one aspect, each method described above and combinations thereof may be embodied in computer executable code that, when executing on one or more computing devices, performs the steps thereof. In another aspect, the methods may be embodied in systems that perform the steps thereof, and may be distributed across devices in a number of ways, or all of the functionality may be integrated into a dedicated, standalone device or other hardware. In another aspect, means for performing the steps associated with the processes described above may include any of the hardware and/or software described above. All such permutations and combinations are intended to fall within the scope of the present disclosure.

[0259] While the invention has been disclosed in connection with the preferred embodiments shown and described in detail, various modifications and improvements thereon will become readily apparent to those skilled in the art. Accordingly, the spirit and scope of the present invention is not to be limited by the foregoing examples, but is to be understood in the broadest sense allowable by law.

[0260] All documents referenced herein are hereby incorporated by reference.

What is claimed is:

1. An adjustable bed, comprising:
 - an adjustable bed frame including one or more articulating portions;
 - a programmable logic controller (PLC) associated with the adjustable bed frame adapted to control at least one adjustable aspect of the adjustable bed; and
 - a remote storage location of user preferences, wherein the user preferences represent recall parameters accessible by the PLC relating to one or more adjustable aspects of the adjustable bed.

* * * * *