

(19) World Intellectual Property Organization  
International Bureau



(43) International Publication Date  
8 January 2009 (08.01.2009)

PCT

(10) International Publication Number  
**WO 2009/005758 A3**

- (51) International Patent Classification:  
*H03M 7/40* (2006.01)
- (21) International Application Number:  
PCT/US2008/008107
- (22) International Filing Date: 26 June 2008 (26.06.2008)
- (25) Filing Language: English
- (26) Publication Language: English
- (30) Priority Data:  
11/824,501 29 June 2007 (29.06.2007) US  
11/849,166 31 August 2007 (31.08.2007) US  
12/031,524 14 February 2008 (14.02.2008) US
- (71) Applicant (for all designated States except US): **RMI CORPORATION** [US/US]; 18920 Forge Drive, Cupertino, California 95014 (US).
- (72) Inventors; and
- (75) Inventors/Applicants (for US only): **LAKER, Robert William** [GB/US]; 18920 Forge Drive, Cupertino, California 95014 (US). **HASS, David T.** [US/US]; 18920

- Forge Drive, Cupertino, California 95014 (US). **KUILA, Kaushik** [IN/US]; 18920 Forge Drive, Cupertino, California 95014 (US).
- (74) Agent: **ZILKA, Kevin J.**; Zilka-Kotab, PC, P.O. Box 721120, San Jose, California 95172-1120 (US).
- (81) Designated States (unless otherwise indicated, for every kind of national protection available): AE, AG, AL, AM, AO, AT, AU, AZ, BA, BB, BG, BH, BR, BW, BY, BZ, CA, CH, CN, CO, CR, CU, CZ, DE, DK, DM, DO, DZ, EC, EE, EG, ES, FI, GB, GD, GE, GH, GM, GT, HN, HR, HU, ID, IL, IN, IS, JP, KE, KG, KM, KN, KP, KR, KZ, LA, LC, LK, LR, LS, LT, LU, LY, MA, MD, ME, MG, MK, MN, MW, MX, MY, MZ, NA, NG, NI, NO, NZ, OM, PG, PH, PL, PT, RO, RS, RU, SC, SD, SE, SG, SK, SL, SM, SV, SY, TJ, TM, TN, TR, TT, TZ, UA, UG, US, UZ, VC, VN, ZA, ZM, ZW.
- (84) Designated States (unless otherwise indicated, for every kind of regional protection available): ARIPO (BW, GH, GM, KE, LS, MW, MZ, NA, SD, SL, SZ, TZ, UG, ZM, ZW), Eurasian (AM, AZ, BY, KG, KZ, MD, RU, TJ, TM), European (AT, BE, BG, CH, CY, CZ, DE, DK, EE, ES, FI,

[Continued on next page]

(54) Title: SYSTEM AND METHOD FOR COMPRESSION PROCESSING WITHIN A COMPRESSION ENGINE

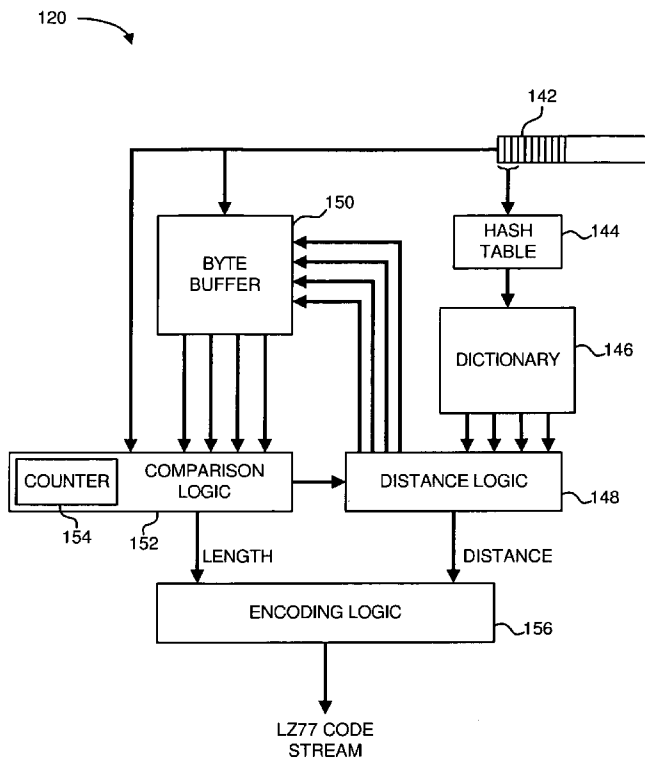

FIG. 5

(57) Abstract: An apparatus to implement a deflate process in a compression engine. An embodiment of the apparatus includes a hash table, a dictionary, comparison logic, and encoding logic. The hash table is configured to hash a plurality of characters of an input data stream to provide a hash address. The dictionary is configured to provide a plurality of distance values in parallel based on the hash address. The distance values are stored in the dictionary. The comparison logic is configured to identify a corresponding length for each matching distance value from the plurality of distance values. The encoding logic is configured to encode the longest length and the matching distance value as a portion of a LZ77 code stream.

WO 2009/005758 A3



FR, GB, GR, HR, HU, IE, IS, IT, LT, LU, LV, MC, MT, NL,  
NO, PL, PT, RO, SE, SI, SK, TR), OAPI (BF, BJ, CF, CG,  
CI, CM, GA, GN, GQ, GW, ML, MR, NE, SN, TD, TG).

— *before the expiration of the time limit for amending the  
claims and to be republished in the event of receipt of  
amendments*

**Published:**

— *with international search report*

**(88) Date of publication of the international search report:**

2 April 2009

**INTERNATIONAL SEARCH REPORT**

International application No.

PCT/US 08/08107

**A. CLASSIFICATION OF SUBJECT MATTER**

IPC(8) - H03M 7/40 (2008.04)  
USPC - 341/65

According to International Patent Classification (IPC) or to both national classification and IPC

**B. FIELDS SEARCHED**

Minimum documentation searched (classification system followed by classification symbols)  
USPC: 341/65

Documentation searched other than minimum documentation to the extent that such documents are included in the fields searched  
USPC: 341/51, 64, 65, 63, 95; 375/130, 240, E7.033 keyword limited - see search terms below

Electronic data base consulted during the international search (name of data base and, where practicable, search terms used)  
PubWest (PGPB,USPT,USOC,EPAB,JPAB), Google Scholar, Google Patent  
Search terms: LZ77, Lempel, Ziv, Huffman, data, compression, parallel, hash, dictionary, DEFLATE, comparator, literal, sliding window

**C. DOCUMENTS CONSIDERED TO BE RELEVANT**

Category*	Citation of document, with indication, where appropriate, of the relevant passages	Relevant to claim No.
X ----- Y	US 5,970,177 A (CHINNOCK) 19 October 1999 (19.10.1999), col 1, ln 27-31, 42-55, col 1, ln 67 to col 2, ln 53, col 4, ln 15-43, col 9, ln 23-32, 39-58	40 ----- 1-39, 45-51
X ----- Y	US 2002/0063641 A1 (FISH) 30 May 2002 (30.05.2002), para [0008], [0010], [0015]-[0017], [0049], [0080]	41-44 ----- 45-51
Y	US 2001/0054131 A1 (ALVAREZ et al.) 20 December 2001 (20.12.2001), para [0021], [0046], [0162], [0210], [0220]-[0222], [0228]-[0234]	1-39

Further documents are listed in the continuation of Box C.

\* Special categories of cited documents:

"A" document defining the general state of the art which is not considered to be of particular relevance  
"E" earlier application or patent but published on or after the international filing date  
"L" document which may throw doubts on priority claim(s) or which is cited to establish the publication date of another citation or other special reason (as specified)  
"O" document referring to an oral disclosure, use, exhibition or other means  
"P" document published prior to the international filing date but later than the priority date claimed

"T" later document published after the international filing date or priority date and not in conflict with the application but cited to understand the principle or theory underlying the invention  
"X" document of particular relevance; the claimed invention cannot be considered novel or cannot be considered to involve an inventive step when the document is taken alone  
"Y" document of particular relevance; the claimed invention cannot be considered to involve an inventive step when the document is combined with one or more other such documents, such combination being obvious to a person skilled in the art  
"&" document member of the same patent family

Date of the actual completion of the international search

14 January 2009 (14.01.2009)

Date of mailing of the international search report

30 JAN 2009

Name and mailing address of the ISA/US

Mail Stop PCT, Attn: ISA/US, Commissioner for Patents  
P.O. Box 1450, Alexandria, Virginia 22313-1450  
Facsimile No. 571-273-3201

Authorized officer:

Lee W. Young

PCT Helpdesk: 571-272-4300  
PCT OSP: 571-272-7774

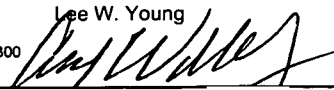

INTERNATIONAL SEARCH REPORT

International application No.

PCT/US 08/08107

**Box No. II Observations where certain claims were found unsearchable (Continuation of item 2 of first sheet)**

This international search report has not been established in respect of certain claims under Article 17(2)(a) for the following reasons:

- 1.  Claims Nos.:  
because they relate to subject matter not required to be searched by this Authority, namely:
  
- 2.  Claims Nos.:  
because they relate to parts of the international application that do not comply with the prescribed requirements to such an extent that no meaningful international search can be carried out, specifically:
  
- 3.  Claims Nos.:  
because they are dependent claims and are not drafted in accordance with the second and third sentences of Rule 6.4(a).

**Box No. III Observations where unity of invention is lacking (Continuation of item 3 of first sheet)**

This International Searching Authority found multiple inventions in this international application, as follows:  
Please See Continuation Sheet

- 1.  As all required additional search fees were timely paid by the applicant, this international search report covers all searchable claims.
- 2.  As all searchable claims could be searched without effort justifying additional fees, this Authority did not invite payment of additional fees.
- 3.  As only some of the required additional search fees were timely paid by the applicant, this international search report covers only those claims for which fees were paid, specifically claims Nos.:
- 4.  No required additional search fees were timely paid by the applicant. Consequently, this international search report is restricted to the invention first mentioned in the claims; it is covered by claims Nos.:  
1-51

**Remark on Protest**

- The additional search fees were accompanied by the applicant's protest and, where applicable, the payment of a protest fee.
- The additional search fees were accompanied by the applicant's protest but the applicable protest fee was not paid within the time limit specified in the invitation.
- No protest accompanied the payment of additional search fees.

INTERNATIONAL SEARCH REPORT  
Information on patent family members

International application No.

PCT/US 08/08107

Box I No. II Observations where unity of invention is lacking

This application contains the following inventions or groups of inventions which are not so linked as to form a single general inventive concept under PCT Rule 13.1. In order for all inventions to be examined, the appropriate additional examination fees must be paid.

Group I: Claims 1-51: directed to a method, apparatus and computer program for deflate processing within a compression engine comprising hashing a plurality of characters of an input data stream to provide a hash address into a dictionary; reading a plurality of distance values from the dictionary based on the hash address, wherein the distance values are stored in the dictionary; identifying a matching distance value from the plurality of distance values; and encoding the matching distance value with a length value as a portion of a LZ77 code stream.

Group II: claims 52-70: directed to an apparatus to implement Huffman decoding in an INFLATE process comprising a bit buffer to store a portion of a compressed data stream; a set of comparators coupled to the bit buffers to compare the portion of the compressed data stream with a plurality of predetermined values; and a lookup table coupled to the set of comparators to store a plurality of LZ77 code segments and to output one of the LZ77 code segments corresponding to an index at least partially derived from a comparison result from the set of comparators.

Group III: Claims 71- 81: directed to a method, system and computer program for processing data, the processing including compressing or decompressing the data; saving a state of the processing; and restoring the state of the processing.

The inventions listed as Groups I - III do not relate to a single general inventive concept under PCT Rule 13.1 because, under PCT Rule 13.2, they lack the same or corresponding special technical features for the following reasons:

Group I does not include implementing a Huffman decoding in an INFLATE as required by Group I or processing data, the processing including compressing or decompressing the data; saving a state of the processing; and restoring the state of the processing as required by Group III.

Group II does not include a deflate processing within a compression engine comprising hashing a plurality of characters of an input data stream to provide a hash address into a dictionary; reading a plurality of distance values from the dictionary based on the hash address, wherein the distance values are stored in the dictionary as required by Group I or processing data, the processing including compressing or decompressing the data; saving a state of the processing; and restoring the state of the processing as required by Group III.

Group III does not include deflate processing within a compression engine comprising hashing a plurality of characters of an input data stream to provide a hash address into a dictionary; reading a plurality of distance values from the dictionary based on the hash address, wherein the distance values are stored in the dictionary; identifying a matching distance value from the plurality of distance value as required by Group I or Huffman decoding in an INFLATE process comprising a bit buffer to store a portion of a compressed data stream; a set of comparators coupled to the bit buffers to compare the portion of the compressed data stream with a plurality of predetermined values as required by Group II.

Groups I and II share the technical feature of a LZ77 code stream/segment. However, this shared technical feature does not represent a contribution over the prior art of US 6,262,675 B1 to Iyer, which discloses that LZ77 is a well known data compression and decompression method (Title, Abstract and col 1, ln 13-16). As the above compression/decompression connector was well known at the time, as evidenced by the teaching of Iyer, this cannot be considered a special technical feature that would otherwise unify the groups.

Groups I-III therefore lack unity under PCT Rule 13 because they do not share a same or corresponding special technical feature.