



**(12) PATENT ABRIDGMENT (11) Document No. AU-B-67621/90**  
**(19) AUSTRALIAN PATENT OFFICE (10) Acceptance No. 643239**

- (54) Title  
**ELECTRICALLY POWERED LINEAR HEATING ELEMENT**
- International Patent Classification(s)  
(51)<sup>5</sup> **A24F 047/00 A24D 001/00 H05B 003/26**
- (21) Application No. : **67621/90** (22) Application Date : **30.11.90**
- (30) Priority Data
- (31) Number (32) Date (33) Country  
**444569 01.12.89 US UNITED STATES OF AMERICA**
- (43) Publication Date : **06.06.91**
- (44) Publication Date of Accepted Application : **11.11.93**
- (71) Applicant(s)  
**PHILIP MORRIS PRODUCTS INC.**
- (72) Inventor(s)  
**SEETHARAMA C. DEEVI; FRANCIS M. SPRINKEL**
- (74) Attorney or Agent  
**CALLINAN LAWRIE , Private Bag 7, KEW VIC 3101**
- (56) Prior Art Documents  
**AU 67620/90 A24F 47/00 A24D 1/00**  
**AU 67622/90 A24F 47/00 A24D 1/00 H05B 3/40**
- (57) Claim
1. An electrically-powered linear heating element for an electrically powered smoking article, comprising a linear base member (1), by at least one electrically-resistive linear heating member (3) switchably connectable to an electrical power source (5), said heating member having a resistivity which, when said heating member is connected to said power source, causes the heating member to attain a temperature sufficient to heat, without burning, a flavor-generating medium which is in thermal contact with said heating member, and by at least one linear insulating (2) member secured between the base member and the heating member, said insulating member having an electrical resistance sufficiently high to electrically isolate the heating member from the base member, said insulating member also having a thermal conductivity sufficiently low to thermally isolate the heating member from the base member.
4. An electrically-powered linear heating element for an electrically powered smoking article comprising at least one electrically-resistive linear heating member (3) switchably connectable to an electrical power source (5), the heating member having a resistivity which, when said heating member is connected

(11) AU-B-67621/90  
(10) 643239

-2-

to said power source, causes the heating member to attain a temperature sufficient to heat a flavor-generating medium, without burning, which is in thermal contact with said heating member, and by at least a linear base member (1) secured to said heating member, said base member comprising an electrically-insulating material capable of maintaining its structural integrity and chemical inertness throughout the range of operating temperatures of the heating member.

# COMPLETE SPECIFICATION

(ORIGINAL)

FOR OFFICE USE

Short Title:

Int. Cl:

Application Number:

Lodged:

Complete Specification - Lodged:  
Accepted:  
Lapsed:  
Published:

Priority:

Related Art:

---

TO BE COMPLETED BY APPLICANT

Name of Applicant:

PHILIP MORRIS PRODUCTS INC.

Address of Applicant:

3601 Commerce Road, Richmond, Virginia 23234, United States of America.

Actual Inventors:

Seetharama C. Deevi and Francis M. Sprinkel.

Address for Service:

CALLINAN LAWRIE, 278 High Street, Kew, 3101, Victoria, Australia

Complete Specification for the invention entitled:

"ELECTRICALLY POWERED LINEAR HEATING ELEMENT"

The following statement is a full description of this invention, including the best method of performing it known to me:-

---

ELECTRICALLY-POWERED LINEAR HEATING ELEMENT

5           The present invention provides a heating  
element for use within a smoking device in which  
burning does not take place. More particularly, this  
invention relates to an electrically-powered heating  
element having a plurality of discrete electrically  
10 resistive heating segments, only one of which is active  
at any given time. The element is intended to heat a  
flavor-generating medium, which is contained within the  
device, without burning. As a result of this heating,  
the flavor-generating medium produces a flavored  
15 aerosol or vapor which the consumer may inhale.

          Previously known conventional smoking devices  
deliver flavor and aroma to the user as a result of  
combustion. During combustion, a mass of combustible  
material, primarily tobacco, is oxidized as the result  
20 of applied heat (typical combustion temperatures in a  
conventional cigarette are in excess of 800°C during  
puffing). During this heating, inefficient oxidation  
of the combustible material takes place and yields  
various distillation and pyrolysis products. As these  
25 products are drawn through the body of the smoking  
device toward the mouth of the user, they cool and  
condense to form an aerosol or vapor which gives the  
consumer the flavor and aroma associated with smoking.

Such conventional smoking devices have various perceived drawbacks associated with them. Among these is the production of sidestream smoke which may be objectionable to non-smokers in the vicinity of  
5 the consumer of the device.

An alternative to conventional smoking devices are those in which the combustible material itself does not directly provide the flavorants to the aerosol or vapor inhaled by the user. In these  
10 devices, a combustible heating element, typically carbonaceous in nature, is ignited and used to heat air which is then drawn through a zone which contains some means for producing a flavored aerosol or vapor upon interaction with the heated air. While this type of  
15 smoking device produces little or no sidestream smoke, it still shares some characteristics with conventional cigarettes which are perceived as undesirable.

In both the conventional and carbon element heated smoking devices described above combustion takes  
20 place during their use. This process naturally gives rise to many by-products as the material supporting the combustion breaks down and interacts with the surrounding atmosphere.

Additionally, the combustion process which  
25 takes place in both of the aforementioned types of smoking devices cannot be easily suspended by the user in order to allow storage of the smoking device for later consumption. Obviously a conventional cigarette may be extinguished prior to its being smoked to  
30 completion, but if the user wishes to save the remaining portion of the cigarette for later use, he is faced with the problem of storing a relatively small, ash laden paper tube; convenient storage for such an item would most likely not be readily available. Users  
35 of the carbon element heated combustible smoking

devices do not even have the option of extinguishing the device after it has been ignited, as the heating element contained within such devices is typically inaccessible to the user. Once lit, such carbon element smoking devices must be smoked to completion or discarded prior to completion while still burning.

5           Accordingly, it is the object of the present invention to provide for an electrically-powered heating element which will heat a flavor-generating medium without burning. According to the invention there is provided an electrically-powered linear heating element for an electrically powered smoking article, comprising a linear base member, by at least one electrically-resistive linear heating member switchably connectable to an electrical power source, said heating member 10 having a resistivity which, when said heating member is connected to said power source, causes the heating member to attain a temperature sufficient to heat, without burning, a flavor-generating medium which is in thermal contact with said heating member, and by at least one linear insulating member secured between the 15 base member and the heating member, said insulating member having an electrical resistance sufficiently high to electrically isolate the heating member from the base member, said insulating member also having a thermal conductivity sufficiently low to thermally isolate the heating member from the base member.

20           An element embodying the invention may be used to heat a flavor-generating medium which as a result of the heating, produces a flavored aerosol or vapor which the consumer could then inhale.

          Preferably, the heating element is configured so as to allow the consumer to operate the device in a puff by puff manner, with the option of suspending the operation of the



device after any given puff, prior to the depletion of the device. The device may then be conveniently stored until some later time at which the consumer wishes to resume operation.

The invention provides an electrically resistive linear heating element for use in a non-burning device. In a preferred embodiment the element consists of three component parts, namely a base region, an insulating region, and a heating region. Each heating region may consist of a single resistive heating segment, or be comprised of a plurality of electrically discrete resistive heating segments. In the former case, a plurality of heating elements may be used within a single device; in the latter, only a single heating element is required.

In operation, the heating element may be contained within a device, and the resistive heating

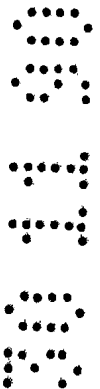

segments switchably connected to an electrical power source. Each element may be positioned within the device so that when power is supplied to a given resistive heating segment the heat produced by that segment is transferred to a portion of a flavor-generating medium, thus heating the medium. When so heated, this flavor-generating medium provides a flavored aerosol or vapor which the user of the device inhale. The supply of electrical power to a given heating segment may be coincident with the user puffing the device. With each puff, a different heating segment within the device may be supplied with power, until all the segments within the device have been supplied with power once; at this point the device is depleted. This switching of power between segments may be directly controlled by the user or triggered by control circuitry.

Smoking devices employing heating elements made in accordance with the principles of the present invention have certain advantages over combustion-type smoking devices. For example, such non-burning smoking devices give the user the sensation and flavor of smoking without actually creating some of the smoke components associated with combustion. This may allow the consumers of non-burning devices to enjoy the use of this device in areas where conventional smoking would be prohibited; such areas could include restaurants, offices, and commercial aircraft.

In addition, the elimination of burning from the process also prevents the creation of many of the by-products of burning. Because the heating element of the present invention never reaches a temperature which is sufficient to induce burning, such by-products are never produced.

A further advantage of this electrically-powered heating element is that it is very efficient in its utilization of electrical energy in heating the flavor-generating medium which provides the consumer with a flavored aerosol or vapor. The heating element is intended to receive electrical energy only during those periods when the device is being puffed, and only one heating segment is to be active during any given puff. This economy of energy consumption allows for a reduction in the amount of space which must be occupied by the element's power source, thus enabling a device in which the present invention is employed to be contained in a package which is comparable in size and shape to a conventional cigarette.

Moreover, the controllable nature of an element embodying the invention allows the consumer to stop consuming the article prior to operating it to completion, and to continue consuming the article at some later time. Also, as only one heating segment within the device is active at any given time, the heat produced by the device at any given time remains relatively low. This low heat level allows the consumer to store a previously active, but unfinished device for later use, without concern as to the device's elevated temperature; the device may be stored almost immediately after it was last puffed. Such intermittent use and convenient storage is not practical with burning-type smoking devices.

Furthermore, the nature of the construction of the heating element lends itself to economical, continuous production using simple manufacturing methods.

The above and other objects and advantages of this invention will be apparent on consideration of the following detailed description, taken in conjunction  
5 with the accompanying drawings, in which like reference characters refer to like parts throughout, and in which:

FIG. 1A is a side view of a three component embodiment of the electrically-powered heating element  
10 having a plurality of individual heating segments;

FIG. 1B is a perspective view of the embodiment of the electrically-powered heating element of FIG. 1A;

FIG. 1C is a perspective view of a portion of  
15 the heating element of FIG. 1A showing the connection of the individual heating segments to an electrical power source and switching means;

FIG. 2A is a side view of a five component embodiment of the electrically-powered heating element  
20 having a plurality of individual heating segments;

FIG. 2B is a perspective view of the embodiment of the electrically-powered heating element of FIG. 2A;

FIG. 3 is a partial cutaway perspective view  
25 of a the embodiment of the electrically-powered heating element of FIG. 1A, and an electrical power source and switching means positioned within a device;

FIG. 4 is a partial cutaway perspective view of the embodiment of the electrically-powered heating  
30 element of FIG. 2A, and an electrical power source and switching means positioned within a device;

FIG. 5A is a side view of a three component electrically-powered heating element having a singular heating segment;

FIG. 5B is a perspective view of the embodiment of the electrically-powered heating element of FIG. 5A;

FIG. 6A is a front view of an alternate embodiment of a three component electrically-powered heating element having a singular heating segment;

FIG. 6B is a perspective view of the embodiment of the electrically-powered heating element of FIG. 6A;

FIG. 7A is a partial cutaway perspective view of a portion of a smoking device showing the electrically-powered heating element of FIG. 6A positioned within;

FIG. 7B is a front view of the embodiment of the electrically-powered heating element of FIG. 6A positioned within a device;

FIG. 8A is a side view of a two component embodiment of the electrically-powered heating element having a plurality of individual heating segments; and

FIG. 8B is a perspective view of the embodiment of the electrically-powered heating element of FIG. 8A.

#### Detailed Description Of The Invention

A preferred embodiment of the linear heating element is shown in FIGS. 1A and 1B. It comprises three planar component regions; namely a base region 1, an insulating region 2, and a heating region 3.

In this three component embodiment the base region 1 provides for the physical support of the insulating and heating regions. The base region in this particular embodiment includes a metallic tape, such as aluminum foil tape. The tape, while being rigid enough to physically support the insulating and heating regions, can be flexible enough to facilitate

easy handling and resist fracturing during the manufacturing process. The metallic nature of the base region provides for the thermal stability of the heating element as most metals will not substantially  
5 deform or become chemically reactive at temperatures such as those encountered when the heating element is active.

Adjoining the base region, and physically separating it from the heating region, is the  
10 insulating region 2. This insulating region ~~must~~ <sup>should</sup> have a sufficiently low electrical conductivity so as to isolate the electrically resistive heating region from the electrically conductive metallic base region. Like the base region, the insulating region ~~must~~ <sup>should</sup> be  
15 thermally stable at the elevated temperatures which the active heating element would produce. In addition, this region should have a sufficiently high heat capacity so as to sink and buffer undesirable heat pulses which may be inadvertently produced by the  
20 heating region. This buffering prevents the flavor-generating medium from burning, which could detrimentally affect flavor and aerosol or vapor delivery. The insulating region can be fabricated using metallic oxides, metallic nitrides, metallic  
25 carbides, metallic silicides, nonmetallic oxides, nonmetallic nitrides, nonmetallic carbides, nonmetallic silicides, metallic carbonitride, an inter-metallic compound, a cermet, or an alloy of more than one metal. This region can also be composed of a combination of  
30 the elements of the previously mentioned list, to achieve the non-conducting, thermally-insulating, and structural properties needed for operation.

Such materials may be fabricated separately and then joined with the base material or applied to  
35 the base materials as a fabrication step: by a coating



process, a dip, mechanical pressing, slip casting, tape casting, extrusion, chemical vapor deposition, thermal spraying, plasma spraying, or any other method of pyrolytical or chemical deposition.

5                    Situated adjacent to the insulating region and opposite the base region is the heating region 3. In this particular embodiment the heating region is not continuous in nature, rather it is comprised of a plurality of electrically discrete resistive heating  
10 segments 4. Each of the heating segments is situated so that it may be switchably connected to a power source in a manner which would allow current from the power source to be directed through a given segment thereby heating it. This switching of power to a  
15 particular segment could be directly controlled by the user or triggered by control circuitry. As illustrated in FIG. 1C, the connection between the heating segments 4 and an electrical power source and switching means 5 (such means includes any control circuitry)  
20 could be facilitated by conventional wires 6 attached to each of the segments. The resistivity of an individual heating segment must be such that when current flows through a given segment a temperature sufficient to induce the flavor-generating medium to  
25 produce an aerosol or flavor or vapor is achieved; typically this temperature is between about 100°C and 600°C, preferably between about 250°-500°C and most preferably between about 350°-450°C. However, the resistivity cannot be so high as to impede the heating  
30 of the flavor-generating medium, using multiple batteries. Nor can it be so low that the power consumption requirement of the segment exceeds the capacity of the source. Typically, heating segments having resistances between 0.2 and 20.0 ohms, and  
35 preferably between 0.5 and 1.5 ohms, and most

preferably between 0.8 and 1.2 ohms, can achieve such operating temperatures when connected across a potential of between 2.4 and 9.6 volts.

Throughout their range of operating  
5 temperatures, the heating segments must be chemically non-reactive with the flavor-generating medium being heated, so as not to adversely affect the flavor or content of the aerosol or vapor produced by the flavor-generating medium. The heating segments may be  
10 composed of carbon, graphite, carbon/graphite composites, metallic and non-metallic carbides, nitrides, silicides, inter-metallic compounds, cermets, alloys of metals, or Rare Earth and refractory metal foils, and may be deposited using any of the methods  
15 which were previously specified as being suitable for the deposition of the insulating region. Alternatively, they may be fabricated separately and laminated or otherwise assembled. Different materials can be mixed to achieve the desired properties of resistivity,  
20 mass, thermal conductivity and surface properties. The preferred materials are graphite-carbon composites.

An additional preferred embodiment is shown in FIGS. 2A and 2B. A base region 1 is adjoined on two opposing sides by insulating regions 2, and a heating region 3 is situated adjacent to each of these  
25 insulating regions and opposite the base region. As in the previously described embodiment, each of the heating regions is comprised of a plurality of electrically-discrete resistive heating segments 4.  
30 Each of these component regions is similar in composition, fabrication, and physical characteristics, to the like named regions which were disclosed in the description of the first embodiment. The operation of this five component embodiment of the heating element  
35 is primarily the same as that of the three component

embodiment. The heating segments would be connected to a power source and switching means by conventional wires, as in the previously described three-component embodiment, with the exception that in the instant  
5 embodiment the heating segments would be switchably connected to a power source and switching means in a manner where two segments would be active at a given time. During a puff, power would be supplied to a pair  
10 of heating segments, one in each of the two heating regions. Such a two-sided heating element would increase the surface area of flavor-generating medium adjacent to an active heating segment during a puff.

All of the embodiments of the heating element which have been heretofore described may be situated  
15 within a cylindrical device having an outside diameter of between 6 and 18 millimeters. As shown in FIG. 3, the heating element 7 is mounted axially within the body 8 of a device in such a manner as to allow the consumer of the device to draw air from the far end 9  
20 of the device, causing the air to pass over the element, and exit at the mouthpiece end 10 of the device. The power source and switching means 5 for the element is shown to be attached to the interior wall of the device in a manner which would not interfere with  
25 the flow of air through the device (for the sake of visual clarity, the wiring connecting the power source and switching means and the individual heating segments is not shown).

FIG. 4 shows a five component segmented  
30 heating element 7 similarly situated within a smoking device 8. Again the consumer may draw air from the far end 9 of the device, past the power source and switching means 5, over the element 7, and out of the mouthpiece end 10 of the device (as in FIG. 3, the  
35 wiring connecting the power source and switching means

and the individual heating segments is not shown). In an alternative embodiment, air can also enter through the outside wall of the device, pass around the heater array, and then exit the mouth end 10.

5 Although all regions have been shown in the figures as being planar and rectangular, they may also be curled or spiral, to achieve the required surface area for heating within the size of the device.

10 Yet another preferred embodiment of the linear heating element is shown in FIGS. 5A and 5B. It includes three planar component regions; namely a base region 1, an insulating region 2, and a heating region 3. In this three-component embodiment, the base region 1, the insulating region 2, and the heating region 3 are similar in composition and function to the like-named regions in the previously described  
15 embodiments. However, the heating region is comprised of a singular, continuous, electrically resistive area, as opposed to a plurality of discrete resistive heating  
20 segments.

FIGS. 6A and 6B show an alternative preferred embodiment of the heating element, which is identical in all respects to the above described embodiment, except that the component regions are arched rather  
25 than planar in nature.

The embodiments of the heating element which have a single resistive heating segment may be employed within a device which is similar in size and shape to a conventional cigarette. As pictured in FIG. 7A, a  
30 plurality of these heating elements 7 are situated radially within the body of device 8 in such a manner as to allow the user of the device to draw air from the far end of the device, or through the exterior wall, into channels 11, which allow the air to pass over the  
35 elements before exiting at the mouthpiece end of the



device. The power source and switching means for the element could be housed anywhere within the central core 12 of the device, without regard to obstructing the air flow through the device (such flow is  
5 facilitated by the channels 11 within the body of the device 8). FIG. 7B is cross-sectional view of such a smoking device showing the base region 1, insulating region 2 and heating region 3 of the heating elements 7, which are radially arranged within the body  
10 of the device 8.

In all of the previously described embodiments, the base region has been a metallic tape; however, in any of the above embodiments, this region could alternately be comprised of a foam mat, or a  
15 woven or non-woven fiber mat. Materials such as graphite, carbon, a metallic carbonitride, silicon dioxide, silicon carbide, or alumina could be used to fabricate the base region mat. The mat, while being rigid enough to physically support the heating and  
20 insulating regions, can be flexible enough to facilitate easy handling and resist fracturing during the manufacturing process. In addition, the base region mat must be thermally stable at high  
25 temperatures to ensure that it will not react with the neighboring heating region or decompose at elevated temperatures produced when the heating element is active.

When employed as a base region, a mat provides certain advantages over a solid tape. Unlike  
30 a tape, the mat is comprised of either a large number of individual fibers (with voids existing between those fibers), or a foam having many minute voids located throughout its structure. By impregnating the mat with a flavor-generating medium, thus filling the voids in  
35 that mat with the flavor-generating medium, a

relatively large amount of the flavor-generating medium may be brought within close proximity of the resistive heating segments of the heating element. Such an arrangement would promote the efficient heating of the flavor-generating medium. The fibers or foam structure of the base region would provide an effective means of channeling the heat produced by the resistive heating segments to the flavor-generating medium, while at the same time sinking some of the heat so as to buffer the flavor-generating medium from any undesirable heat pulses, which might otherwise result in the burning of the flavor-generating medium.

In any of the above described embodiments, regardless of whether the base region was comprised of a tape or a mat, the insulating region could be eliminated if the base region were to be fabricated from a material which would permit the heating segments to be placed in direct contact with it. That is to say, the base material would have to remain chemically and physically stable when directly exposed to the elevated temperatures of the active heating segments. In addition, such a base material would have to have a low enough electrical conductivity so as to insure that the individual heating segments remained electrically isolated from each other. The base region material would also have to exhibit a sufficiently high heat capacity so as to sink and buffer undesirable heat pulses which may be inadvertently produced by the heating region. However, it must not be so high as to impede the heating of the flavor-generating medium to a temperature sufficient to allow the production of an aerosol or vapor. This buffering would protect the flavor-generating medium from burning, which could detrimentally affect flavor and aerosol or vapor delivery. Alumina and other ceramic materials could be

used to fabricate such a base region. Metallic and nonmetallic carbides, nitrides, silicides, oxides, metallic carbonitrides, inter-metallic compounds, and cermets (ceramic/metallic composites) can also be used to produce the mat material and to tailor the specific properties or resistivities, heat capacity, mass, surface area and texture for optimum performance. An example of such an embodiment is illustrated in FIGS. 8A and 8B. The heating region 3, composed of a plurality of discrete resistive heating segments 4, is adjacent to the base region 1.

Furthermore, in any of the above described embodiments, an additional protective region could be deposited which would envelop the heating region. Such a region would only be needed when the material which formed the heating region proved to be chemically reactive with the flavor-generating medium to be heated. This protective region would physically isolate the heating region from the flavor-generating medium, and would prevent any undesirable effects upon the flavor or content of the aerosol or vapor produced by the flavor-generating medium during heating. Naturally, the protective region must itself be formed of a material which is stable at elevated temperatures and chemically non-reactive with the flavor-generating medium. The protective region must also have a sufficiently low electrical conductivity so as not to compromise the electrical isolation of the discrete resistive heating segments. Finally, the thermal conductivity of such a protective region must be high enough to allow a sufficient quantity of heat to be transferred from each heating region to the flavor-generating medium to facilitate the production of an aerosol or vapor by the flavor-generating medium. The protective region could be fabricated from materials

such as graphite, silicate glass, high-temperature vitreous enamel, metallic and nonmetallic oxides, carbides, nitrides, silicides or metallic carbonitride, or cermet. Such materials may be applied to  
5 the heating element by a coating process, a dip, mechanical pressing, slip casting, tape casting, chemical vapor deposition, extrusion, thermal spraying, plasma spraying, or any other method of low temperature, pyrolytical, or chemical deposition.

10 It will be understood that the particular embodiments described above are only illustrative of the principles of the present invention, and that various modifications could be made by those skilled in the art without departing from the scope and spirit of  
15 the present invention, which is limited only by the claims that follow.

**The claims defining the invention are as follows**

1. An electrically-powered linear heating element for an electrically powered smoking article, comprising a linear base member (1), by at least one electrically-resistive linear heating member (3) switchably connectable to an electrical power source (5), said heating member having a resistivity which, when said heating member is connected to said power source, causes the heating member to attain a temperature sufficient to heat, without burning, a flavor-generating medium which is in thermal contact with said heating member, and by at least one linear insulating (2) member secured between the base member and the heating member, said insulating member having an electrical resistance sufficiently high to electrically isolate the heating member from the base member, said insulating member also having a thermal conductivity sufficiently low to thermally isolate the heating member from the base member.

2. An electrically-powered linear heating element according to Claim 1, comprising a pair of the said electrically-resistive linear heating members (3) and a pair of the said linear insulating members (2), the insulating members each being disposed along a respective side of the base member and secured to a respective one of the resistive heating members.

3. The electrically-powered heating element according to Claim 1 or 2 wherein the base member comprises an element selected from the group consisting of metallic tape, metallic or nonmetallic oxide, carbides, nitrides, silicides, carbonnitrides, inter-metallic compounds, and cermet.



4. An electrically-powered linear heating element for an electrically powered smoking article comprising at least one electrically-resistive linear heating member (3) switchably connectable to an electrical power source (5), the heating member having a resistivity which, when said heating member is connected to said power source, causes the heating member to attain a temperature sufficient to heat a flavor-generating medium, without burning, which is in thermal contact with said heating member, and by at least a linear base member (1) secured to said heating member, said base member comprising an electrically-insulating material capable of maintaining its structural integrity and chemical inertness throughout the range of operating temperatures of the heating member.

5. An electrically-powered linear heating element according to claim 4 comprising a pair of the said electrically-resistive linear heating members (3) each arranged along a respective side of the linear base member.

6. The electrically-powered heating element of Claim 4 or 5, wherein the base member is fabricated from one of the group comprising carbides, nitrides, silicides, oxides, metallic carbonitrides, inter-metallic compounds, and cermet.

7. The electrically-powered heating element of any of Claim 1 to 6, wherein the or each electrically-resistive heating member comprises a plurality of electrically-discrete resistive segments (4), each of which is switchably and independently connectable to an electrical power source.

8. The electrically-powered heating element of any preceding claim, wherein the or each electrically-resistive heating member has a resistance of between 0.2 and 20.0 ohms.



9. The electrically-powered heating element of Claim 8 wherein the or each electrically-resistive heating member has a resistance of between about 0.5 and 1.5 ohms.

10. The electrically-powered heating element of claim 9, wherein the or each electrically-resistive heating member has a resistance of between about 0.8 and 1.2 ohms.

11. The electrically-powered heating element of any preceding claim, wherein the or each heating element is of a size which could be contained within a smoking device having an outside diameter of between 6 and 18 millimeters.

12. The electrically-powered heating element of any preceding claims, wherein the base member comprises a mat of fibers.

13. The electrically-powered heating element of any previous claim, wherein the heating element is encased in a protective coating, said protective coating providing a physical and chemical barrier between the heating element and its surroundings, and being substantially chemically non-reactive with the other components of the heating element and with the environment in which the heating element is to be used.

14. A non-combustible smoking article comprising a body (18) containing a flavor-generating medium and a linear heating element (7) according to any preceding claim.

15. An electrically-powered linear heating element for a device substantially as hereinbefore described with reference to the accompanying drawings.

DATED this 2nd day of September 1993.

PHILIP MORRIS PRODUCTS INC.  
By their Patent Attorneys:  
CALLINAN LAWRIE



Fig. 1A.



Fig. 1B.

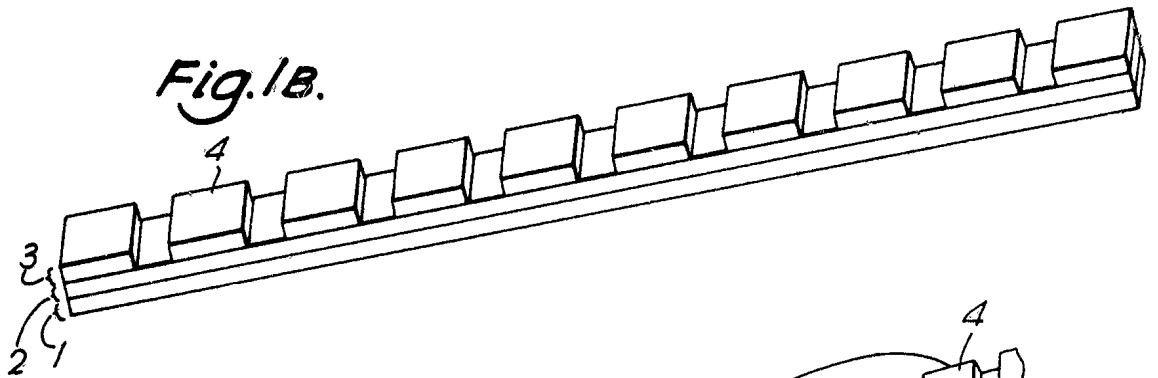

Fig. 1C.

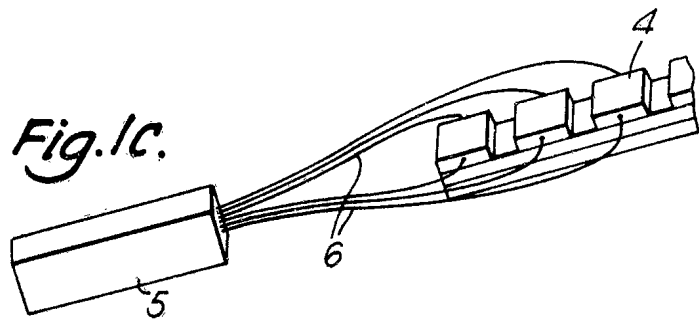

Fig. 2A.

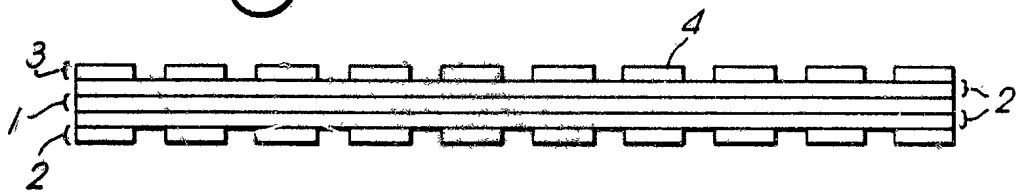

Fig. 2B.

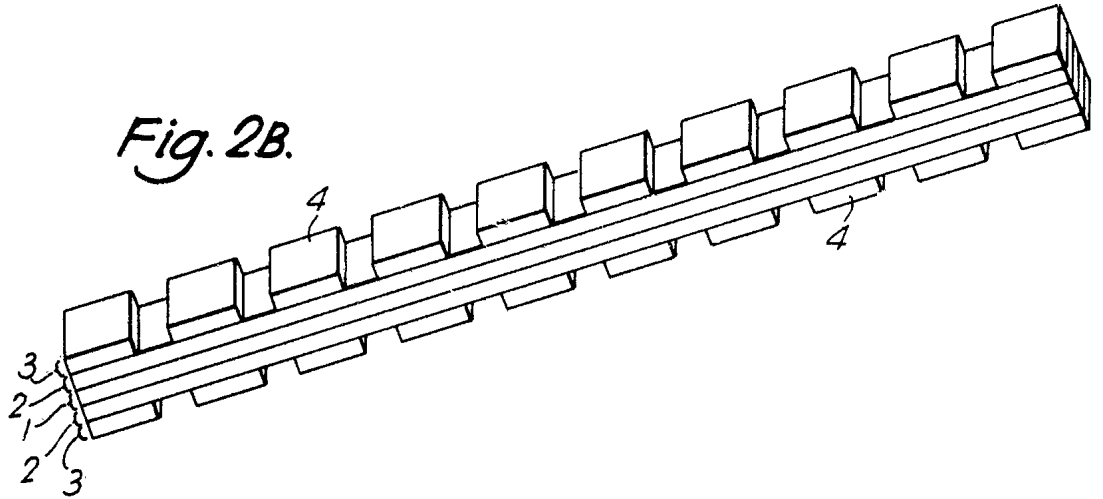

Fig. 3.

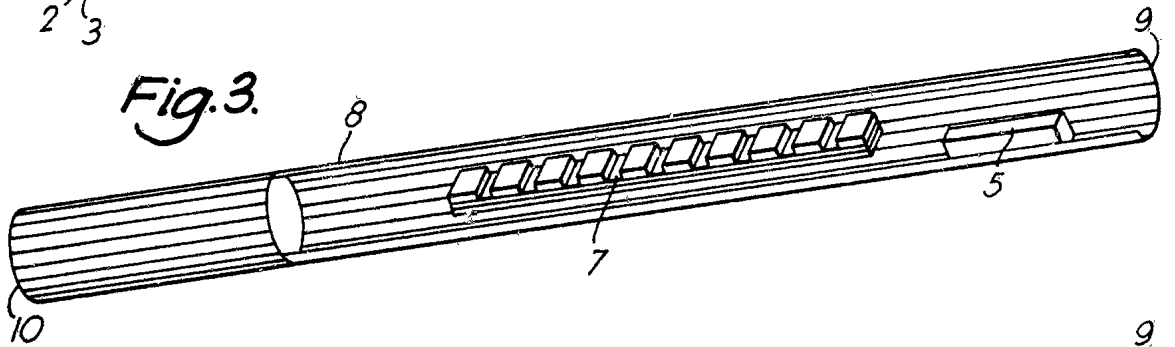

Fig. 4.

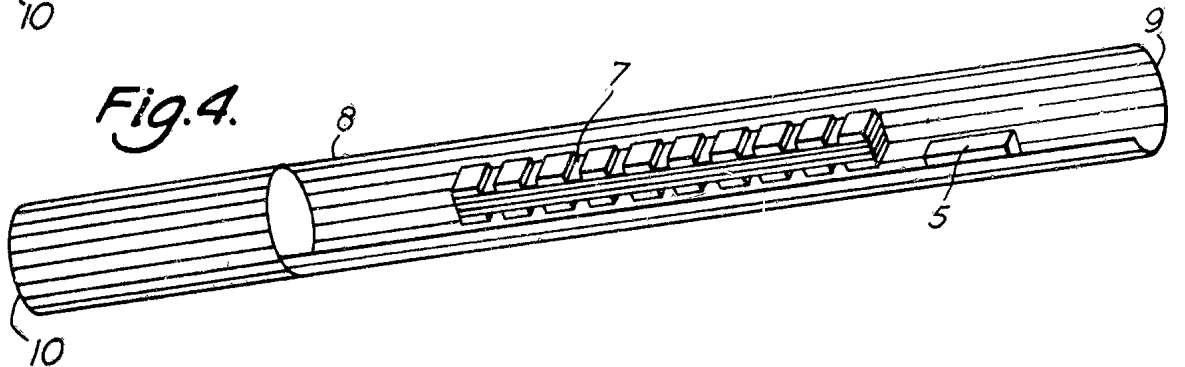
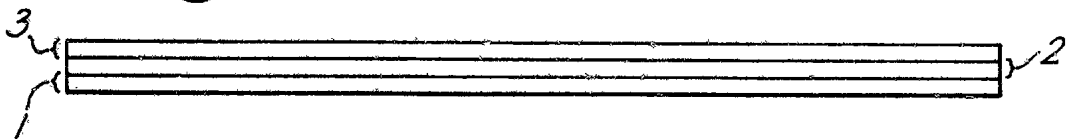
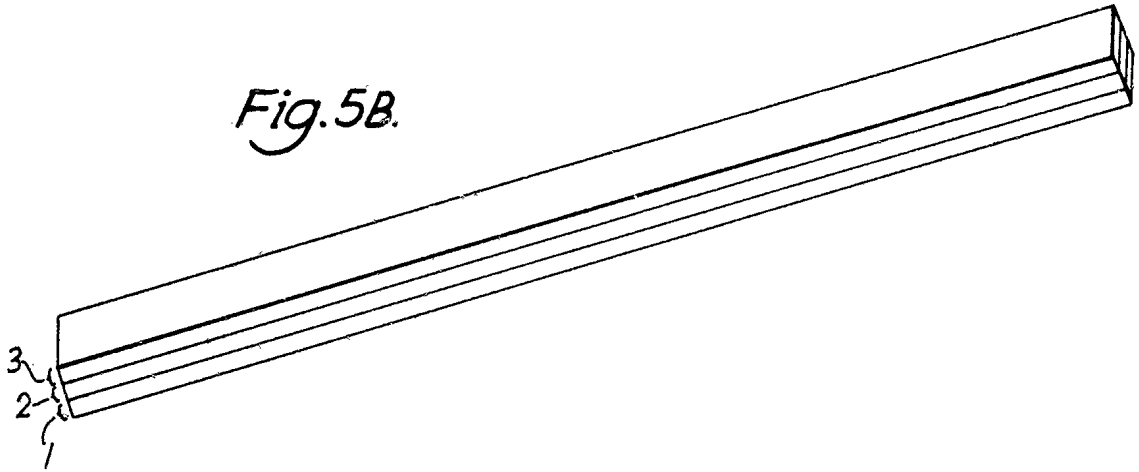

Fig. 5A.



*Fig. 5B.*



*Fig. 6A.*

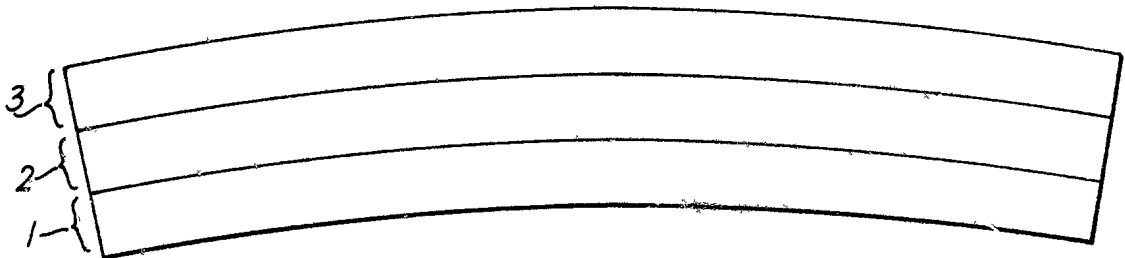

Fig. 6B.

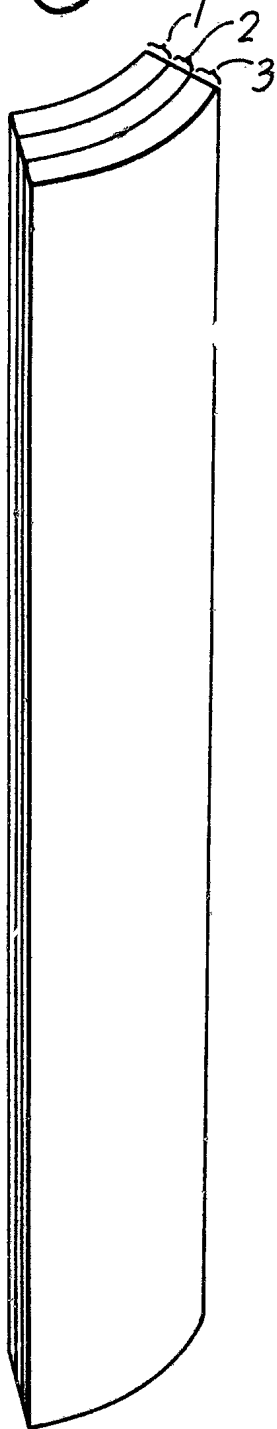

Fig. 7A.

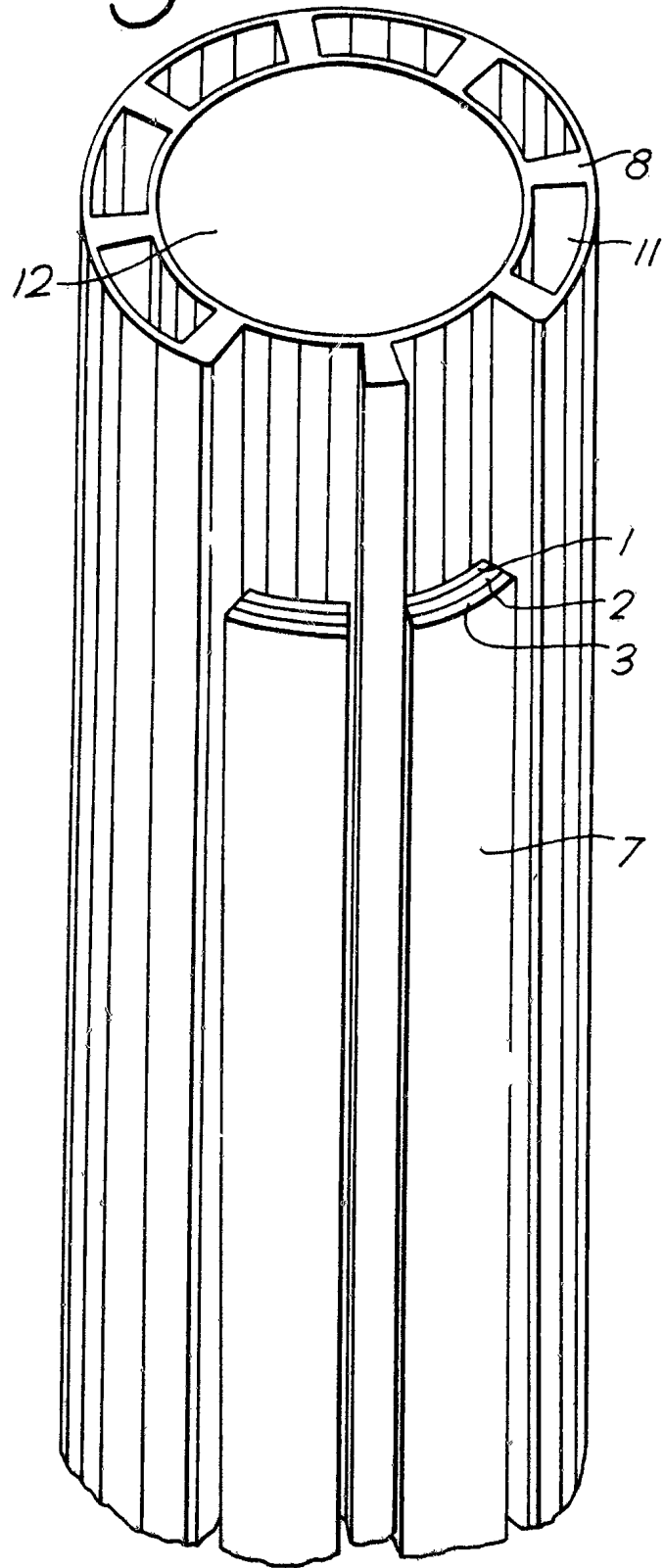

Fig. 7B.

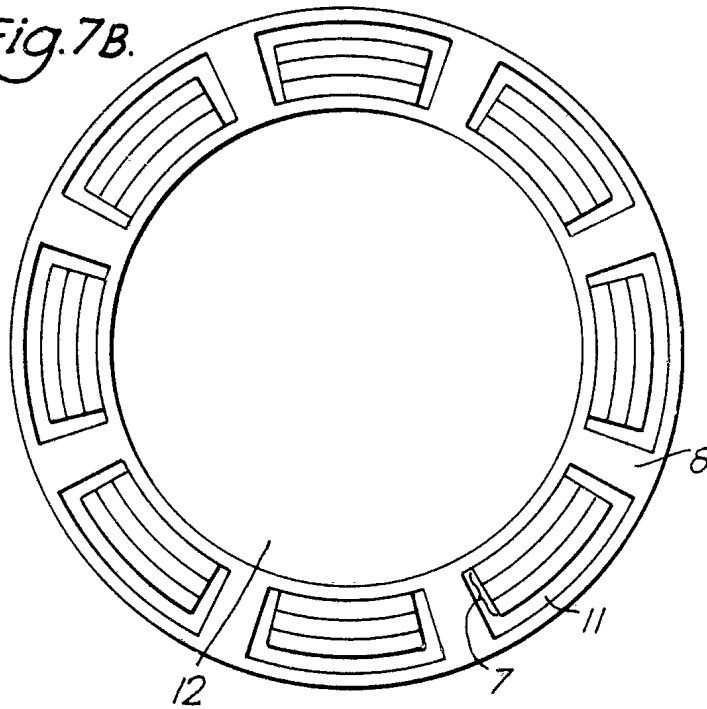

Fig. 8A.

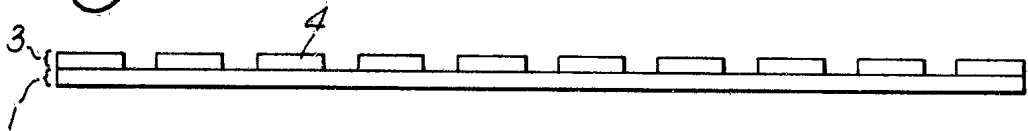

Fig. 8B.

