

C. J. APPLETON.
KNITTING MACHINE.

No. 107,750.

Patented Sept. 27, 1870.

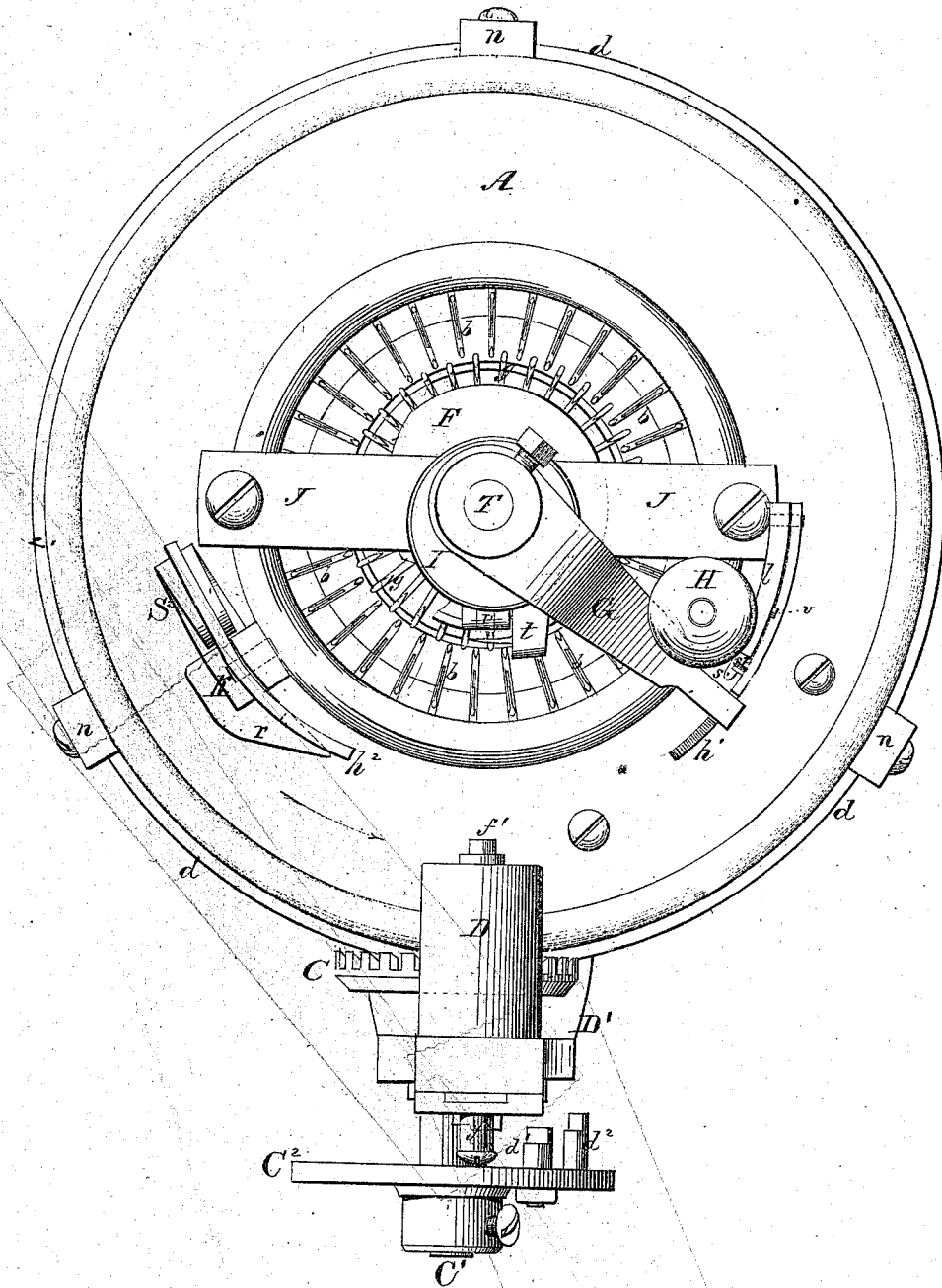

Witnesses.
R. T. Campbell
J. M. Campbell

Inventor
Chas. J. Appleton
By
Mason F. Wood & Son

C. J. APPLETON.
KNITTING MACHINE.

No. 107,750.

Patented Sept. 27, 1870.

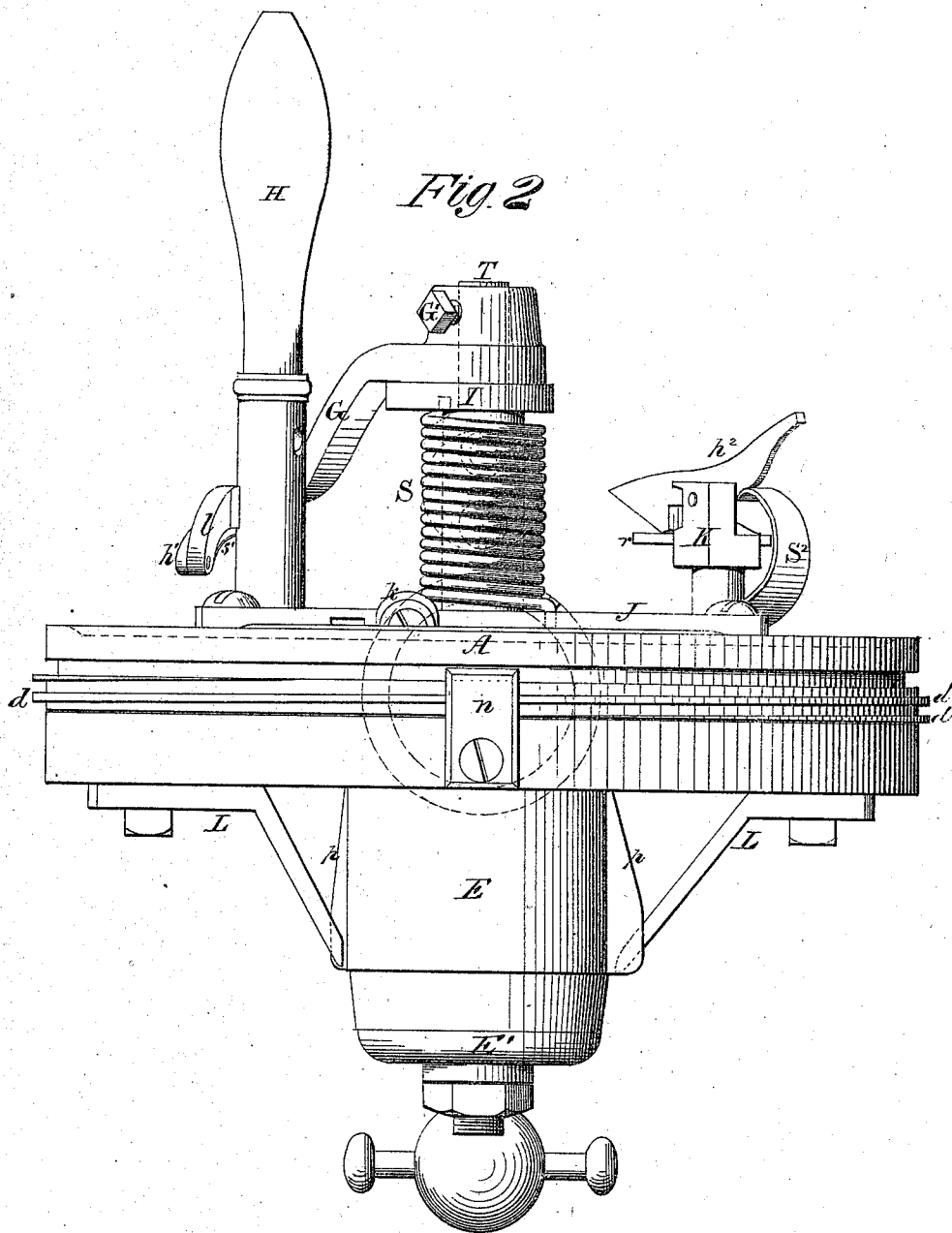

Witnesses.
R. J. Campbell
J. N. Campbell

Inventor
Chas. J. Appleton
Mason, Parrott & Hammon.

C. J. APPLETON.
KNITTING MACHINE.

No. 107,750.

Patented Sept. 27, 1870.

Fig. 1

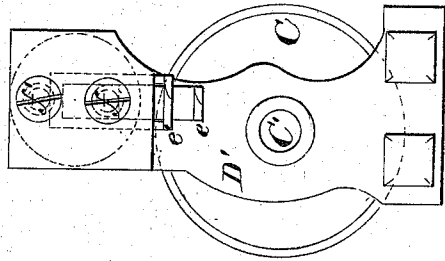

Inventor
Chas. J. Appleton
Atty. Genl.
Messrs. Farnish & Hamer

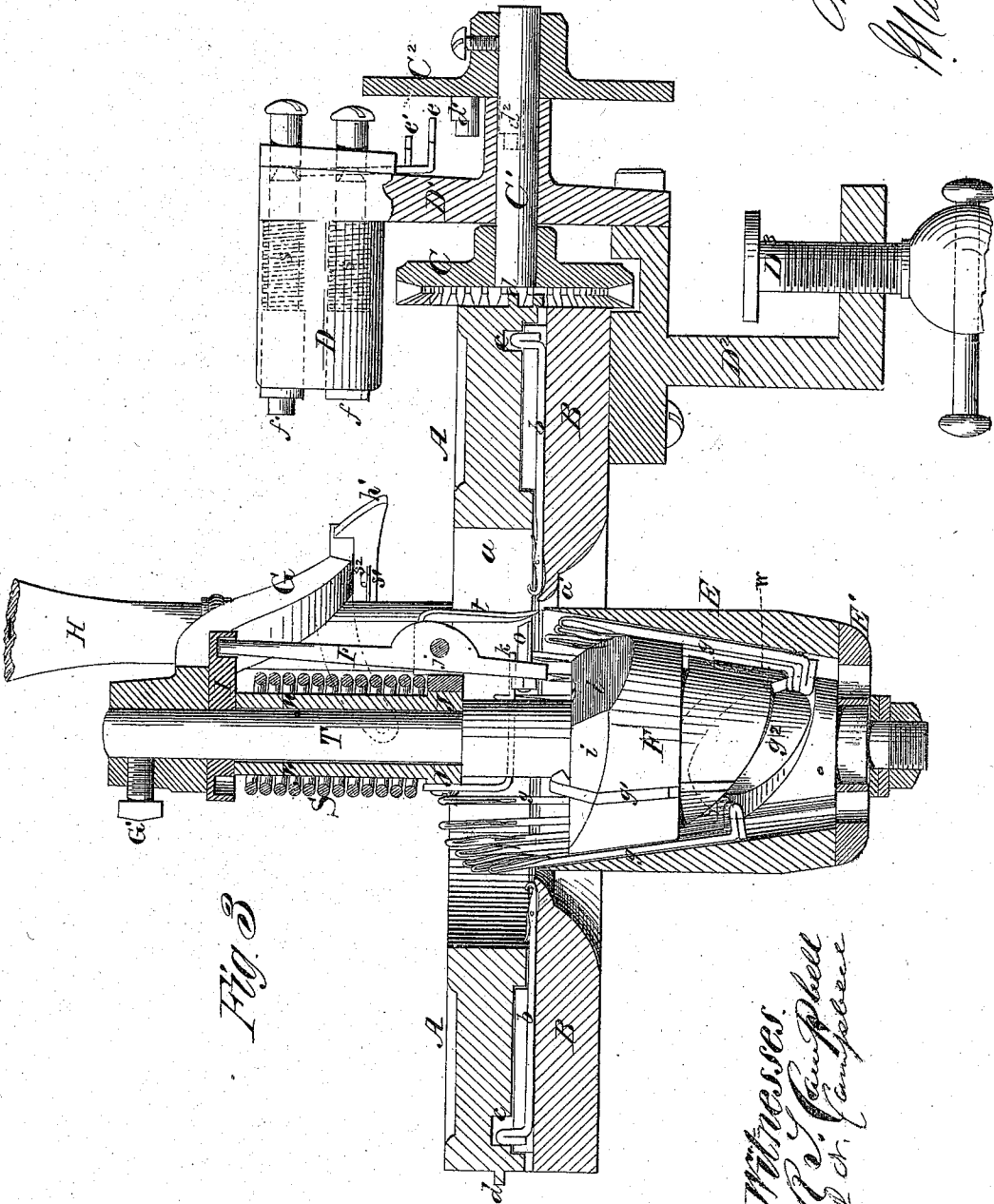

Fig. 3

Witnesses.
R. S. Campbell
J. M. Campbell

C. J. APPLETON.
KNITTING MACHINE.

No. 107,750.

Patented Sept. 27, 1870.

Fig. 5.

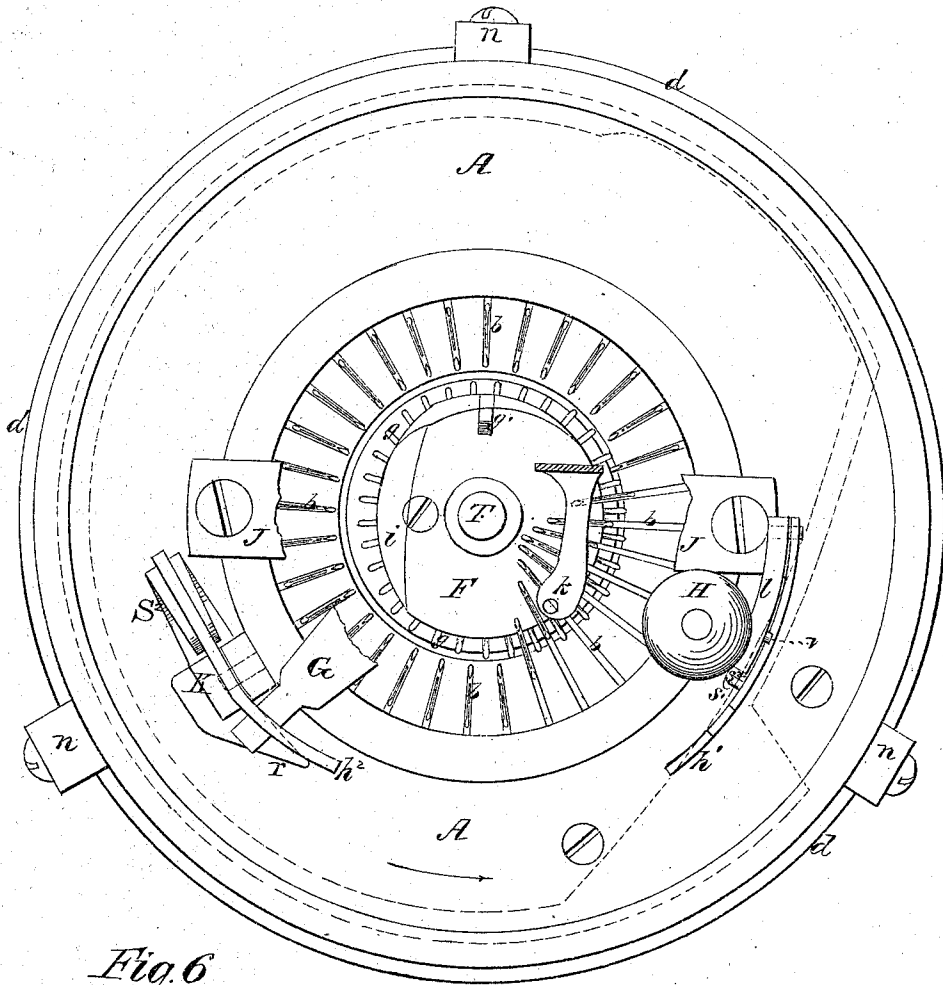
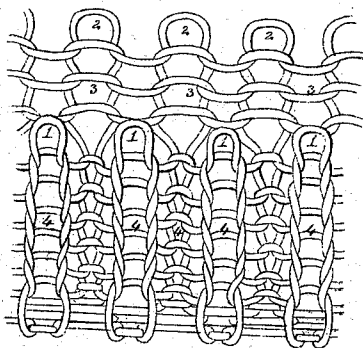

Fig. 6



Inventor
 Charles J. Appleton
 by
 Marv. Lewis & Son

Witnesses.
 R. S. Campbell.
 J. A. Campbell.

United States Patent Office.

CHARLES J. APPLETON, OF COHOES, NEW YORK, ASSIGNOR TO HIMSELF,
EARL L. STIMSON, AND S. EDWARD STIMSON, OF SAME PLACE.

Letters Patent No. 107,750, dated September 27, 1870.

IMPROVEMENT IN KNITTING-MACHINES.

The Schedule referred to in these Letters Patent and making part of the same.

To all whom it may concern :

Be it known that I, CHARLES J. APPLETON, of Cohoes, in the county of Albany, and State of New York, have invented certain new and useful Improvements in Knitting Machinery; and I do hereby declare that the following is a full, clear, and exact description thereof, reference being had to the accompanying drawing making part of this specification, in which—

Figure 1, plate 1, is a top view of the improved machine.

Figure 2, plate 2, is a view of one side of the improved machine.

Figure 3, plate 3, is a section taken diametrically through the machine.

Figure 4, plate 3, is an end elevation of the bearing for the tripping devices and toothed wheel.

Figure 5, plate 4, is a top view of the machine, with portions broken away to expose the two sets of needles and the yarn-guide.

Figure 6, plate 4, is a view of the fabric as it would hang from the machine while knitting plain work, showing the plain loops above and the ribbing below.

Similar letters of reference indicate corresponding parts in the several figures.

This invention relates to improvements on that class of circular knitting machinery which is adapted for working two sets of needles and producing seamless ribbed fabrics.

The objects of my invention are—

First, to make seamless tubular knit fabrics with welted or finished ends, of any desired circumference, on circular knitting machinery.

Second, to make circular or tubular knit fabrics with welts, connectedly or continuously, of any desired length, in such manner that, by cutting the fabric apart at given points, the sections will have welted or finished ends.

The principle of my invention consists in providing for automatically changing from ribbed to plain work and back again to ribbed work, and in retaining the loops last formed on the ribbing needles when these needles are adjusted out of operation, so that when the latter are again brought into operation the loops which were on them will be knit into the next course of ribbed work, thereby binding the plain work and forming a welt, as will be hereinafter explained.

The following description will enable others skilled in the art to understand one practical mode of carrying it into effect.

A and B represent two circular plates having circular passages, *a a'*, centrally through them, in which are exposed the operating ends of the two sets of knitting-needles *b* and *g*, and also the upper ends of the cam-cone F, and its cup E.

The plate A is allowed to rotate freely, which mo-

tion may be given to it by a handle, H, rising perpendicularly from it, or by any other suitable means.

The plate B is stationary, and has secured to it a clamping device, D² D³, by means of which the machine can be fixed to the edge of a table or other established object.

By means of the three fingers *n n n*, which are fastened to the plate B, and constructed with lips that are received in an annular groove made into the circumference of the plate A, this latter plate is confined in place upon the plate B, but allowed to rotate freely.

The upper surface of the plate B is channeled radially to receive and guide the upper set of needles, *b*, which are latch-needles, but may be spring-needles; and the bottom side of the plate A has a groove, *c*, formed into it, of the shape indicated in dotted lines, fig. 5, for receiving the butts of the needles *b*, and giving the required movements to these needles toward and from the center of the machine.

The ribbing-needles *g*, which move up and down between the needles *b*, are arranged in channels formed into the inner side of the cup E, which cup is suspended in the center of the machine, so that its upper circular edge is nearly on a line with the inner edge of the plate B, as shown in fig. 3.

Within the cup E is an inverted cone, F, having an oblique cam-groove, *g'*, in its cone surface for receiving the butts of the needles *g*, and giving vertical motion to these needles.

w is an adjustable section of the cone F, for increasing or diminishing the strokes of the needles *g*; and *g'* is a gate for allowing the removal of these needles from and their insertion into their channels.

The needles *g* are of the barbed kind, and receive up-and-down motions from the oblique groove *g'* by the rotation of the cone F with the plate A.

The cup E, which is applied loosely to the lower end of the shaft T of the cone F, by means of a nut and washers, and a loose plate, E', is prevented from rotating with said cone by means of the downwardly converging arms L L, which are secured to plate B, and which receive against their lower ends lugs or ears, *p p*, on the exterior of the cup.

The shaft T rises vertically through a bridge, J, which is fixed to the plate A, and extended diametrically across the vertical passage through the same, also through the tube J', which rises perpendicularly from said bridge.

Above the tube J' is a circular plate, I, having a groove in its bottom surface, which groove, when the plate I is applied fast to shaft T, is eccentric to the axis of this shaft, and will therefore operate on the upper end of a lever, I', as a cam, when shaft T is turned independently of the plate A, as will be further explained hereinafter.

The object of the cam-plate I is to move the beard-closer O away from the beards of needles *g*, when it is desired to allow loops to remain on these needles during the knitting of plain loops by the needles *b*.

The lever I' is pivoted to ears on one side of the bridge J, at *j*; and to the lower end of this lever the beard-closer O is adjustably attached, so as to close the beards of the needles *g*, when the latter co-operate with needles *b* in producing ribbed work.

Above the cam-plate I, and rigidly secured to the shaft T, is an arm, G, which extends outward and downward, so that its outer end may be received by either one of two catches, *h*¹ *h*², and also be arrested by a dog, *f*, when the latter is released from its catch, *e*, as will be hereinafter explained.

The hooked catch *h*¹ is pivoted to an arm, L, which is secured to the handle H; and this catch is held up against a stud, *r*, on said arm, by a spring, *s*', in position for receiving and holding the end of arm G, as shown in figs. 1 and 3.

The hooked catch *h*² is constructed with a backward extension, beneath which is a spring, S², that presses the hooked nose of the catch *h*² down upon a horizontal rest, *r*, which latter is applied to the post *k*, to which said catch is pivoted.

These two catches *h*¹ *h*² are arranged at such a distance apart relatively to the highest point of the oblique groove *g*², and the yarn-guide *k*, through which yarn is fed to the needles, that when the arm G is held by the catch *h*², as in fig. 5, both sets of needles will operate and produce ribbed work, and when said arm G is held by catch *h*¹ the needles *g* will be thrown out of operation, and needles *b* will produce plain work.

The helical spring S, which is coiled around the tube J', is connected, at one end, to cam-plate I, and at the other end to the bridge J, and is intended to move the arm G over to the catch *h*¹, when this arm is released from the catch *h*², as will be hereinafter explained.

The yarn-guide *k* is arranged over the needles *g* *b* in proper position to distribute yarn to them, and it is secured to the bridge J, and receives yarn from the handle H, through which it is passed from the cap or spool.

The finger *t*, which also depends from the bridge J, is intended to hold the work down below, as the needles *g* rise, and to prevent dropping of the loops, while knitting ribbed work.

A screw-thread or worm, of one or more turns, *d*, is formed around the circumference of the plate A, and engages with the teeth of the spur-wheel C.

This wheel C is keyed on a horizontal shaft, C¹, which passes through and has its bearings in a standard, D¹, rising from the clamp-jaw D², as shown in fig. 3.

On the outer end of shaft C¹ is keyed a disk, C², having two tripping-pins, *d*¹ *d*², fixed to its inner face, at proper distances apart, one of which pins, *d*², is intended to act on a sliding catch, *e*¹, while the other is intended to act on a similar catch, *e*, at every revolution of said shaft.

At the upper end of the standard D¹, and extending inward or toward the center of the machine, is a head, D, which overhangs the plate A and receives through it two spring-dogs, *f* *f*¹, arranged one over the other, as shown in fig. 3.

The dogs are both acted on by springs *s*, inclosed within the head D; one of which springs will move the dog *f*¹ inwardly, when released from its catch *e*¹ far enough to operate on the tail of catch *h*², and release from this catch the arm G, thus allowing spring S to move this arm to the catch *h*¹. The other spring S will operate on the dog *f* when it is released from its catch *e*, and throw out this dog far enough to arrest

the arm G, and deliver its end to the catch *h*², as the plate A is moved around. Thus it will be seen that the adjustments are automatic.

The operation of the machine is as follows:

The machine is secured to a bench or table, and the operator sits in a convenient position to turn the plate A, by grasping the handle H. The movable arm G is held in position by the catch *h*², as shown in fig. 5, and the plate A, with its attachments, is turned from left to right, as indicated by the arrows in figs. 1 and 5, thus knitting one and one ribbed work, as shown at 4 4, fig. 6.

With each revolution of the plate A, the worm *d* moves the spur-wheel C, and when a sufficient number of courses of ribbed work have been made, (regulated by the number of teeth on wheel C,) the outer pin *d*² on plate C² trips the catch *e*¹, and releases the dog *f*, which is pushed by its spring *s* toward the center of the machine, and by its depressing the tail of catch *h*², the arm G is released, and is thrown around, by spring S, to the catch *h*¹. The arm G, being attached to the shaft T of the cone F, (in the oblique groove in which the butts of the needles *g* work,) the cone F is carried around far enough to take the ribbing-needles out of the way of the yarn, as it is fed through the guide *k*, and yet these needles retain their loops, 1 1, fig. 6, for, by the action of the eccentric or cam-plate I and lever I', the presser *o* (which, in making ribbed work, acts to close the beards of the needles *g*,) is moved inwardly away from the needles *g*, and the loops 1 1, fig. 6, last formed on them, are retained.

The horizontal needles *b* continue to work and produce plain courses, 2 3, of knitting, for any desired number of revolutions. In the machine represented in the drawing, three courses of plain knitting are formed at every change.

The tail of the catch *h*² returns the dog *f*¹ to its original position in the same revolution during which this dog was released, and the latter is again held by its catch *e*¹.

When the given number of plain courses 2 3 have been made, the inner pin *d* on the plate C² pushes down the catch *e*, and the dog *f* is released and thrown toward the center of the machine far enough to engage arm G. During the succeeding revolution the dog *f* depresses the catch *h*¹ and arrests the arm G, until the catch *h*² is moved around and takes this arm, when the beveled edge of rest *r* pushes back the dog *f* to its original position, where it is retained by its spring catch *e*.

The several parts of the machine are now in their original positions, and produce ribbed work, 4 4, fig. 6; the first course of loops taken up are thrown over the first row of plain loops, to produce the welt.

It will be seen, from the above description, that the annular welts are produced by two changes, to wit: From ribbing to plain knitting, and back again from plain to ribbed knitting. When a sufficient length of ribbing is made, the ribbing-needles *g* are drawn down from between the horizontal needles *b*, in such manner that, when the former rise, they will be beyond the point where the yarn is fed to the horizontal needles *b*, consequently, while the needles *g* retain the loops last formed on them, they do not form other loops.

After the required number of loops have been formed by the horizontal needles acting alone, the ribbing-needles are again adjusted into operation, to produce ribbed work, when the first course knit will receive into it the binding-loops, which were, for a time, kept out of the way. The retained loops, overlapping the plain loops, will round out the plain work, and produce a thickened place or welt. This operation is continued indefinitely.

In order to separate the cuffs or welted sections,

and leave each piece with a finished end, the fabric must be cut across through that course of ribbed loops, which was the last course completed before the ribbing-needles were drawn out of the way, for the purpose of knitting plain work. The work cut in this manner will not ravel, for the reason that ribbed work made on two sets of needles will ravel only from the last loop made toward its predecessors, and will not ravel from a former loop toward the last made.

The making of welts on flat or straight knitting-frames has long been performed, and is effected by depressing the straight bar which carries the ribbing-needles, but I believe that I am the first to have ever adapted a knitting-machine to produce welts on seamless or tubular work.

I do not, therefore, confine myself to the precise form and arrangement of devices herein set forth, for effecting said object, as other devices equivalent thereto may be employed; nor do I claim as my invention the combination, in a circular knitting-machine, of two sets of needles operating together to produce tubular work.

Having described one practical mode of carrying my invention into effect,

What I claim as new, and desire to secure by Letters Patent, is—

1. In a circular knitting-machine, having two sets of needles, mechanism substantially such as described,

which will admit of automatically adjusting one set of needles out of operation at pleasure, and producing plain work on the other set.

2. A circular knitting-machine, having two sets of needles or loop-formers, and provided with contrivances substantially such as described, which will automatically effect the changes from ribbed knitting to plain knitting, and back again to ribbed knitting.

3. The automatically adjustable cam-cone F, in combination with mechanism substantially such as described, for producing welts on tubular-knit fabric.

4. The combination of an adjustable beard-presser *o*, with the adjustable cam-cone F, said parts working together, substantially as described.

5. The arm G, applied to the shaft of the adjustable cam-cone F, and acted upon by a spring, S, in combination with devices substantially as described, which are controlled by the movements of the plate A, and adapted to operate said arm and cam, as set forth.

6. The arrangement of finger *t* in the relation shown to the rib-needles *g*, the yarn-guide *k*, and presser *o*, for the purpose stated.

CHARLES JAMES APPLETON.

Witnesses:

E. W. FULLER,
JAMES CRAMER.